

**OPERATOR'S, UNIT, DIRECT SUPPORT AND
GENERAL SUPPORT MAINTENANCE MANUAL
(INCLUDING REPAIR PARTS AND SPECIAL
TOOLS LIST) FOR**

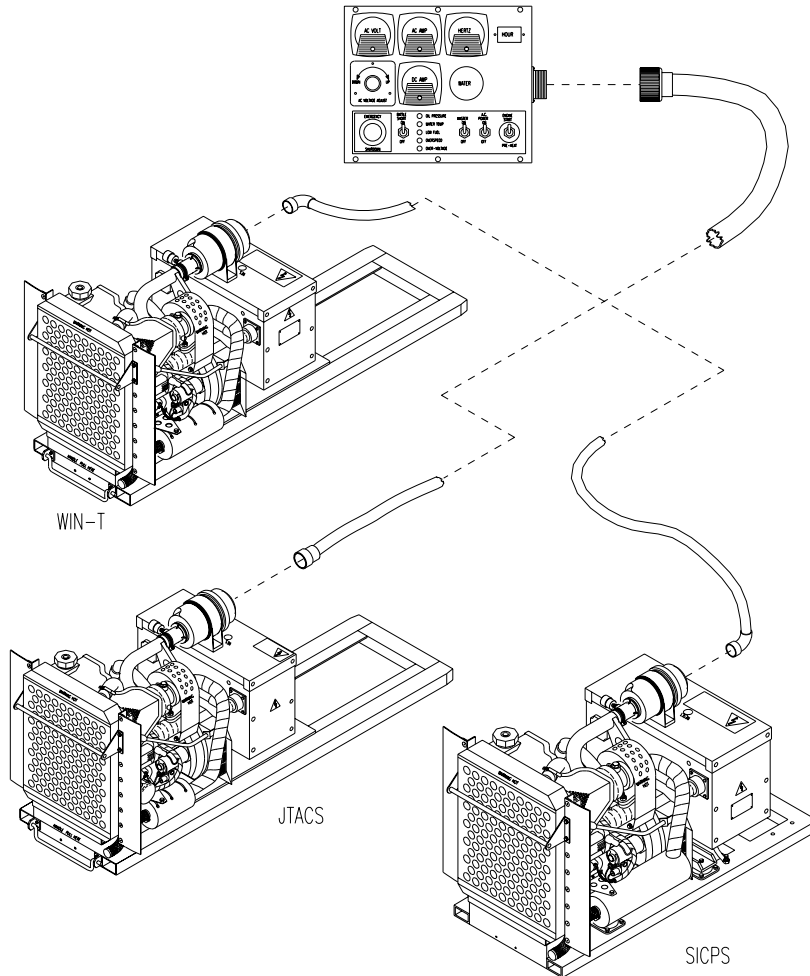

**OPERATING INSTRUCTIONS
PAGE 2-1**

**OPERATOR MAINTENANCE
PAGE 3-1**

**OPERATOR TROUBLE-
SHOOTING PAGE 3-1**

**UNIT MAINTENANCE
PAGE 4-1**

**UNIT TROUBLESHOOTING
PAGE 4-10**

**DIRECT SUPPORT
MAINTENANCE PAGE 5-1**

**DIRECT SUPPORT TROUBLE
SHOOTING PAGE 5-2**

**GENERAL SUPPORT
MAINTENANCE PAGE 6-1**

**AUXILIARY POWER UNIT
10 KW, 120/240 VAC, 60 HZ
MODEL NO. MEP-903A (SICPS)
NSN 6115-01-431-3062,
MODEL NO. MEP-903B (JTACS)
NSN 6115-01-431-3063,
MODEL NO. MEP-903C (WIN-T)
NSN 6115-01-458-5329
(EIC: N/A)**

DISTRIBUTION STATEMENT A: Approved for public release; distribution is unlimited.

CHANGE

HEADQUARTERS
DEPARTMENT OF THE ARMY
WASHINGTON, D.C., 23 September 2004

No. 1

**OPERATOR'S, UNIT, DIRECT SUPPORT AND
GENERAL SUPPPORT MAINTENANCE MANUAL
(INCLUDING REPAIR PARTS AND SPECIAL
TOOLS LIST) FOR**

**AUXILIARY POWER UNIT
10 KW, 120/240 VAC,60HZ
MODEL NO. MEP-903A (SICPS)
NSN 6115-01-431-3062,
MODEL NO. MEP-903B (JTACS)
NSN 6115-01-431-3063,
MODEL NO. MEP-903C (WIN-T)
NSN 6115-01-458-5329,
(EIC: N/A)**

TM 9-6115-670-14&P, 01 OCTOBER 2002, is changed as follows:

1. Title is not changed.

2. Remove and insert pages as indicated below. New or changed text material is indicated by the words Change 1 in the margin. An illustration change is indicated by a miniature pointing hand.

Remove pages	Insert Pages
A/B	A/B
3-19 thru 3-20	3-19 thru 3-20
4-75 thru 4-76	4-75 thru 4-76
4-93 thru 4-94	4-93 thru 4-94
4-123 thru 4-124	4-123 thru 4-124
4-125 thru 4-126	4-125 thru 4-126
4-131 thru 4-132	4-131 thru 4-132
4-135 thru 4-4-136	4-135 thru 4-4-136
5-49 thru 5-50	5-49 thru 5-50
5-51 thru 5-52	5-51 thru 5-52
5-53 thru 5-54	5-53 thru 5-54
5-71 thru 5-72	5-71 thru 5-72
5-75 thru 5-76	5-75 thru 5-76
5-81 thru 5-82	5-81 thru 5-82
5-85 thru 5-86	5-85 thru 5-86
5-103 thru 5-104	5-103 thru 5-104
Appendix C, Section I thru III	Appendix C, Section I thru III
----	Appendix C, Section IV, C-I-57 thru C-i-77

3. Retain this sheet in front of manual for reference purpose.

By Order of the Secretary of the Army:

Peter J. Schoomaker
General, United States Army
Chief of Staff

Official:

JOEL B. HUDSON
*Administrative Assistant to the
Secretary of the Army*

DISTRIBUTION: To be distributed in accordance with the initial distribution number (IDN) 256751 requirements for TM 9-6115-670-14&P



5

SAFETY STEPS TO FOLLOW IF SOMEONE IS THE VICTIM OF ELECTRICAL SHOCK

1

DO NOT TRY TO PULL OR GRAB THE INDIVIDUAL

2

IF POSSIBLE, TURN OFF THE ELECTRICAL POWER

3

IF YOU CANNOT TURN OFF THE ELECTRICAL POWER, PULL, PUSH, OR LIFT THE PERSON TO SAFETY USING A DRY WOODEN POLE OR A DRY ROPE OR SOME OTHER INSULATING MATERIAL

4

SEND FOR HELP AS SOON AS POSSIBLE

5

AFTER THE INJURED PERSON IS FREE OF CONTACT WITH THE SOURCE OF ELECTRICAL SHOCK, MOVE THE PERSON A SHORT DISTANCE AWAY AND IMMEDIATELY START ARTIFICIAL RESUSCITATION

Hazard Awareness Notice

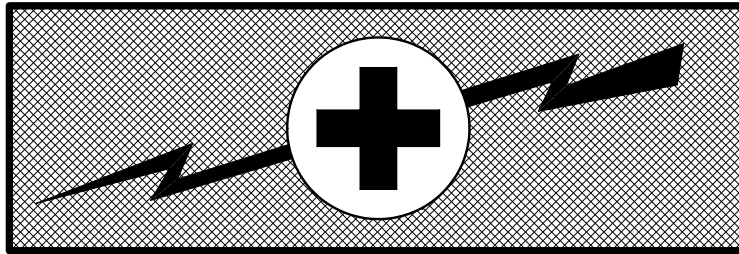

WARNING SUMMARY

HIGH VOLTAGE is used in the operation of this equipment.

DEATH ON CONTACT may result if personnel fail to observe safety precautions.

Ground the equipment. Before connecting primary power, connect a ground strap from the ground lug on the frame assembly to earth ground. Do not remove this ground strap until the primary power has been disconnected.

Avoid the power input and all live circuits. Be careful not to contact the input 120/240 VAC connections when installing or servicing the equipment. Avoid all open terminals and live circuits. Beware of dangerous potentials retained in capacitors even after power is removed.

Do not service alone. Never work on the equipment unless there is another person nearby who is familiar with the operation and the hazards of the equipment and who can administer first aid.

Use one hand. Where possible, use only one hand to service the equipment. Keep the other hand away to reduce the hazard of current flowing through the vital organs of the body.

HEAVY EQUIPMENT - Much of this equipment weighs over 35 pounds and can cause serious injury if lifted or carried alone. Do not attempt to lift, carry, or move the equipment by yourself - get help. The Auxiliary Power Unit (APU) weighs 495 pounds. Use mechanical lift only to move equipment. Do not attempt to lift, carry, or move equipment without mechanical lift.

WARNING

KEEP AWAY FROM LIVE CIRCUITS - Operating personnel must observe every safety regulation at all times. Do not replace components or make adjustments inside the equipment with the batteries connected. Dangerous potentials may exist under certain conditions when the generator set MASTER switch is in the off position because of charges retained by capacitors. Avoid casualties by always shutting off the generator set, disconnecting batteries, and discharging and grounding a circuit before touching it.

WARNING

DO NOT SERVICE OR ADJUST ALONE - Never reach into or enter generator enclosure or shelter tunnel to service or adjust the equipment.

WARNING

Trichlorotrifluoroethane, trichloroethane and similar solvents will no longer be used for ordinary cleaning of equipment. These substances threaten public health and the environment by destroying ozone in the Earth's upper atmosphere. Suitable nonhazardous cleaning materials will be used instead, such as a clean cloth, water and mild detergent.

WARNING

DANGEROUS GASES - Exhaust discharge contains noxious and deadly fumes. DO NOT operate this equipment in enclosed areas until the exhaust discharge is properly vented to the outside. DO NOT SMOKE or use an open flame in the vicinity while refueling is taking place.

WARNING

CARBON MONOXIDE - Carbon monoxide is without color or smell, but can kill you. Breathing air with carbon monoxide produces symptoms of headache, dizziness, loss of muscular control, a sleepy feeling, and coma. Brain damage or death can result from heavy exposure. Carbon monoxide occurs in the exhaust fumes of fuel-burning heaters and internal combustion engines. Carbon monoxide can become dangerously concentrated under conditions of no air movement. Precautions must be followed to ensure crew safety when the heater, main, or auxiliary engine of any vehicle is operated for any purpose.

- DO NOT operate heater or engine in a closed area unless the area has a lot of moving air.
- DO NOT idle engine for long periods without ventilator blower operating.
- Be alert at all times during generator operation for exhaust odors and exposure symptoms. If either is present, immediately ventilate personnel compartments. If symptoms persist, remove affected crew to fresh air, keep warm, do not permit physical exercise. If necessary, give artificial respiration.

FOR ARTIFICIAL RESPIRATION, REFER TO FM 21-11.

- Be aware: the field protective mask for chemical-biological-radiological (CBR) protection will not protect you from carbon monoxide poisoning.

THE BEST DEFENSE AGAINST CARBON MONOXIDE POISONING IS GOOD VENTILATION.

WARNING

LIQUIDS UNDER PRESSURE - Operation of this equipment generates liquids under pressure. DO NOT expose any part of the body to a high pressure leak in the fuel or cooling system of this Primary Power Unit.

WARNING

Disable all rotating equipment before performing maintenance. Rotating equipment is used in the operation of this equipment. When performing maintenance, know the location and status (operating/off) of the rotating equipment

WARNING

Avoid power cables interconnecting equipment to prevent tripping injuries and possible damage to equipment connectors.

WARNING

Remove all jewelry before beginning work on the equipment.

- Jewelry can conduct electrical current. Accidental contact can result in electrocution or severe burns.
- Jewelry can be caught in mechanically moving parts, in tight spaces, or on protruding parts, resulting in severe injury

WARNING

If a circuit breaker does not stay in ON position when closed, do not attempt to close it repeatedly, which could create an overload situation hazardous to personnel and equipment. Instead, investigate cause of problem. Correct situation before attempting to close the breaker again.

WARNING

Do not stand in the operating area of cranes or forklifts. Do not stand under cranes or in the openings of forks on forklifts. Failure to heed this warning could result in severe injuries or death.

SPECIFIC WARNINGS

WARNING

Compressed air shall not be used for cleaning purposes except where reduced to less than 29 pounds per square inch gauge (psig) (199.94 kPa), and then only with effective chip guarding and personnel protective equipment. Compressed air is dangerous and can cause serious bodily harm if protective means or methods are not observed to prevent chip or particle (of whatever size) from being blown into the eyes or unprotected skin of the operator or other personnel.

WARNING

Dry cleaning solvent used to clean parts is potentially dangerous to personnel and property. Clean parts in a well-ventilated area. Avoid inhalation of solvent fumes. Wear goggles and rubber gloves to protect eyes and skin. Wash exposed skin thoroughly. Do not smoke or use near open flame or excessive heat. Failure to observe this warning can cause severe injury to personnel or DEATH.

WARNING

Never attempt to start the APU if it is not properly grounded. Refer to the system technical manual for proper grounding procedures. Failure to observe this warning may result in serious injury or DEATH by electrocution.

WARNING

Ensure that APU DC power supply is disconnected. Failure to observe this warning could result in severe injury or DEATH to personnel.

WARNING

Ensure that the APU is turned off and completely de-energized before opening generator housing. Failure to observe this warning could result in severe injury or DEATH to personnel.

WARNING

DC voltages are present at generator set components, even with generator set shutdown. Avoid grounding self when touching any electrical components. Failure to observe this warning can result in personal injury or DEATH by electrocution.

WARNING

Batteries contain explosive gas. ALWAYS make jumper connections at battery FIRST, then at starter. Failure to heed this warning could cause severe injury or DEATH.

WARNING

Wear approved hearing protection while operating the 10kW APU. Failure to heed this warning can cause severe injury to personnel.

WARNING

Never place ends of electrical cables or connectors on the ground. Dirt and moisture can lead to a faulty electrical connection and create a shock or fire hazard.

WARNING

Ensure that NO IGNITION SOURCE is within 50 feet of the APU. The fuel in this APU is highly flammable. Do not smoke. Do not splash fuel on hot components. Failure to heed this warning could result in serious injuries to personnel or DEATH.

WARNING

Avoid fuel contact with skin. Wear protective gloves, goggles, apron and mask. Failure to heed this warning could result in serious injuries to personnel or DEATH.

WARNING

Hot coolant is under pressure. Do not remove radiator cap when engine is hot. Allow engine to cool completely before removing radiator cap. Once cooling has occurred, loosen cap slightly to relieve any excess pressure before removing the cap completely. Failure to observe this warning could result in burns or injury to personnel.

WARNING

Always point fuel spray away from direction of personnel. Contact with the fuel spray could cause blood poisoning and cell damage. Always aim spray into a suitable container. Failure to observe this warning could result in serious injuries to personnel or DEATH.

WARNING

CARC paint is a health hazard. Wear protective eyewear, mask and gloves when sanding CARC painted surfaces. Failure to comply can cause personal injury.

WARNING

Do not operate APU with radiator hose or fan guard removed. Failure to heed this warning could result in injury to personnel or damage to equipment.

WARNING

Allow engine to cool completely before removing temperature sender. Failure to observe this warning could result in severe injury to personnel.

WARNING

A heavy lifting device and two personnel are required to lift the diesel engine on and off the frame. The diesel engine weighs 139 pounds (62 kg). A lifting device with lifting capacity of 500 pounds (226.8 kg) is required to lift the diesel engine. DO NOT use a lifting device with lifting capacity of less than 500 pounds (226.8 kg). Failure to observe this warning could result in severe injury or DEATH to personnel.

WARNING

A Lifting device capable of lifting 600 pounds (271.8 KG) is required to lift APU. Failure to observe this warning could result in severe injury or DEATH to personnel.

WARNINGS

- DO NOT stand or sit on the 10kW generator as it is being hoisted, lowered, or transported.
- DO NOT lift the 10kW generator over personnel.
- When using lift ring, ensure that a closed ring with safety latch is used. NO OPEN HOOKS are to be used when lifting 10kW generator.
- Lift ring must have a swivel attached to prevent equipment from swinging.
- Hard hats must be worn when 10kW generator is removed by overhead lift ring.

Failure to observe these warnings could result in severe injury to personnel or DEATH.

WARNING

Do not attempt to work on hot engine. Failure to heed this warning could result in injury to personnel or damage to equipment.

WARNING

Bolts securing engine to engine mount support the weight of the engine. Do not remove screws. Failure to heed this warning could result in injury to personnel or damage to equipment.

WARNING

Do not use oil pan located at bottom of generator to block generator set. Failure to heed this warning could result in severe damage to equipment or injury to personnel.

WARNING

Wear protective gloves when using red lead. Dispose of red lead in accordance with local ordinances.

LIST OF EFFECTIVE PAGES

INSERT LATEST CHANGED PAGES, DESTROY SUPERSEDED PAGES

Note: The portion of the text effected by the changes is indicated by a vertical line in the outer margins of the page. Changes to illustrations are indicated by miniature pointing hands. Changes to diagrams are indicated by shaded areas.

Dates of issue for original and changed pages are:

Original 0 1 August 2002

TOTAL NUMBER OF PAGES IN THIS PUBLICATION IS 773, CONSISTING OF THE FOLLOWING:

Page No.	*Change No.	Page No.	*Change No.	Page No.	*Change No.
Title	0	6-1 thru 6-92	0	Fig C-9 (2 sheets).....	0
Title Blank	0	A-1	0	C-9-1 thru C-9-2	1
a thru h	0	A-2 Blank.....	0	Fig C-10 (1 sheet).....	1
A thru B	1	B-1 thru B-10.....	0	C-10-1	1
I thru viii	0	C-1 - C-6.....	0	Fig C-11 (1 sheet).....	0
Ix Blank.....	0	Fig C-1 (1 sheet).....	0	C-11-1 thru C-11-2.....	1
1-0 thru 1-23	0	C-1-1	1	Fig C-12 (1 sheet).....	0
1-24 Blank	0	Fig C-2 (8 sheets).....	1	C-12-1 thru C-12-2	1
2-1 thru 2-15	0	C-2-1 thru C-2-18.....	1	Fig C-13 (1 sheet).....	0
2-16 Blank	0	Fig C-3 (1 sheet).....	0	C-13-1	1
3-1 thru 3-21	1	C-3-1	1	Fig C-14 (1 sheet).....	0
3-22 Blank	0	Fig C-4 (2 sheets).....	0	C-14-1	1
4-1 thru 4-86.....	1	C-4-1 thru C-4-2	1	Fig C-15 (1 sheet).....	0
4-86.1	0	Fig C-5 (1 sheet).....	0	C-15-1	1
4-86.2 Blank	0	C-5-1	1	Fig C-16 (1 sheet).....	0
4-87 thru 4-144.....	1	Fig C-6 (1 sheet).....	0	C-16-1	1
4-144.1 thru 4-144.2.....	0	C-6-1	1	Fig C-17 (1 sheet).....	0
4-145 thru 4-163	0	Fig C-7 (1 sheet).....	0	C-17-1	1
4-164 Blank	0	C-7-1	1	Fig C-18 (1 sheet).....	0
5-1 thru 5-135	1	Fig C-8 (8 sheets).....	0	C-18-1	1
5-136 Blank	0	C-8-1 thru C-8-10.....	1	Fig C-19 (1 sheet).....	1

* Zero in this column indicates an original page.

LIST OF EFFECTIVE PAGES

INSERT LATEST CHANGED PAGES, DESTROY SUPERSEDED PAGES

Note: The portion of the text effected by the changes is indicated by a vertical line in the outer margins of the page. Changes to illustrations are indicated by miniature pointing hands. Changes to diagrams are indicated by shaded areas.

Dates of issue for original and changed pages are:

Original 0 1 August 2002

TOTAL NUMBER OF PAGES IN THIS PUBLICATION IS 752, CONSISTING OF THE FOLLOWING:

Page No.	*Change No.	Page No.	*Change No.	Page No.	*Change No.
C-19-1	1	C-29-1	1		
Fig C-20 (2 sheets)	0	C-1-1 thru C-1-77	1		
C-20-1	1	D-1 thru D-4	0		
Fig C-21 (3 sheets)	1	E-1 thru E-2	0		
C-21-1 thru C-21-2.....	1	F-1 thru F-3.....	0		
Fig C-22 (2 sheets)	0	F-4 Blank	0		
C-22-1	1	G-1 thru G-2	0		
Fig C-23 (1 sheets)	0	H-1 thru H-11	0		
C-23-1	1	H-12 Blank	0		
Fig C-24 (1 sheets)	0	I-1 thru I-2.....	0		
C-24-1 thru C-24-2.....	1	J-1 thru J-3	0		
Fig C-25 (1 sheets)	0	J-4 Blank.....	0		
C-25-1	1	Index-1 thru Index-3.....	0		
Fig C-26 (1 sheets)	0	Index-4 Blank	0		
C-26-1	1	FO-1	0		
Fig C-27 (3 sheets)	0	FO-2	0		
C-27-1 thru C-27-6.....	1	FO-3	0		
Fig C-28 (2 sheets)	1	FO-4	0		
C-28-1	1	FO-5	0		
Bulk-1	1	FO-6.....	0		
Fig C-29 (6 sheets)	0	FO-7	0		

* Zero in this column indicates an original page.

Operator's, Unit, Direct Support and General Support Maintenance Manual
(Including Repair Parts and Special Tools List)

for
AUXILIARY POWER UNIT 10KW, 120/240 VAC, 60 HZ
MODEL NO. MEP-903A (SICPS) NSN 6115-01-431-3062
MODEL NO. MEP-903B (JTACS) NSN 6115-01-431-3063
MODEL NO. MEP-903C (WIN-T) NSN 6115-01-458-5329
(EIC: N/A)

REPORTING ERRORS AND RECOMMENDING IMPROVEMENTS

You can help improve this manual. If you find any mistakes, or if you know of a way to improve the procedures, please let us know. Mail your letter, DA Form 2028 (Recommended Changes to Publications and Blank Forms), or DA Form 2028-2 located in the back of this manual directly to: Commander, US Army Communications-Electronics Command, ATTN: AMSEL-LC-LEO-D-CS-CFO, Fort Monmouth, NJ 07703-5006. Or fax it to 732-532-3421 (DSN 992). You may also submit your recommended changes by e-mail to AMSEL-LC-LEO-PUB-CHG@mail1.monmouth.army.mil. In any case, a reply will be furnished directly to you.

TABLE OF CONTENTS

	Page
HOW TO USE THIS MANUAL.....	viii
CHAPTER 1 INTRODUCTION.....	1-1
Section I General Information.....	1-1
II Equipment Description	1-4
III Principles of Operation	1-15
CHAPTER 2 OPERATING INSTRUCTIONS	2-1
Section I Description and Use of Operator Controls and Indicators	2-1
II Operator Preventive Maintenance Checks and Services (PMCS)	2-4
III Operation Under Usual Conditions.....	2-12
IV Operation Under Unusual Conditions	2-14
CHAPTER 3 OPERATOR MAINTENANCE INSTRUCTIONS	3-1
Section I Lubrication Instructions	3-1
II Operator Troubleshooting	3-1
III Operator Maintenance Procedures	3-13

TABLE OF CONTENTS

		Page	
CHAPTER 4	UNIT MAINTENANCE INSTRUCTIONS.....	4-1	
Section I	Lubrication Instructions.....	4-2	
II	Repair Parts; Special Tools; Test, Measurement, and Diagnostic Equipment (TMDE); and Support Equipment.....	4-3	
III	Service Upon Receipt.....	4-3	
IV	Equipment/User Fitting Instructions.....	4-4	
V	Unit Preventive Maintenance Checks and Services (PMCS).....	4-4	
VI	Unit Troubleshooting Procedures	4-10	
VII	Preparation for Storage or Shipment.....	4-31	
VIII	Unit Maintenance Instructions.....	4-32	
CHAPTER 5	DIRECT SUPPORT MAINTENANCE INSTRUCTIONS.....	5-1	
Section I	Repair Parts; Special Tools; Test, Measurement, and Diagnostic Equipment (TMDE); and Support Equipment.....	5-2	
II	Direct Support Troubleshooting	5-3	
III	Direct Support Maintenance Procedures.....	5-24	
CHAPTER 6	GENERAL SUPPORT MAINTENANCE INSTRUCTIONS.....	6-1	
Section I	Repair Parts; Special Tools; Test, Measurement and Diagnostic Equipment (TMDE); and Support Equipment.....	6-2	
II	General Support Maintenance Procedures.....	6-3	
APPENDIX A	REFERENCES.....	A-1	
APPENDIX B	MAINTENANCE ALLOCATION CHART.....	B-1	
APPENDIX C	REPAIR PARTS AND SPECIAL TOOLS LIST (RPSTL).....	C-1	
		Page	Illust/ Figure
Section I	INTRODUCTION.....	C-1	
Section II	REPAIR PARTS LIST.....	C-1-1	
Group 00	Auxiliary Power Unit 10kW, 120/240V, 60 Hz.....	C-1-1	C-1
Group 01	Generator 10kW, APU.....	C-2-1	C-2
Group 0101	Frame Assembly, SICPS.....	C-3-1	C-3
Group 0102	Frame Assembly, JTACS/WIN-T.....	C-4-1	C-4
Group 0103	Fuel Tank Assembly, SICPS.....	C-5-1	C-5
Group 0104	Fuel Tank Assembly, JTACS/WIN-T.....	C-6-1	C-6
Group 0105	Engine Assembly.....	C-7-1	C-7
Group 010501	Engine, Diesel, Turbo, 3 Cylinder, Liquid Cooled.....	C-8-1	C-8
Group 01050101	Lubricating System.....	C-9-1	C-9
Group 01050102	Cooling System.....	C-10-1	C-10
Group 01050103	Electrical System.....	C-11-1	C-11
Group 01050104	Fuel System.....	C-12-1	C-12
Group 0105010401	Injector Pump.....	C-13-1	C-13
Group 0105010402	Fuel Filter Assembly.....	C-14-1	C-14

Section II REPAIR PARTS LIST (cont'd)

		Page/illustr/	Figure
Group 01050105	Cylinder Head Assembly	C-15-1	C-15
Group 01050106	Connecting Rod	C-16-1	C-16
Group 0106	Fuel Pump Assembly.....	C-17-1	C-17
Group 0107	Radiator Subassembly	C-18-1	C-18
Group 0108	Speed Sensor Assembly	C-19-1	C-19
Group 0109	Wiring Harness, J3, DC Box, APU.....	C-20-1	C-20
Group 0110	Wiring Harness, Engine, P1	C-21-1	C-21
Group 0111	Wiring Harness, J1	C-22-1	C-22
Group 0112	Governor Control Assembly.....	C-23-1	C-23
Group 0113	Generator, 10kW, 60 Hz.....	C-24-1	C-24
Group 011301	Main Rectifier Assembly	C-25-1	C-25
Group 02	Wiring Harness, Control Cable	C-26-1	C-26
Group 03	APU Control Box Assembly.....	C-27-1	C-27
Group 0301	Wiring Harness J2	C-28-1	C-28
Group 99	Bulk Material.....		Bulk-1
Section II	SPECIAL TOOLS LIST	C-29-1	C-29
Section IV	CROSS-REFERENCE INDEXES	C-I-1	
	National Stock Number (NSN) Index	C-I-1	
	Part Number Index.....	C-I-7	
	Figure and Item Number Index	C-I-31	
APPENDIX D	COMPONENTS OF END ITEM AND BASIC ISSUE ITEMS LIST.....		D-1
APPENDIX E	ADDITIONAL AUTHORIZATION LIST		E-1
APPENDIX F	EXPENDABLE AND DURABLE PARTS ITEMS LIST		F-1
APPENDIX G	OPERATOR'S LUBRICATION INSTRUCTIONS		G-1
APPENDIX H	ILLUSTRATED LIST OF MANUFACTURED ITEMS.....		H-1
APPENDIX I	TORQUE LIMITS.....		I-1
APPENDIX J	MANDATORY REPLACEMENT PARTS.....		J-1
INDEX.....			INDEX-1
FOLDOUTS			FO1 – FO7

List of Illustrations

Figure	Title	Page
1-0.	Auxiliary Power Unit	1-0
1-1.	Auxiliary Power Unit Major Components (2 Sheets)	1-7
1-2.	Instructions and Warning Plates (3 Sheets)	1-12
1-3.	Combustion System	1-15
1-4.	Lubrication System	1-16
1-5.	Cooling System	1-17
1-6.	Fuel System.....	1-18
1-7.	Intake/Exhaust System.....	1-19
1-8.	Electrical System	1-20
1-9.	Main Stator and AVR Interface.....	1-21
1-10.	Engine Speed Control System	1-22
1-11.	Current Control	1-23
2-1.	APU Control Unit Front Panel	2-2
2-2.	Operator PMCS Routing Diagram (3 Sheets)	2-9
3-1.	Oil Dipstick.....	3-15
3-2.	Engine Oil	3-17
3-3.	Radiator Cap	3-19
3-4.	Radiator	3-21
4-1.	Engine Oil	4-33
4-2.	Oil Filter	4-35
4-3.	Oil Cooler.....	4-37
4-4.	Low Oil Pressure Switch (2 Sheets).....	4-39
4-5.	Fan Guard, Fan Shroud, and Shroud Housing (2 Sheets).....	4-43
4-6.	Radiator (3 Sheets)	4-46
4-7.	Radiator Coolant Drain Valve	4-51
4-8.	Engine Coolant Drain Valve	4-53
4-9.	Thermostat	4-55
4-10.	Fan Belt	4-57
4-11.	Radiator Hoses.....	4-59
4-12.	Temperature Sender	4-62
4-13.	Temperature Switch	4-64
4-14.	Breather (2 Sheets)	4-66
4-15.	Radiator Overflow Tank.....	4-69
4-16.	Fuel System.....	4-71
4-17.	Fuel Filter Assembly	4-74
4-18.	Fuel Pump Assembly	4-77
4-19.	Fuel Day Tank Assembly (JTACS and WIN-T).....	4-83
4-20.	Fuel Day Tank Assembly (SICPS)	4-87
4-21.	Fuel Feeder Pump.....	4-90
4-22.	Fuel Lines and Fittings (SICPS).....	4-93
4-23.	Fuel Lines and Fittings (JTACS and WIN-T).....	4-94
4-24.	Battery Charging Alternator.....	4-97
4-25.	Starter	4-99
4-26.	Glow Plug (2 Sheets).....	4-100
4-27.	Muffler Wrap	4-104
4-28.	Muffler (JTACS and WIN-T)	4-106
4-29.	Muffler (SICPS)	4-108
4-30.	Exhaust Pipe (JTACS and WIN-T).....	4-110
4-31.	Exhaust Pipe (SICPS).....	4-112

List of Illustrations (cont'd)

Figure	Title	Page
4-32.	Engine Turbocharger	4-114
4-33.	Air Filter (SICPS, JTACS and WIN-T) (2 Sheets).....	4-116
4-34.	Deleted	4-118
4-35.	Air Intake Pipe	4-120
4-36.	Governor Control Assembly	4-123
4-37.	Actuator/Solenoid (2 Sheets)	4-125
4-38.	Actuator Linkage (2 Sheets)	4-128
4-39.	Electrical Output Terminal Board	4-132
4-40.	Contacting Mounting Plate	4-135
4-41.	Main AC Contactor (2 Sheets)	4-137
4-42.	Ground Strap	4-140
4-43.	Current Shunt	4-143
4-44.	Speed Sensor	4-144.2
4-45.	Electrical Meters.....	4-148
4-46.	Hour Meter	4-150
4-47.	AC Voltage Adjust Potentiometer	4-153
4-48.	Emergency Shut-Down Switch	4-155
4-49.	Toggle Switches.....	4-157
4-50.	Momentary Toggle Switch	4-159
4-51.	Indicator Lamps.....	4-161
4-52.	Cylinder Head Cover (Valve Cover).....	4-163
5-1.	Oil Pan Cover	5-26
5-2.	Oil Pan.....	5-28
5-3.	Oil Pan Strainer	5-30
5-4.	Relief Valve	5-31
5-5.	Radiator Cap	5-32
5-6.	Water Pump	5-34
5-7.	Injection Nozzles (2 Sheets)	5-36
5-8.	Injection Pump (3 Sheets).....	5-41
5-9.	Current Transformer.....	5-45
5-10.	Overload Relay	5-47
5-11.	Contacting Plate	5-49
5-12.	Relay Board	5-52
5-13.	DC Box Subassembly	5-54
5-14.	Electromagnetic Safety Relays	5-57
5-15.	Relay Sockets	5-59
5-16.	Automatic Voltage Regulator (2 Sheets)	5-61
5-17.	Regulator Box	5-66
5-18.	Generator, 10 kW, 60 Hz (5 Sheets).....	5-71
5-19.	APU DC Box Wiring Harness J3.....	5-81
5-20.	Engine Wiring Harness P1	5-85
5-21.	Wiring Harness J1	5-89
5-22.	Water Temperature Gauge	5-94
5-23.	Wiring Harness J2.....	5-98
5-24.	Frame and APU Vibration Isolator Mount Assembly (6 Sheets)	5-104
5-25.	Diesel Engine (11 Sheets)	5-111
5-26.	Exhaust Manifold.....	5-126
5-27.	Intake Manifold.....	5-128
5-28.	Rocker Arm Assembly	5-130
5-29.	Valve Clearance.....	5-133
5-30.	Flywheel	5-135

List of Illustrations (cont'd)

Figure	Title	Page
6-1.	Push Rods.....	6-4
6-2.	Cylinder Head (4 Sheets).....	6-6
6-3.	Tappets	6-11
6-4.	Valves (3 Sheets).....	6-13
6-5.	Valve Guide.....	6-18
6-6.	Valve Spring.....	6-20
6-7.	Valve Seat (2 Sheets)	6-21
6-8.	Speed Control Plate	6-25
6-9.	Gear Case (2 Sheets)	6-28
6-10.	Idle Gear (2 Sheets).....	6-31
6-11.	Idle Gear Bushings.....	6-34
6-12.	Idle Gear Shaft	6-35
6-13.	Camshaft (4 Sheets)	6-37
6-14.	Camshaft Gear.....	6-42
6-15.	Fuel Camshaft.....	6-44
6-16.	Injection Pump Gear	6-46
6-17.	Crankshaft Gear.....	6-48
6-18.	Oil Pump Gear	6-49
6-19.	Piston (2 Sheets).....	6-51
6-20.	Connecting Rod (4 Sheets).....	6-55
6-21.	Piston Rings (4 Sheets)	6-60
6-22.	Bearing Case Cover	6-65
6-23.	Crankshaft.....	6-68
6-24.	Connecting Rod Bearing.....	6-70
6-25.	Crankshaft Bearing 1 (2 Sheets).....	6-72
6-26.	Crankshaft Bearings 2 and 3	6-75
6-27.	Cylinder	6-77
6-28.	Oil Pump Assembly (2 Sheets)	6-79
6-29.	Radiator Seal Faring	6-81
6-30.	Water Flange.....	6-83
6-31.	Exciter Stator (4 Sheets).....	6-85
6-32.	Main Rectifier Assembly.....	6-89
6-33.	Generator Bearing.....	6-90
6-34.	Rotor.....	6-92
D-1.	Auxiliary Power Unit, 10 kW, 120/240 VAC, 60 Hz.....	D-3
D-2.	Operator's, Unit, Direct Support, and General Support Maintenance Manual	D-4
FO-1.	APU Wiring Diagram (SICPS and WIN-T).....	FO-1
FO-2.	Wiring Harness, Engine P1 Wiring Diagram.....	FO-2
FO-3.	Wiring Harness, APU DC Box J3 Wiring Diagram.....	FO-3
FO-4.	Wiring Harness, J1 Wiring Diagram.....	FO-4
FO-5.	Wiring Harness, J2, APU Control Box, Wiring Diagram	FO-5
FO-6.	Wiring Harness, Control Cable Wiring Diagram	FO-6
FO-7.	APU Wiring Diagram (JTACS).....	FO-7

List of Tables

Number	Title	Page
1-1.	Differences Between Models	1-5
2-1.	APU Control Unit Controls and Indicators.....	2-3
2-2.	Operator Preventative Maintenance Checks and Services (PMCS) for Auxiliary Power Unit, 10 kW, 120/240 VAC, 60 Hz	2-4
2-3.	Control Unit Start-Up Switch Positions	2-12
3-1.	Ambient Temperature and Engine Oil Type	3-16
3-2.	Freezing Points, Composition, and Specific Gravities	3-20
4-1.	Freezing Points, Composition, and Specific Gravities of Military Antifreeze Materials	4-4
4-2.	Unit Preventive Maintenance Checks and Services (PMCS).....	4-7
5-1.	APU DC Box Wiring Harness J3 Continuity Test.....	5-77
5-2.	Engine Wiring Harness P1 Continuity Test.....	5-81
5-3.	Wiring Harness J1 Continuity Test.....	5-85
5-4.	Wiring Harness Control Cable Continuity Test	5-88
5-5.	Wiring Harness J2 Continuity Test.....	5-94
6-1.	Undersize Connecting Rod Bearing.....	6-69
6-2.	Undersize Crankshaft Bearing I	6-71
6-3.	Undersize Crankshaft Bearings 2 and 3	6-74
E-1.	Additional Authorization List	E-2
G-1.	Lubricant Table for the APU.....	G-2
H-1.	Materials and Specifications.	H-3
H-2.	Chamfer and Fine Finish Requirements.	H-3
H-3.	Materials and Specifications.	H-5
H-4.	Chamfer and Fine Finish Requirements.	H-5
H-5.	Materials and Specifications.	H-7
H-6.	Chamfer and Fine Finish Requirements.	H-7
H-7.	Materials and Specifications.	H-9
H-8.	Chamfer and Fine Finish Requirements.	H-9
H-9.	Parts, Materials, and Specifications.	H-11
H-10.	Chamfer and Fine Finish Requirements.	H-11
I-1	Torque Values for Special Use Screws, Belts and Nuts.....	I-1
I-2	Torque Values for Special Use Screws, Belts and Nuts.....	I-2
I-3	Torque Values for Special Use Screws, Belts and Nuts.....	I-2

HOW TO USE THIS MANUAL

This manual tells you how to operate and maintain Auxiliary Power Unit, 10 KW, 120/240 VAC, 60 HZ.

Step-by-step procedures with illustrations give you all the necessary information to install, operate, and maintain this equipment at operator, unit, direct support and general support levels. However, do not attempt any procedure before you first familiarize yourself with the entire procedure.

The front cover index identifies frequently used information. Each item is boxed and identified by topic and page number.

The first page containing the information you are looking for has a black box on the edge of the paper. Bend the manual in half and follow the margin index to the page with the black edge marker. Topics in the table of contents which are the same as topics on the front cover are also boxed.

If you are looking for general information, use the table of contents in the front of this manual to locate chapters and sections containing this information.

If you are looking for specific information, use the chapter index in the front of each chapter or the alphabetical index located in the back of the manual to locate the paragraph and page where the topic is discussed.

The glossary contains an explanation of technical terms and acronyms.

Foldout illustrations are located in the back of this manual.

NOTE: Contains information of special interest or of importance.

CAUTION: Contains conditions, practices, or procedures that must be observed to avoid damage to the equipment.

WARNING : Contains conditions, practices, or procedures that must be observed to avoid personal injury, loss of life, or long term health hazard.

THIS PAGE INTENTIONALLY LEFT BLANK

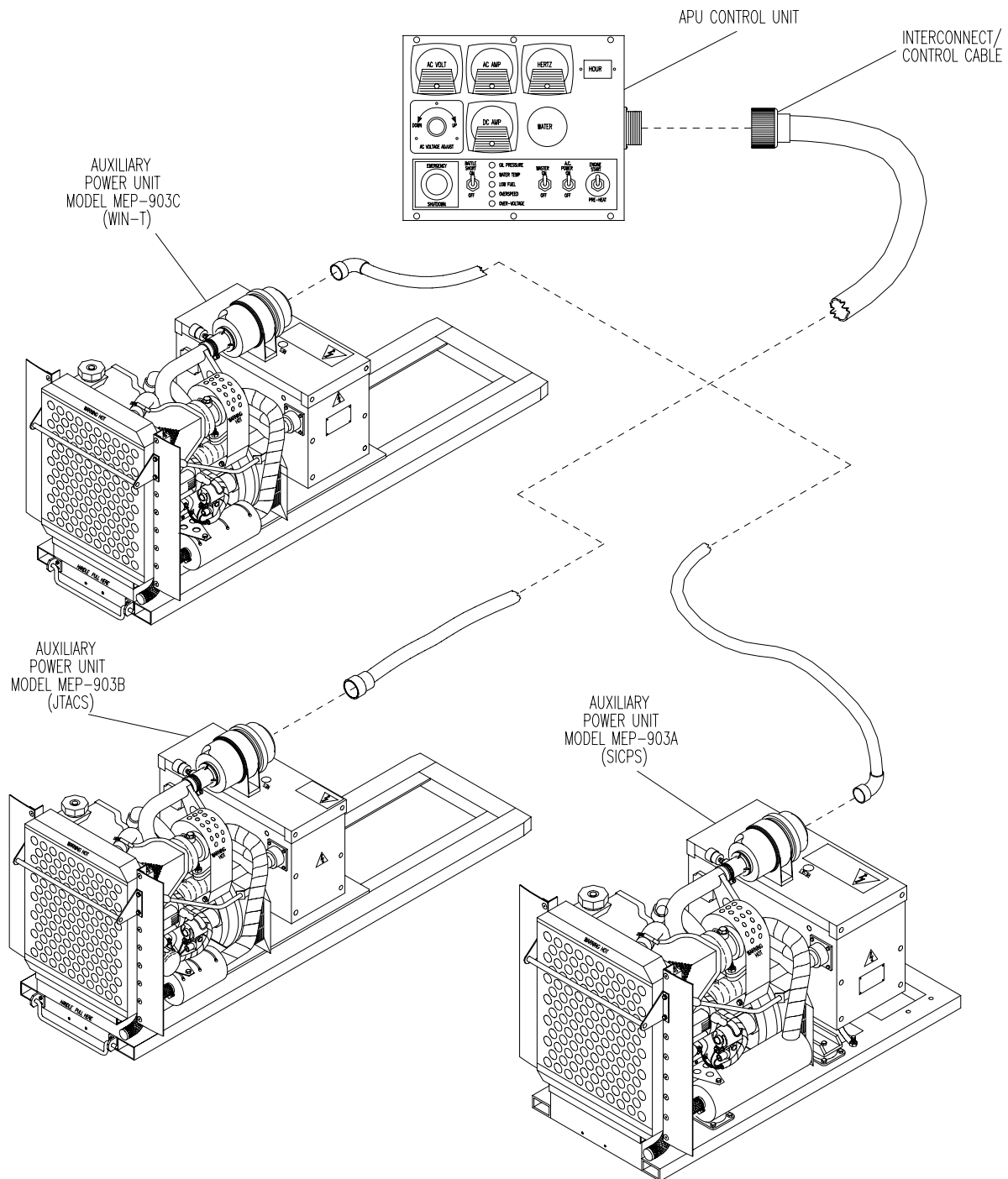

Figure 1-0. Auxiliary Power Unit

CHAPTER 1

INTRODUCTION

Section I. GENERAL INFORMATION

1.1. SCOPE.

1.1.1. Type of Manual. This technical manual provides a general description; theory of operation; operating instructions; operator, unit, direct support, and general support troubleshooting; preventive maintenance; and corrective maintenance instructions for the Auxiliary Power Unit 10 kW, 120/240 VAC, 60 Hz (Figure 1-1).

NOTE

This manual will indicate if certain procedures apply to either WIN-T, JTACS, or SICPS. Unless indicated, the procedure applies to all three configurations.

NOTE

Refer to "Table 1-1. Differences Between Models" for differences between MEP-903A, MEP-903B and MEP-903C, which may not be depicted in the TM illustrations.

1.1.2. Equipment Name and Model Number. The equipment covered in this manual is called the Auxiliary Power Unit, 10 kW, 120/240 VAC, 60 Hz (APU), MEP-903A (SICPS), MEP-903B (JTACS), or MEP-903C (WIN-T).

1.1.3. Purpose of Equipment. The APU is a light weight power supply designed for use with Standard Integrated Command Post System (SICPS) and Joint Tactical Area Communications System (JTACS) shelters. It fits into the SICPS or JTACS shelter tunnel and supplies sufficient power to operate installed shelter equipment when external power is not available, or during mobile operation.

1.2. MAINTENANCE FORMS, RECORDS, AND REPORTS.

Department of the Army forms and procedures used for equipment maintenance will be those prescribed by DA PAM 738-750 as contained in the Maintenance Management Update.

1.3. ADMINISTRATIVE STORAGE.

Administrative storage of equipment issued to and used by Army activities will have preventive maintenance performed in accordance with the PMCS charts before storing. When removing the equipment for administrative storage, the PMCS should be performed to assure operational readiness.

1.4. DESTRUCTION OF ARMY MATERIEL TO PREVENT ENEMY USE.

Destruction of Army and Marine Corps electronics materiel to prevent enemy use shall be in accordance with TM 750-244-3.

ARMY TM 9-6115-670-14&P

1.5. NOMENCLATURE CROSS-REFERENCE LIST.

COMMON NAME	OFFICIAL NOMENCLATURE
APU	Auxiliary Power Unit
HHMMWV or Vehicle	Heavy High Mobility Multipurpose Wheeled Vehicle
HMMWV or Vehicle	High Mobility Multipurpose Wheeled Vehicle
SICPS shelter	Shelter, Standardized Integrated Command Post System, Version 3
JTACS shelter	Shelter, Joint Tactical Area Communications System
WIN-T	War Fighter Information Network - Terrestrial

1.6. REPORTING EQUIPMENT IMPROVEMENT RECOMMENDATIONS (EIRs).

If your APU needs improvement, let us know. Send us an EIR. You, the user, are the only one who can tell us what you don't like about your equipment. Let us know why you don't like the design or performance. Put it on an SF 368 (Product Quality Deficiency Report). Mail it to: Commander, U.S. Army Communications and Electronics Command, ATTN: AMSEL-LC-LEO-D-CS-CFO, Fort Monmouth, New Jersey 07703-5000. We will send you a reply.

1.7. WARRANTY INFORMATION.

The warranty starts on the date found in block 23, DA Form 2408-9 in the logbook. Report all defects in material and workmanship to your supervisor, who will take the appropriate action.

1.8. CORROSION PREVENTION AND CONTROL (CPC).

Corrosion prevention and control of Army material is a continuing concern. It is important that any corrosion problems with this item be reported so that the problem can be corrected and improvements can be made to prevent the problem in future items. While corrosion is typically associated with rusting of metals, it can also include deterioration of other materials, such as rubber and plastic. Unusual cracking, softening, swelling, or breaking of these materials may be a corrosion problem. If a corrosion problem is identified, it can be reported using Standard Form 368, Product Quality Deficiency Report. Use of key words such as "corrosion", "rust", "deterioration", or "cracking" will ensure that the information is identified as a CPC problem. Standard Form 368 should be submitted to: Commander, U.S. Army Communications and Electronics Command, ATTN: AMSEL-LC-LEO-D-CS-CFO, Fort Monmouth, New Jersey 07703-5000.

1.9. LIST OF ABBREVIATIONS.

AC	Alternating Current
AVR	Automatic Voltage Regulator
AOAP	Army Oil Analysis Program
ccw	Counter Clockwise
cm	Centimeters
cw	Clockwise
DC	Direct Current
DISREP	Discrepancy in Shipment Report
EIR	Equipment Improvement Recommendation
ft-lbs	Foot-pounds
FM	Field Manual

Hz	Hertz
ID	Inside diameter
in.	Inch
kW	Kilowatt
kPa	Kilo-Pascal
l	Liter
MAC	Maintenance Allocation Chart
MPa	Mega-Pascal
mm	Millimeter
Nm	Newton Meters
OD	Outside diameter
pf	Power Factor
PMCS	Preventive Maintenance Checks and Services
PSI	Pound-force per Square Inch
psig	Pound-force per Square Inch Gauge
RPSTL	Repair Parts and Special Tools List
TAMMS	The Army Maintenance Management System
TDR	Transportation Discrepancy Report
TM	Technical Manual
TMDE	Test Measurement and Diagnostic Equipment
V	Volt
VAC	Volt Alternating Current
VDC	Volt Direct Current

1.10. GLOSSARY.

Actuator/solenoid	Device with an output shaft that moves linearly when current is applied
Alternator	Device used to generate AC used to charge battery after conversion to DC
Automatic Voltage Regulator	Device that regulates APU AC output
Combustion	Burning of an air/fuel mixture in a closed cylinder to produce a force
Contactora	Device that establishes and interrupts the main output circuit of the APU
Diesel engine	Engine wherein combustion is caused by compression of fuel mixture
Excitation	Supplying the electric current used to produce a magnetic field in a generator
Filter	Device used to remove dirt or water from lubricating oil or fuel
Glow Plug	Device used to warm a combustion chamber to facilitate cold start up
Governor	Device which controls engine speed by controlling fuel flow to engine

ARMY TM 9-6115-670-14&P

Injection nozzle	Nozzle which injects fuel into engine until combustion takes place
Overload Relay	Safety device that opens the contactor in conditions of high current or low voltage
Relay Board	Device that routes electrical signals within the APU
Rotor	The part of the generator that rotates within the stator
Starter	Device used to turn over an engine until it starts (combustion takes place)
Stator	The part of the generator that remains stationary
Thermostat	Device used to regulate engine coolant temperature by controlling coolant flow
Voltage rectification	Conversion of AC voltage to DC voltage

Section II. EQUIPMENT DESCRIPTION

1.11. EQUIPMENT CHARACTERISTICS, CAPABILITIES, AND FEATURES.

1.11.1. Characteristics. The APU is a diesel engine driven, slide frame mounted, 10 kW, 60 Hz, single phase, 3-wire 120/240 VAC unit which is used to supply electrical power for mission equipment mounted in SICPS or JTACS shelters. It is installed in the SICPS or JTACS tunnel. The SICPS is normally mounted on a HMMWV while the JTACS is mounted on a HHMMWV. In both shelters, the APU utilizes the vehicle's fuel tank and batteries to reduce its weight.

1.11.2. Capabilities. The APU will start and run continuously, delivering a rated load of 10 kW at 0.8 power factor (PF) lagging, in all temperatures for -25°F to +125°F (-31.7°C to 51.6°C) at sea level. It will provide a minimum of 10 kW at an altitude of 5000 feet (1524 meters) and a temperature of +107°F (41.6°C). It will provide a minimum of 10 kW at an altitude of 8000 feet (2438.4 meters) and a temperature of +95°F (35°C).

1.11.3. Features. The APU is a light weight (495 pounds (225 kg) (SICPS; WIN-T); 461 pounds (172 kg) (JTACS)) unit consisting of a 3600 rpm, turbo charged, liquid cooled, diesel engine coupled directly to a two pole, 10 kW, 0.8 PF, 60 Hz generator, with excitation system (voltage regulator included); starter; controls; 28 volt battery-charging system (alternator); electric governor; aluminum frame; shock and vibration isolators, and mounting provisions to interface with the SICPS, JTACS or WIN-T. The APU can be operated with the vehicle moving or stationary.

1.12. DIFFERENCES BETWEEN MODELS.

Table 1-1 details equipment differences between models MEP-903A (SICPS configuration), MEP-903B (JTACS configuration), and MEP903C (WIN-T configuration).

Table 1-1. Differences Between Models

	MEP903A (SICPS)	MEP903B (JTACS) AND MEP903C (WIN-T)
Frame Assembly:		
Length	34.50 in. (87.63 cm)	70.62 in. (179.37 cm)
Width	19.75 in. (50.17 cm)	20.12 in. (51.10 cm)
Pull Handle	None	One screw mounted pull handle
Runners	Two screw mounted runners	None
Day Tank (fuel tank)		
Mounting Bracket width (Fuel Transfer Pump Side)	5.38 in. (13.67 cm)	3.34 in. (8.48 cm) (WIN-T) 3.50 in. (8.89 cm) (JTACS)
Mounting Bracket width (Muffler Side)	3.25 in. (8.26 cm)	3.34 in. (8.48 cm) (WIN-T) 3.50 in. (8.89 cm) (JTACS)
Length	13.40 in. (34.04 cm)	10.00 in. (25.40 cm)
Width	3.25 in. (8.26 cm)	3.34 in. (8.48 cm) (WIN-T) 3.50 in. (8.89 cm) (JTACS)
Depth (Narrow Side)	3.09 in. (7.85 cm)	3.00 in. (7.62 cm)
Depth (Sump Side)	4.50 in. (11.43 cm)	3.00 in. (7.62 cm)
Muffler Wrap	Configured to fit SICPS Model Only	Configured to fit WIN-T Model Only Configured to fit JTACS Model Only
Muffler		
Diameter	5.04 in. (12.80 cm)	3.54 in. (8.99 cm) (WIN-T) 3.69 in. (9.37 cm) (JTACS)
Length	11.50 in. (29.21 cm)	9.64 in. (24.49 cm) (WIN-T) 9.63 in. (24.45 cm) (JTACS)
Installation	Mounts to exhaust pipe with muffler bracket	Mounts to exhaust pipe with three bolts, lock washers, and one muffler gasket
Exhaust Pipe	Mounts to muffler with muffler bracket	Mounts to muffler with three bolts and lock washers
Control Unit	Fault indicator lights interface with connector J2 and SPS6 through Terminal Board TB1	Fault indicator lights interface directly with connector J2 and SPS6
Air Filter		
Length	7-5/16"	7-5/16"
Diameter	3.5"	3.5"

1.13. LOCATION AND DESCRIPTION OF MAJOR COMPONENTS.

1.13.1. Engine (1, Figure 1-1). The APU power source is a three cylinder, four cycle, turbo charged, fuel injected, liquid cooled diesel engine. The engine's electrical system contains a starter and a battery charging alternator with integral rectifier and voltage regulator. The APU control and starting voltage of 28 volts is provided from the host vehicle battery and from a 20 ampere DC alternator when the engine is running. The engine is also equipped with a fuel filter, oil filter, and an air filter. Coolant is circulated through the engine by a water pump. Safety devices automatically stop the engine during conditions of high coolant temperature, low oil pressure, low fuel, over-speed, or over-voltage.

1.13.2. Generator (2). The AC generator is a single bearing, drip-proof, synchronous, brushless, single phase, fan-cooled generator. Rated voltage is maintained by excitation of the generator-excitation field by a static exciter. The fan, located at the front of the generator, impels air which enters the generator and passes over the windings. Safety devices are provided to protect the generator in the event of overload and over-voltage.

1.13.3. Governing System (3). The APU governor system senses speed and load electrically and provides the controls and load responses necessary to maintain the APU frequency requirements for efficient APU operation.

1.13.4. Lubrication System (4). The APU engine has a lubrication system which consists of an oil pump, oil filter, oil strainer, relief valve, oil pressure switch, and oil lines necessary to provide adequate oil circulation for all APU operating conditions. This engine can be operated up to 100 hours between oil changes. An oil pressure transducer sends a signal to the APU control panel, where a corresponding status light provides the operator with a warning indication when adequate oil pressure is lost. Lack of adequate oil pressure will cause the engine to shut down, unless the APU is operating in the BATTLE SHORT ON mode.

1.13.5. Fuel System (5). The APU engine operates on diesel fuels DF-1, DF-2, and DF-A (when operating in an arctic climate). The APU is equipped with a small fuel reservoir having two fuel sensors. Sensor one senses the need for more fuel and, when required, energizes the fuel transfer pump. Sensor two senses that a critical low fuel level has occurred, and sends a signal to the control panel which energizes a status light and shuts down the engine prior to complete fuel starvation, preventing the need to prime the fuel system.

1.13.6. Cooling System (6). The APU is equipped with a pressurized liquid cooling system consisting of a radiator, centrifugal water pump, suction fan, thermostat, temperature sensor (high coolant temperature), coolant drains, and a filler cap. Coolant circulation is controlled by the thermostat (which operates at a coolant temperature of approximately 180°F (82.2°C) to maintain safe engine operating temperatures. The temperature sensor monitors the coolant temperature and sends a signal to the coolant temperature indicator on the control panel. When the coolant temperature reaches a level at which the engine will over heat 230°F (110°C), a signal is sent to shut down the APU before engine damage can occur. As with the low oil pressure condition, the APU will not shut down at the high coolant condition when operating in the BATTLE SHORT ON mode.

1.13.7. APU Control Unit (7). The APU controller contains instrumentation and controls for operating the engine and the generator. The control panel is grounded to protect the operator from electrical shock in the event of a short in the electrical system. The APU controller contains meters for monitoring APU output, an adjustment for increasing and decreasing voltage, a circuit breaker switch for interrupting output from the APU, and switches for preheating, starting, and stopping the APU. An ammeter is also provided for monitoring the 20 AMP DC alternator.

1.13.8. Wiring Harness Control Cable (8). A wiring harness control cable is provided with the APU to connect the APU to the control panel. This cable contains 25 leads with a 25-pin connector at each end. As installed in SICPS shelters, the APU and the APU controller are not directly connected. One end of the control cable is plugged into a receptacle on the rear of the APU. The other end of the control cable is connected to the shelter power distribution vault where the signals are passed through EMI filters. The APU controller, which is panel mounted inside the shelter, is connected to the power distribution box by internal SICPS cabling. In JTACS shelters, the control cable connects the APU to a bulkhead connector next to the power entrance box. A second cable (interconnect harness) connects the bulkhead connector to the control unit (9).

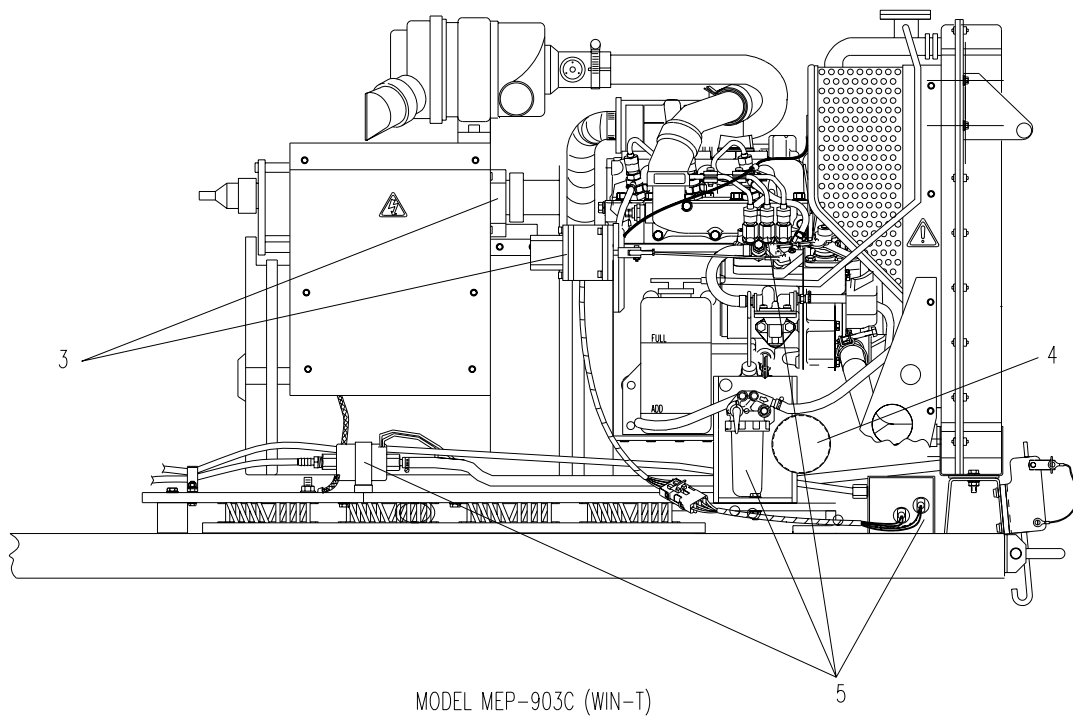
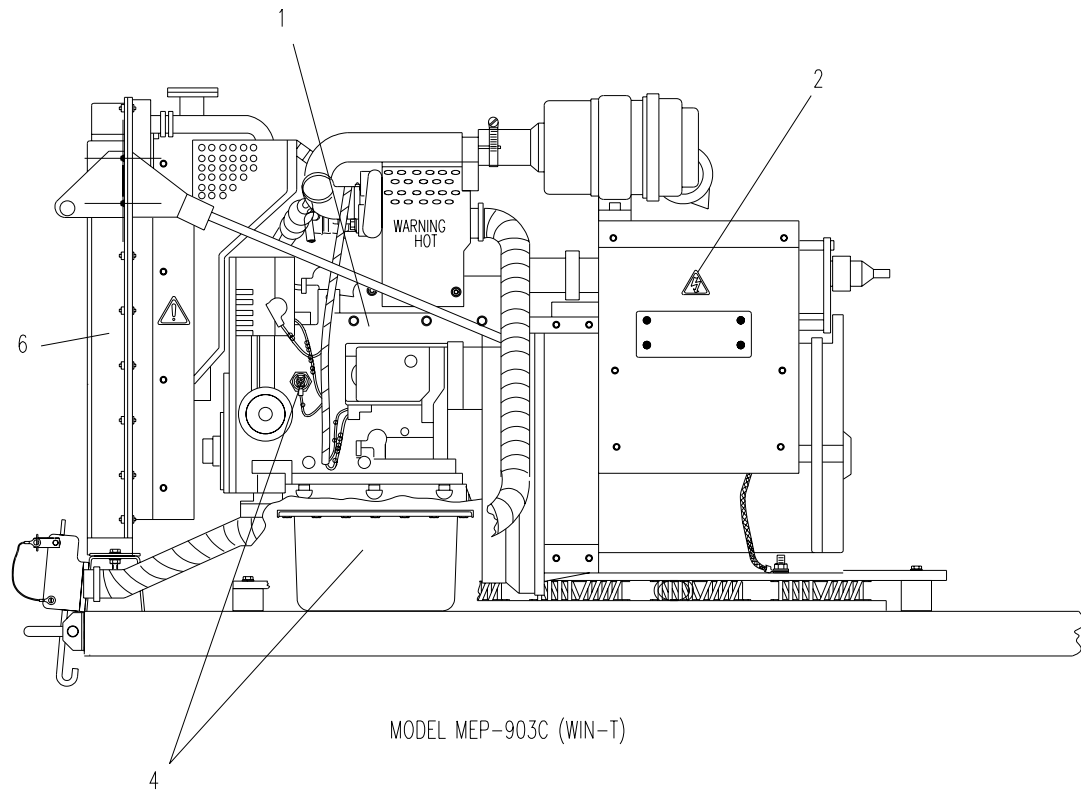

Figure 1-1. Auxiliary Power Unit Major Components (Sheet 1 of 2)

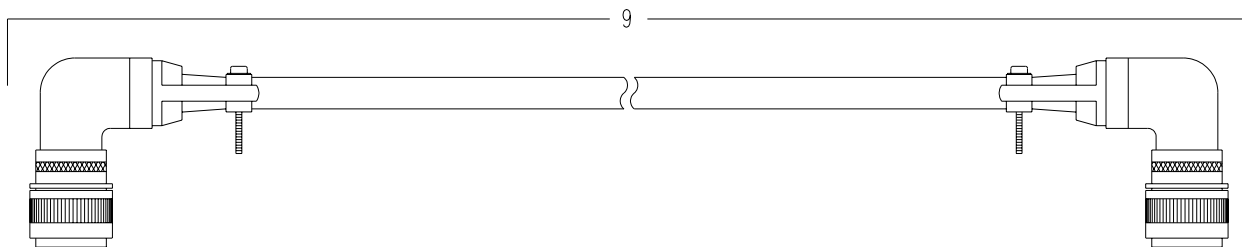
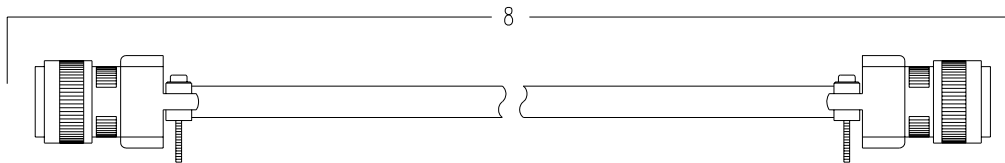
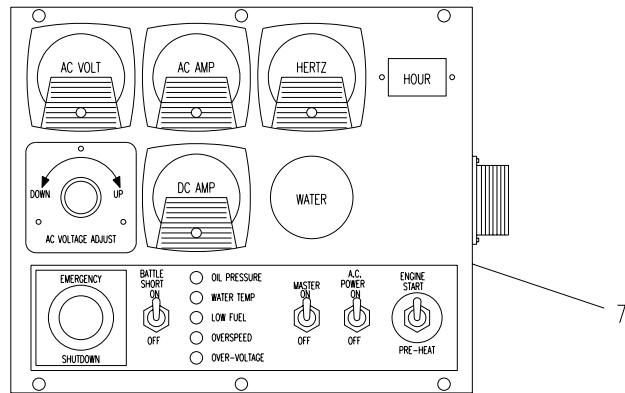

Figure 1-1. Auxiliary Power Unit Major Components (Sheet 2)

1.14. EQUIPMENT DATA.

1.14.1. Auxiliary Power Unit.

Manufacturer	KECO Corporation (SICPS, WIN-T) CENTRAIR Corporation (JTACS)
Model	Enviropower 10/10 kW
Height	27.88 in. (70.82 cm)
Width	18.0 in. (45.72 cm) (SICPS/WIN-T) 26.50 in. (67.31 cm) (JTACS)
Length	26.0 in. (66.04 cm) (SICPS/WIN-T) 36.00 in. (91.44 cm) (JTACS)
Dry Weight	509 lbs. (230.88 kg) (SICPS/WIN-T) 461 lbs. (209.11 kg) (JTACS)
Wet Weight	525 lbs. (238.14 kg) (SICPS/WIN-T) 473 lbs. (214.55 kg) (JTACS)

1.14.2. Engine.

Manufacturer	Kubota, Ltd.
Model	D722-B
Type	Diesel, 3-cylinder, 4-cycle
Rated Horsepower (at 3600 RPM)	16.3 Continuous
Firing order	1-2-3
Valve Clearance (Cold)	0.0057 to 0.0073 in. (0.14478 to 0.18542 mm)
Dry Weight	139.1 lbs. (63.05 kg)

1.14.3. Generator.

Manufacturer	Newage International, Ltd.
Model	UCI162C16
Type	Single bearing, drip-proof, synchronous, liquid cooled, turbo-charged brushless, single phase, fan-cooled
Load Capacity (at 3600 RPM)	10 kW at 60 Hz
Current Rating	52.1 amps at 120/240 VAC
Power factor	0.8 lagging
Cooling	Impeller fan
Lubrication	None required
Drive Type	Direct coupling
Duty Classification	Continuous

1.14.4. Governing System.

Manufacturer	Barber Coleman
Control Assy P/N	DYN1-10704-0-0-24
Actuator P/N	DYNC-10502-0-0-24
Sensor P/N	DYNT 17200

1.14.5. Lubrication System.

Type	Pump forced lubrication
Oil Pump Type	Trochoid

ARMY TM 9-6115-670-14&P

Normal Operating

Pressure:

At Idle Speed	14 psig (96.53 kPa)
At Rated Speed	28 to 64 psig (193.05 to 441.26 kPa)
Oil Filter Type	Full Flow, Replaceable Element
Pressure Transmitter	
Voltage Rating	24 VDC
Resistance at Pressure (Ohms at psi)	32 ohms at 64 psi (32 ohms at 220.63 kPa)
System Capacity	3.5 qt. (3.31 l)

1.14.6. Fuel System.

a. Fuel Transfer Pump.

Voltage	24 VDC
Delivery Pressure	7 psig (4.8 kPa) (max.)
Delivery Rate	18 gal./hr. (68.13 l/hr.) (max.)

a.1. Fuel Pump Mechanical

Fuel Feed Quantity (at 1500 camshaft RPM)	13.73 cu. in./min (225 cc/min)
--	-----------------------------------

a.2. Fuel injection Pump

Type	Bosch MD Mini Pump
------	--------------------

b. Fuel Level Switches.

Type	Float
Current	3.0 amps at 6 to 32 VDC
Pressure	0 to 150 psig (0 to 1.03 MPa)
Over Travel	
High	0.06 in. (1.52 mm) (min.)
Low	0.12 in. (3.05 mm) (min.)

c. Fuel Injection Nozzle Holder.

Cracking Pressure	1991 to 2133 psig (13.72 to 14.71 MPa)
-------------------	--

1.14.7. Cooling System.

Type	Pressurized Radiator & Centrifugal Pump
Capacity	1.2 gal. (5.54 l)
Normal Operating Temperature	170°F (77°C) to 200°F (93°C)
Transmitter	
Voltage Rating	24 VDC
Resistance (ohms) at Temperature °F	2360 ±236 at 120°F (49°C) 710 ±35.5 at 200°F (93°C) 310 ±24.8 at 280°F (138°C)

1.14.8. Engine Electrical System.

a. Batteries.	APU Utilizes Vehicle Batteries (24 VDC)
---------------	---

b. Starter Assembly.

Manufacturer	Kubota, Ltd.
Model	19883-63010
Voltage	24 VDC
Drive Type	Positive Indexing With Over-Run Clutch

c. Battery Charging Alternator.

Manufacturer	Kubota, Ltd.
Model	19883-6400
Rating	20 amps at 24 VDC
Operating Temperature Range	-65°F to +175°F (-68.1°C to 65.2°C)
Current Output	0 to 20 amp at 1900 to 4000 rpm

1.15. INSTRUCTIONS AND WARNING PLATES.

<u>ITEM</u>	<u>DESCRIPTION</u>
a. Identification Plate	Provides official nomenclature and model of APU (SICPS and WIN-T only).
b. Wiring Diagram Plate	Displays wiring diagram of APU (SICPS and WIN-T only. JTACS wiring diagram is located in container under housing cover.).
c. Warning Label	Cautions user to refer to manual before removing cover.
d. AVR Plate	Provides instructions for connection of Automatic Voltage Regulator.
e. Relay Board Diagnostic Indicator Guide	Provides instructions for interpreting relay board diagnostic indicator lights.

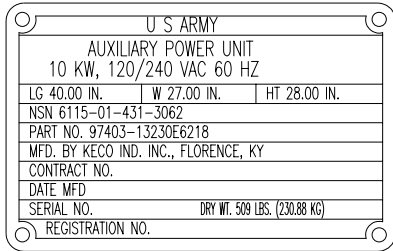

(SICPS)

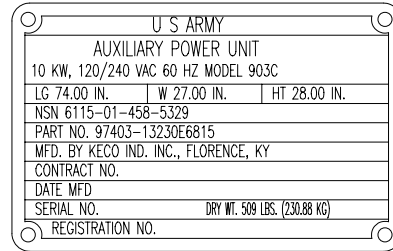

(WIN-T)

a. PLATE, IDENTIFICATION

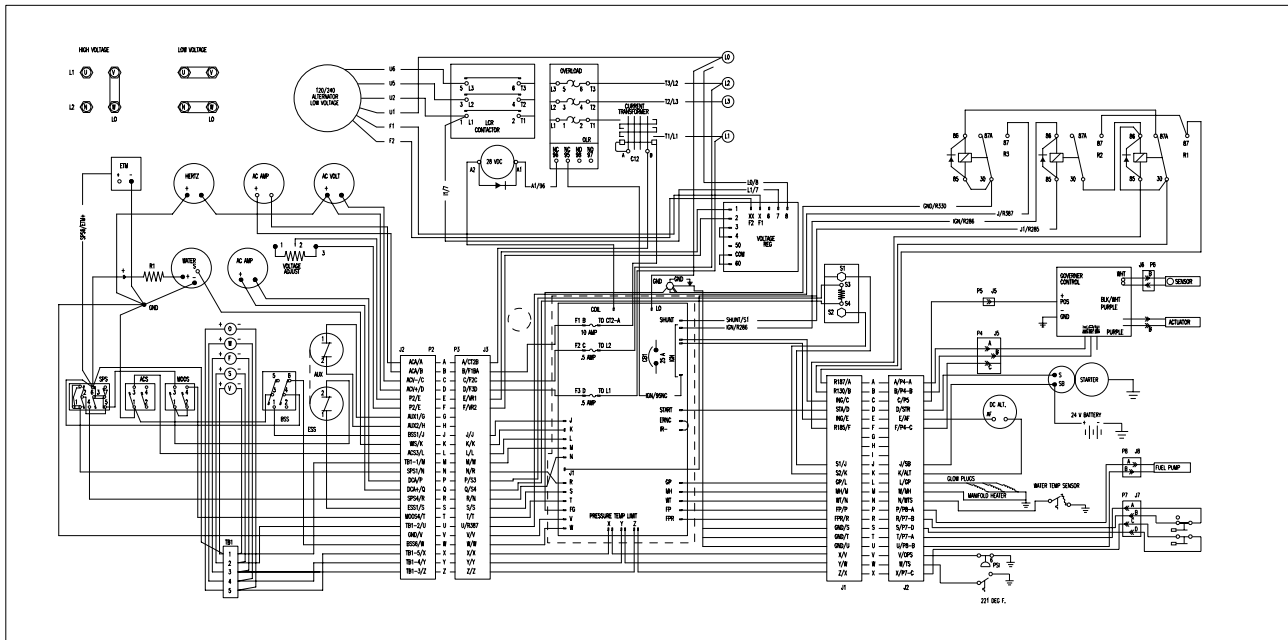

b. APU WIRING DIAGRAM (SICPS AND WIN-T)

Figure 1-2. Instructions and Warning Plates (Sheet 1 of 3)

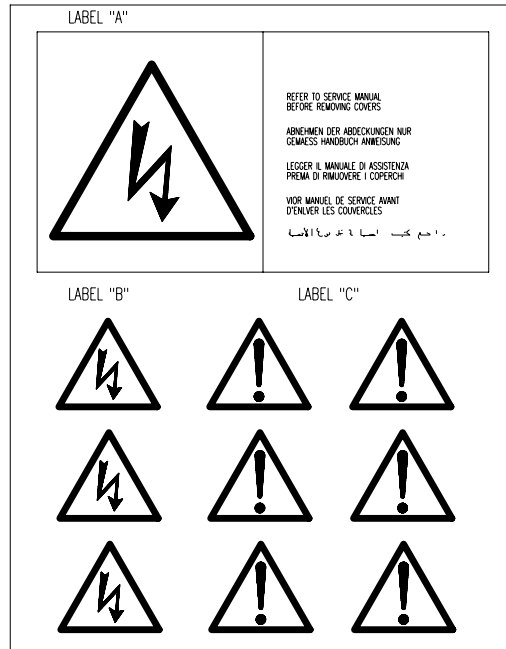

(SICPS, WIN-T and JTACS)

c. GENERATOR WARNING LABELS

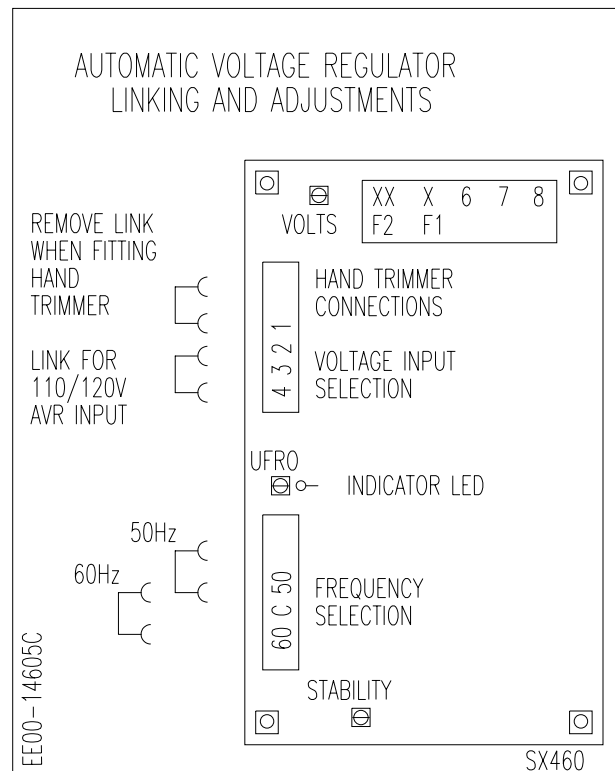

d. AUTOMATIC VOLTAGE REGULATOR INSTRUCTION PLATE

Figure 1-2. Instructions and Warning Plates (Sheet 2)

RELAY BOARD DIAGNOSTIC INDICATOR GUIDE

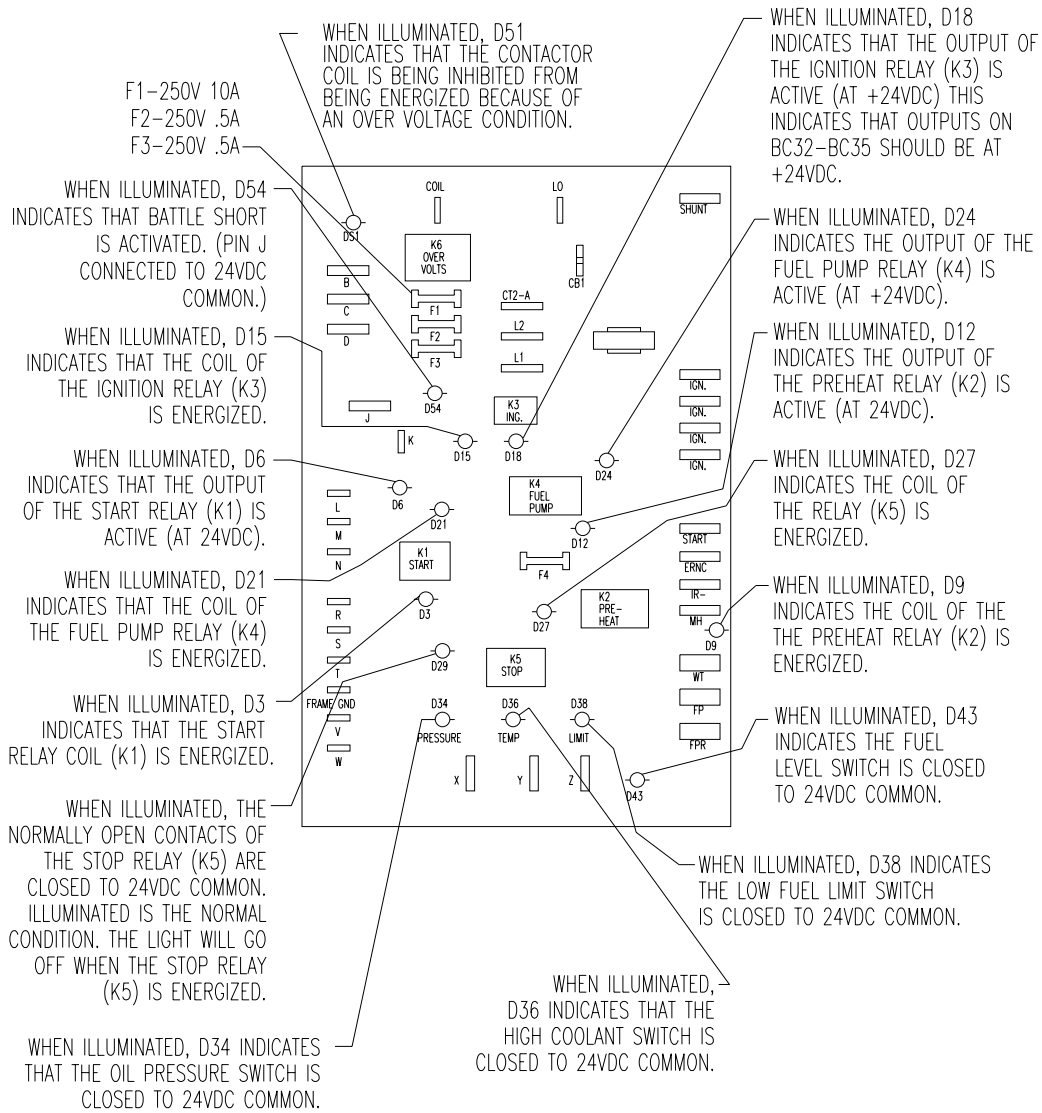

e. RELAY BOARD DIAGNOSTIC INDICATOR DECAL

Figure 1-2. Instructions and Warning Plates (Sheet 3)

Section III. PRINCIPLES OF OPERATION

1.16. ENGINE OPERATION.

1.16.1. Combustion System. The engine operates on the typical diesel combustion cycle (Figure 1-3). To improve efficiency in the APU's small engine, the combustion chamber of each cylinder has a three-lobe throat in the air inlet. This produces three streams of air in the chamber, creating an ideal mixture of air and fuel. The top of each piston has a fan-shaped indentation, allowing smooth ejection of exhaust gas. The cross-flow intake/exhaust ports in this engine have their openings at both sides of the cylinder head. Because overlaps of the intake/exhaust ports are comparatively small, the suction air is protected from being heated and expanded by the heated exhaust air. Therefore, the cool, high density suction air has high volume efficiency and raises the power of the engine. Throttle type injection nozzles and rapid heating sheathed type glow plugs are installed in each cylinder combustion chamber. In addition, a preheating glow plug is installed in the intake manifold. The engine will start easily at 5°F (-14°C).

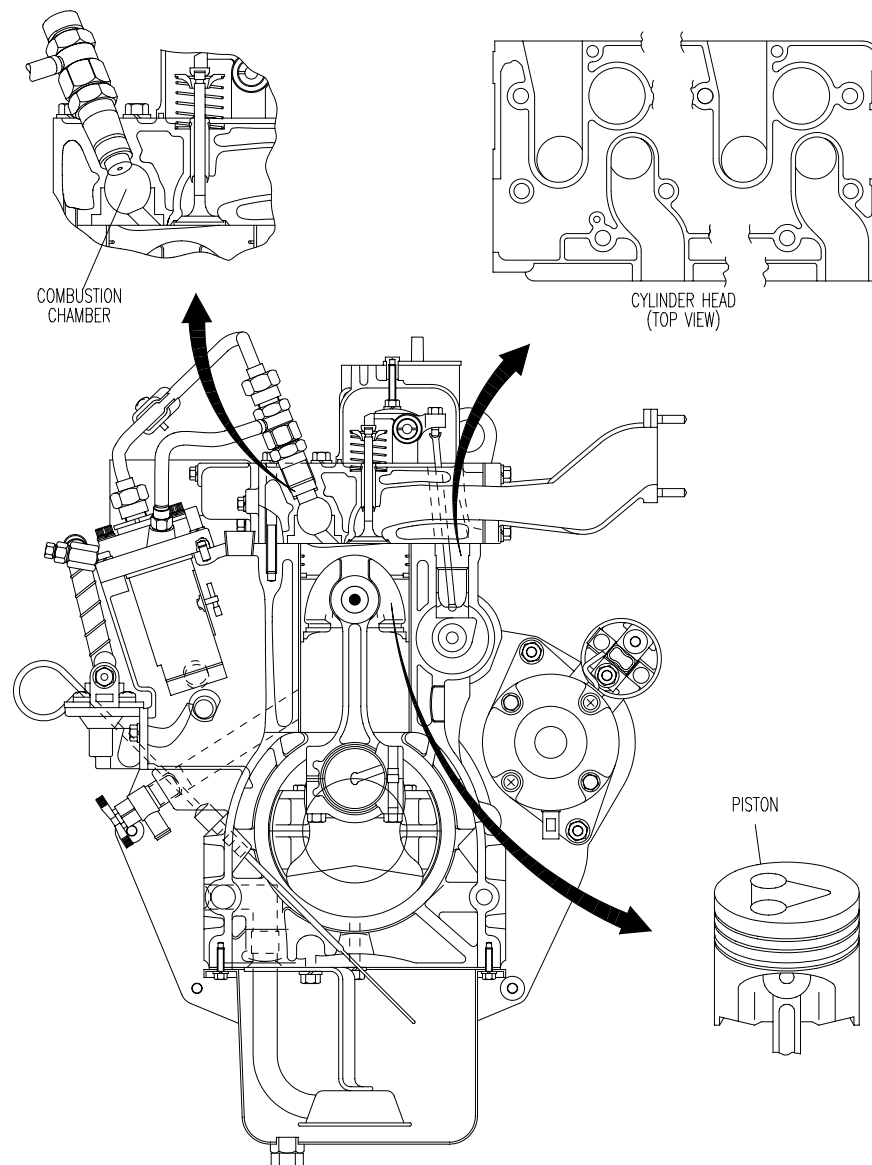

Figure 1-3. Combustion System

1.16.2. Lubrication System. The engine's lubricating system (Figure 1-4) consists of an oil strainer, oil pump, relief valve, oil filter cartridge, oil cooler, and low oil pressure switch. The oil pump forces lubricating oil from the oil pan through the oil strainer and to the oil filter where it is further filtered. The oil is then forced to the crankshaft, connecting rods, idle gear, camshaft and rocker arm shaft to lubricate each part. Pistons, cylinders, small ends of connecting rods, tappets, pushrods, inlet valves, exhaust valves, and timing gear are lubricated by oil splashed by the crankshaft or leaking from lubricated parts. The relief valve prevents damage to the lubricating system when pressure becomes too high. When the oil pressure, forced by the pump becomes too high, the oil pushes back the ball in the valve and escapes into the pan. The lubricating oil, force fed by the pump, brings back particles of dirt and grit to the oil filter element in the filter cartridge. When the element accumulates an excessive amount of dirt, building up the oil pressure, a bypass valve in the filter opens to allow the oil to flow from the inlet into the outlet line, bypassing the filter element. The low oil pressure switch, mounted on the engine block, is open when the oil pressure is 7 psi (48.26 kPa) or greater. When the oil pressure falls below 7 psi (48.26 kPa), the switch closes, illuminating a warning light on the APU controller.

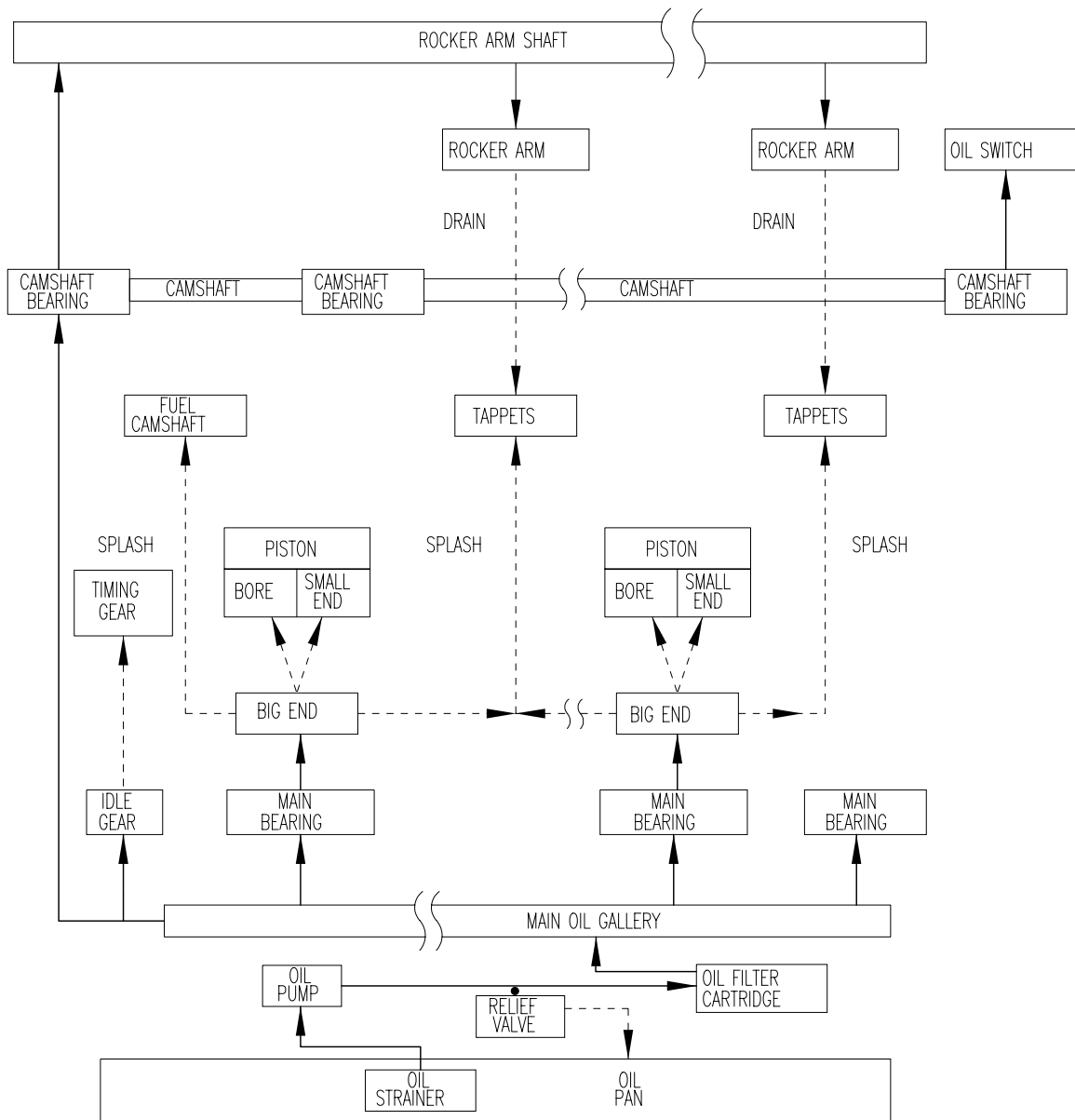

Figure 1-4. Lubrication System

1.16.3. Cooling System. The cooling system (Figure 1-5) consists of a radiator, centrifugal water pump, suction fan and a thermostat. The water is cooled through the radiator core and the fan, which is set behind the radiator, forcing cool air through the radiator core to improve cooling. The water pump forces the cooled water into the engine block and draws out the hot water. When the thermostat is open (at approximately 160°F (71.11°C)), water leaving the engine block goes directly to the radiator. However, when the thermostat closes, the water bypasses the radiator and moves directly to the water pump. The radiator cap sustains the internal pressure of the cooling system at 13 psi (89.63 kPa).

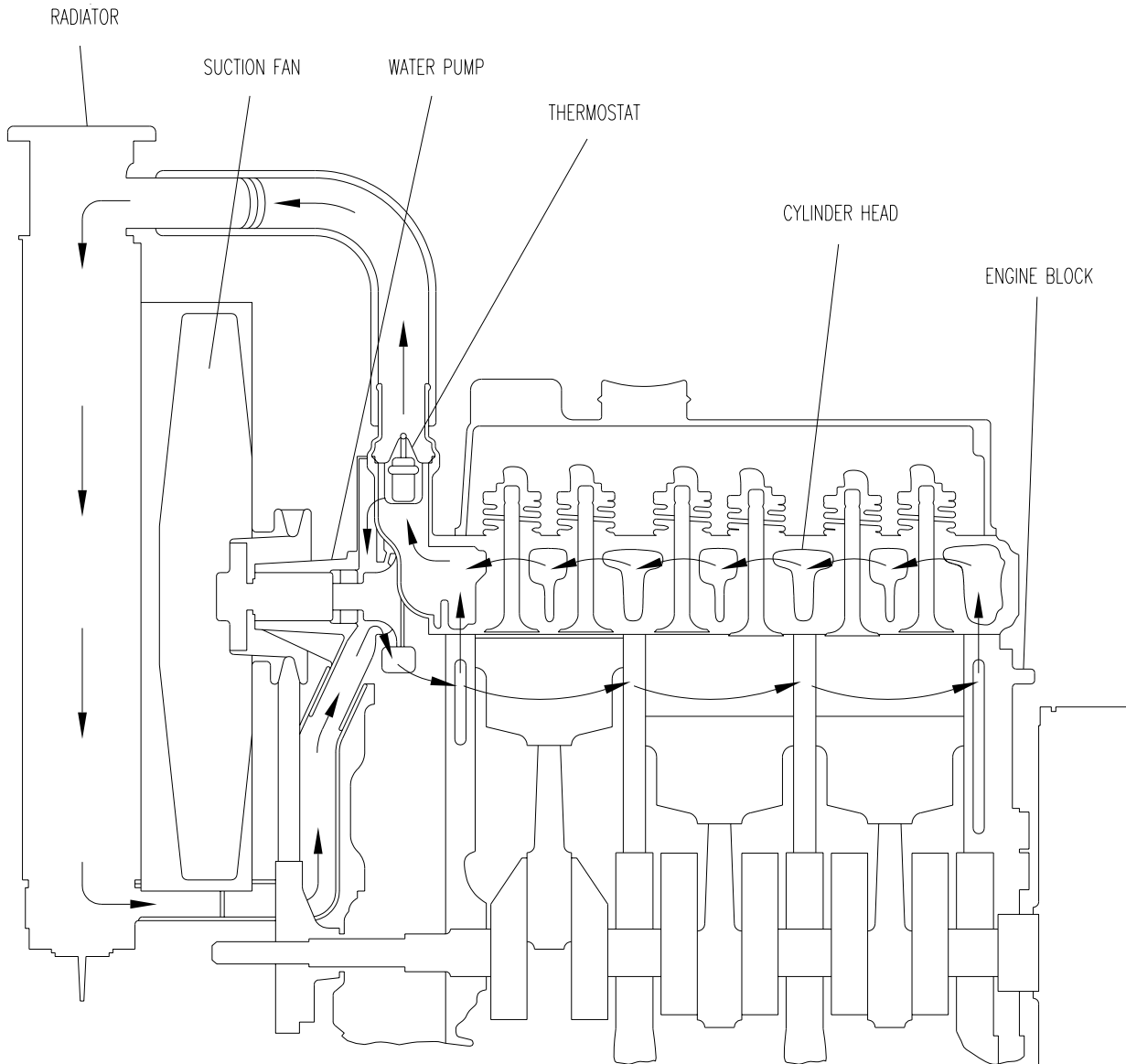
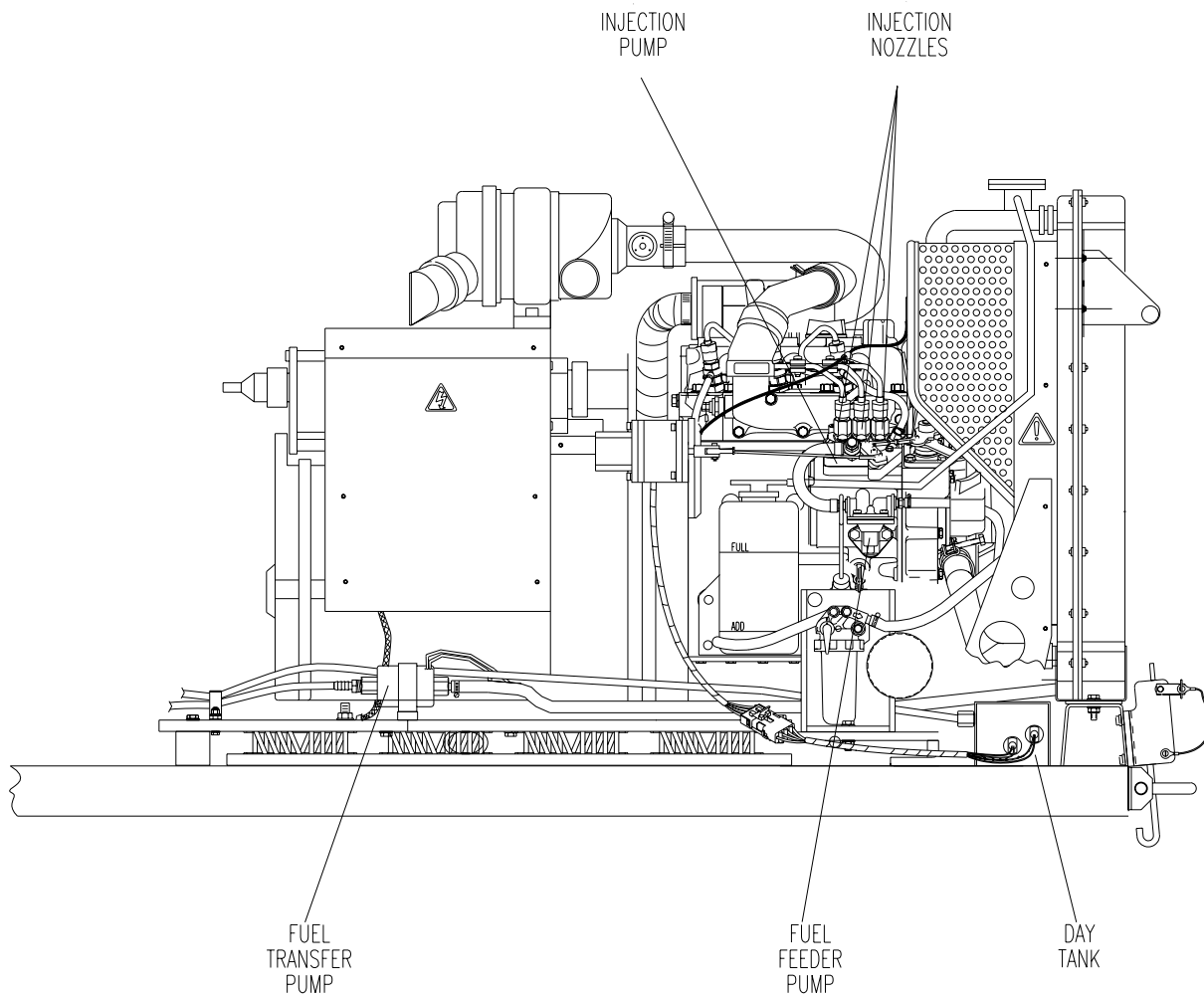

Figure 1-5. Cooling System

1.16.4. Fuel System. The fuel system (Figure 1-6) consists of a fuel transfer pump, small fuel reservoir (day tank), a fuel filter, a fuel feeder pump, and injection pump, and three injection nozzles. The fuel transfer pump draws fuel from the fuel tank of the host vehicle and feeds it to the day tank. The day tank is used to keep a small amount of fuel in the system so that it never runs dry, which would require priming the system each time it was started. The fuel filter receives the vehicle fuel from the day tank, and removes impurities such as dirt and water. The fuel feeder pump draws fuel from the filter and feeds it to the injection pump. The injection pump pressurizes the fuel to the opening pressure of the injection nozzles (between 1991 to 2062psi (13.72 to 14.22 KPa) from which it is injected into the combustion chamber. The injection pump and the injection nozzles use the engine fuel as a lubricant. Therefore, it is extremely important for the filter to remove dirt from the fuel and water accumulated in the tank. The injection nozzles are throttle type. Fuel pressurized by the injection pump pushes the nozzle's needle valve up allowing the fuel to enter the combustion chamber. Excessive fuel flow passes from the nozzle holder through a banjo fitting and returns to the fuel tank through a fuel overflow pipe. A governor controls the amount of fuel fed into the engine throughout the entire speed range, preventing the engine from changing its speed with variations in the load.



(MEP-903C, WIN-T)

Figure 1-6. Fuel System

1.16.5. Intake/Exhaust System. The engine's exhaust system (Figure 1-7) consists of an air filter, air intake pipe, turbo charger, exhaust pipe, and muffler. Fresh air enters the air filter which filters out dust and fine particles, and enters the turbo charger through the air intake pipe. The turbo charger then forces the fresh air into the cylinders, increasing engine power. Exhaust leaving the cylinders enters and powers the turbocharger, and then is channeled through the exhaust pipe and exits the system through the muffler, then the tail pipe.

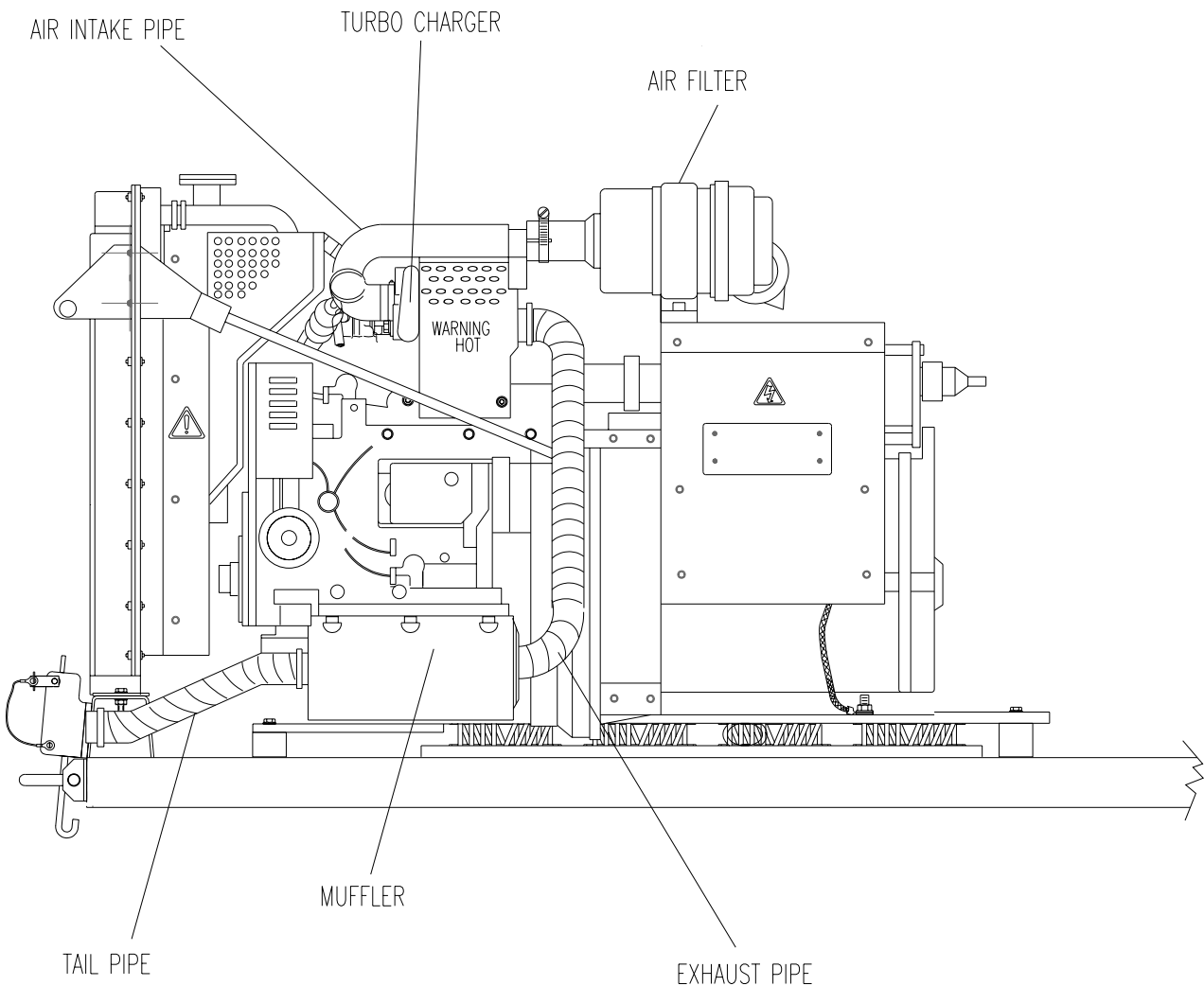

(MEP-903C, WIN-T)

Figure 1-7. Intake/Exhaust System

1.16.6. Electrical System. The engine's electrical system (Figure 1-8) consists of a starter system (including an electromagnetic drive type starter and glow plugs) and a charging system (including the AC alternator and regulator). The PREHEAT/START switch on the APU controller starts the engine. In the PREHEAT position, current from the vehicle battery is supplied to the glow plugs in each combustion chamber ensuring easy start-up. In the START position, current is supplied to the starter. The alternator is an 8-8 rotating magnet AC generator. The regulator performs rectification and voltage regulation. It converts alternator AC output to DC which flows through the power consuming circuits. DC is also fed back to the vehicle to charge the vehicle battery when the vehicle engine is not running. If the DC voltage is excessive, the DC current is cut off from the charging circuit to prevent overcharging.

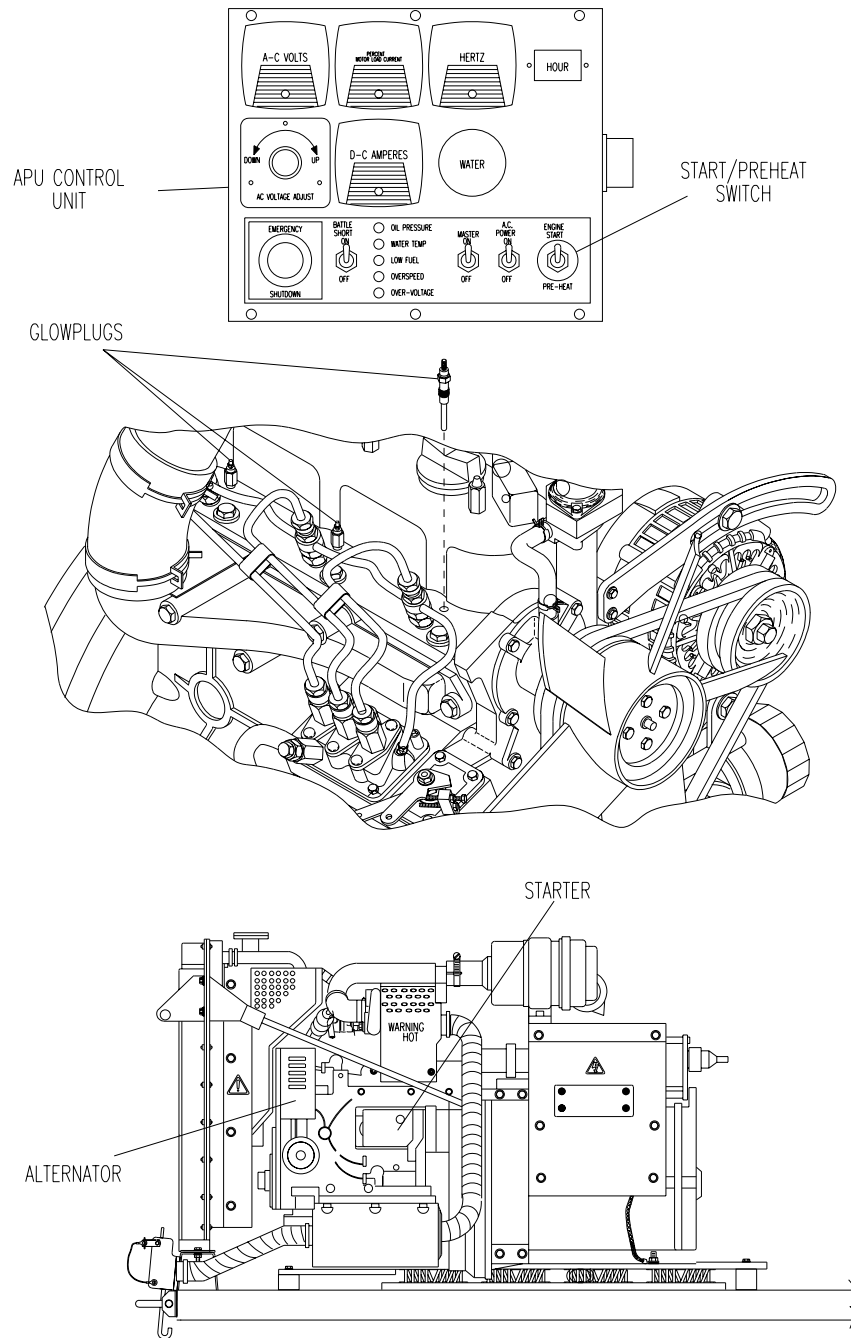

Figure 1-8. Electrical System

1.17. GENERATOR OPERATION.

1.17.1. Generator Circuit. The AC generator is a self-excited, single-bearing, brushless, drip-proof, two pole generator which outputs 120/240 VAC at 60 Hz when driven at 3600 rpm. It consists of an excitation system (including exciter stator, exciter rotor, and main rectifier assembly), and a generator system (including main stator and main rotor).

1.17.2. Main Stator and Automatic Voltage Regulator (AVR) Interface. The main stator provides power for excitation of the exciter field through the AVR (the controlling device governing the level of excitation provided to the exciter field) (Figure 1-9). The AVR responds to a voltage sensing signal derived from the main stator winding. By controlling the low power of the exciter field, control of the high power requirement of the main field is achieved through the rectified output of the exciter armature.

1.17.3. AVR and Diesel Engine Interface. The AVR detects engine speed and provides voltage fall off with speed, below a pre-selected speed (Hz). This prevents over-excitation at low engine speeds and softens the effect of load switching to relieve the burden on the engine.

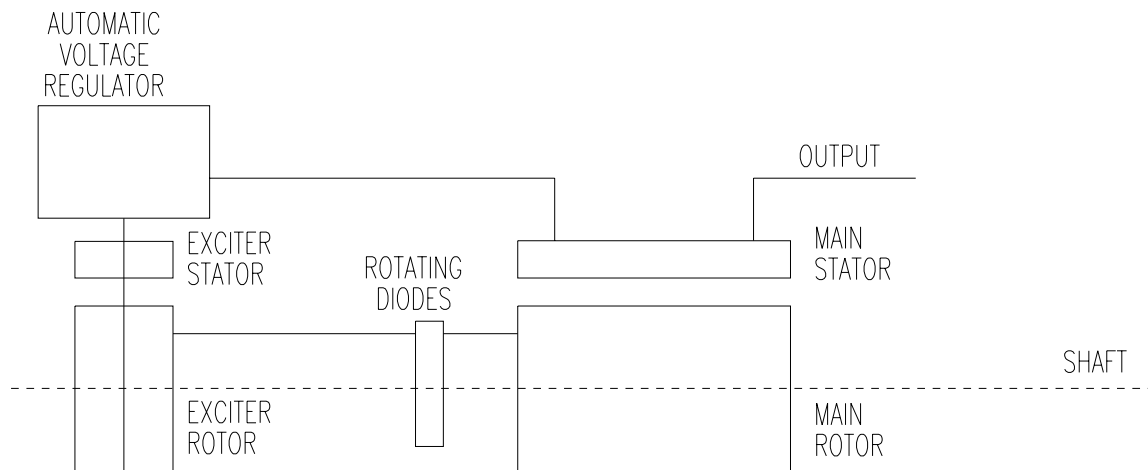

Figure 1-9. Main Stator and AVR Interface

1.18. CONTROL OPERATION.

1.18.1 Engine Speed Control System. A magnetic speed sensor (Figure 1-10) is installed on the engine block facing the teeth of the flywheel. As the flywheel rotates, it creates a magnetic field in the sensor. The frequency of the magnetic field varies with engine speed and is fed to the speed control box. If the signal indicates that the engine is varying from the specified 3600 rpm, the control box senses the incorrect frequency and sends a 24 VDC signal to an actuator/solenoid. The solenoid operates an actuator linkage which is connected through a pivot arm to a stud on the engine governor. Movement of the linkage rotates the governor arm which adjusts engine speed. When the sensor signals that correct engine speed is achieved, the control box cuts off its signal to the actuator/solenoid.

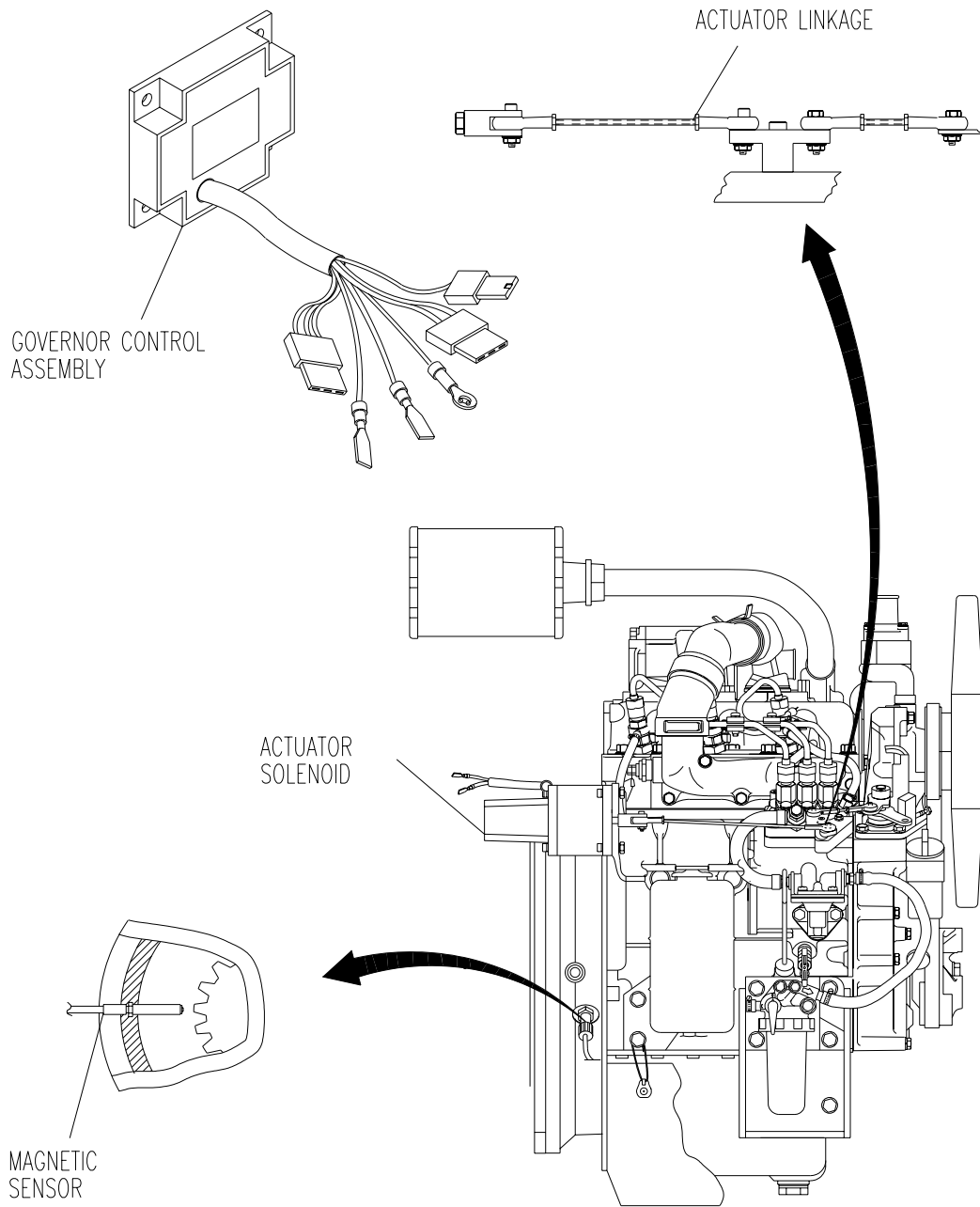
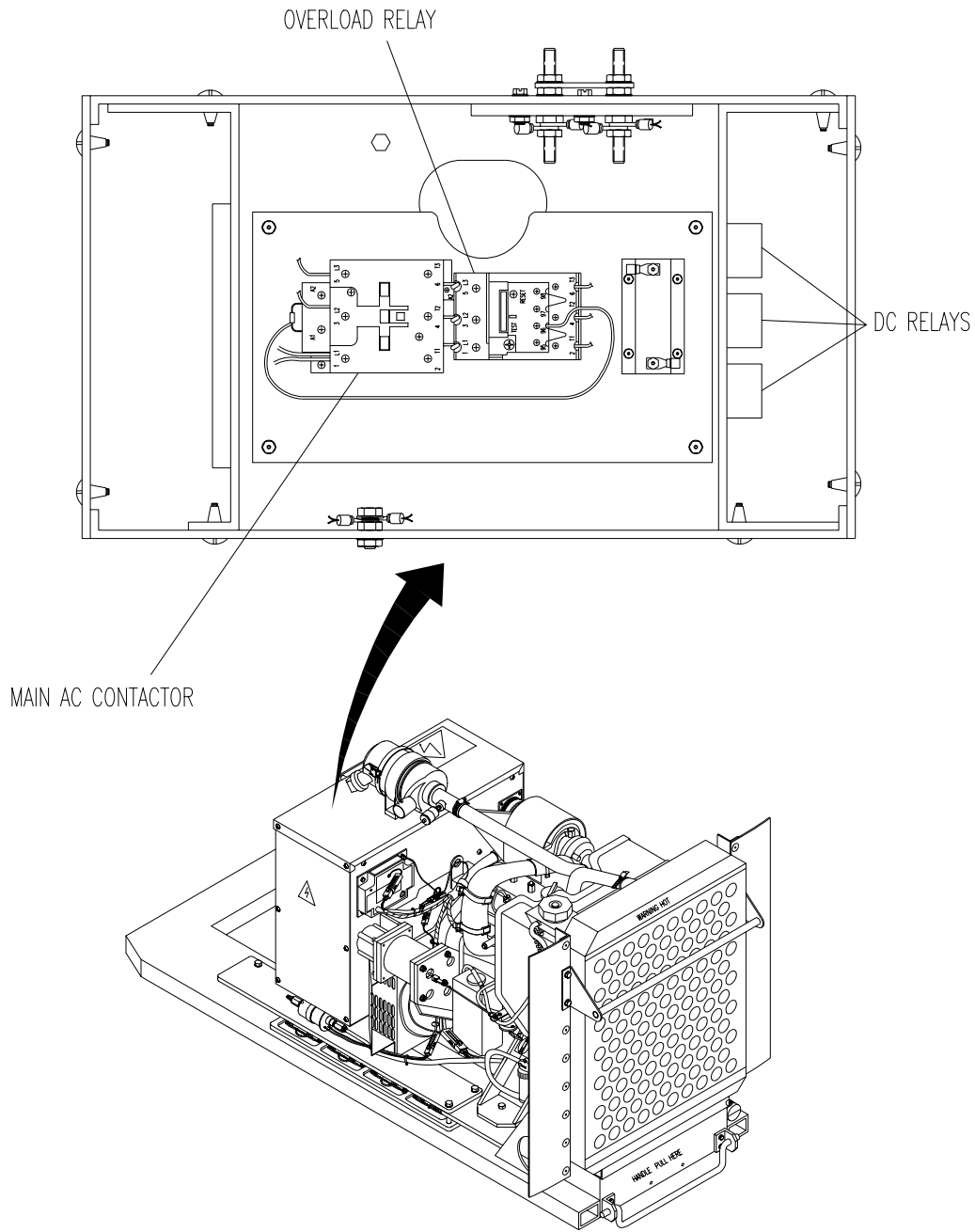

Figure 1-10. Engine Speed Control System

1.18.2. Current Control. The DC relays cut off the DC control circuits to stop the engine under conditions of low fuel, over-speed, or over-voltages. These conditions are indicated by illumination of fault indicator lights on the control box. An overload relay opens the main AC contactor cutting generator output under overload conditions. A reset button is on the relay the control circuit and allows the main AC contactor to operate after the overload is removed. The main AC contactor is activated by means of the AC POWER ON-OFF switch on the APU controller.



(MEP-903C, WIN-T)

Figure 1-11. Current Control

THIS PAGE INTENTIONALLY LEFT BLANK

CHAPTER 2
OPERATING INSTRUCTIONS

		Page
Section I	Description and Use of Operator Controls and Indicators	2-1
	2.1. APU Control Unit	2-1
Section II	Operator's Preventive Maintenance Checks and Services (PMCS).....	2-4
	2.2. Introduction to Operator PMCS Table.....	2-4
Section III	Operation Under Usual Conditions.....	2-12
	2.3. Assembly and Preparation for Use	2-12
	2.4. Preoperational Checks	2-12
	2.5. Operating Procedures.....	2-12
	2.6. Shut-Down	2-13
Section IV	Operation Under Unusual Conditions.....	2-14
	2.7. Operation in Arctic Climate	2-14
	2.8. Operation in Desert Climate.....	2-14
	2.9. Operation in Tropical Climate	2-15
	2.10. Operation in Salt Air or Sea Spray.....	2-15
	2.11. Nuclear, Biological, and Chemical (NBC) Decontamination Procedures .	2-15

NOTE

Refer to "Table 1-1. Differences Between Models." for differences between MEP-903A, MEP-903B and MEP-903C, which may not be depicted in the TM illustrations.

Section I. DESCRIPTION AND USE OF OPERATOR CONTROLS AND INDICATORS

2.1. APU CONTROL UNIT.

This section describes operator controls and indicators for the APU. All controls and indicators for the APU are located on the front panel of the control unit (Figure 2-1). Function or use of the controls and indicators is contained in Table 2-1.

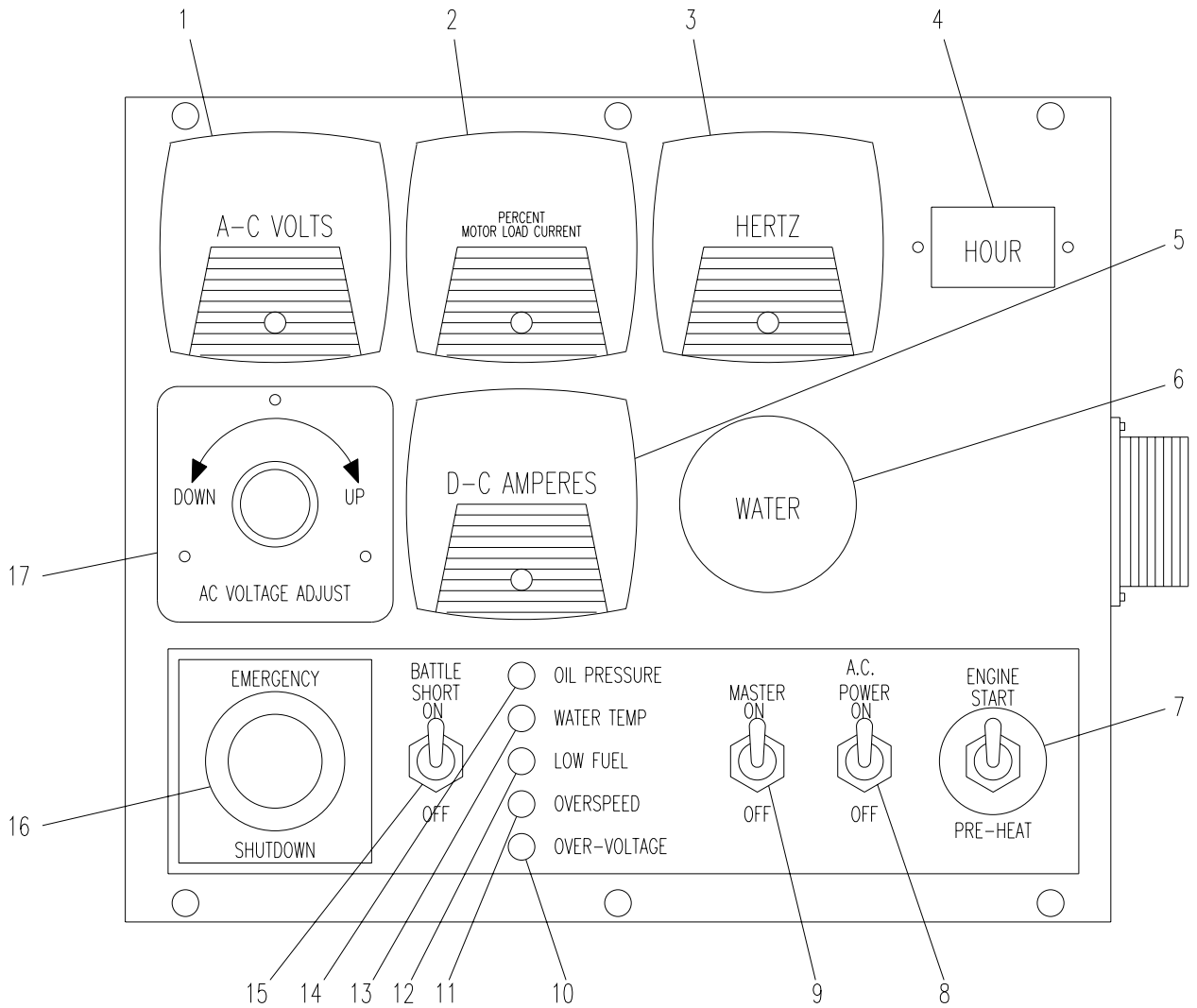

Figure 2-1. APU Control Unit Front Panel

Table 2-1. APU Control Unit Controls and Indicators

Key	Name	Type	Function
1	A-C VOLTS	AC voltmeter	Indicates APU output voltages; normal output is 120 V line-to-neutral or 240 V line-to-line.
2	PERCENT MOTOR LOAD CURRENT	AC ammeter	Indicates APU output current in 5% increments of APU rated output of 52.1 amps.
3	HERTZ	Frequency meter	Indicates APU output frequency in 0.2 Hz (0.1 Hz – JTACS) increments; normal output is 60 Hz.
4	HOUR	Hour meter	Indicates APU operating time in hours and tenths of hours.
5	D-C AMPERES	DC ammeter	Indicates DC current flow to and from system batteries in 1.0 amp increments; when batteries are fully charged, indication is near 0. A high reading indicates low charge.
6	WATER	Dial indicator gauge	Indicates water temperature in degrees fahrenheit (°F); normal operating temperature is from 170°F to 200°F (93°C to 97°C).
7	ENGINE START/ PRE-HEAT	3-position spring-loaded switch	Up position (ENGINE START) energizes APU starter; middle position is normal operating setting; down position (PRE-HEAT) preheats engine glow plugs prior to starting.
8	A.C. POWER	Toggle switch	In ON position, provides output power from APU.
9	MASTER	Toggle switch	In ON position, supplies DC power to all control circuits.
10	OVER-VOLTAGE	24 VDC light (red)	When lit, indicates over-voltage fault.
11	OVERSPEED	24 VDC light (red)	When lit, indicates engine over-speed fault.
12	LOW FUEL	24 VDC light (red)	When lit, indicates low fuel fault.
13	WATER TEMP	24 VDC light (red)	When lit, indicates engine high coolant temperature fault.
14	OIL PRESSURE	24 VDC light (red)	When lit, indicates low engine oil pressure fault.
15	BATTLE SHORT	Toggle switch	Permits emergency operation by bypassing protective device circuits, except overload circuit, and locks out starter circuit.
16	EMERGENCY SHUTDOWN	Pushbutton switch	When depressed, interrupts battery voltage to control circuits causing APU to shut down.
17	AC VOLTAGE ADJUST	Rheostat	Allows adjustment of APU output voltage.

Section II. OPERATOR PREVENTIVE MAINTENANCE CHECKS AND SERVICES (PMCS)

2.2. INTRODUCTION TO OPERATOR PMCS TABLE.

2.2.1. General. Table 2-2 (PMCS table) has been provided so you can keep your equipment in good operating condition and ready for its primary mission.

2.2.2. PMCS Procedures. The PMCS table is divided into five columns. Each column is explained in the following paragraphs.

2.2.2.1 Item No. Column. Numbers in this column are for reference. When completing DA Form 2404 (Equipment Inspection and Maintenance Worksheet) or DD Form 5988E (included in the Unit Level Logistics System (ULLS)), include the item number for the check/service indicating a fault. Item numbers also appear in the order that you must perform checks and services for the intervals listed.

2.2.2.2 Interval Column. This column informs you when you must perform the procedure in the procedure column. "BEFORE" procedures must be completed before you operate the equipment for its intended mission. "DURING" procedures must be completed during the time you are operating the equipment for its intended mission. "AFTER" procedures must be completed immediately after you have operated the equipment. Perform "WEEKLY" procedures at the listed interval.

2.2.2.3 Location, Item to Check/Service Column. This column lists the location and the item to be checked or serviced.

2.2.2.4 Procedure Column. This column gives the procedure for checking or servicing the item listed in the location, item to check/service column. You must perform the procedure to know if the generator set 10 kW is ready or available for its intended mission or operation. You must perform the procedure at the time stated in the interval column.

2.2.2.5 Not Mission Capable If: Column. Information in this column informs you of faults that will keep your equipment from being capable of performing its primary mission. If you make checks or services that show faults listed in this column, do not operate the equipment.

2.2.3. Other Table Entries. Be sure to observe all special information and notes that appear in your table.

2.2.4. Special Instructions. Preventive maintenance is not limited to performing the checks and services listed in the PMCS table. Covering unused receptacles, stowing unused accessories, and other routine procedures such as equipment inventory, cleaning components, and touch-up painting are not listed in the table. These are things you should do any time you see that they need to be done. If a routine check is listed in the PMCS table, it is because experience has shown that problems may occur with this item. Take along the tools and cleaning cloths needed to perform the required checks and services. Use the information in the following paragraphs to help you identify problems at any time. Use the following information to help identify potential problems before and during checks and services.

WARNING

Dry cleaning solvent used to clean parts is potentially dangerous to personnel and property. Clean parts in a well-ventilated area. Avoid inhalation of solvent fumes. Wear goggles and rubber gloves to protect eyes and skin. Wash exposed skin thoroughly. Do not smoke or use near open flame or excessive heat. Failure to observe this warning can cause severe injury to personnel or DEATH.

CAUTION

Keep cleaning solvents, gasoline and lubricants away from rubber or soft plastic parts. They will deteriorate material.

- a. Keep it clean. Dirt, grease, and oil get in the way and may cover up a serious problem. Use dry cleaning solvent to clean metal surfaces.
- b. Use soap and water to clean rubber or plastic parts and material.
- c. Check all bolts, nuts, and screws to make sure they are not loose, missing, bent, or broken. Do not try to check them with a tool, but look for chipped paint, bare metal, or rust around bolt heads. If you find one loose, report it to the next higher level of maintenance.
- d. Inspect welds for loose or chipped paint, rust, or gaps where parts are welded together. If a broken weld is found, report it to the next higher level of maintenance.
- e. Inspect electrical wires, connectors, terminals, and receptacles for cracked or broken insulation, bare wires, and loose or broken connectors. Tighten loose connectors. Examine terminals and receptacles for serviceability. If deficiencies are found, report them to the next higher level of maintenance.
- f. Inspect hoses and fluid lines. Look for wear, damage, and leaks. Make sure that clamps and fittings are tight. Wet spots and stains around a fitting or connector can mean a leak. If a leak comes from a loose connector, or if something is broken or worn out, report it to the next higher level of maintenance.

2.2.5. Leakage Definitions. You must know how fluid leakage affects the status of your equipment. The following are definitions of the types/classes of leakage you need to know to be able to determine the status of your equipment. Learn and be familiar with them. When in doubt, notify your supervisor.

Leakage Class

Leakage Definition

Class I	Seepage of fluid (as indicated by wetness or discoloration) not great enough to form drops.
---------	---

Leakage
Class

Leakage Definition

Class II	Leakage of fluid great enough to form drops, but not enough to cause drops to drip from the item being checked/inspected.
Class III	Leakage of fluid great enough to form drops that drip from the item being checked/inspected.

2.2.6. Operation of Generator Set with Minor Leaks.

CAUTION

Equipment operation is allowable with minor leakage (Class I or II) of any fluid except fuel. Fluid capacity must be considered before deciding to continue operation of the equipment with minor leaks. When operating with Class I or II leaks, fluid level must be checked more often than required by the PMCS table. Parts without fluid will stop working and/or cause equipment damage.

- a. Consider the equipment's capacity for the fluid that is leaking. If the capacity is small, the fluid level may soon become too low for continued operation. If in doubt, notify your supervisor.
- b. Check the fluid level more often than required in the PMCS table. Add fluid as needed.

2.2.7. Corrosion Prevention and Control (CPC). CPC of Army material is of continuing concern. It is important that any corrosion problems with the equipment be reported so that the problem can be corrected and improvements can be made to prevent the problem in future items. While corrosion is typically associated with rusting of metals, it can also include deterioration of other materials, such as rubber and plastic. Unusual cracking, softening, swelling, or breaking of these materials may be a corrosion problem. If a corrosion problem is identified, it can be reported using Standard Form 368, Product Quality Deficiency Report. Use of key words such as "corrosion," "rust," "deterioration," or "cracking" will ensure that the information is identified as a CPC problem. The form should be submitted to the address specified in DA PAM 738-750.

2.2.8. Order in Which PMCS Will be Done. Figure 2-2 shows the order in which you are to perform your PMCS. The number callouts on Figure 2-2 correspond to the numbers in the Item No. column of Table 2-2, for "Before" PMCS.

2.2.9. Warnings, Cautions, and Notes. Always observe WARNINGS, CAUTIONS, and NOTES appearing in your PMCS table. Warnings and cautions appear before applicable procedures. You must observe WARNINGS to prevent serious injury or death to yourself and others. You must observe CAUTIONS to prevent your equipment from being damaged. You must observe NOTES to ensure procedures are performed properly.

Table 2-2. Operator Preventative Maintenance Checks and Services (PMCS) for Auxiliary Power Unit, 10 kW, 120/240 VAC, 60 Hz

Item No.	Interval	Location	Procedure	Not Mission Capable If:
		Item to Check/Service		
			<p><u>WARNING</u></p> <p>Hot coolant is under pressure. Do not remove radiator cap when engine is hot. Allow engine to cool completely before removing radiator cap. Once cooling has occurred, loosen cap slightly to relieve any excess pressure before removing the cap completely. Failure to observe this warning could result in burns or injury to personnel.</p> <p><u>CAUTION</u></p> <p>Be sure to close radiator cap securely. If cap is loose or improperly closed, coolant may leak out and the engine could overheat</p>	
1	Before	Generator Set	<p>Check for loose, broken or missing hardware.</p> <p>Check for fluid leaks.</p> <p>Check for any loose wires or broken meters.</p>	Level III fluid Leak exists.
	Before/ During	Ground Cable and Connection	Inspect ground rod and cable for loose connections, breaks, damage and corrosion. Check for paint.	Cable is missing or damaged or components are not free of paint.
2	Before	Engine radiator	Check coolant level. Coolant level should be halfway between "FULL" and "LOW" marks on radiator overflow tank; add coolant if needed (para 3.8.).	Coolant level is well below radiator port.
3	Before	Radiator hose	Check for leaks.	Class III leak exists (para 2.2.5, 4.7.4.).
4	Before	Radiator overflow tank	Check coolant level. Coolant level should be halfway between "FULL" and "LOW" marks.	(Figure 2-2)

ARMY TM 9-6115-670-14&P

Table 2-2. Operator Preventive Maintenance Checks and Services (PMCS) for Auxiliary Power Unit, 10 kW, 120/240 VAC, 60 Hz – Continued

Item No.	Interval	Location		Procedure	Not Mission Capable If:
		Item to Check/Service			
				<u>CAUTION</u>	
				When using an oil of different viscosity from the previous one, drain old oil. Never mix two different types of oil.	
5	Before	Engine crankcase		Check oil level. Replenish oil if needed (para 3.6.).	Oil level is below lower notch in dip stick.
6	During	Generator Set		Check for fluid and exhaust leaks.	Exhaust or Level III fluid leak exists (para 2.2.5).
7	During	Diesel engine		Check for failure of engine to start, sudden stopping, erratic performance, knocking, excessive smoke in exhaust, engine overheating. Check/ensure fuel shut-off valve is in open position (O).	Erratic or Level III fluid leak exists (para 2.2.5).
8	Before	(Air Filter)		(SICPS, JTACS, and WIN-T). Check air filter for dirt (para 4.45.). Ensure lid is secured properly. Check filter air flow restriction indicator. If it indicates restriction (red) or remains red after depressing button on indicator, replace filter.	(Fig 2-2) (WIN-T)
9	After	Diesel engine		Check for excessive fuel usage at vehicle fuel gauge. Engine should not consume more than 1.31 gallons (4.96 liters) per hour when operating at 3600 rpm and at rated load.	Engine uses too much fuel.
10	Before	Fuel lines		Check for leaks.	Any fuel leak exists (Class I, II, or III) (para 2.2.5, 4.7.4).
11	During	Fuel shut-off valve		Check that it is in an open (O) position.	
12	During	Control Unit		Check for proper readings on AC and DC indicators and frequency meter. Check that all indicator lamps are out. Check that hour meter has changed since last operation. Check WATER gauge for proper water temperature reading.	Improper DC inputs, AC outputs, AC frequency indications. WATER gauge reads high WATER temperature.

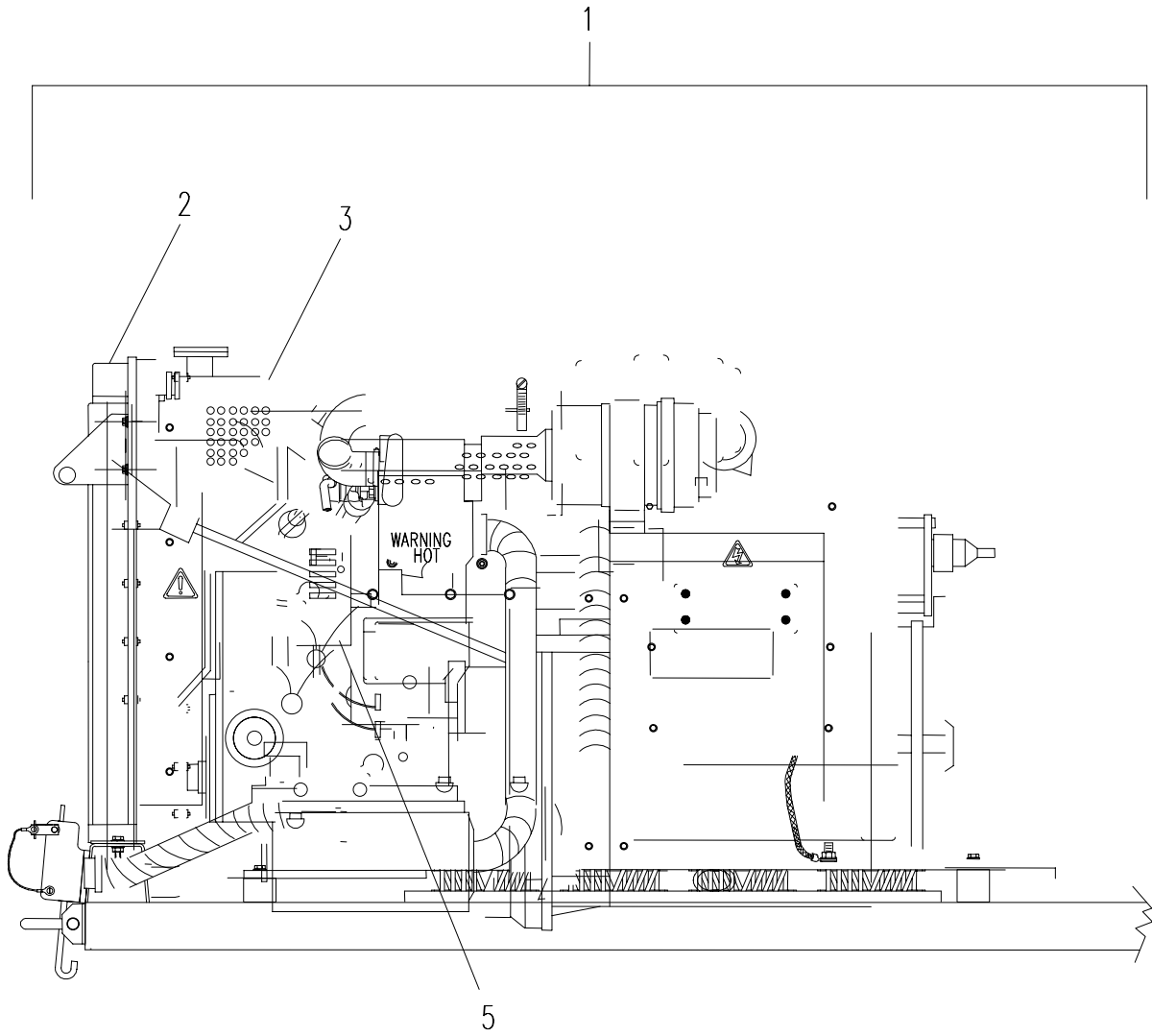

(MEP-903C, WIN-T)

Figure 2-2. Operator PMCS Routing Diagram (Sheet 1 of 3)

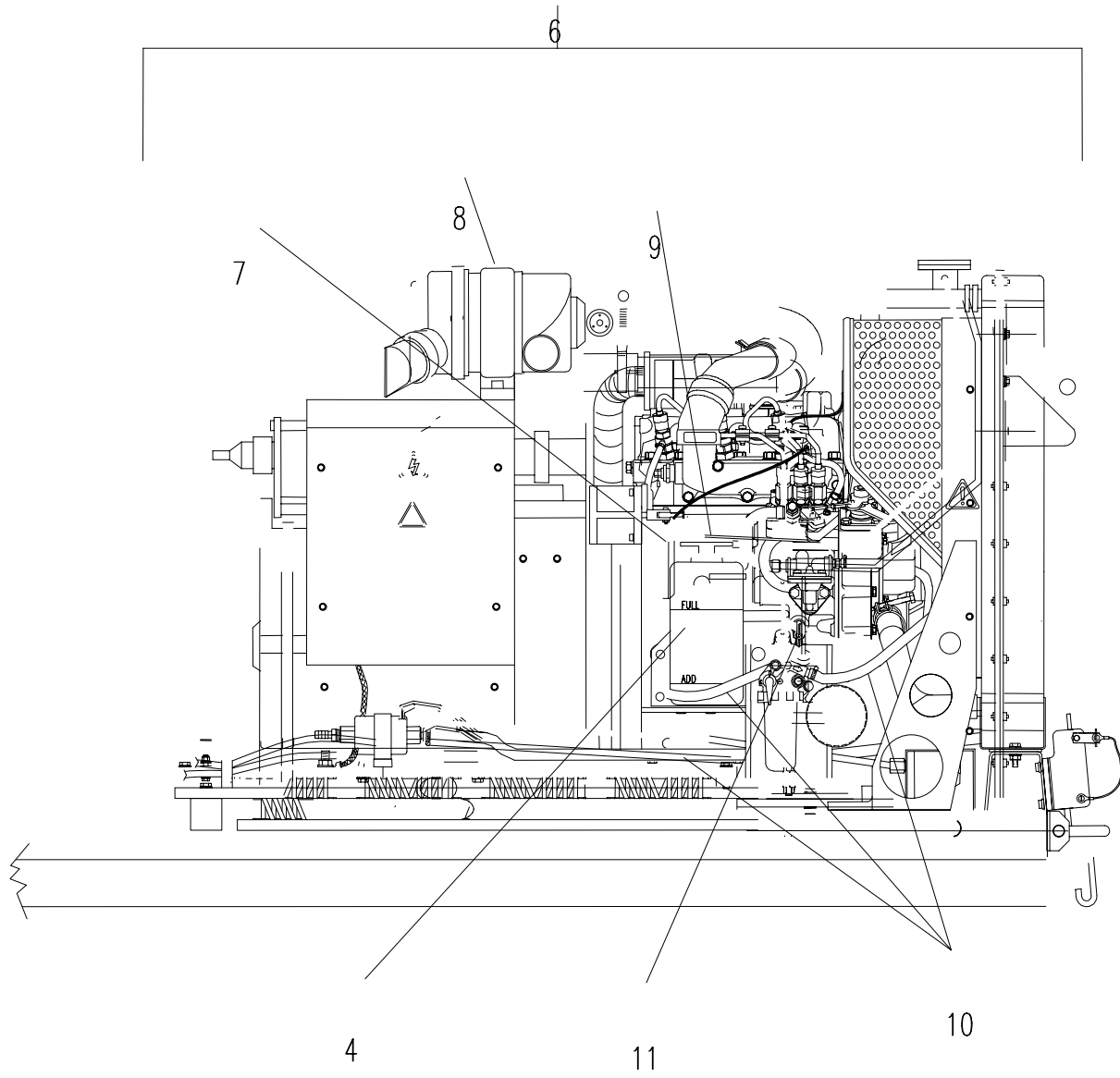

(MEP-903C, WIN-T)

Figure 2-2. Operator PMCS Routing Diagram (Sheet 2 of 3)

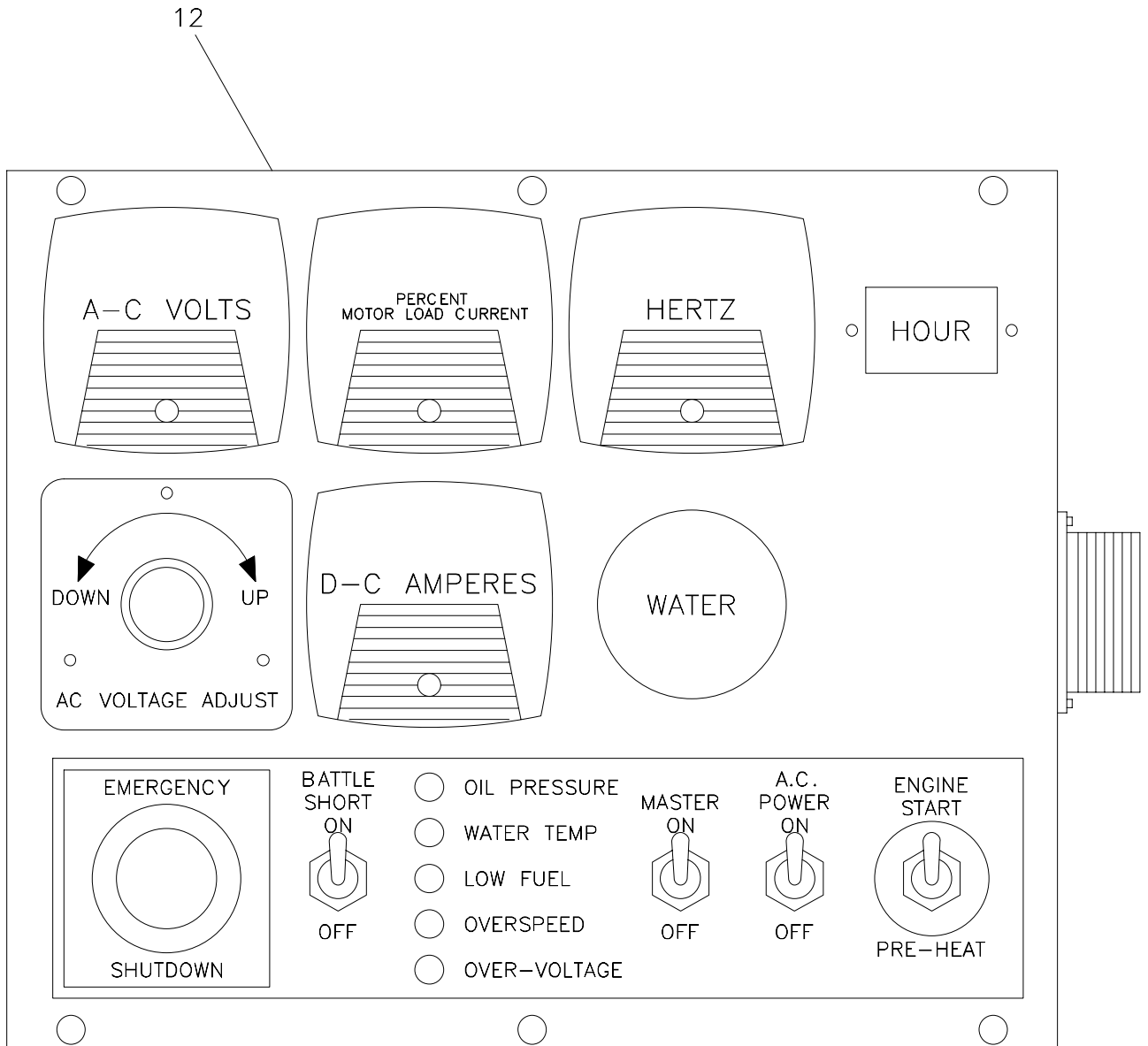

Figure 2-2. Operator PMCS Routing Diagram (Sheet 3 of 3)

Section III. OPERATION UNDER USUAL CONDITIONS

2.3. ASSEMBLY AND PREPARATION FOR USE.

There are no operator's assembly or preparation for use instructions for the APU.

2.4. PREOPERATIONAL CHECKS.

2.4.1. Inspection. Perform a complete visual inspection of the APU for evidence of damage. Check the air filter and exhaust opening for obstructions. Perform Operator's PMCS.

2.4.2. Initial Switch Positions. Determine that the following switches on the control unit are positioned as follows:

Table 2-3. Control Unit Start-Up Switch Positions

Switch	Position
MASTER ON-OFF Switch	OFF
AC Power ON-OFF Switch	OFF
EMERGENCY SHUTDOWN Button	Pulled out
BATTLE SHORT ON-OFF Switch	OFF

2.4.3. Jumper Bar Installation. Refer to FO-1 (SICPS/WIN-T) or FO-7 (JTACS) for installation of jumper bars for low voltage (120 VAC) and high voltage (240 VAC) power connections.

NOTES

For low voltage connection, connect power cables to L1 and L2 load terminals. 240 VAC power connection not available in low voltage connection.

For high voltage connection, connect power cables to L1 and L2 load terminals. 120 VAC power connection available for limited time by connecting power cables to L1 or L2 and L0 (L1-L0, L2-L0) in high voltage connection.

2.5. OPERATING PROCEDURES.

WARNING

Wear approved hearing protection while operating the 10 kW APU. Failure to heed this warning can cause severe injury to personnel.

WARNING

Never attempt to start the APU if it is not properly grounded. Refer to the system technical manual for proper grounding procedures. Failure to observe this warning may result in serious injury or DEATH by electrocution.

Proceed as follows:

- a. Check that the ground strap is fastened securely to the frame assembly. If it is not, notify the next higher level of maintenance.
- b. Refer to the system technical manual and ensure APU power source is turned on.
- c. On APU control unit front panel, place MASTER ON-OFF switch to ON position. OIL PRESSURE indicator will go out when APU engine starts. LOW FUEL indicator will illuminate and go out once APU fuel reservoir becomes full.
- d. Place ENGINE START-PREHEAT switch in PREHEAT position and hold for 30 seconds.
- e. Place ENGINE START-PREHEAT switch in START position. When APU engine starts, release switch. All fault indicators on APU control unit front panel should be out.

CAUTION

If any of the indicator lights illuminate, stop the APU and correct the indicated fault before proceeding with operations.

- f. Check that DC AMP ammeter on APU control unit front panel is reading positive current flow.

CAUTION

Do not crank engine in excess of 15 seconds. Allow starter assembly to cool at least 15 seconds between cranking.

- g. When WATER TEMPERATURE gauge on APU control panel reaches 140°F (60°C), place AC POWER ON-OFF switch in ON position.
- h. Observe all APU control unit front panel instruments for normal readings.

2.6. SHUT-DOWN.

2.6.1. Normal Shut Down. Proceed as follows:

- a. Place the AC POWER ON-OFF switch in the OFF position.
- b. Allow the APU to operate approximately three minutes with no load applied.
- c. Place the MASTER ON-OFF switch in the OFF position.

2.6.2. Emergency Shut Down. Press in the EMERGENCY SHUTDOWN switch. The APU will shut down immediately.

NOTES

Before restarting the APU, ensure that the EMERGENCY SHUTDOWN switch is pulled out.

The BATTLE SHORT switch should be activated ONLY in emergency situations. Activating the switch will override all APU safety features except the overload condition safety feature.

Section IV. OPERATION UNDER UNUSUAL CONDITIONS

WARNING

Never place ends of electrical cables or connectors on the ground. Dirt and moisture can lead to a faulty electrical connection and create a shock or fire hazard.

2.7. OPERATION IN ARCTIC CLIMATE.

Insufficient antifreeze in coolant mix will allow coolant to freeze and cause engine damage. Ensure that antifreeze, lubricating oil, and diesel fuel are selected for arctic weather climate. When operating in arctic climate, observe the following:

CAUTION

Never use starting agents on engine. Failure to heed this caution could result in damage to engine.

- a. If outside temperatures are below 32°F (0°C), hold ENGINE START/PREHEAT switch in PREHEAT position for 90 seconds before starting.
- b. Ensure that coolant mix has sufficient antifreeze. Maximum protection is obtained by a mixture of 60% by volume of ethylene glycol to clean water (4.8 pints (0.473 liter) of antifreeze per gallon (3.785 liters) of solution).
- c. Ensure that lubricating oil has proper viscosity for operation at arctic climate. At temperatures below 32°F (0°C), use SAE 10W or 10W-30.
- d. Use DF-A type diesel fuel when operating in arctic temperatures.

2.8. OPERATION IN DESERT CLIMATE.

The APU is subject to damage from dust and dirt in hot, dry climates. Observe the following precautions when operating the APU in desert climate:

- a. Check coolant level on a daily basis. Add coolant if necessary.
- b. Keep APU covered as much as possible.
- c. After a sand or dust storm, inspect APU for accumulation of sand or dust IMMEDIATELY and remove accumulated sand and dust.

2.9. OPERATION IN TROPICAL CLIMATE.

Extreme heat and humidity can cause moisture condensation and fungus growth, resulting in damage to equipment and over heating. Observe the following conditions when operating in a tropical climate:

- a. Check coolant level on a daily basis. Add coolant if necessary.
- b. Wipe moisture and fungus growth from APU with a clean, lint-free cloth.
- c. Check engine air filters on a weekly basis.

2.10. OPERATION IN SALT AIR OR SEA SPRAY.

Salt air or sea spray can cause serious damage from corrosion. Clean all APU surfaces with a clean, lint-free cloth dampened with fresh water.

2.11. NUCLEAR, BIOLOGICAL, AND CHEMICAL (NBC) DECONTAMINATION PROCEDURES.

Refer to FM 3-3, FM 3-4, and FM 3-5 for detailed decontamination procedures.

THIS PAGE INTENTIONALLY LEFT BLANK

CHAPTER 3

OPERATOR MAINTENANCE INSTRUCTIONS

		Page
Section I.	Lubrication Instructions	3-1
	3.1. Lubrication Instructions	3-1
Section II.	Operator Troubleshooting	3-1
	3.2. General	3-1
	3.3. Operator Troubleshooting Procedures	3-1
Section III.	Operator Maintenance Procedures	3-13
	3.4. APU Painting	3-13
	3.5. Oil Dipstick	3-14
	3.6. Engine Oil	3-16
	3.7. Radiator Cap	3-18
	3.8. Radiator	3-20

NOTE

Refer to "Table 1-1. Differences Between Models." for differences between MEP-903A, MEP-903B, and MEP-903C, which may not be depicted in the TM illustrations.

Section I. LUBRICATION INSTRUCTIONS

3.1. LUBRICATION INSTRUCTIONS.

Lubrication instructions are in Appendix G of this technical manual (TM). All lubrication instructions are mandatory.

Section II. OPERATOR TROUBLESHOOTING

3.2. GENERAL.

This section contains troubleshooting procedures to determine the probable cause of observed equipment malfunctions. Branching logic trees are provided to isolate the faulty component and offer corrective actions to eliminate the malfunction.

3.3. OPERATOR TROUBLESHOOTING PROCEDURES.

The following pages list common malfunctions that may occur during operation or maintenance of the APU, followed by a troubleshooting procedure. Refer to the symptom index to locate the troubleshooting procedure for the malfunction you observe. Each troubleshooting procedure consists of a branching logic tree. Perform the test or inspection, and the recommended corrective action in the order listed in the logic tree. If the malfunction is corrected by a specific corrective action, do not continue with any remaining steps. If the corrective actions do not correct the malfunction, notify the next higher level of maintenance.

SYMPTOM INDEX

Symptom	Page
1. Engine fails to crank	3-3
2. Engine turns over but fails to start	3-4
3. Engine starts, but stops when start-preheat switch is released	3-5
4. Engine stops suddenly	3-6
5. Engine runs erratically or misfires.....	3-6
6. Engine does not develop full power	3-6
7. Engine knocks	3-7
8. Black smoke in exhaust.....	3-8
9. Blue or white smoke in exhaust.....	3-8
10. Low oil pressure	3-9
11. Engine overheating.....	3-10
12. Engine coolant temperature too low	3-11
13. DC ammeter shows no charge when vehicle battery is low or discharged	3-11
14. DC ammeter shows excessive charging after prolonged APU operation	3-11
15. Excessive oil consumption	3-11
16. High oil pressure.....	3-11
17. Fuel mixed into lubricant oil	3-11
18. Coolant mixed into lubricant oil.....	3-11
19. AC voltmeter does not indicate voltage	3-11
20. AC voltmeter indicates voltage but frequency meter is off scale	3-11
21. AC voltage fluctuates.....	3-12
22. Frequency fluctuates	3-12
23. Main AC contactor will not close.....	3-12
24. Oil pressure fault indicator lights	3-12
25. Water temp fault indicator lights	3-12
26. Low fuel fault indicator lights	3-12
27. Overspeed fault indicator lights	3-12
28. Over-voltage fault indicator lights	3-12

1. ENGINE FAILS TO CRANK.

STEP 1. Check to see if proper starting procedures were performed.

- a. If proper starting procedures were not performed, perform proper starting procedures.
- b. If proper procedures were performed, proceed to step 2.

STEP 2. Check to see if generator 24V DC battery cables are connected tightly to generator and vehicle.

- a. If battery cables are not connected tightly to generator or vehicle, connect battery cables and tighten.
- b. If battery cables are tight, notify next higher level of maintenance.

2. ENGINE TURNS OVER BUT FAILS TO START.

STEP 1. Check to see if proper starting procedures were followed.

- a. If proper starting procedures were not followed, start APU per Para. 2-5.
- b. If proper starting procedures were followed, proceed to step 2.

STEP 2. Check for low or no vehicle fuel supply.

- a. If vehicle fuel tank is low, service vehicle fuel tank.
- b. If vehicle fuel tank has adequate amount of fuel, proceed to step 3.

STEP 3. Check for closed Selector valve on fuel filter.

- a. If fuel selector valve is closed, open fuel selector valve.
- b. If fuel selector valve is open, notify next higher level of maintenance.

3. ENGINE STARTS, BUT STOPS WHEN START-PREHEAT SWITCH IS RELEASED.

STEP 1. Check to see if START-PREHEAT SWITCH was held in the start position long enough.

- a. If START-PREHEAT SWITCH was not held in start position long enough, restart generator using procedures in this TM (Para. 2.5) or system TM by holding switch in start position longer.
- b. If START-PREHEAT SWITCH was held long enough, proceed to step 2.

STEP 2. Check for adequate fuel level in vehicle fuel tank.

- a. If vehicle fuel tank is low, service vehicle fuel tank.
- b. If vehicle fuel tank has adequate amount of fuel, proceed to step 3.

STEP 3. Check for clogged air filter. Inspect Air Flow Restriction Indicator and visually inspect air filter element.

- a. If the air filter is clogged or the filter element is dirty, SERVICE air filter.
- b. If the air filter is clean and not clogged, proceed to step 4.

STEP 4. Check for low oil level (Para. 3.6).

- a. If engine oil level is low, SERVICE engine oil (Para. 3.6).
- b. If engine oil level is between notches on the oil dipstick, notify next higher level of maintenance.

4. ENGINE STOPS SUDDENLY.

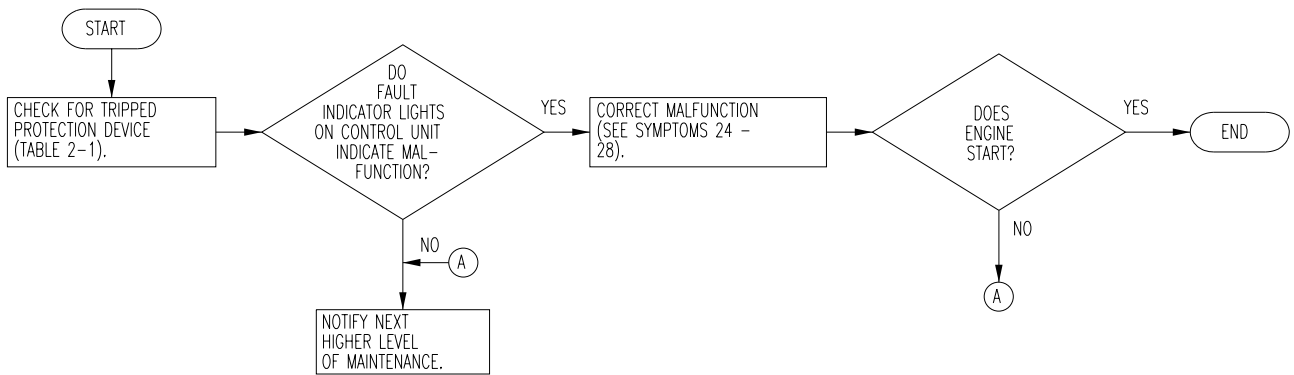

5. ENGINE RUNS ERRATICALLY OR MISFIRES.

Notify next higher level of maintenance.

6. ENGINE DOES NOT DEVELOP FULL POWER.

Notify next higher level of maintenance.

7. ENGINE KNOCKS.

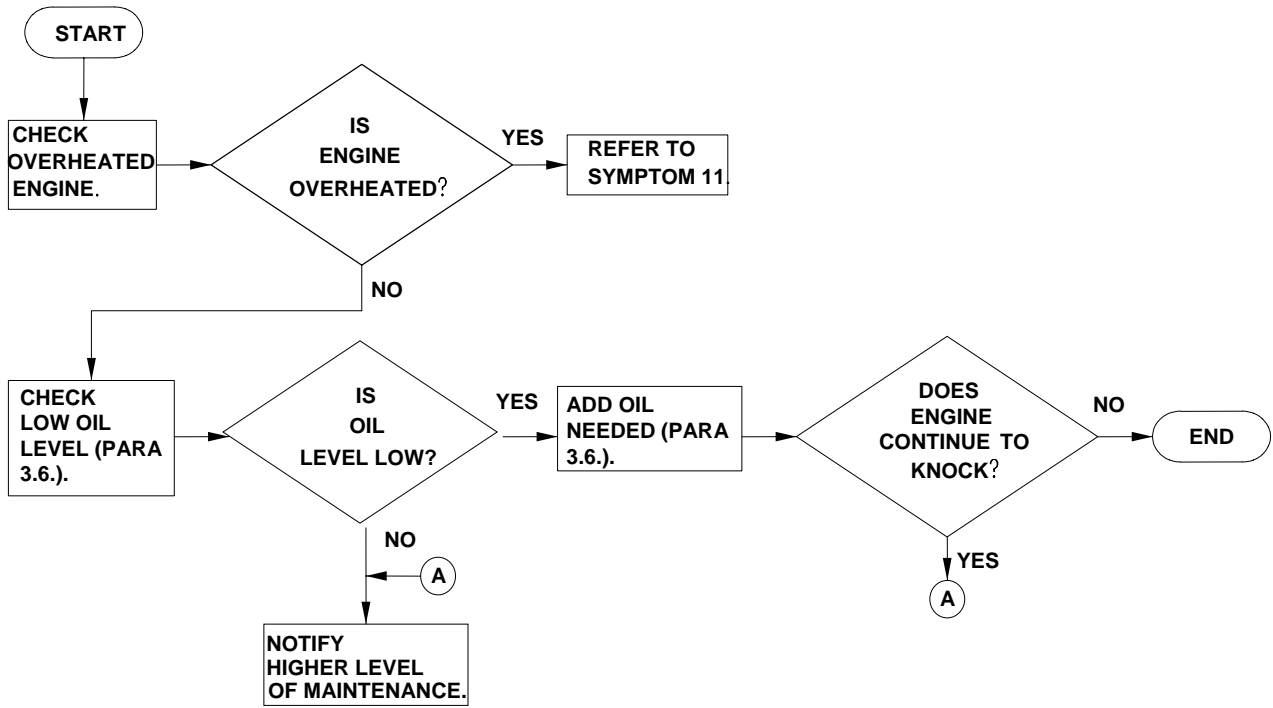

8. BLACK SMOKE IN EXHAUST.

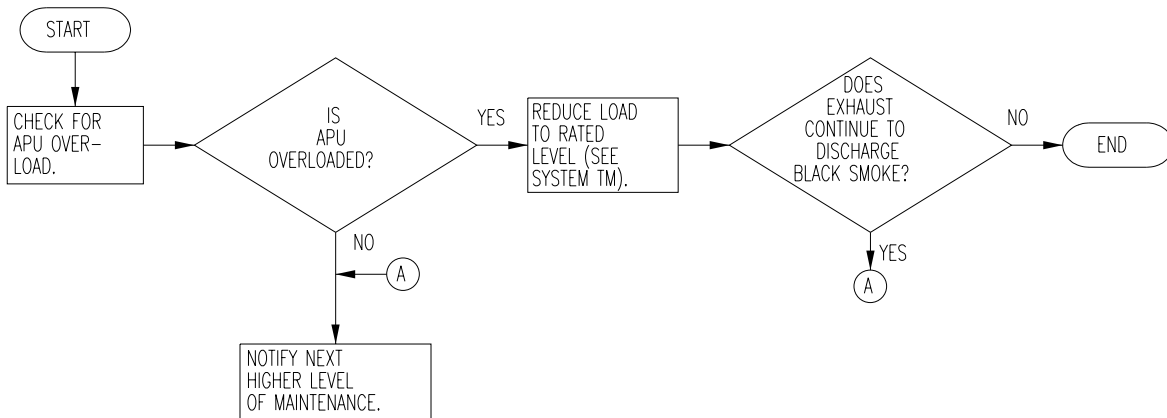

9. BLUE OR WHITE SMOKE IN EXHAUST.

Notify next higher level of maintenance.

10. LOW OIL PRESSURE.

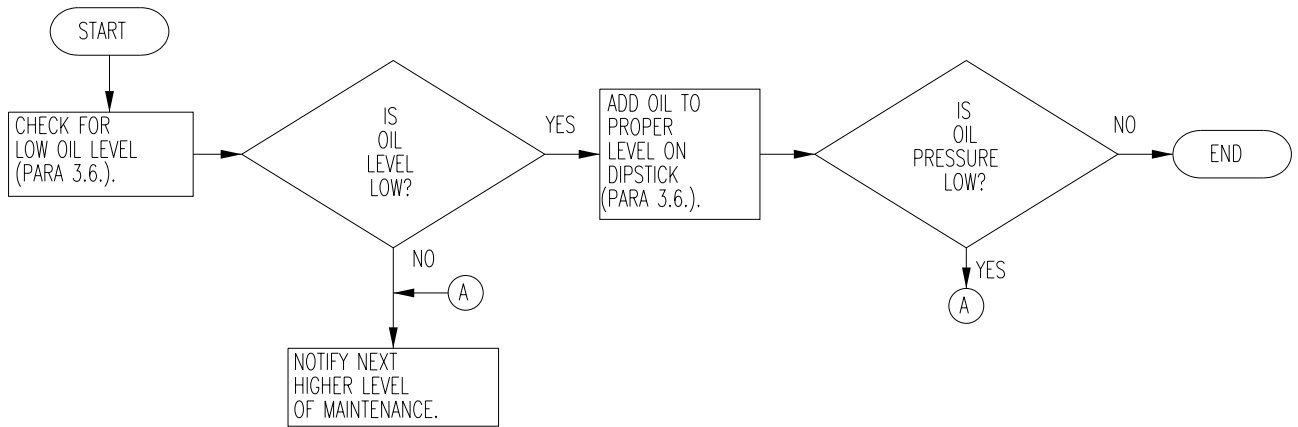

11. ENGINE OVERHEATING.

STEP 1. Check radiator for low coolant level.

- a. If coolant level is low, SERVICE Radiator (Para. 3-8.).
- b. If coolant level is adequate, proceed to step 2.

STEP 2. Check for sufficient oil in engine (Para. 3.6.).

- a. If engine oil is low, SERVICE engine oil (Para. 3.6.).
- b. If engine oil is adequate, proceed to step 3.

STEP 3. Check for air flow restriction through generator compartment and radiator.

- a. If air flow is restricted through generator compartment or radiator, remove restrictions.
- b. If air flows unrestricted through generator compartment and radiator, proceed to step 4.

STEP 4. Check for APU overload.

- a. If generator is overloaded, reduce load below rated generator power.
- b. If generator is not overloaded, notify next higher level of maintenance.

12. ENGINE COOLANT TEMPERATURE TOO LOW.

Notify next higher level of maintenance.

13. DC AMMETER SHOWS NO CHARGE WHEN VEHICLE BATTERY IS LOW OR DISCHARGED.

STEP 1. Check for dry or defective vehicle batteries.

a. If batteries are dry or defective, contact Unit Maintenance and SERVICE or REPLACE batteries.

b. If batteries are full and not defective, notify next higher level of maintenance.

14. DC AMMETER SHOWS EXCESSIVE CHARGING AFTER PROLONGED APU OPERATION.

Notify next higher level of maintenance.

15. EXCESSIVE OIL CONSUMPTION.

Notify next higher level of maintenance.

16. HIGH OIL PRESSURE.

Notify next higher level of maintenance.

17. FUEL MIXED INTO LUBRICANT OIL.

Notify next higher level of maintenance.

18. COOLANT MIXED INTO LUBRICANT OIL.

Notify next higher level of maintenance.

19. AC VOLTMETER DOES NOT INDICATE VOLTAGE.

Notify next higher level of maintenance.

20. AC VOLTMETER INDICATES VOLTAGE BUT FREQUENCY METER IS OFF SCALE.

Notify next higher level of maintenance.

ARMY TM 9-6115-670-14&P

21. AC VOLTAGE FLUCTUATES.

Notify next higher level of maintenance.

22. FREQUENCY FLUCTUATES.

Notify next higher level of maintenance.

23. MAIN AC CONTACTOR WILL NOT CLOSE.

Notify next higher level of maintenance.

24. OIL PRESSURE FAULT INDICATOR LIGHTS.

See symptom 10.

25. WATER TEMP FAULT INDICATOR LIGHTS.

See symptom 11.

26. LOW FUEL FAULT INDICATOR LIGHTS.

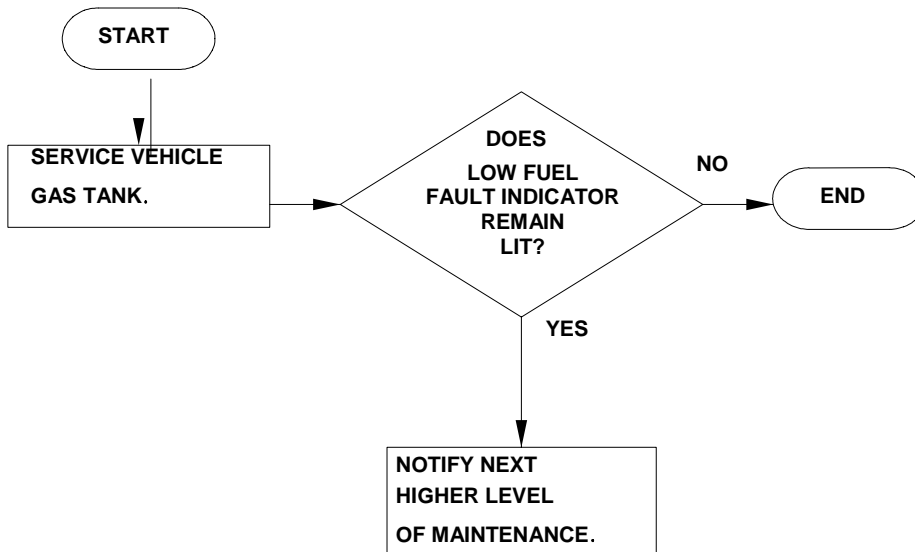

27. OVERSPEED FAULT INDICATOR LIGHTS.

Notify unit.

28. OVER-VOLTAGE FAULT INDICATOR LIGHTS.

Notify next higher level of maintenance.

Section III. OPERATOR MAINTENANCE PROCEDURES

3.4. APU PAINTING.

WARNING

CARC PAINTING

CARC paint is a health hazard. Wear protective eyewear, mask and gloves when sanding CARC painted surfaces. Failure to comply can cause personal injury.

3.5. OIL DIPSTICK.

This task covers: Replace

INITIAL SETUP

Tools

None

Equipment Condition

Vehicle engine off.

Materials/Parts

Oil Dipstick

MASTER ON/OFF switch on APU control unit set to OFF.

REPLACE

- a. Grasp ring (2, Figure 3-1) on oil dipstick (1).
- b. Pull oil dipstick (1) straight out of oil dipstick hole (3) in engine block. Do not bend oil dipstick (1) when removing.
- c. Insert end of oil dipstick (1) into oil dipstick hole (3) in engine block.
- d. Push straight down until oil dipstick (1) is fully seated against engine block.

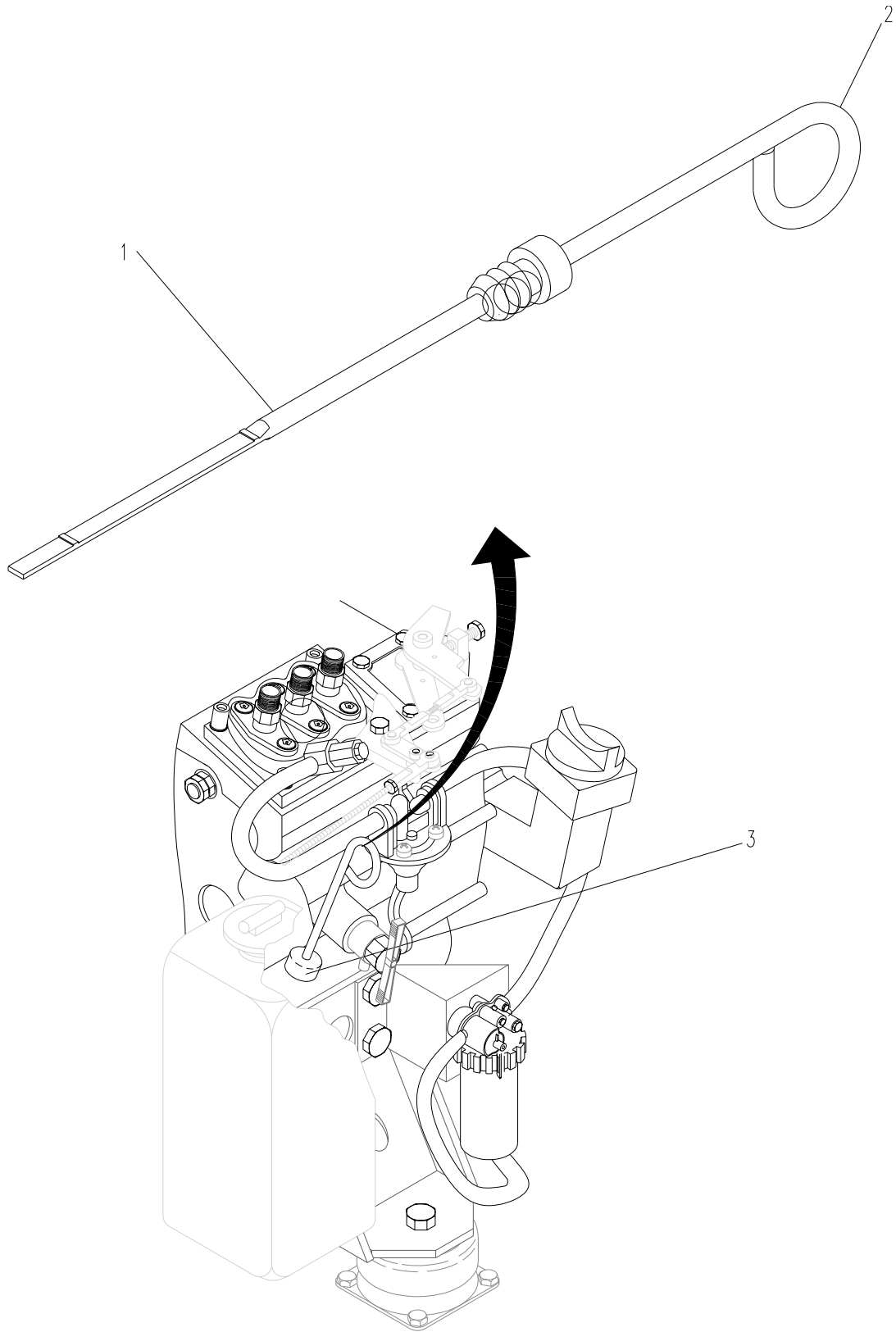

Figure 3-1. Oil Dipstick

3.6. ENGINE OIL.

This task covers: a. Inspect b. Service

INITIAL SETUP

Tools

None

Materials/Parts

Lubrication Oil
(Items 10-13, Appendix F)

Equipment Conditions

MASTER ON-OFF switch on APU controller set to OFF.

Engine warmed for five minutes.

INSPECT

- a. Remove oil dipstick (para 3.5.).
- b. Wipe engine oil off from oil dipstick with a lint-free cloth.
- c. Install oil dipstick and push down until oil dipstick is fully seated against engine block (para 3.5.).
- d. Remove oil dipstick and check to see if oil level is between the notches (1, Figure 3-2) on the oil dipstick.
- e. If oil level is at or below the bottom notch on oil dipstick, add engine oil.

SERVICE

- a. Remove oil cap (2) from side of engine by turning counter clockwise (ccw).
- b. Replenish oil gradually until oil level on oil dipstick reaches the top notch (1).
- c. Replace oil cap (2) to side of engine.

Table 3-1. Ambient Temperature and Engine Oil Type

Temperature	Engine Oil Type
Above 77°F (25°C)	MIL-PRF-21260D SAE 30W or 10W-30
32°F to 77°F (0°C to 25°C)	MIL-PRF-2104F SAE 20W or 10W-30
Below 32°F (0°C)	MIL-PRF-21260 SAE 10W or 10W-30

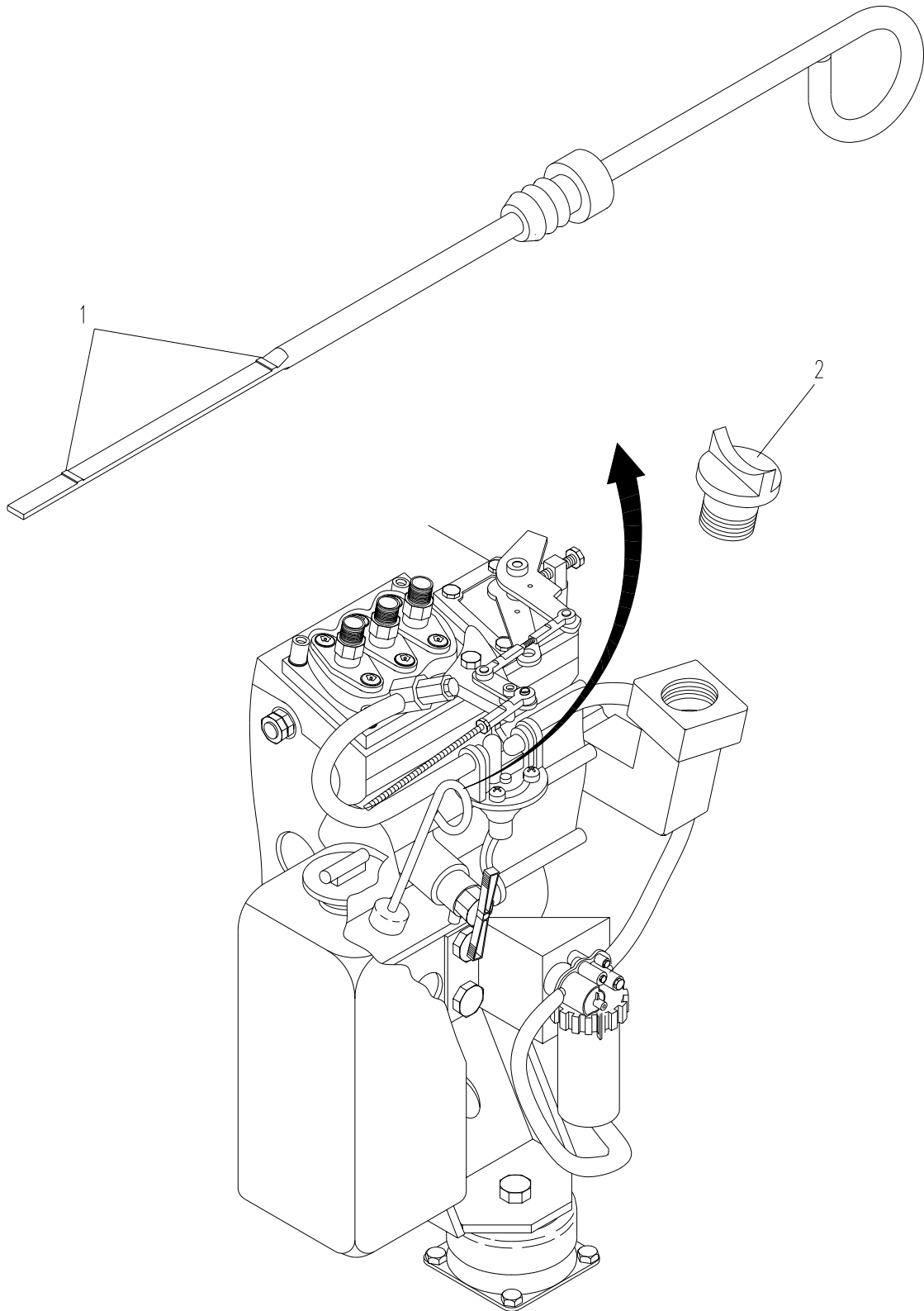

Figure 3-2. Engine Oil

3.7. RADIATOR CAP.

This task covers: Replace

INITIAL SETUP

Tools

None

Equipment Conditions

Engine stopped and allowed to cool completely.

Materials/Parts

Radiator Cap

MASTER ON-OFF switch on APU controller set to OFF.

REPLACE

WARNING

Hot coolant is under pressure. Do not remove radiator cap when engine is hot. Allow engine to cool completely before removing radiator cap. Once cooling has occurred, loosen cap slightly to relieve any excess pressure before removing the cap completely. Failure to heed this warning could result in burns or injury to personnel.

- a. Turn radiator cap (1, Figure 3-3) one quarter turn ccw and allow any excess pressure to escape.
- b. Remove cap (1) by pushing down and turning ccw; pull up and pull off (1).
- c. Install cap (1) on radiator (2) and secure by pushing down and turning clockwise (cw).

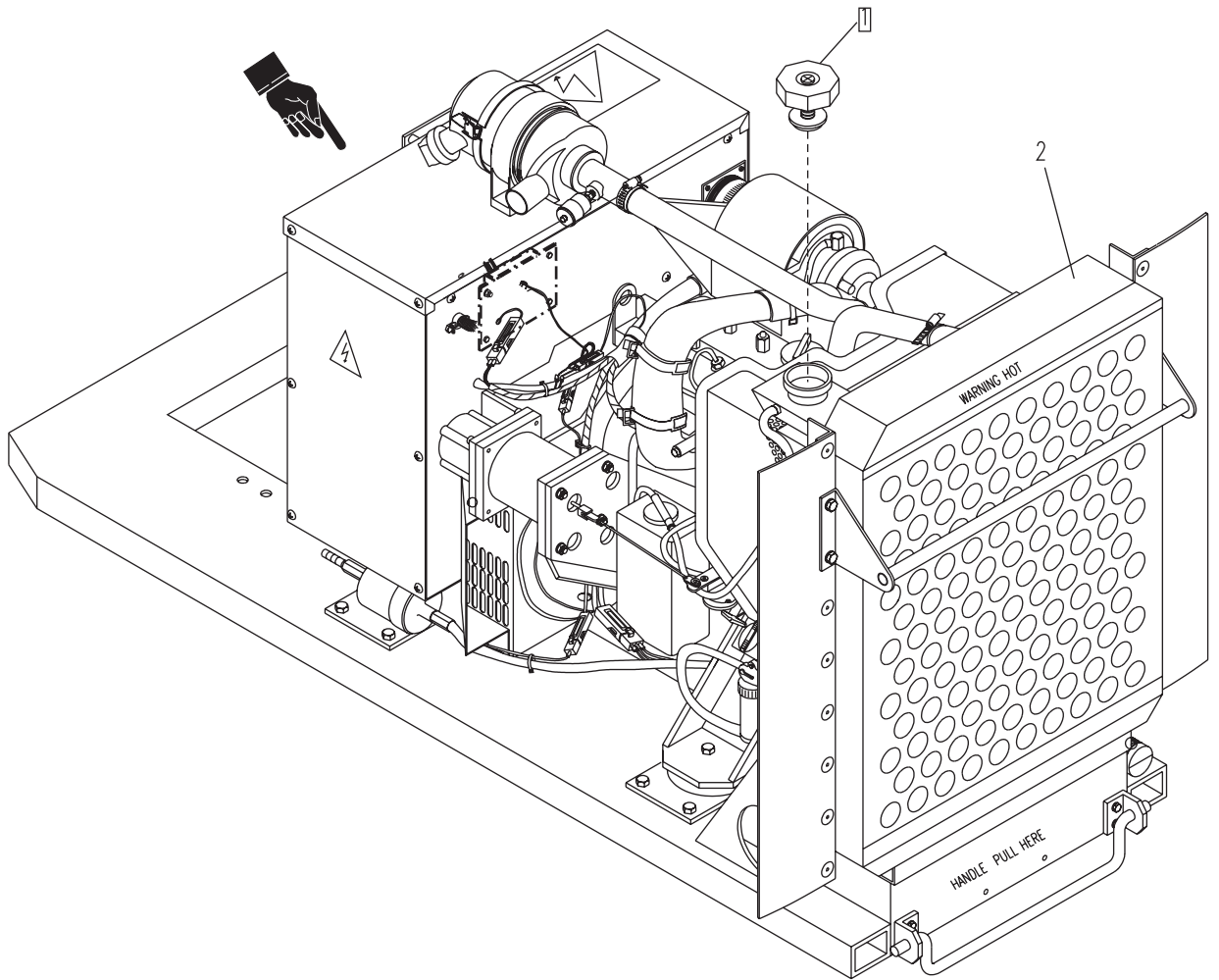

(MEP-903A, SICPS)

Figure 3-3. Radiator Cap

3.8. RADIATOR.

This task covers: Service

INITIAL SETUP

Tools

None

Materials/Parts

Coolant (see Table 3-2)

Equipment Conditions

Engine stopped and allowed to cool completely.

MASTER ON-OFF switch on APU controller set to OFF.

SERVICE

- a. Check coolant level at radiator overflow tank (1, Figure 3-4). Coolant should be halfway between “FULL” and “LOW” marks (3).

WARNING

Hot coolant is under pressure. DO NOT remove radiator cap when engine is hot. Allow engine to cool completely before removing radiator cap. Once cooling has occurred, loosen cap slightly to relieve any excess pressure before removing cap completely. Failure to observe this warning could result in injury to personnel.

- b. If coolant level is at “LOW” mark, remove cap (2) and add coolant to halfway point between “LOW” and “FULL” mark. Install cap (2).
- c. If overflow tank is empty, add coolant to tank (step b), then remove radiator cap (para 3.7.), add coolant slowly until full (1, Figure 3-3), and re-install radiator cap (para 3.7.).

Table 3-2. Freezing Points, Composition, and Specific Gravities

Lowest Ambient Temperature +20°F (-6.67°C)	Pints (liter) Glycol/Gallon (liter) Coolant	Compound Antifreeze	Ethylene Coolant Specific Gravity @ 68°F (20°C)
+20°F (-6.67°C)	1-1/2 (0.19)	Issued at full strength and ready mixed for 0° to -65°F (-17.78 to 18.33°C) temperatures for both initial installation and replenishment of losses.	1.022
+10°F (-12.22°C)	2 (0.25)		1.036
0°F (-17.78°C)	2-3/4 (0.34)		1.047

Table 3-2. Freezing Points, Composition, and Specific Gravities - Continued

Lowest Ambient Temperature +20°F (-6.67°C)	Pints (liter) Glycol/Gallon (liter) Coolant	Compound Antifreeze	Ethylene Coolant Specific Gravity @ 68°F (20°C)
-10°F (-23.33°C)	3-1/4 (0.41)		1.055
-20°F (-28.89°C)	3-1/2 (0.43)		1.062
-30°F (-34.44°C)	4 (0.49)		1.067
-40°F (-40°C)	4-1/4 (0.53)		1.073

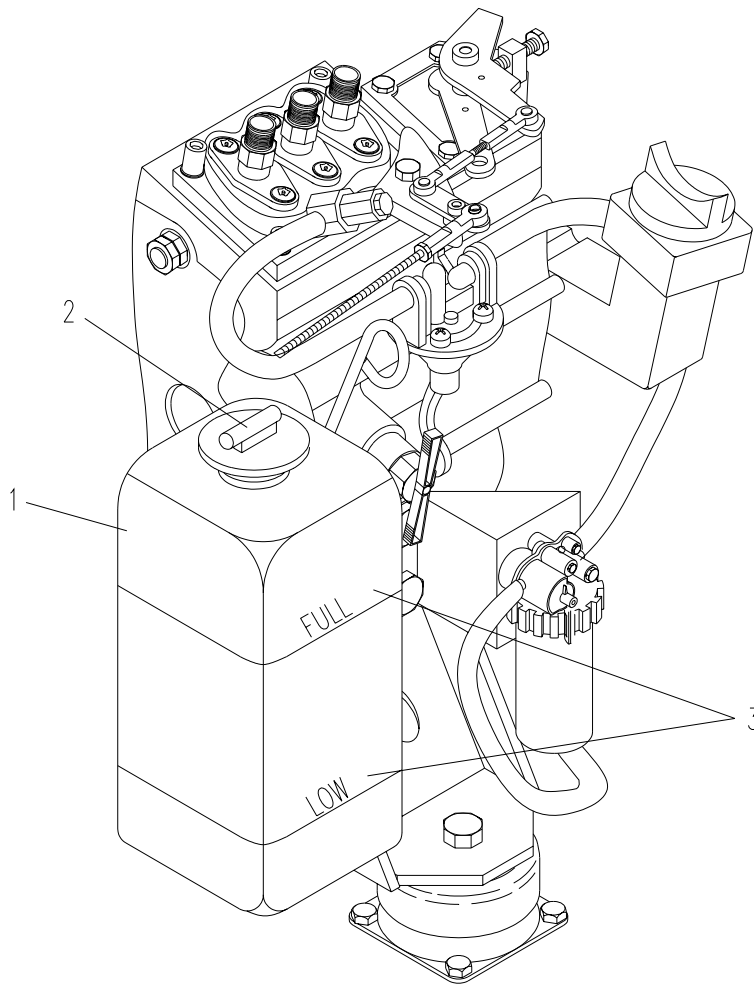

Figure 3-4. Radiator

THIS PAGE INTENTIONALLY LEFT BLANK.

CHAPTER 4
UNIT MAINTENANCE INSTRUCTIONS

		Page
Section I	Lubrication Instructions	
	4.1. APU Lubrication	4-2
Section II	Repair Parts; Special Tools; Test, Measurement, and Diagnostic Equipment (TMDE); and Support Equipment.....	4-3
	4.2 Common Tools and Equipment.....	4-3
	4.3. Special Tools, TMDE, and Support Equipment	4-3
	4.4. Repair Parts	4-3
Section III	Service Upon Receipt.....	4-3
	4.5. Inspection	4-3
	4.6. Service.....	4-3
Section IV	Equipment/User Fitting Instructions	4-4
Section V	Unit Preventive Maintenance Checks and Services (PMCS)	4-4
	4.7. Introduction to Unit PMCS Table.....	4-4
	4.8. Warnings, Cautions, and Notes	4-7
	4.9. APU Lubrication Instructions.....	4-7
Section VI	Unit Troubleshooting Procedures.....	4-10
	4.10. General.....	4-10
	4.11. Unit Troubleshooting Procedures.....	4-10
Section VII	Preparation for Storage or Shipment	4-31
	4.12. Preparation for Storage or Shipment	4-31
	4.13. Special Instructions for Administrative Storage	4-31
Section VIII	Unit Maintenance Instructions	4-32
	4.14. Engine Oil.....	4-32
	4.15. Oil Filter	4-34
	4.16. Oil Cooler.....	4-36
	4.17. Low Oil Pressure Switch	4-38
	4.18. Fan Guard, Fan Shroud, and Shroud Housing	4-41
	4.19. Radiator Sub-Assembly.....	4-45
	4.20. Radiator Coolant Drain Valve.....	4-50
	4-21. Engine Coolant Drain Valve	4-52
	4.22. Thermostat	4-54
	4.23. Fan Belt	4-56
	4.24. Radiator Hoses.....	4-59
	4.25. Temperature Sender	4-61

4.26.	Temperature Switch.....	4-63
4.27.	Breather	4-65
4.28.	Radiator Overflow Tank	4-68
4.29.	Fuel System	4-70
4.30.	Fuel Filter Assembly	4-72
4.31.	Fuel Pump Assembly	4-75
4.32.	Fuel Day Tank Assembly (JTACS and WIN-T)	4-78
4.33.	Fuel Day Tank Assembly (SICPS).....	4-84
4.34.	Fuel Feeder Pump	4-88
4.35.	Fuel Lines and Fittings (JTACS, SICPS and WIN-T)	4-91
4.36.	Battery Charging Alternator	4-95
4.37.	Starter	4-98
4.38.	Glow Plug.....	4-100
4.39.	Muffler Wrap	4-103
4.40.	Muffler, (JTACS) Model MEP-903B and (WIN-T) Model MEP-903C	4-105
4.41.	Muffler (SICPS), Model MEP-903A	4-107
4.42.	Exhaust Pipe, (JTACS) Model MEP-903B and (WIN-T) Model MEP-903C.....	4-109
4.43.	Exhaust Pipe (SICPS), Model MEP-903A	4-111
4.44.	Engine Turbocharger	4-113
4.45.	Air Filter (SICPS, JTACS, and WIN-T)	4-115
4.46.	DELETED	4-118
4.47.	Air Intake Pipe.....	4-119
4.48.	Governor Control Assembly.....	4-121
4.49.	Actuator Solenoid.....	4-124
4.50.	Actuator Linkage.....	4-127
4.51.	Electrical Output Terminal Board.....	4-131
4.52.	Contactors Mounting Plate	4-133
4.53.	Main AC Contactor.....	4-136
4.54.	Ground Strap	4-139
4.55.	Current Shunt.....	4-141
4.56.	Speed Sensor	4-144
4.57.	Electrical Meters	4-145
4.58.	Hour Meter	4-149
4.59.	AC Voltage Adjust Potentiometer	4-151
4.60.	Emergency Shut-Down Switch	4-154
4.61.	Toggle Switches.....	4-156
4.62.	START-PREHEAT Toggle Switch	4-158
4.63.	Indicator Lamps	4-160
4.64.	Cylinder Head Cover (Valve Cover)	4-162

NOTE

Refer to “Table 1-1. Differences Between Models” for differences between MEP-903A, MEP-903B, and MEP-903C, which may not be, depicted in the TM illustrations.

Section I. LUBRICATION INSTRUCTIONS

4.1. APU LUBRICATION.

For the Auxiliary Power Unit 10 kW, 120/240 VAC, 60 Hz (APU) lubrication instructions, refer to Section V, Unit Preventive Maintenance Checks and Services (PMCS).

**Section II. REPAIR PARTS; SPECIAL TOOLS;
TEST, MEASUREMENT, AND DIAGNOSTIC EQUIPMENT (TMDE);
AND SUPPORT EQUIPMENT**

4.2 COMMON TOOLS AND EQUIPMENT.

For authorized common tools and equipment, refer to the Modified Table of Organization and Equipment (MTOE), CTA 50-970, or CTA 8-1010 as applicable to your unit.

4.3. SPECIAL TOOLS, TMDE, AND SUPPORT EQUIPMENT.

For a listing of special tools, TMDE, and support equipment authorized for use on this equipment, refer to Appendix C, Repair Parts and Special Tools List (RPSTL), and Appendix B, Maintenance Allocation Chart (MAC), of this manual.

4.4. REPAIR PARTS.

Repair parts are listed and illustrated in Appendix C, Repair Parts and Special Tools List, of this manual.

Section III. SERVICE UPON RECEIPT

4.5. INSPECTION.

Perform a complete visual inspection of the APU for evidence of damage, which may have occurred during shipment. Inspect the generator for obvious signs of damage and corrosion. Check the engine and its components for any visible damage. Check the engine air filter and exhaust opening for obstructions. Check fan belt for proper adjustment. Perform a thorough visual inspection of the APU for loose or missing hardware, leakage, or damaged or missing parts. Check loose connections and terminals including fuel hoses. Tighten any loose connections.

4.6. SERVICE.

4.6.1. Lubrication System. Verify the drain plug is installed properly in the engine crankcase drain tube and close valve. Check oil level and add engine oil as needed (para 3.6.). Add engine oil type according to ambient air temperature (Table 3-1).

4.6.2. Cooling System. Remove the radiator cap and fill the radiator with coolant as specified in Table 4-1, and replace the cap.

NOTE

After initial engine start-up, allow engine to attain normal operating temperature. Shut down engine and allow to cool for ten minutes. Check coolant level at radiator overflow tank. Add coolant if necessary.

Table 4-1. Freezing Points, Composition, and Specific Gravities of Military Antifreeze Materials

Lowest Ambient Temperature +20°F (-6.67°C)	Pints (liters) Glycol/Gallon (liter) Coolant	Compound Antifreeze	Ethylene Coolant Specific Gravity @ 68°F (20°C)
+20°F (-6.67°C)	1-1/2 (0.19)	Issued at full strength and ready mixed for 0° to -65°F (-17.8 to -53.9°C) temperatures for both initial installation and replenishment of losses.	1.022
+10°F (-12.22°C)	2 (0.25)		1.036
0°F (-17.78°C)	2-3/4 (0.34)		1.047
-10°F (-23.33°C)	3-1/4 (0.41)		1.055
-20°F (-28.89°C)	3-1/2 (0.43)		1.062
-30°F (-34.44°C)	4 (0.49)		1.067
-40°F (-40°C)	4-1/4 (0.53)		1.073
NOTE			
Maximum protection is obtained at 60% by volume (4.8 pints (2.256 liters)) of ethylene per gallon (liter) of solution.			

Section IV. EQUIPMENT/USER FITTING INSTRUCTIONS

There are no equipment/user fitting instructions associated with the APU.

Section V. UNIT PREVENTIVE MAINTENANCE CHECKS AND SERVICES (PMCS)

4.7 INTRODUCTION TO UNIT PMCS TABLE.

4.7.1. General. Table 2-2 (PMCS table) has been provided so you can keep your equipment in good operating condition and ready for its primary mission.

4.7.2. PMCS Procedures. The PMCS table is divided into five columns. Each column is explained in the following paragraphs.

4.7.2.1 Item No. Column. Numbers in this column are for reference. When completing DA Form 2404 (Equipment Inspection and Maintenance Worksheet), include the item number for the check/service indicating a fault. Item numbers also appear in the order that you must perform checks and services for the intervals listed.

4.7.2.2 Interval Column. This column informs you when you must perform the procedure in the procedure column. "BEFORE" procedures must be completed before you operate the equipment for its intended mission. "DURING" procedures must be completed during the time you are operating the equipment for its intended mission. "AFTER" procedures must be completed immediately after you have operated the equipment. Perform "WEEKLY" procedures at the listed interval.

4.7.2.3 Location, Item to Check/Service Column. This column lists the location and the item to be checked or serviced. The item location is underlined.

4.7.2.4 Procedure Column. This column gives the procedure for checking or servicing the item listed in the location, item to check/service column. You must perform the procedure to know if the APU is ready or available for its intended mission or operation. You must perform the procedure at the time stated in the interval column.

4.7.2.5 Not Fully Mission Capable If: Column Information in this column informs you of faults that will keep your equipment from being capable of performing its primary mission. If you make checks or services that show faults listed in this column, do not operate the equipment.

4.7.2.6 Other Table Entries. Be sure to observe all special information and notes that appear in your table.

4.7.3. Special Instructions. Preventive maintenance is not limited to performing the checks and services listed in the PMCS table. Covering unused receptacles, stowing unused accessories, and other routine procedures such as equipment inventory, cleaning components, and touch-up painting are not listed in the table. These are things you should do any time you see that they need to be done. If a routine check is listed in the PMCS table, it is because experience has shown that problems may occur with this item. Take along the tools and cleaning cloths needed to perform the required checks and services. Use the information in the following paragraphs to help you identify problems at any time. Use the following information to help identify potential problems before and during checks and services.

WARNING

Dry cleaning solvent used to clean parts is potentially dangerous to personnel and property. Clean parts in a well-ventilated area. Avoid inhalation of solvent fumes. Wear goggles and rubber gloves to protect eyes and skin. Wash exposed skin thoroughly. Do not smoke or use near open flame or excessive heat. Failure to observe this warning can cause severe injury to personnel or DEATH.

CAUTION

Keep cleaning solvents, gasoline and lubricants away from rubber or soft plastic parts. They will deteriorate material.

- a. Keep it clean. Dirt, grease, and oil get in the way and may cover up a serious problem. Use dry cleaning solvent to clean metal surfaces.
- b. Use soap and water to clean rubber or plastic parts and material.
- c. Check all bolts, nuts, and screws to make sure they are not loose, missing, bent, or broken. Do not try to check them with a tool, but look for chipped paint, bare metal, or rust around bolt heads. If you find one loose, report it to the next higher level of maintenance.
- d. Inspect welds for loose or chipped paint, rust, or gaps where parts are welded together. If a broken weld is found, report it to the next higher level of maintenance.
- e. Inspect electrical wires, connectors, terminals, and receptacles for cracked or broken insulation, bare wires, and loose or broken connectors. Tighten loose connectors. Examine terminals and receptacles for serviceability. If deficiencies are found, report them to the next higher level of maintenance.

- f. Inspect hoses and fluid lines. Look for wear, damage, and leaks. Make sure that clamps and fittings are tight. Wet spots and stains around a fitting or connector can mean a leak. If a leak comes from a loose connector, or if something is broken or worn out, report it to the next higher level of maintenance.

4.7.4. Leakage Definitions. You must know how fluid leakage affects the status of your equipment. The following are definitions of the types/classes of leakage you need to know to be able to determine the status of your equipment. Learn and be familiar with them. When in doubt, notify your supervisor.

<u>Leakage Class</u>	<u>Leakage Definition</u>
Class I	Seepage of fluid (as indicated by wetness or discoloration) not great enough to form drops.
Class II	Leakage of fluid great enough to form drops, but not enough to cause drops to drip from the item being checked/inspected.
Class III	Leakage of fluid great enough to form drops that drip from the item being checked/inspected.

4.7.5 Operation of Generator Set with Minor Leaks.

CAUTION

Equipment operation is allowable with minor leakage (Class I or II) of any fluid except fuel. Fluid capacity must be considered before deciding to continue operation of the equipment with minor leaks. When operating with Class I or II leaks, fluid level must be checked more often than required by the PMCS table. Parts without fluid will stop working and/or cause equipment damage.

- a. Consider the equipment's capacity for the fluid that is leaking. If the capacity is small, the fluid level may soon become too low for continued operation. If in doubt, notify your supervisor.
- b. Check the fluid level more often than required in the PMCS table. Add fluid as needed.

4.7.6. Corrosion Prevention and Control (CPC). CPC of Army material is of continuing concern. It is important that any corrosion problems with the equipment be reported so that the problem can be corrected and improvements can be made to prevent the problem in future items. While corrosion is typically associated with rusting of metals, it can also include deterioration of other materials, such as rubber and plastic. Unusual cracking, softening, swelling, or breaking of these materials may be a corrosion problem. If a corrosion problem is identified, it can be reported using Standard Form 368, Product Quality Deficiency Report. Use of key words such as "corrosion," "rust," "deterioration," or "cracking" will ensure that the information is identified as a CPC problem. The form should be submitted to the address specified in DA PAM 738-750.

4.7.7. Order in Which PMCS Will be Done. Figure 2-2 shows the order in which you are to perform your PMCS. The number callouts on Figure 2-2 correspond to the numbers in the Item No. column of Table 2-2, for "Before" PMCS.

4.8. WARNINGS, CAUTIONS, AND NOTES.

Always observe WARNINGS, CAUTIONS, and NOTES appearing in your PMCS table. Warnings and cautions appear before applicable procedures. You must observe WARNINGS to prevent serious injury or death to yourself and others. You must observe CAUTIONS to prevent your equipment from being damaged. You must observe NOTES to ensure procedures are performed properly.

NOTE

If the equipment must be kept in continuous operation, check and service only those items that can be checked and serviced without disturbing operation. Make the complete checks and services when the equipment can be shut down.

4.9. APU LUBRICATION INSTRUCTIONS.

4.9.1. Diesel Engine Lubrication Instructions. The APU's engine oil level shall be checked on a daily basis (para 3.1.). Engine oil shall be replenished as needed. Engine oil and oil filter shall be changed every 100 hours of operation (para 4.14. and 4.15.).

4.9.2. 10 kW Generator Lubrication Instructions. There are no lubrication instructions for the 10 kW generator.

4.9.3. Army Oil Analysis Program (AOAP). The APU is enrolled in the AOAP. (Refer to AR 738-750.)

Table 4-2. Unit Preventive Maintenance Checks and Services (PMCS)

Item No.	Interval	Item To Check/Service	Procedure	Not Fully Mission Capable If:
1	40H	Radiator	Check coolant level. Add coolant as required (para 3.8.).	Coolant is exhausted.
2	50 H	Fuel pipes/clamps	Inspect for loose connections or excessive wear.	Hoses are loose or excessive wear or deterioration is visible.
3	100 H	APU	Check entire APU for missing, loose, or damaged parts and hardware. Check for unusual wear or deterioration.	Missing, loose, or damaged parts and hardware, or unusual wear.
4	100 H	Engine oil	Replace engine oil (para 4.14.).	Used or dirty oil.
5	100 H	Oil filter	Replace oil filter (para 4.15.).	Clogged or dirty oil filter.
6	100 H	Breather and Breather Tube	Inspect breather and breather tube for damage or blockage. Clean breather and breather tube (para 4.27.).	Breather or breather tube damaged or blocked. Dirty breather or breather tube.
7	100 H	Fuel filter	Clean fuel filter (para 4.30.).	Water or sediment in fuel filter.

Table 4-2. Unit Preventive Maintenance Checks and Services (PMCS) – Continued

Item No.	Interval	Item To Check/Service	Procedure	Not Fully Mission Capable If:
8	100 H	Fan belt	Inspect for proper adjustment and excessive wear (para 4.23.).	Worn, frayed, cracked, or loose fan belt.
9	100 H	Fan Shroud	Check fan shroud alignment (Para 4.18.).	Blades of shroud touch or fan shroud missing.
10	100 H	Radiator hoses and clamps	Inspect for loose connections or excessive wear (para 4.24.). <p style="text-align: center;">WARNING</p> Compressed air shall not be used for cleaning purposes except where reduced to less than 29 pounds per square inch gauge (psig) (199.94 kPa) and then only with effective chip guarding and personnel protective equipment. Compressed air is dangerous and can cause serious bodily harm if protective means or methods are not observed to prevent chip or particle (of whatever size) from being blown into the eyes or unprotected skin of the operator or other personnel. <p style="text-align: center;">CAUTION</p> Clean air filter every 50 hours in dusty or sandy environments.	Hoses are loose or excessive wear or deterioration is visible. Deteriorated radiator hose.
11	100 H	Air filter	Clean air filter element (para 4.45.).	Dirty or blocked air filter.
12	400 H	Air filter	Replace air filter (para 4.45.) (SICPS, JTACS and WIN-T).	Old, clogged, or dirty air filter.
13	400 H	Fuel filter	Replace fuel filter (para 4.30.).	Fuel filter old. Water or sediment in fuel filter.
14	500 H	Governor linkage	Clean and lubricate governor linkage and rod ends.	Governor linkage and rod ends dirty or needs lubrication (para 4.50.).

Table 4-2. Unit Preventive Maintenance Checks and Services (PMCS) - Continued

Item No.	Interval	Item To Check/Service	Procedure	Not Fully Mission Capable If:
15	500 H	Radiator	Service radiator (para 4.19.).	Clogged radiator or exhausted coolant.
16	800 H	Injection nozzle	Check spray conditions at direct support level (para 5.13.).	Nozzle spray clogged or uneven.
17	800 H	Valves	Check valve clearance at Direct Support level (para 4.20. and/or 4.21.).	Valve clearance exceeds allowable limit.
18	1000 H	Fan belt	Replace fan belt (para 4.23.). <u>WARNING</u> Always point fuel spray away from direction of personnel. Contact with the fuel spray could cause blood poisoning and cell damage. Always aim spray into a suitable container.	Worn, frayed, cracked, or loose fan belt.
19	1000 H	Nozzles	Check injection pressure at Direct Support level (para 5.13.).	Injection pressure exceeds allowable limit.
20	3000 H	Governor system	Examine all interior and exterior components and replace as necessary.	Broken or worn governor components found.
21	3000 H	Muffler	Check for leaks, restrictions, and accumulation of carbon and replace as necessary.	Leaks or restrictions found.
22	8000 H	Generator bearing	Check the bearing at General Support level and replace if needed (para 6.37.).	Bearing worn or pitted.
23	24 Months	Radiator hoses/clamps	Inspect radiator hoses and clamps (para 4.24.).	Deteriorated radiator hoses.
24	24 Months	Fuel lines and fittings	Inspect fuel lines and fittings. Replace as required (para 4.35.).	Deteriorated fuel lines.
25	Annually	Fuel day tank	Service (para 4.32 or 4.33.).	On Condition.

Section VI. UNIT TROUBLESHOOTING PROCEDURES

4.10. GENERAL.

This section contains troubleshooting procedures to determine the probable cause of observed equipment malfunctions. Branching logic trees are provided to isolate the faulty component and offer corrective actions to eliminate the malfunction.

4.11. UNIT TROUBLESHOOTING PROCEDURES.

The following pages list common malfunctions that may occur during operation or maintenance of the APU, followed by a troubleshooting procedure. Refer to the symptom index to locate the troubleshooting procedure for the malfunction you observe. Each troubleshooting procedure consists of a branching logic tree. Perform the test or inspection, and the recommended corrective action in the order listed in the logic tree. If the malfunction is corrected by a specific corrective action, do not continue with any remaining steps. If the corrective actions do not correct the malfunction, notify your supervisor or Direct Support Maintenance.

SYMPTOM INDEX

Symptom	Page
1. Engine fails to turn over.....	4-11
2. Engine cranks but fails to start.....	4-12
3. Engine starts, but stops when start-preheat switch is released	4-14
4. Engine stops suddenly.....	4-15
5. Engine runs erratically or misfires	4-16
6. Engine does not develop full power.....	4-19
7. Engine knocks.....	4-20
8. Black smoke in exhaust.....	4-21
9. Blue or white smoke in exhaust.....	4-22
10. Low oil pressure.....	4-23
11. Engine overheating.....	4-24
12. Engine coolant temperature too low	4-25
13. DC ammeter shows no charge when vehicle battery is low or discharged.....	4-26
14. DC ammeter shows excessive charging after prolonged APU operation	4-27
15. Excessive oil consumption.....	4-28
16. High oil pressure.....	4-28
17. Fuel mixed into lubricant oil	4-29
18. Coolant mixed into lubricant oil.....	4-29
19. AC voltmeter does not indicate voltage	4-29
20. AC voltmeter indicates voltage but frequency meter is off scale.....	4-29
21. AC voltage fluctuates.....	4-29
22. Frequency fluctuates	4-29
23. Main AC contactor will not close.....	4-29
24. Oil pressure fault indicator lights	4-29
25. Water temp fault indicator lights	4-29
26. Overspeed fault indicator lights	4-30
27. Over-voltage fault indicator lights	4-30

1. ENGINE FAILS TO TURN OVER.

STEP 1. Check for adequate voltage from vehicle to generator set.

- a. If there is low or no voltage from vehicle to generator set, check DC meter in shelter/vehicle. If low or no voltage still exists, troubleshoot vehicle batteries and electrical wiring between generator set and vehicle batteries (see system TM). If low or no voltage still exists, charge or replace vehicle battery.
- b. If there is adequate voltage to generator set, proceed to step 2.

STEP 2. Check for loose or corroded battery cables, terminals and posts.

- a. If battery cables, terminals and posts are corroded, clean and tighten.
- b. If battery cables are clean, proceed to step 3.

STEP 3. Test for defective MASTER ON/OFF switch.

- a. If the MASTER ON-OFF switch is defective, replace switch.
- b. If the MASTER ON-OFF switch is functioning properly, proceed to step 4.

STEP 4. Test for defective ENGINE START switch.

- a. If the ENGINE START switch is defective, replace switch.
- b. If the ENGINE START switch is functioning properly, proceed to step 5.

STEP 5. Test for defective EMERGENCY STOP switch.

- a. If the EMERGENCY STOP switch is defective, replace switch.
- b. If the EMERGENCY STOP switch is functioning properly, proceed to step 6.

STEP 6. Test for defective starter (para 4.37.).

- a. If the EMERGENCY STOP switch is defective, replace switch.
- b. If the EMERGENCY STOP switch is functioning properly, notify next higher level of maintenance.

2. ENGINE CRANKS BUT FAILS TO START.

STEP 1. Check for clogged or dirty fuel filter.

- a. If the fuel filter is clogged or dirty, SERVICE fuel filter (para 4.30.).
- b. If the fuel filter is clean, proceed to step 2.

STEP 2. Check for obstructions, cracks or leaks in fuel supply lines.

- a. If fuel lines are clogged, cracked, or leaking, replace fuel lines (para 4.35.).
- b. If fuel lines are free of obstructions, cracks or leaks, proceed to step 3.

STEP 3. Check for air in fuel system.

- a. Tighten any loose fuel lines and bleed the fuel system.
- b. If the APU does not start, proceed to step 4.

STEP 4. Check for proper installation and operation of glow plugs.

- a. If the glow plugs are improperly installed, non operational, or defective, reinstall, REPAIR or REPLACE as required.
- b. If the glow plugs are functioning properly, proceed to step 5.

STEP 5. Check fuel filter sediment container for water or other contaminants in the fuel, incorrect grade or fuel type.

- a. If the fuel is contaminated, drain entire fuel system including vehicle fuel tank and APU day tank (para 4.32. or 4.33.).
- b. Replace fuel filter (para 4.30.) and service with clean fuel.
- c. Bleed fuel system.
- d. If the fuel is uncontaminated, proceed to step 6.

STEP 6. Check for fuel leaks at injection pipes.

- a. If fuel is leaking from injection pipes, stop the leak by tightening the retaining nuts or replacing the fuel injection lines.
- b. If fuel is not leaking from the injection pipe lines, proceed to step 7.

STEP 7. Check for compression leak from cylinder.

- a. If a compression leak exists from a loose injection nozzle, tighten injection nozzle to proper torque value.
- b. If the injection nozzle is tight, proceed to step 8.

STEP 8. Check for defective fuel transfer pump.

- a. If fuel transfer pump is defective, REPLACE fuel transfer pump (para 4.31.).
- b. If fuel transfer pump functions properly, proceed to step 9.

2. ENGINE CRANKS BUT FAILS TO START – CONTINUED.

STEP 9. Check for defective fuel feeder pump (para 4.34.).

- a. If fuel feeder pump is defective, REPLACE fuel feeder pump (para 4.34.).
- b. If fuel feeder pump functions properly, proceed to step 10.

STEP 10. Check for defective day tank low fuel cutoff switch (para 4.32. or 4.33.).

- a. If day tank low fuel cutoff switch is defective, REPLACE low fuel cutoff switch (para 4.32. or 4.33.).
- b. If day tank low fuel cutoff switch functions properly, proceed to step 11.

STEP 11. Check for proper type, viscosity and weight of oil in engine for ambient temperatures.

- a. If engine contains improper oil, SERVICE engine oil (para 4.14.).
- b. If engine oil is correct, proceed to step 12.

STEP 12. Check for clogged air filter.

- a. If air filter is clogged, SERVICE air filter or REPLACE as needed (para 4.45. or 4.46.).
- b. If air filter is clean, notify next higher level of maintenance.

3. ENGINE STARTS, BUT STOPS WHEN START-PREHEAT SWITCH IS RELEASED.

STEP 1. Check for dirty or clogged fuel filter.

- a. If fuel filter is dirty or clogged, SERVICE fuel filter (para 4.30.).
- b. If the fuel filter is clean, proceed to step 2.

STEP 2. Check for clogged oil filter assembly.

- a. If oil filter is clogged, SERVICE oil filter assembly (para 4.14.).
- b. If oil filter is clear, proceed to step 3.

STEP 3. Test for defective START-PREHEAT switch.

- a. If START-PREHEAT switch is defective, REPLACE switch (para 4.62.).
- b. If START-PREHEAT switch is functioning properly, proceed to step 4.

STEP 4. Check for defective low oil pressure sender switch.

- a. If low oil pressure sender switch is defective, REPLACE defective oil pressure sender switch (para 4.17.).
- b. If oil pressure sender switch is functioning properly, proceed to step 5.

STEP 5. Check if WATER TEMP indicator light is on.

- a. If the WATER TEMP light is on, refer to SYMPTOM 11.
- b. If the high coolant temperature indicator light is not lit, proceed to step 6.

STEP 6. Check for defective fuel transfer pump.

- a. If the fuel transfer pump is defective, REPLACE fuel transfer pump (para 4.31.).
- b. If the fuel transfer pump is functioning properly, proceed to step 7.

STEP 7. Test for defective DAY TANK LEVEL switch and LOW FUEL CUT-OFF switch (para 4.32. or 4.33.).

- a. If the defective DAY TANK LEVEL switch or the LOW FUEL CUT-OFF switch are defective, REPLACE defective switch (para 4.32. or 4.33.).
- b. If the DAY TANK LEVEL switch and LOW FUEL CUT-OFF switch are functioning properly, notify next higher level maintenance.

4. ENGINE STOPS SUDDENLY.

STEP 1. Check for tripped protective devices (OIL PRESSURE, WATER TEMP, LOW FUEL, OVERSPEED AND OVER VOLTAGE).

- a. If there are tripped protective devices, correct fault indicated. See SYMPTOMS 24-27.
- b. If there are no tripped protective devices, proceed to step 2.

STEP 2. Check for low or no fuel level condition.

- a. If fuel level is low, refill fuel tank.
- b. If fuel tank has fuel, proceed to step 3.

STEP 3. Check for loose fuel line connections, obstruction in fuel lines, and air in fuel lines.

- a. If the fuel line connections are loose, the fuel lines contain an obstruction or there is air in fuel lines, tighten fuel line connections, remove the obstruction from the fuel supply lines or replace the fuel lines and bleed air from fuel system (para 4.35.).
- b. If the fuel line connections are tight, the fuel supply lines contain no obstructions and the fuel system does not require bleeding, proceed to step 4.

STEP 4. Check fuel filter sediment container for water and contaminated fuel, incorrect grade or fuel type.

- a. If the fuel is contaminated, drain entire fuel system including vehicle fuel tank and APU day tank (para 4.32. or 4.33.). Replace fuel filter (para 4.30.). Service with proper grade fuel. Bleed fuel system.
- b. If the fuel is not contaminated, notify next higher level of maintenance.

5. ENGINE RUNS ERRATICALLY OR MISFIRES.

STEP 1. Check for clogged air filter (para 4.45.).

- a. If air filter is clogged, SERVICE or REPLACE air filter as required.
- b. If air filter is not clogged, proceed to step 2.

STEP 2. Check for clogged or dirty fuel filter.

- a. If fuel filter is clogged or dirty, REPLACE fuel filter (para 4.30.).
- b. If fuel filter is not clogged or dirty, proceed to step 3.

STEP 3. Check fuel filter sediment container for contaminated fuel, incorrect grade or fuel type.

- a. If the fuel is contaminated, drain entire fuel system including vehicle fuel tank and APU day tank (para 4.32. or 4.33.). Replace fuel filter (para 4.30.). Service with proper grade fuel. Bleed fuel system.
- b. If the fuel is uncontaminated, proceed to step 4.

STEP 4. Check for obstruction in fuel supply line.

- a. If the fuel line is obstructed, remove obstruction or replace fuel line.
- b. If the fuel line is not obstructed, proceed to step 5.

STEP 5. Check for fuel leak due to loose injection pipe retaining nut(s).

- a. If fuel is leaking from injection pipes, stop the leak by tightening the retaining nuts or replacing the fuel injection lines.
- b. If fuel is not leaking from the injection pipe lines, proceed to step 6.

5. ENGINE RUNS ERRATICALLY OR MISFIRES – Continued.

STEP 6. Check for clogged fuel overflow pipe from fuel injectors.

- a. If the Fuel Overflow Pipe is clogged, replace Fuel Overflow Pipe.
- b. If the Fuel Overflow Pipe is not clogged, proceed to step 7.

STEP 7. Check for proper adjustment of Governor Linkage.

- a. If the Governor Linkage is improperly adjusted, adjust Governor Linkage (para 4.50.).
- b. If the Governor Linkage is properly adjusted, proceed to step 8.

STEP 8. Check for proper gap between speed sensor and flywheel (para 4.56.).

- a. If the gap between the speed sensor and flywheel is not set properly, adjust speed sensor gap (para 4.56.).
- b. If the gap between the speed sensor and flywheel is set properly, proceed to step 9.

STEP 9. Check for defective Actuator/Solenoid (para 4.49.).

- a. If the Actuator/Solenoid is defective, replace Actuator/Solenoid (para 4.49.).
- b. If the Actuator/Solenoid is functioning properly, proceed to step 10.

STEP 10. Check for defective Governor Control Assembly (para 4.48.).

- a. If the Governor Control Assembly is defective, replace Governor Control Assembly (para 4.48.).
- b. If the Governor Control Assembly is operating properly, proceed to step 11.

5. ENGINE RUNS ERRATICALLY OR MISFIRES – Continued.

STEP 11. Check for blocked or clogged exhaust pipe or muffler.

- a. If the exhaust pipe or muffler is blocked or clogged, remove blockage or replace exhaust pipe or muffler.
- b. If the exhaust pipe and muffler are free of obstructions, proceed to step 12.

STEP 12. Check for defective Speed Sensor.

- a. If the Speed Sensor is defective, replace Speed Sensor.
- b. If the Speed Sensor is not defective, notify next higher level of maintenance.

6. ENGINE DOES NOT DEVELOP FULL POWER.

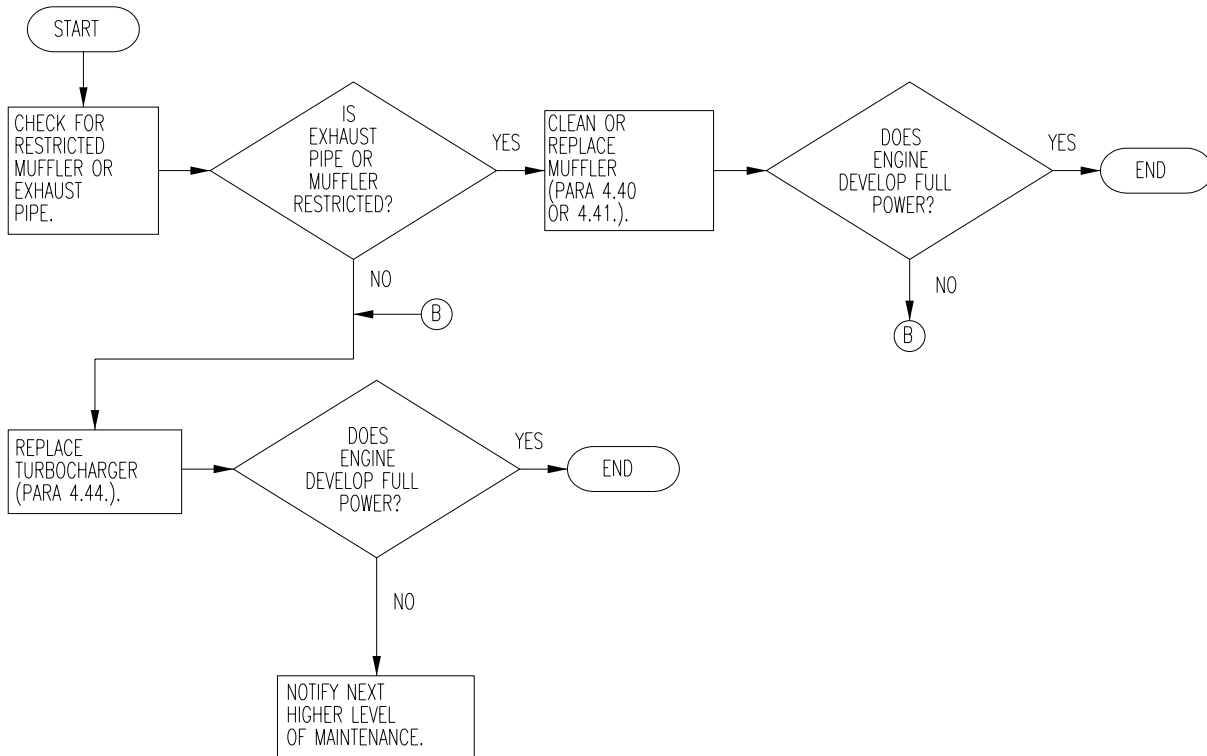

7. ENGINE KNOCKS.

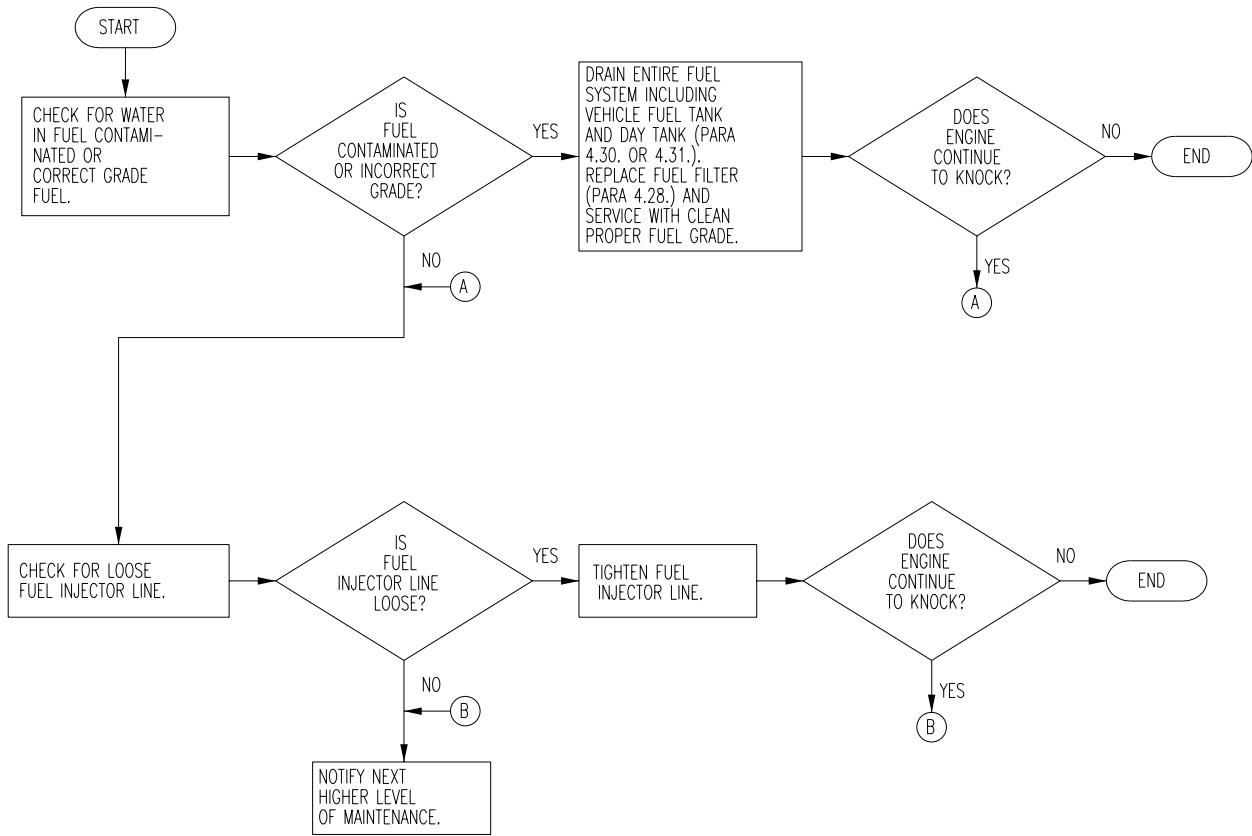

8. BLACK SMOKE IN EXHAUST.

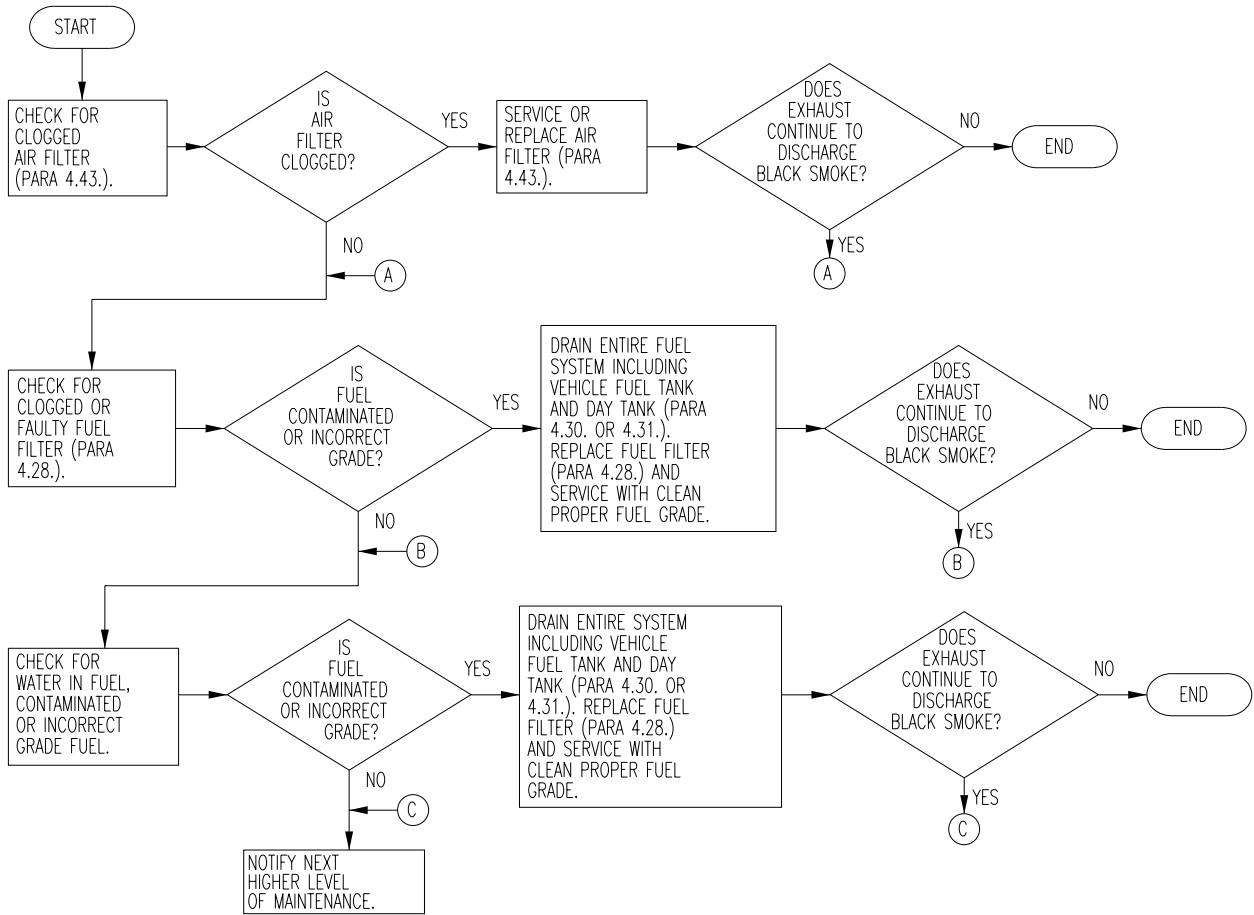

9. BLUE OR WHITE SMOKE IN EXHAUST.

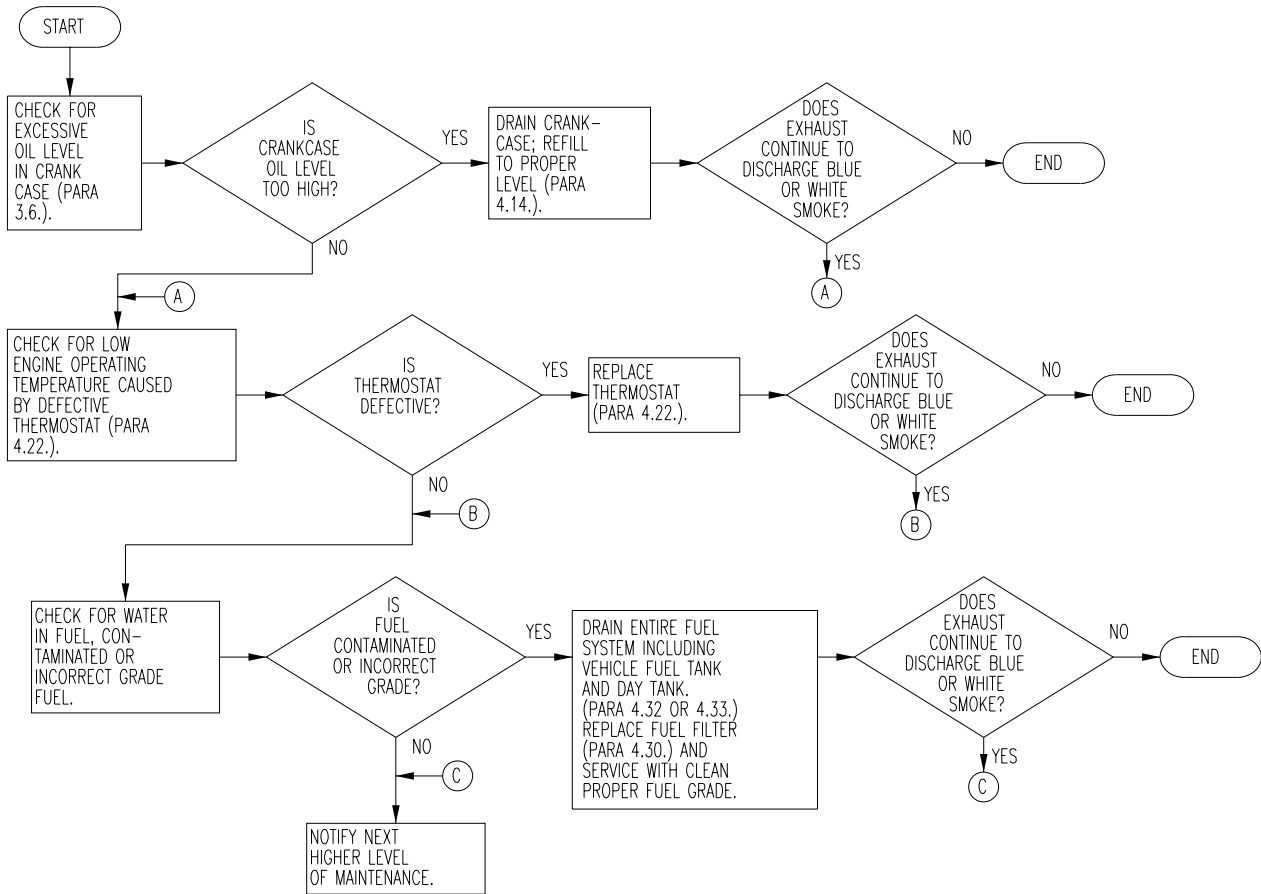

10. LOW OIL PRESSURE.

STEP 1. Extract oil sample from engine and send it to Army Oil Analysis Program (AOAP) Lab for analysis. Follow recommendations of AOAP Lab, if applicable. If no AOAP Lab is available replace oil and oil filter (para 4.15.). Refill crankcase with proper viscosity oil. Check oil pressure after changing oil.

- a. If the oil pressure is within normal operating pressure, problem is resolved.
- b. If the oil pressure is low, proceed to step 2.

STEP 2. Check for faulty oil pressure sending unit.

- a. If oil pressure sending unit is defective, replace oil pressure sending unit.
- b. If oil pressure sending unit is functioning properly, proceed to step 3.

STEP 3. Check for loose or broken wires between oil pressure sending unit and control circuits.

- a. If the wires are broken or loose, repair as required, and retest for low oil pressure.
- b. If there is a good connection between the oil pressure sending unit and the control circuit, notify next higher level of maintenance.

11. ENGINE OVERHEATING.

STEP 1. Check for adequate coolant in radiator overflow tank, and after engine cools check for adequate coolant in radiator (para 4.19.).

- a. If radiator overflow tank or radiator is low in coolant, fill with additional coolant.
- b. If there is adequate coolant in tank or radiator, proceed to step 2.

STEP 2. Check for blocked, clogged or dirty radiator, exhaust pipe, muffler or vehicle APU compartment doors and vents.

- a. If radiator, exhaust pipe, muffler or vehicle APU compartment doors and vents are blocked, clogged or dirty, clean until adequate air flows through APU compartment, muffler, exhaust pipe and radiator.
- b. If radiator, exhaust pipe, muffler or vehicle or compartment doors and vents are clean and air flow freely, proceed to step 3.

STEP 3. Check for defective radiator cap (para 5.11.).

- a. If the radiator cap is defective, replace cap.
- b. If the radiator cap is functioning properly, proceed to step 4.

STEP 4. Check for defective thermostat (para 4.22.).

- a. If the thermostat is defective, replace thermostat.
- b. If the thermostat is not defective, proceed to step 5.

STEP 5. Check for defective fan belt (para 4.23.).

- a. If fan belt is loose, worn or defective, ADJUST or REPLACE belt (para 4.23.).
- b. If fan belt is functioning properly, proceed to step 6.

STEP 6. Inspect for collapsed or defective radiator hoses (para 4.24.).

- a. If radiator hoses are worn, collapsed or defective, REPLACE hoses (para 4.24.).
- b. If radiator hoses are functioning properly, proceed to step 7.

STEP 7. Check fuel filter sediment container for water or other contaminants in the fuel, incorrect grade or fuel type.

- a. If the fuel is contaminated, drain entire fuel system including vehicle fuel tank and APU day tank (para 4.32. or 4.33.). Replace fuel filter (para 4.30.). Service with clean fuel. Bleed fuel system.
- b. If the fuel is uncontaminated, notify next higher level of maintenance.

12. ENGINE COOLANT TEMPERATURE TOO LOW.

STEP 1. Check for proper antifreeze/water mixture ratio in radiator overflow tank and in radiator.

- a. If the antifreeze/water mixture ratio is incorrect, add water or antifreeze as required.
- b. If the antifreeze/water mixture ratio is correct, proceed to step 2.

STEP 2. Check for defective thermostat (para 4.22.).

- a. If thermostat is defective, replace thermostat.
- b. If thermostat is functioning properly, proceed to step 3.

STEP 3. Check for defective temperature sender (para 4.25.).

- a. If the temperature sender is defective, replace sender.
- b. If the temperature sender is functioning properly, notify next higher level maintenance.

13. DC AMMETER SHOWS NO CHARGE WHEN VEHICLE BATTERY IS LOW OR DISCHARGED.

STEP 1. Check for broken wires, and loose or corroded electrical connections.

- a. If wires are broken or loose, repair the wires, remove the corrosion and tighten the connections.
- b. If the wires are not broken and connections are tight and clean, proceed to step 2.

STEP 2. Check for broken, worn or loose fan belt (para 4.23.).

- a. If fan belt is broken, worn or loose replace fan belt.
- b. If fan belt is not defective, proceed to step 3.

STEP 3. Check for defective alternator (para 4.36.).

- a. If the alternator is defective, replace alternator.
- b. If the alternator is not defective, proceed to step 4.

STEP 4. Check for defective battery charging meter.

- a. If the battery charging meter is defective, replace battery charging meter.
- b. If the battery charging meter is functioning properly, notify next higher level maintenance.

14. DC AMMETER SHOWS EXCESSIVE CHARGING AFTER PROLONGED APU OPERATION.

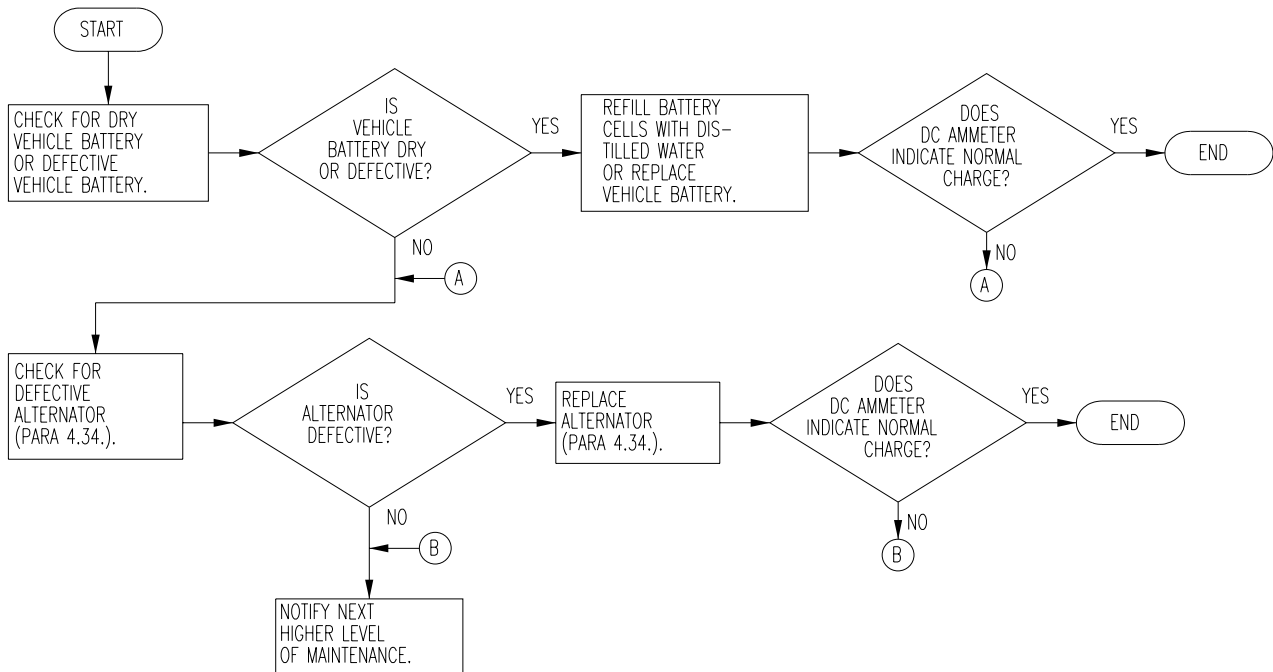

15. EXCESSIVE OIL CONSUMPTION.

STEP 1. Check for oil leak from oil filter, drain plug, oil cooler and valve cover.

- a. If oil leak is present, repair oil leak by tightening oil filter or plug (para 4.15.), tightening oil cooler mounting tube (para 4.16.) or repair/replacement of defective parts.
- b. If no oil leak is detected, notify next higher level of maintenance.

16. HIGH OIL PRESSURE.

STEP 1. Check for proper viscosity oil in engine.

- a. If improper viscosity oil is found in engine, change oil and filter (para 4.15.).
- b. If the improper viscosity oil is in engine, notify next higher level of maintenance.

17. FUEL MIXED INTO LUBRICANT OIL.

Notify Next Higher Level of Maintenance.

18. COOLANT MIXED INTO LUBRICANT OIL.

Notify Next Higher Level of Maintenance.

19. AC VOLTMETER DOES NOT INDICATE VOLTAGE.

Notify Next Higher Level of Maintenance.

20. AC VOLTMETER INDICATES VOLTAGE BUT FREQUENCY METER IS OFF SCALE.

Notify Next Higher Level of Maintenance.

21. AC VOLTAGE FLUCTUATES.

Notify Next Higher Level of Maintenance.

22. FREQUENCY FLUCTUATES.

Notify Next Higher Level of Maintenance.

23. MAIN AC CONTACTOR WILL NOT CLOSE.

Notify Next Higher Level of Maintenance.

24. OIL PRESSURE FAULT INDICATOR LIGHTS.

See Symptom 10.

25. WATER TEMP FAULT INDICATOR LIGHTS.

See Symptom 11.

26. OVERSPEED FAULT INDICATOR LIGHTS.

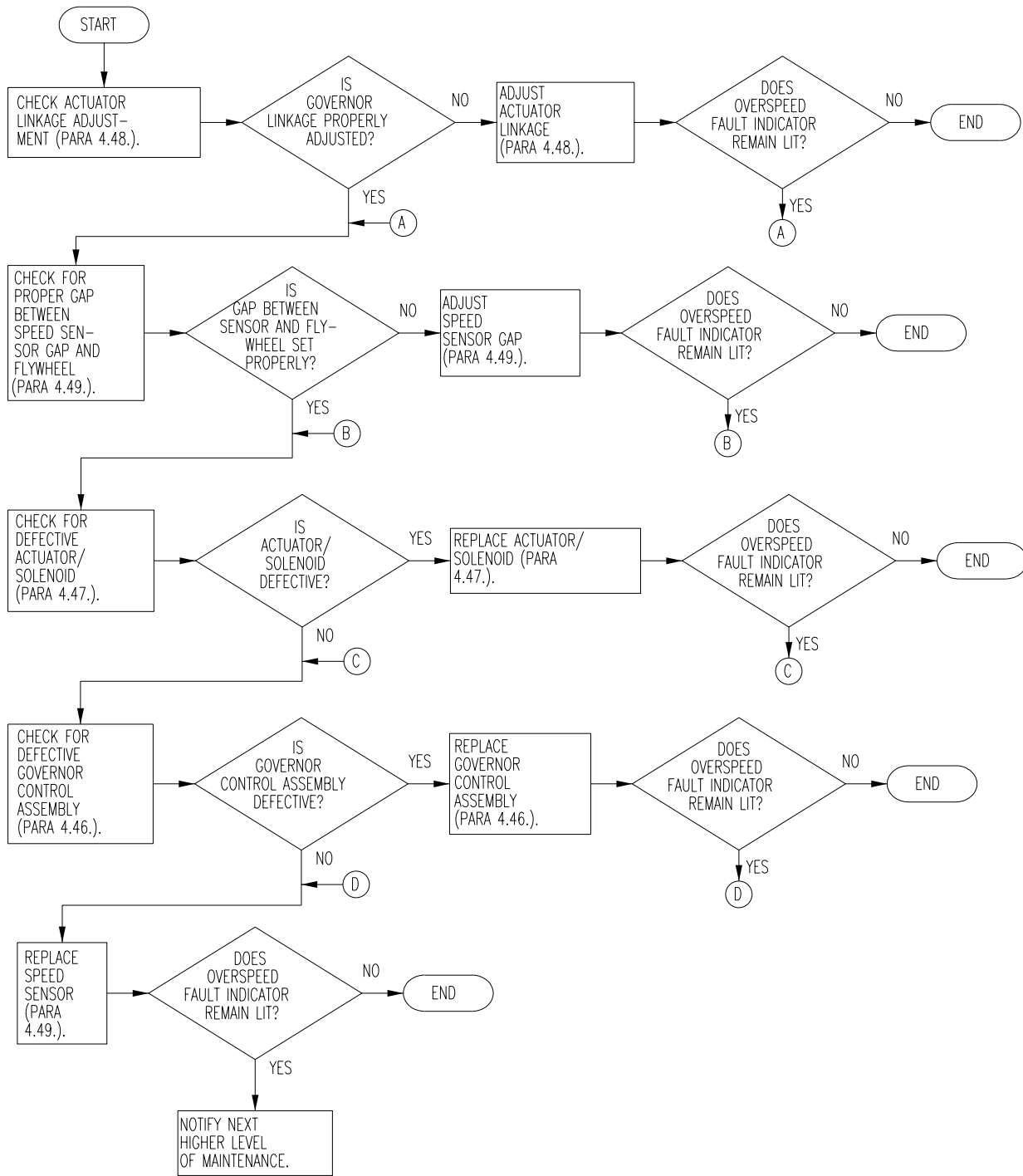

27. OVER-VOLTAGE FAULT INDICATOR LIGHTS.

Notify Next Higher Level of Maintenance.

Section VII. PREPARATION FOR STORAGE OR SHIPMENT**4.12. PREPARATION FOR STORAGE OR SHIPMENT.**

To prepare the APU for storage or shipment proceed as follows:

- a. Perform APU normal shutdown procedures (para 2.6.).
- b. If APU is to be shutdown for up to six months, replace engine oil (para 4.14.) and drain fuel from the fuel tank (para 4.32. or para 4.33.).
- c. If APU is to be shutdown for up to twelve months, perform step b, then drain engine coolant (para 4.19.).

4.13. SPECIAL INSTRUCTIONS FOR ADMINISTRATIVE STORAGE.

Placement of equipment in administrative storage should be for short periods of time when shortage of maintenance effort exists. Items should be in mission readiness within 24 hours or within the time factors as determined by the directing authority. During the storage period, appropriate maintenance records shall be kept.

Before placing the equipment in administrative storage, current preventive maintenance checks and services should be completed, shortcomings and deficiencies should be corrected, and all Modification Work Orders (MWO) should be applied.

Storage site selection. Inside storage is preferred for items selected for administrative storage. If inside storage is not available, trucks, vans, CONEX containers, and other containers may be used.

Section VIII. UNIT MAINTENANCE INSTRUCTIONS

4.14. ENGINE OIL.

This task covers: Service

INITIAL SETUP

Tools

General Mechanic's Tool Kit
(Item 1, Appendix B)

Equipment Conditions

Engine warmed for five minutes and stopped.

Materials/Parts

Four Quarts (3.8 liters) Engine Oil

NOTE

Change the type of engine oil according to the ambient temperature (see Table 3-1).

SERVICE

NOTE

Collect oil in an appropriate chemical resistant container for disposition/disposal through the local servicing Defense Reutilization and Marketing Office.

- a. Remove drain plug (1, Figure 4-1) at the bottom of the engine.
- b. Allow oil to drain off completely.
- c. Replace oil filter (para 4.15.).

NOTE

Always replace oil filter (para 4.15.) when changing engine oil.

- d. Reinstall drain plug (1).
- e. Replace engine oil (para 3.6.).

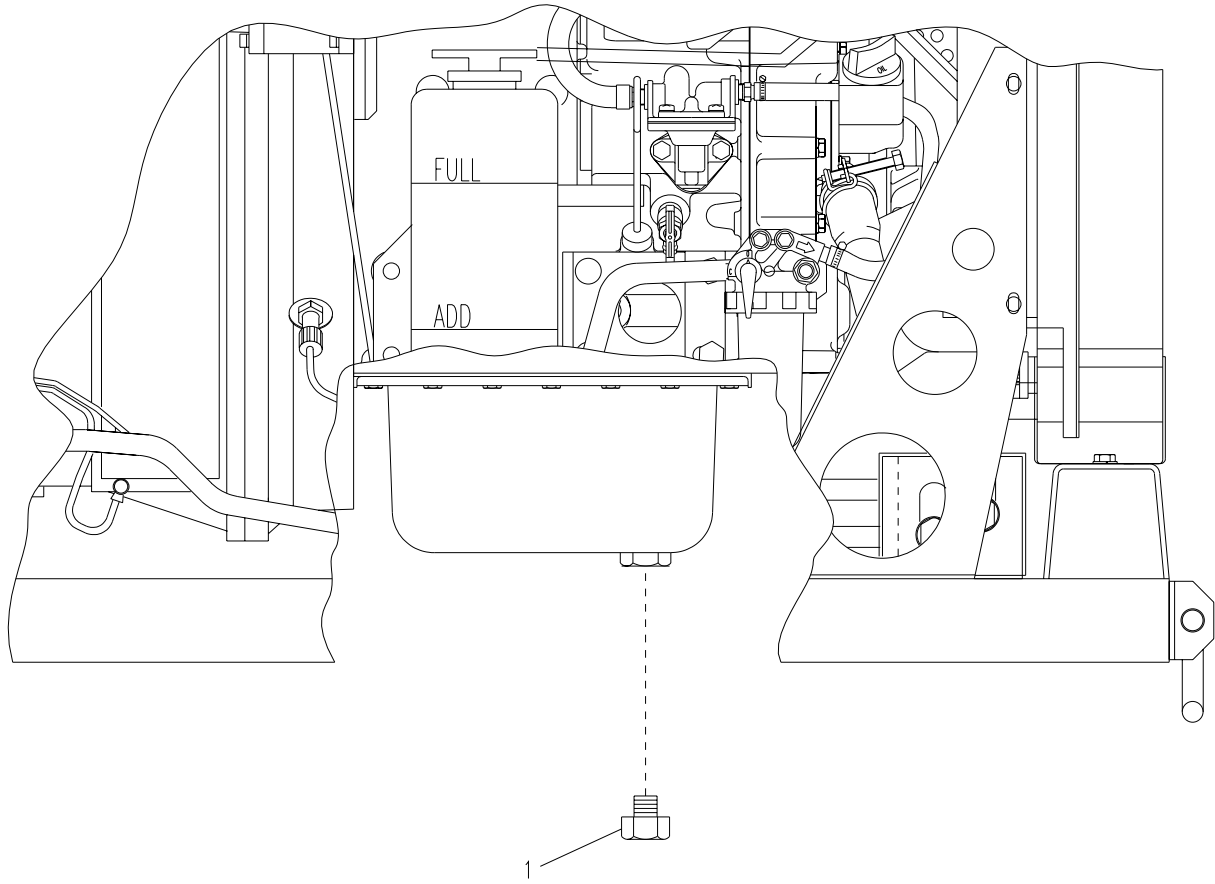

Figure 4-1. Engine Oil

4.15. OIL FILTER.

This task covers: Replace

**INITIAL
SETUP**

Tools

None

Equipment Conditions

MASTER ON-OFF switch on APU Control Unit set to OFF.

Materials/Parts

Oil Filter

Oil drained from engine crankcase (para 4.14.).

REPLACE

NOTE

Oil filter is located on the fuel pump side or SICPS and WIN-T units. Oil filter is located on the muffler side for JTACS unit.

- a. Unscrew oil filter (2, Figure 4-2) by turning counter clockwise.
- b. Remove oil filter from oil cooler (1).
- c. Lubricate gasket on new oil filter with engine oil.

CAUTION

Do not overtighten new oil filter. Overtightening may damage oil filter gasket.

- d. Install new oil filter (2) on oil cooler (1) and hand tighten by turning clockwise (cw).
- e. Replenish oil (para 3.6.).

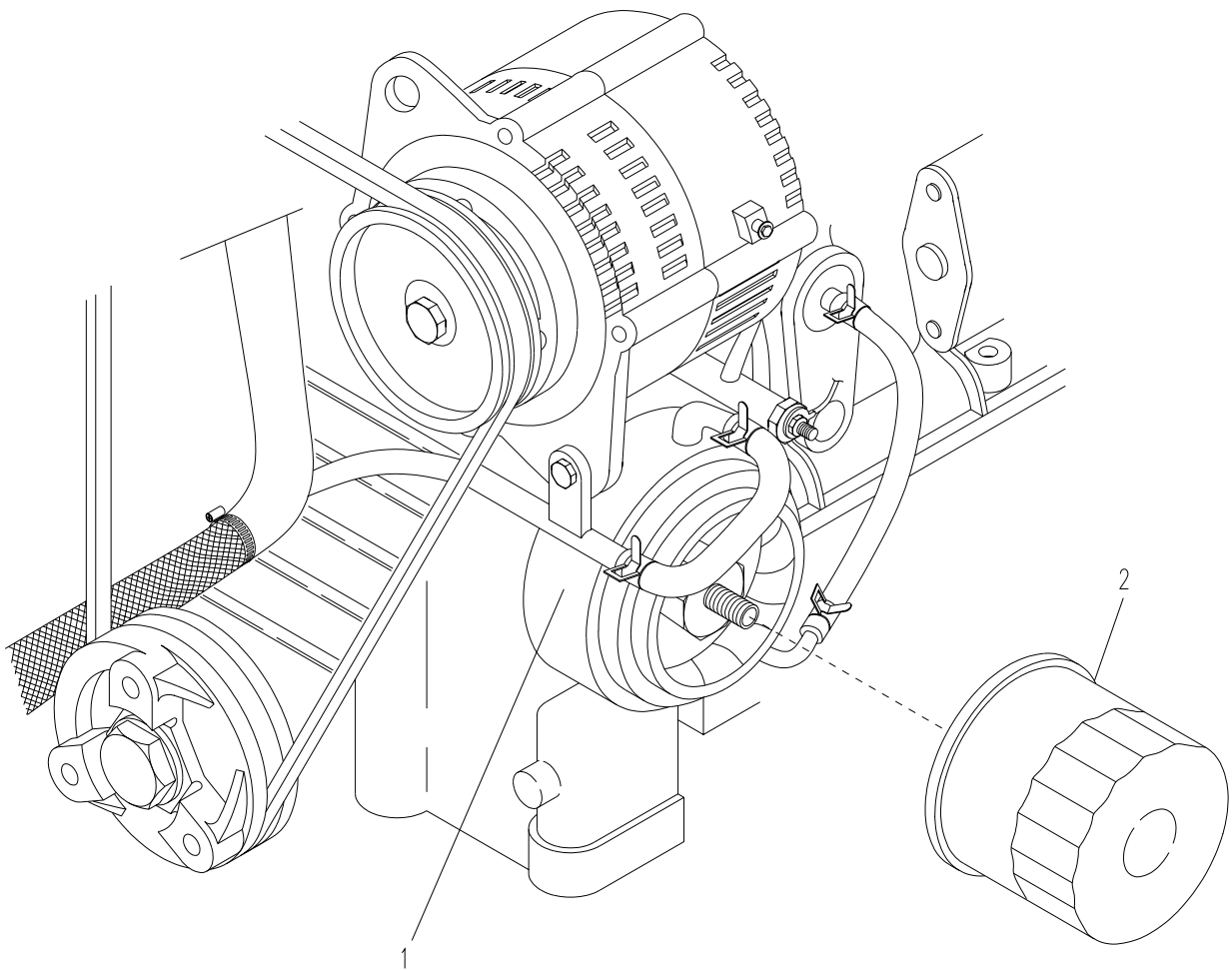

Figure 4-2. Oil Filter

4.16. OIL COOLER.

This task covers: a. Inspect b. Replace

INITIAL SETUP

Tools

General Mechanic's Tool Kit
(Item 1, Appendix B)

Equipment Conditions

MASTER ON-OFF switch on APU controller set to OFF.

Materials/Parts

Oil Cooler
Packing, Oil Cooler
(Item 8, Appendix J)
Spacer

Oil filter removed (para 4.15.).

INSPECT

- a. Inspect water hoses (5, Figure 4-3) and (8) for loosening or deterioration. If loosening or deterioration is present, replace water hoses.
- b. Inspect for leakage from packing (2) behind oil cooler (3). Replace if leakage is present.

REPLACE

NOTE

When removing water hoses and oil cooler, have suitable container available to receive coolant spillage. Collect coolant in an appropriate chemical resistant container for disposition/disposal through the local servicing Defense Reutilization and Marketing Office.

- a. Loosen two clamps (4) and remove upper water hose (5) from oil cooler (3).
- b. Loosen one clamp (4) and remove lower water hose (8) from oil cooler (3).
- c. Remove oil filter mount (6) from engine block (9).
- d. Remove oil cooler (3), packing (2), and spacer (1).
- e. Inspect packing (2) and replace if deteriorated.
- f. Install new spacer (1), packing (2), and oil cooler (3) on oil filter mount (6) and install mount on engine block (9).
- g. Replace upper water hose (5) and two clamps (4).
- h. Replace lower water hose (8) and one clamp (4).
- i. Replenish coolant (para 3.8.).

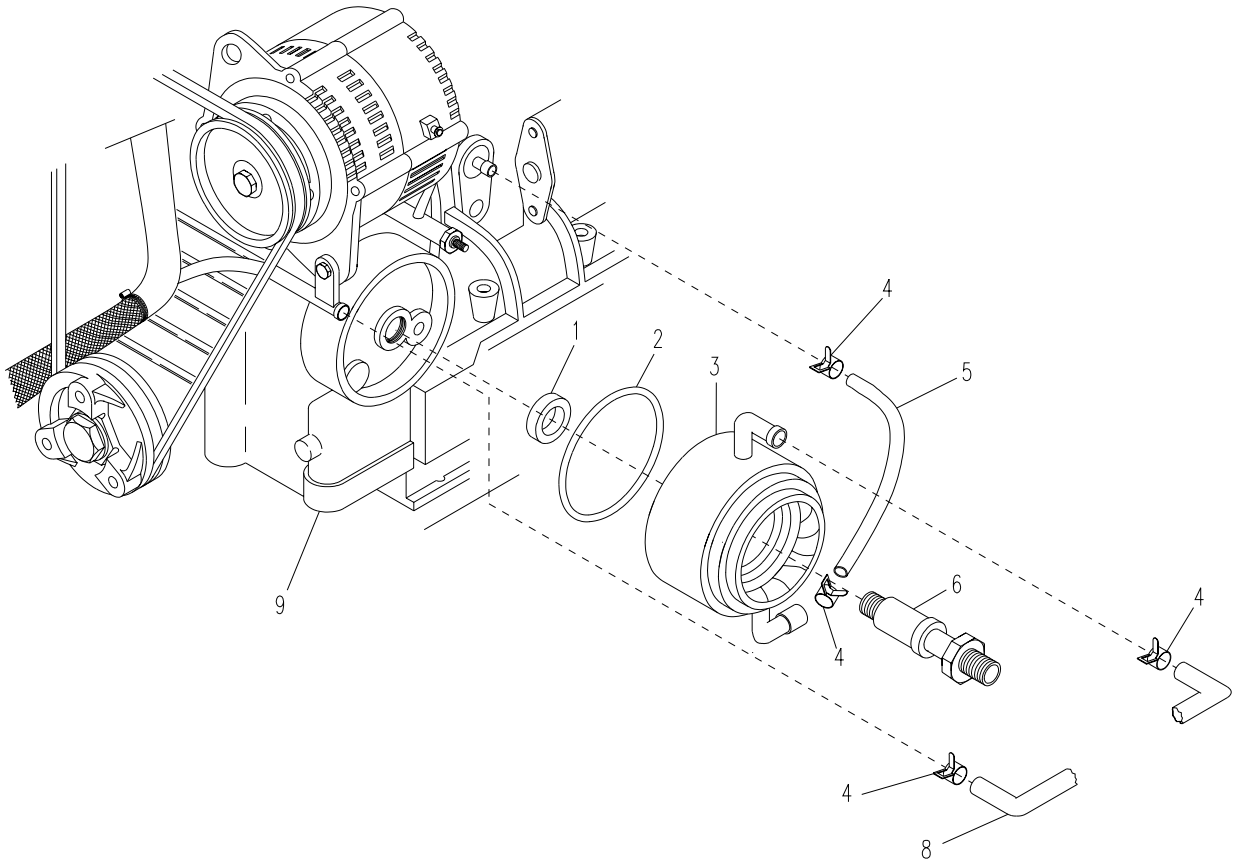

Figure 4-3. Oil Cooler

4.17. LOW OIL PRESSURE SWITCH.

This task covers: a. Test b. Replace

INITIAL SETUP

Tools

General Mechanic's Tool Kit
(Item 1, Appendix B)

Shop Equipment,
Electrical Repair, Semitrailer Mounted
(Item 3, Appendix B)

Materials/Parts

Low Oil Pressure Switch
Sealing Compound
(Item 17, Appendix F)

Equipment Conditions

MASTER ON-OFF switch on APU control unit set to OFF.

TEST

- a. Remove one screw and lock washer (3, Figure 4-4 (sheet 1)) securing lead (2) to low oil pressure switch (1). Retain hardware.
- b. Tag and remove lead (2) from low oil pressure switch (1).
- c. Connect one multimeter lead to low oil pressure switch (1) post, and connect the other multimeter lead to ground. If continuity is observed, proceed to step d. If not, replace low oil pressure switch.
- d. Install lead (2) on low oil pressure switch (1).
- e. Secure lead with one lock washer and screw (3).
- f. On APU control unit, position MASTER ON-OFF switch to ON. Low oil pressure fault indicator on control unit should light.
- g. Start APU (para 2.5.). After a few seconds, fault indicator should go out as engine oil pressure builds past 7 psig (48.26 kPa).
- h. If low oil pressure fault indicator on APU control unit remains lit, shut down the APU (para 2.6) and replace low oil pressure switch.

REPLACE

NOTE

When removing low oil pressure switch, have suitable container available to receive oil spillage. Collect oil in an appropriate chemical resistant container for disposition/disposal through the local servicing Defense Reutilization and Marketing Office.

- a. Remove one screw and lock washer (3, Figure 4-4 (sheet 2)). Retain hardware.
- b. Tag and remove lead (2) from low oil pressure switch (1).
- c. Remove low oil pressure switch (1) from engine.

- d. Apply sealing compound to threads of new low oil pressure switch.
- e. Install new low oil pressure switch (1) into engine.
- f. Install lead (2) on low oil pressure switch (1) post using one lock washer and screw (3).

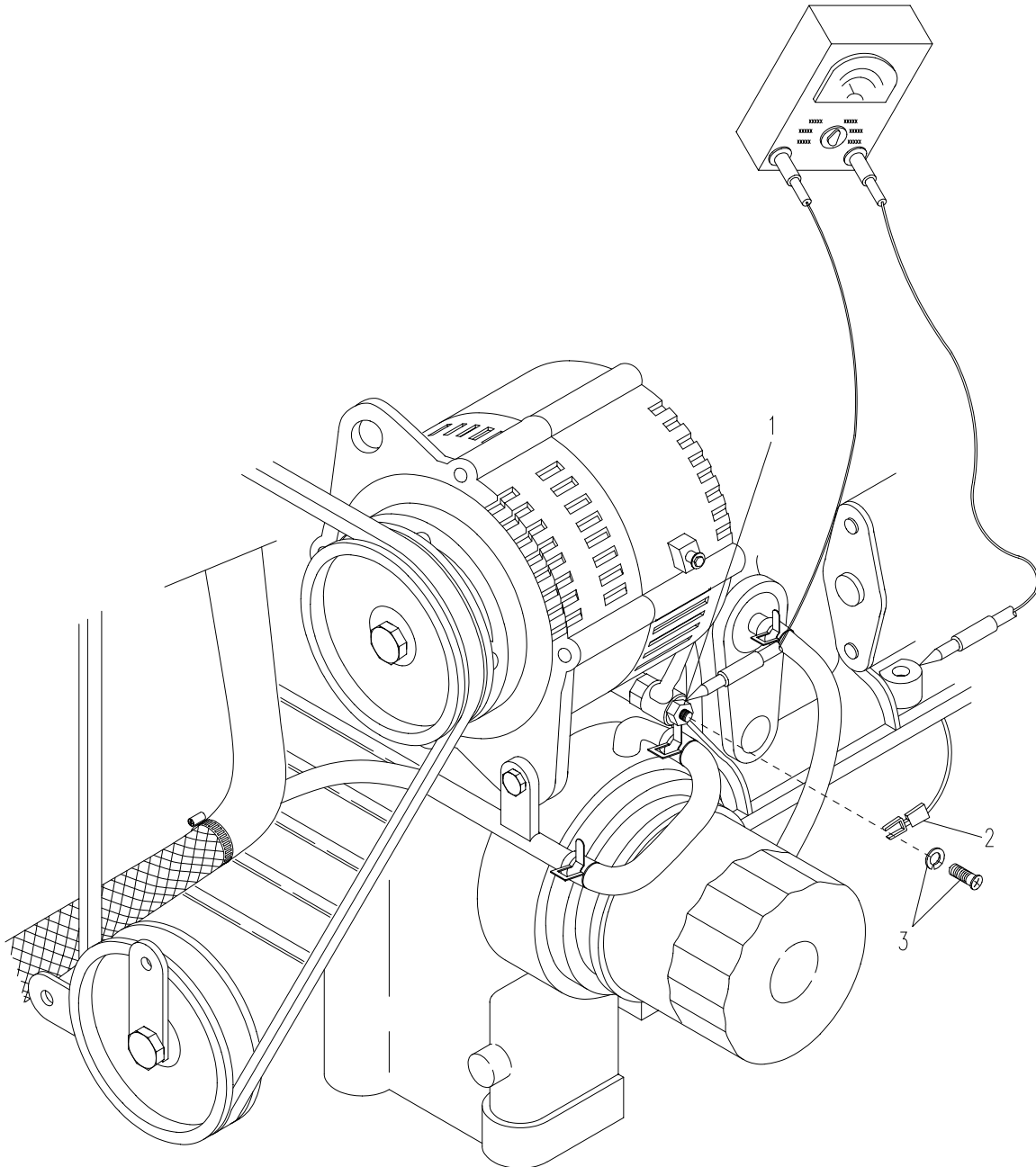

Figure 4-4. Low Oil Pressure Switch (Sheet 1 of 2)

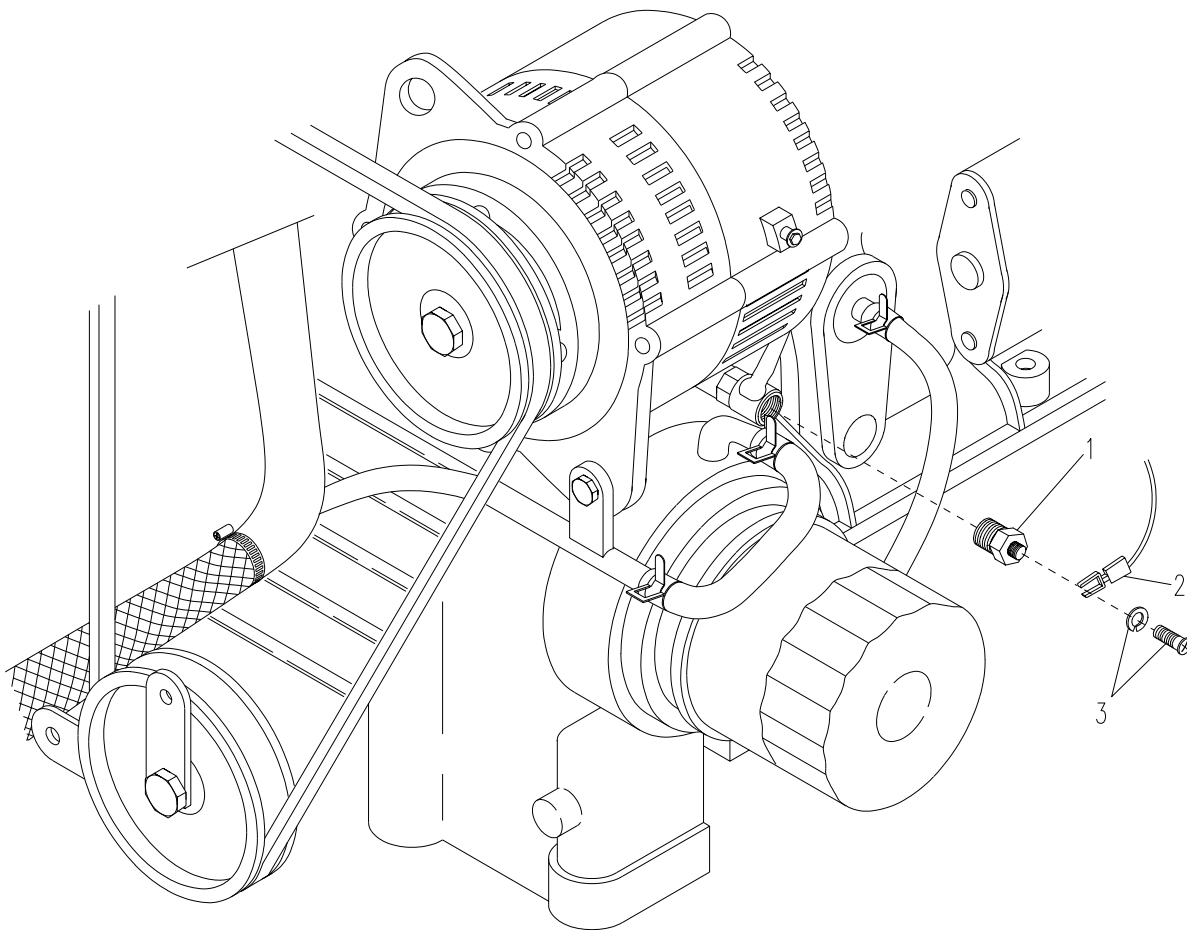

Figure 4-4. Low Oil Pressure Switch (Sheet 2)

4.18. FAN GUARD, FAN SHROUD, AND SHROUD HOUSING.

This task covers: a. Adjust b. Removal c. Replace

INITIAL SETUP

Tools

General Mechanic's Tool Kit
(Item 1, Appendix B)

Equipment Conditions

MASTER ON-OFF switch set to OFF.

Materials/Parts

Fan Guard, Fan Shroud, Shroud Housing

WARNING

DO NOT operate APU with radiator hose or fan guard removed. Failure to heed this warning could result in injury to personnel or damage to equipment.

ADJUST

- a. Loosen screws and washers (8, 19, Figure 4-5 (Sheet 2)) securing fan shroud (10) to shroud housing (12).
- b. Adjust shroud so that fan blade is in center of shroud (10). Tighten hardware.

REMOVE

- a. Remove two screws and flat washers (1, Figure 4-5), and two lock washers and nuts (3) from resilient mount bracket support (7) and radiator flange bracket (2).
- b. Remove two bolts and flat and lock washers (5) from generator bracket (6) and air deflector shield (4).
- c. Remove resilient mount bracket support (7) and generator bracket (6).
- d. Remove two screws, flat and lock washers (15, Figure 4-5 (sheet 2)), two screws (JTACS) or two slotted hex-head screws (SICPS, WIN-T) and flat and lock washers (17), and radiator support bracket (16).
- e. Loosen two clamps (13) and remove upper radiator hose (14).
- f. Remove four screws and washers (8) and fan guard (9).
- g. Remove two screws and washers (19) and fan shroud (10).
- h. Remove four screws (JTACS) or four slotted hex-head screws (SICPS, WIN-T) and flat and lock washers (11) from left and right halves of shroud housing (12).
- i. Remove six screws (JTACS) or six slotted hex-head screws (SICPS, WIN-T) and flat and lock washers (18) and left and right halves of shroud housing (12).

REPLACE

- a. Install left and right halves of shroud housing (12) and six screws (JTACS) or six slotted hex-head screws (SICPS, WIN-T) and flat and lock washers (18).
- b. Secure left and right halves of shroud housing (12) by installing four screws (JTACS) or six slotted hex-head screws (SICPS, WIN-T) and flat and lock washers (11).
- c. Install fan shroud (10) and secure by installing two screws and washers (19) into lower two mounting holes.
- d. Install fan guard (9) and secure with four screws and washers (8).
- e. Install upper radiator hose (14) and secure with two clamps (13).
- f. Install radiator support bracket (16) and secure with two screws and flat and lock washers (15), and two screws (JTACS) or two slotted hex-head screws (SICPS, WIN-T) and flat and lock washers (17).
- g. Install resilient mount bracket support (7, Figure 4-5 (sheet 1)), two screws and flat washers (1), and two nuts and lock washers (3).
- h. Install generator bracket (6) on air deflector shield (4) and two bolts and flat and lock washers (5).
- i. Secure resilient mount bracket support (7) to radiator flange bracket (2) with two screws and flat washers (1) and two lock washers and nuts (3).

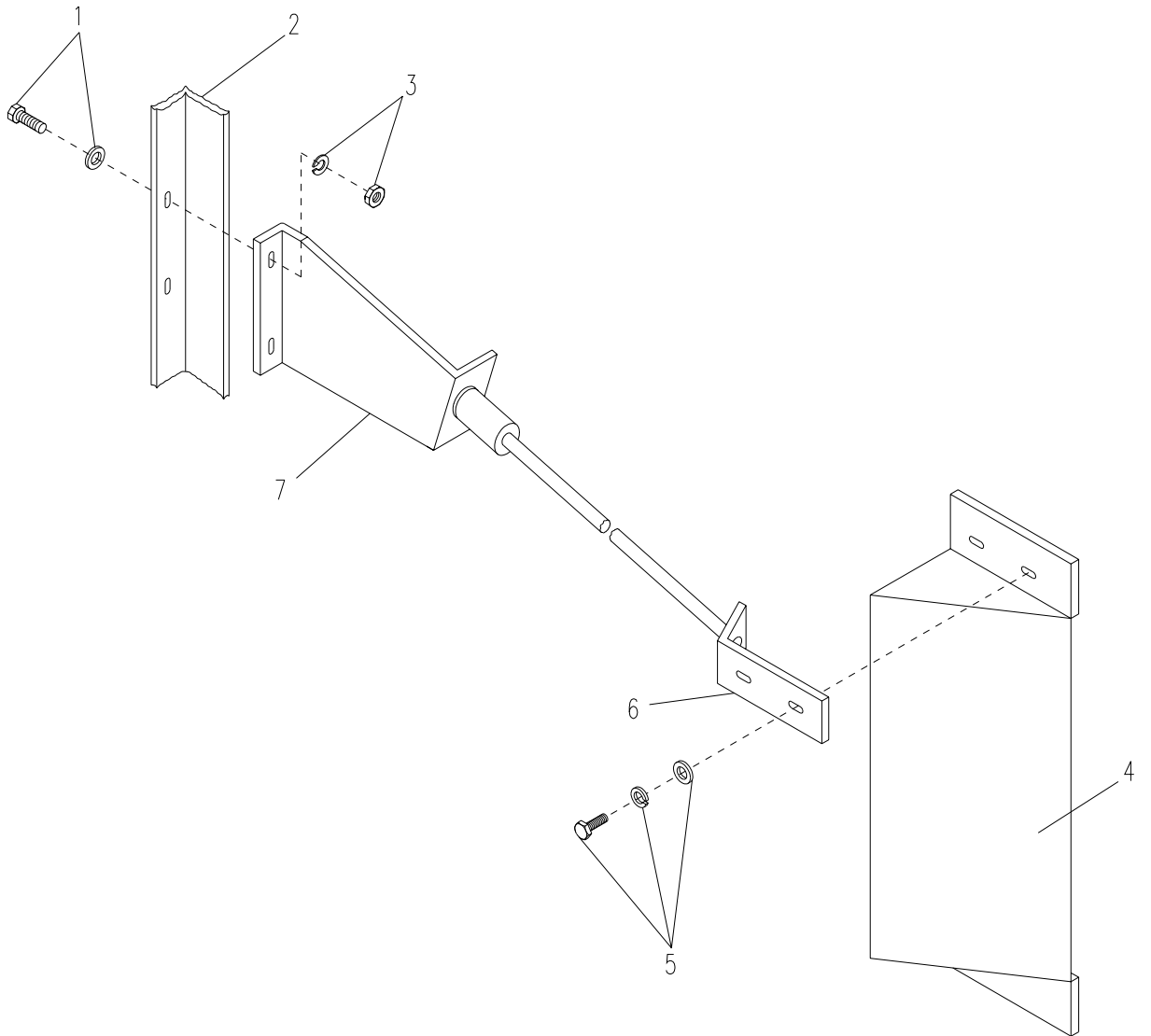

Figure 4-5. Fan Guard, Fan Shroud, and Shroud Housing (Sheet 1 of 2)

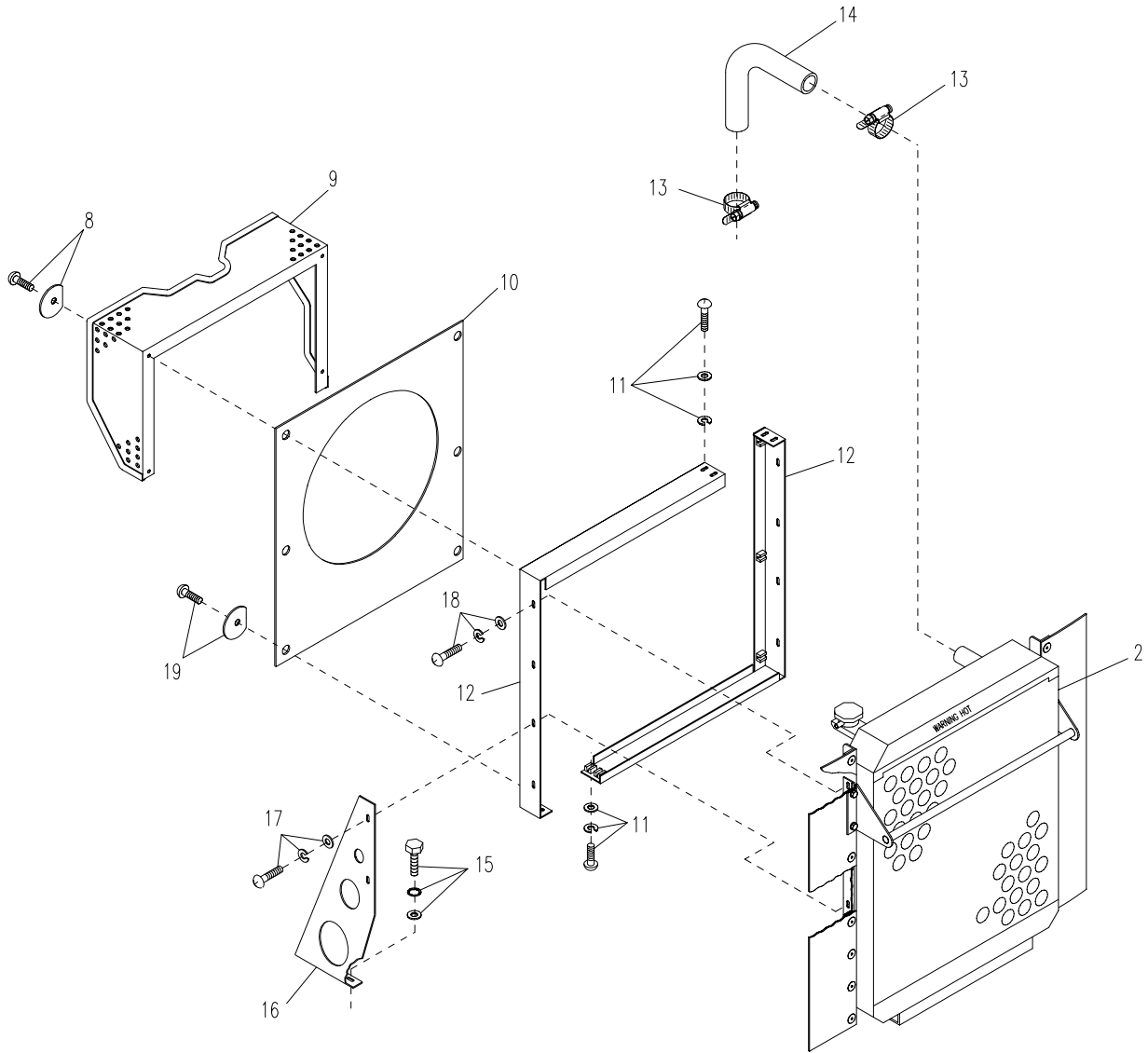

Figure 4-5. Fan Guard, Fan Shroud, and Shroud Housing (Sheet 2)

4.19. RADIATOR SUB-ASSEMBLY.

This task covers: a. Inspect b. Service c. Test d. Repair e. Replace

INITIAL SETUP

Tools

General Mechanic's Tool Kit
(Item 1, Appendix B)

Radiator Tester
(Item 7, Appendix B)

Materials/Parts

Radiator

Sealing Compound
(Item 19, Appendix F)

Antifreeze
(Item 1, Appendix F)

Equipment Condition

Engine stopped and allowed to cool completely.

MASTER ON-OFF switch on APU control unit set to OFF.

Fan Shroud removed.

INSPECT

Visually inspect radiator for leakage or signs of physical damage.

SERVICE

WARNING

Hot coolant is under pressure. Do not remove radiator cap when engine is hot. Allow engine to cool completely before removing radiator cap. Once cooling has occurred, loosen cap slightly to relieve any excess pressure before removing the cap completely. Failure to observe this warning will result in severe injury to personnel.

- a. Loosen two clamps and remove wrap from exhaust pipe on muffler.
- b. Remove radiator cap (para 3.7.).

NOTE

Place a suitable container under radiator drain valve and engine drain valve to catch waste coolant. Collect coolant in an appropriate chemical resistant container for disposition/disposal through the local servicing Defense Reutilization and Marketing Office.

- c. Open drain valve (1, Figure 4-6) under radiator sub-assembly (2) and allow coolant to drain completely.

- d. Open drain valve (4, Figure 4-6 (sheet 2)) on engine block (3) and allow remaining coolant to drain completely.
- e. Flush radiator with clean water to remove rust buildup.
- f. Remove radiator overflow tank (para 4.28.) and radiator overflow hose (para 4.24.).
- g. Empty coolant from radiator overflow tank and radiator overflow hose and rinse with clean water.
- h. Fill radiator overflow tank with clean water and proper antifreeze mix to halfway between "full" and "low" marks (para 3.8.).
- i. Install radiator overflow tank (para 4.28.) and radiator overflow hose (para 4.24.).
- j. Close radiator drain valve (1) and engine drain valve (4).
- k. Fill radiator with coolant slowly until full.
- l. Install radiator cap (para 3.7.).

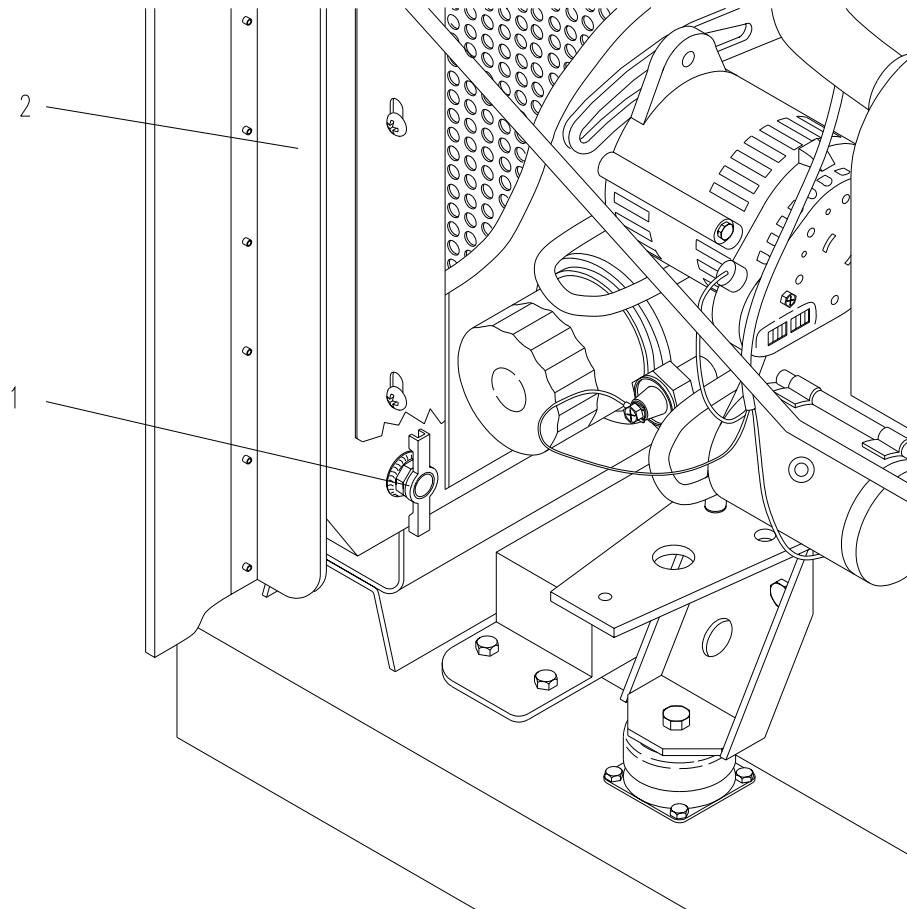

Figure 4-6. Radiator (Sheet 1 of 3)

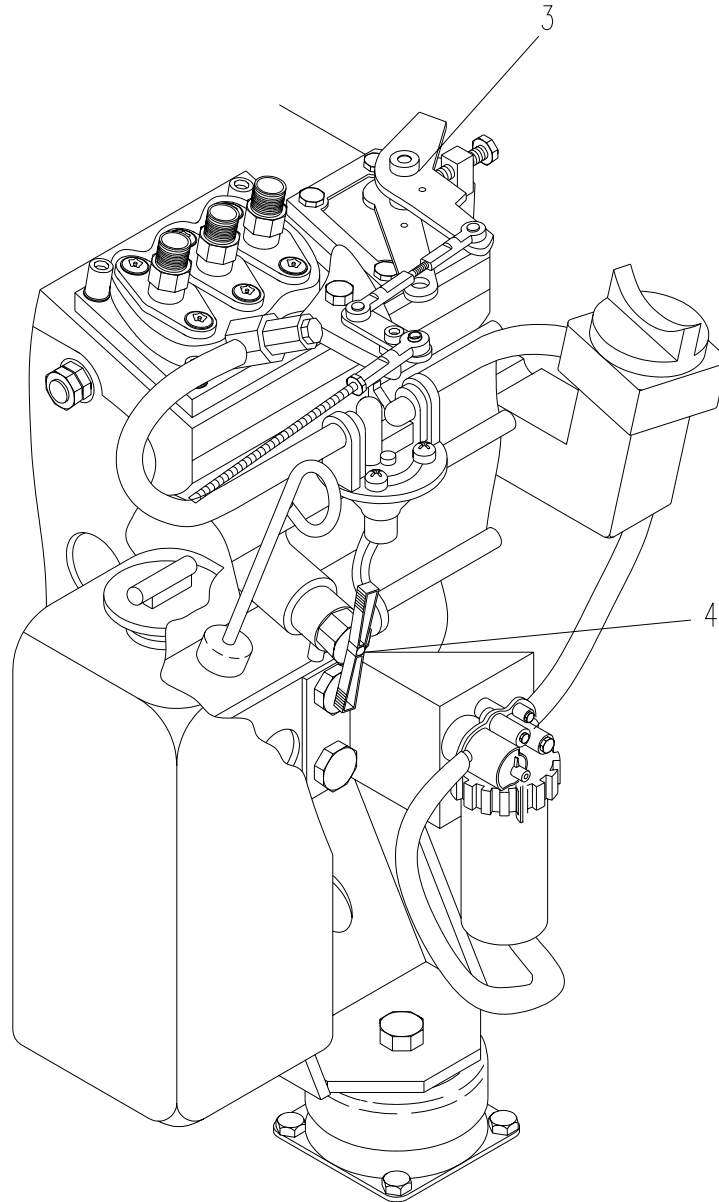

Figure 4-6. Radiator (Sheet 2)

TEST

- a. Check that radiator sub-assembly has sufficient coolant (para 3.8.).
- b. Start APU (para 2.5.), warm up the engine, then shut it down (para 2.6.).

WARNING

Hot coolant is under pressure. Do not remove radiator cap when engine is hot. Allow engine to cool completely before removing radiator cap. Once cooling has occurred, loosen cap slightly to relieve any excess pressure before removing the cap completely. Failure to observe this warning could result in burns or injury to personnel.

- c. After coolant has cooled sufficiently to open the radiator cap safely, but is still warm, remove the radiator cap and install radiator tester.
- d. Raise the water pressure to 23 PSI (158.58 kPa) and check for leaks.
- e. If pinhole size leaks are observed, repair with sealing compound. If leaks are excessive, replace radiator.

REPAIR

Refer to para 4.20., Radiator Coolant Drain Valve, for repair of radiator sub-assembly.

REPLACE

- a. Drain coolant from radiator subassembly (para 4.19.).
- b. Remove radiator hoses (para 4.24.).
- c. Remove fan guard, shroud housing, and fan shroud (para 4.18.).
- d. Remove two nuts and flat washers (2, Figure 4-6), two rubber washers (3), and two bolts and lock washers (4) securing radiator (1) to radiator mount (5). Remove radiator (1).
- e. Install new radiator (1) on radiator mount (5) and secure with two bolts and two flat washers, two lock washers and nuts (4), two rubber washers (3), and two nuts and flat washers (2).

- f. Install fan guard, shroud housing, and fan shroud (para 4.18.).
- g. Install radiator hoses (para 4.24.).
- h. Service radiator with coolant (para 4.19.).

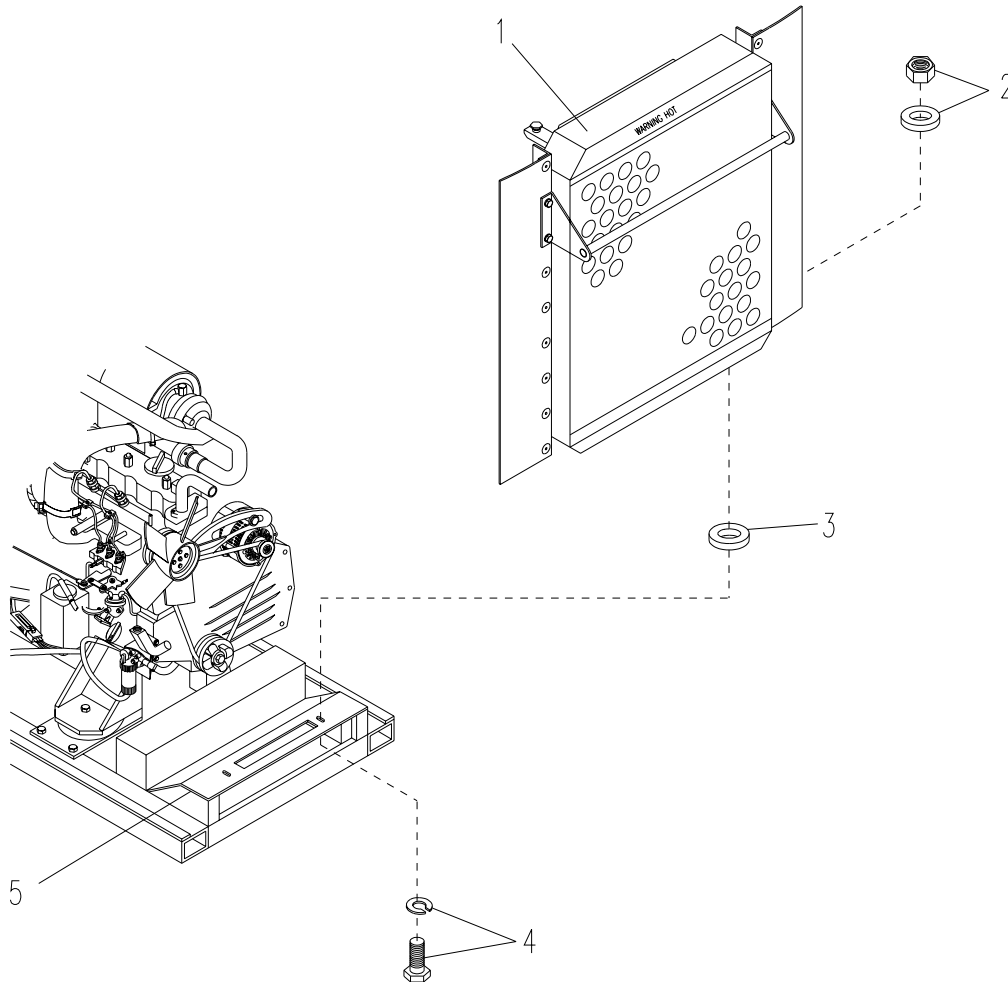

Figure 4-6. Radiator (Sheet 3)

4.20. RADIATOR COOLANT DRAIN VALVE.

This task covers: Replace

INITIAL SETUP

Tools

General Mechanic's Tool Kit
(Item 1, Appendix B)

Materials/Parts

Radiator Coolant Drain Valve

Sealing Compound
(Item 18, Appendix F)

Equipment Conditions

Engine stopped and allowed to cool completely.

MASTER ON-OFF switch on APU controller set to OFF.

Coolant drained (para 4.19.).

REPLACE

- a. Remove coolant drain valve (3, Figure 4-7) and lock nut (2) by turning ccw.
- b. Clean all old sealing compound from threads in drain hole (1).
- c. Apply sealing compound to threads on coolant drain valve (3).
- d. Install lock nut (2) and drain valve (3).

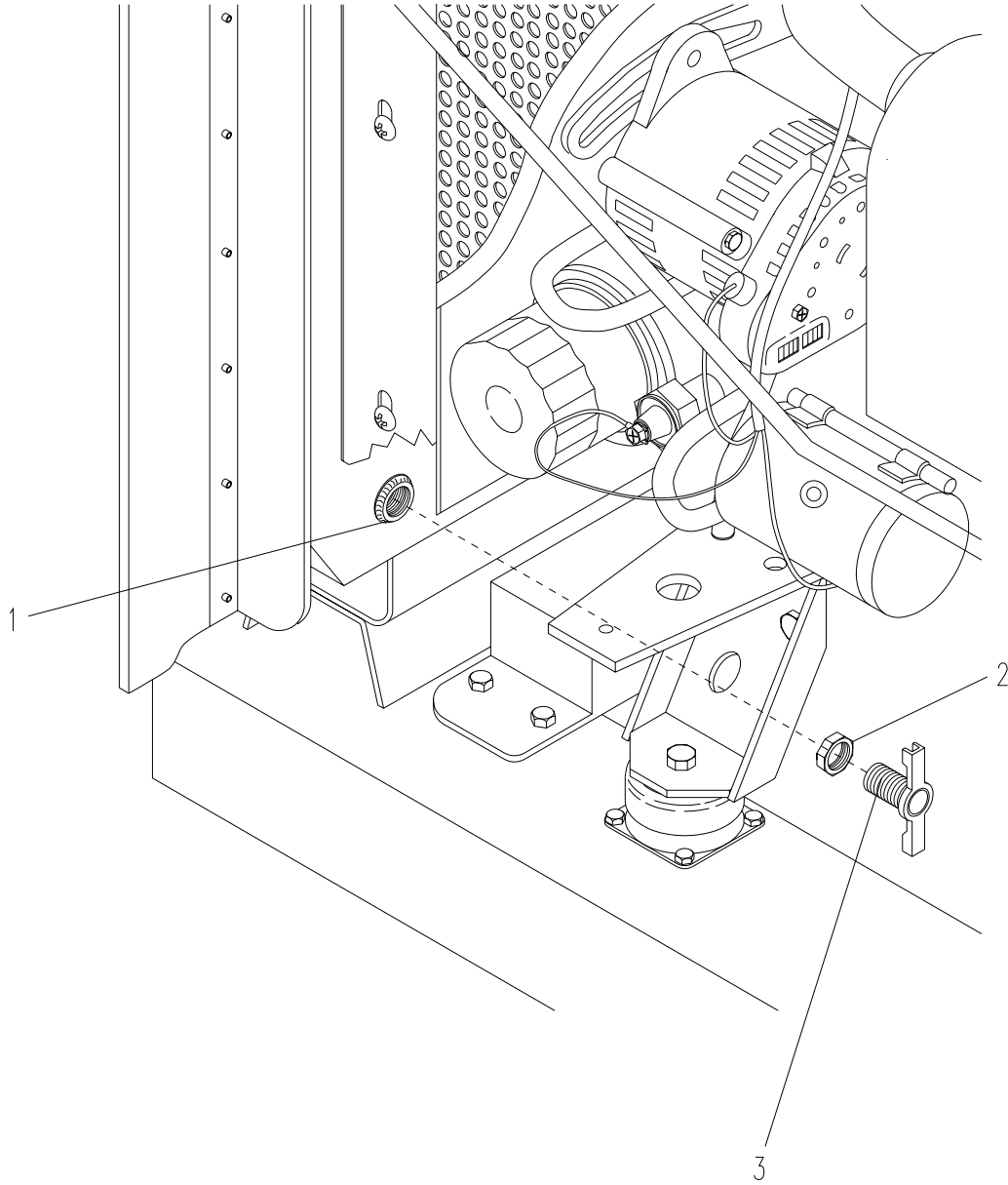

Figure 4-7. Radiator Coolant Drain Valve

4.21. ENGINE COOLANT DRAIN VALVE.

This task covers: Replace

INITIAL SETUP

Tools

General Mechanic's Tool Kit
(Item 1, Appendix B)

Materials/Parts

Engine Coolant Drain Valve

Sealing Compound
(Item 18, Appendix F)

Equipment Conditions

Engine stopped and allowed to cool completely.

MASTER ON-OFF switch on APU controller set to OFF.

Coolant drained (para 4.19.).

REPLACE

- a. Remove coolant drain valve (2, Figure 4-8) by turning ccw.
- b. Clean all old sealing compound from threads in engine drain hole (1).
- c. Apply sealing compound to threads on coolant drain valve (2).
- d. Install new drain valve (2) by turning cw.

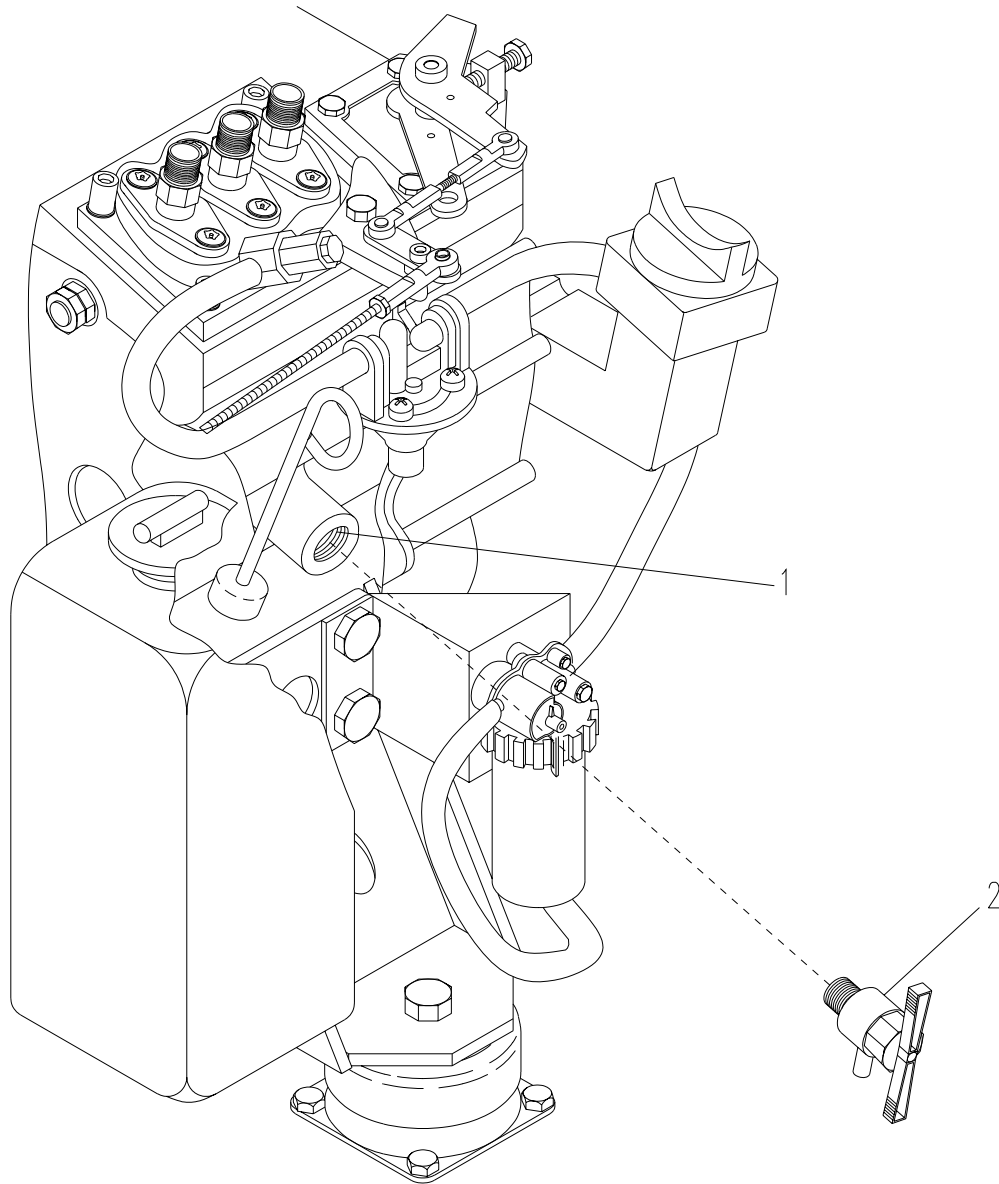

Figure 4-8. Engine Coolant Drain Valve

4.22. THERMOSTAT.

This task covers: a. Test b. Replace

INITIAL SETUP

Tools

Thermometer, Glass
(Item 21, Appendix B)
Small Pan

Equipment Condition

Engine stopped and allowed to cool completely.
MASTER ON-OFF switch on APU controller set to OFF.

Materials/Parts

Thermostat
Sealing Compound 88-20595-2
(Item 18, Appendix F)
Gasket, Thermostat Housing
(Item 10, Appendix J)

WARNING

Hot coolant is under pressure. Do not remove radiator cap when engine is hot. Allow engine to cool completely before removing radiator cap. Once cooling has occurred, loosen cap slightly to relieve any excess pressure before removing the cap completely. Failure to observe this warning could result in burns or injury to personnel.

TEST

- a. Remove thermostat (perform steps a through c of REPLACE procedure).
- b. Suspend thermostat (4, Figure 4-9) by a string with one end of string inserted between the valve and seat.
- c. Immerse the thermostat (4) in a pan of water (5).
- d. Heat the water gradually and read the temperature on the thermometer (3) when the valve opens making the thermostat fall off the string. The valve should open between 157.1°F and 162.5°F (69.5°C and 72.5°C).

NOTE

Valve should completely open to 0.2367 in. (6 mm) at 185°F (85°C).

- e. If the valve does not open properly, replace the thermostat (4).

REPLACE

- a. Loosen two clamps (1) and remove radiator water hose (2) from thermostat housing (7).
- b. Remove two bolts and lock washers (9), thermostat housing (8) and gasket (7).
- c. Remove thermostat (4) from temperature sensor block (6).
- d. Thoroughly clean temperature sensor block (6) and thermostat housing (8).

- e. Install new thermostat (4) in temperature sensor block (6).
- f. Apply sealing compound to both sides of new gasket (7) and install thermostat housing on temperature sensor block (6). Secure with gasket (7), two bolts and lock washers (9).
- g. Install water hose (2) over thermostat housing (8) and tighten two clamps (1).

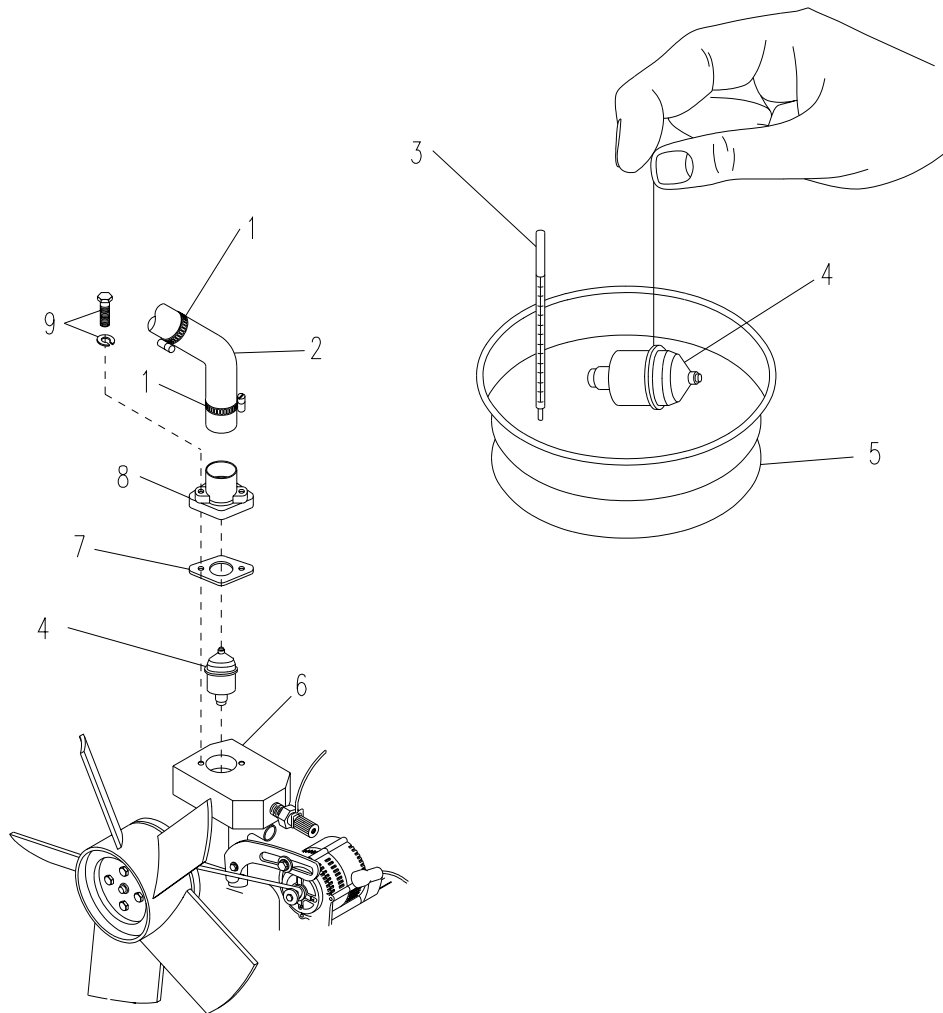

Figure 4-9. Thermostat

4.23. FAN BELT.

This task covers: a. Inspect b. Adjust c. Replace

INITIAL SETUP

Tools

General Mechanic's Tool Kit
(Item 1, Appendix B)

12.0mm Socket Wrench Socket
(Item 50, Appendix B)

14.0mm Socket Wrench Socket
(Item 51, Appendix B)

Equipment Conditions

Engine stopped and allowed to cool completely.

MASTER ON-OFF switch on APU controller set to OFF.

Fan guard, fan shroud and shroud housing removed (para 4.18.).

Materials/Parts

Fan Belt

INSPECT

Inspect fan belt (8, Figure 4-10) for wear. Fan belt (8) should be flush with top of groove in each pulley (1, 6, and 9). If fan belt (8) is not flush with top of groove in each pulley (1, 6, and 9), replace fan belt (8).

ADJUST

- a. Press the fan belt (8) between the fan pulley (1) and the alternator pulley (6) with your finger firmly (approximately 22 lbs (10 kg)). Fan belt deflection should be about 0.874 inches (2.2 cm).
- b. If deflection is not correct, loosen adjusting bolt (4).
- c. Move alternator (3) in bracket (5), tighten adjusting bolt (4), and test deflection. Repeat steps a through c until correct deflection is reached.
- d. When correct deflection is reached, tighten adjusting bolt (4).

REPLACE

NOTE

If belt is too tight to be removed, remove battery charging alternator (para 4.36).

- a. Loosen pivot bolt (7), on bottom of alternator (3).
- b. Loosen adjusting bolt (4).
- c. Slide alternator (3) in adjusting bracket (5) until fan belt (8) is loose.
- d. Remove fan belt (8) from alternator pulley (6), fan pulley (1), and crankshaft pulley (9).
- e. Remove fan belt (8) over fan (2).
- f. Install fan belt (8) over fan (2).

- g. Install fan belt (8) over crankshaft pulley (9), fan pulley (1), and alternator pulley (6).
- h. Slide alternator (3) in adjusting bracket (5) until fan belt (8) is tight.
- i. Tighten adjusting bolt (4).
- j. After installation, adjust fan belt tension.
- k. Re-check tension after 10 minutes of operation.

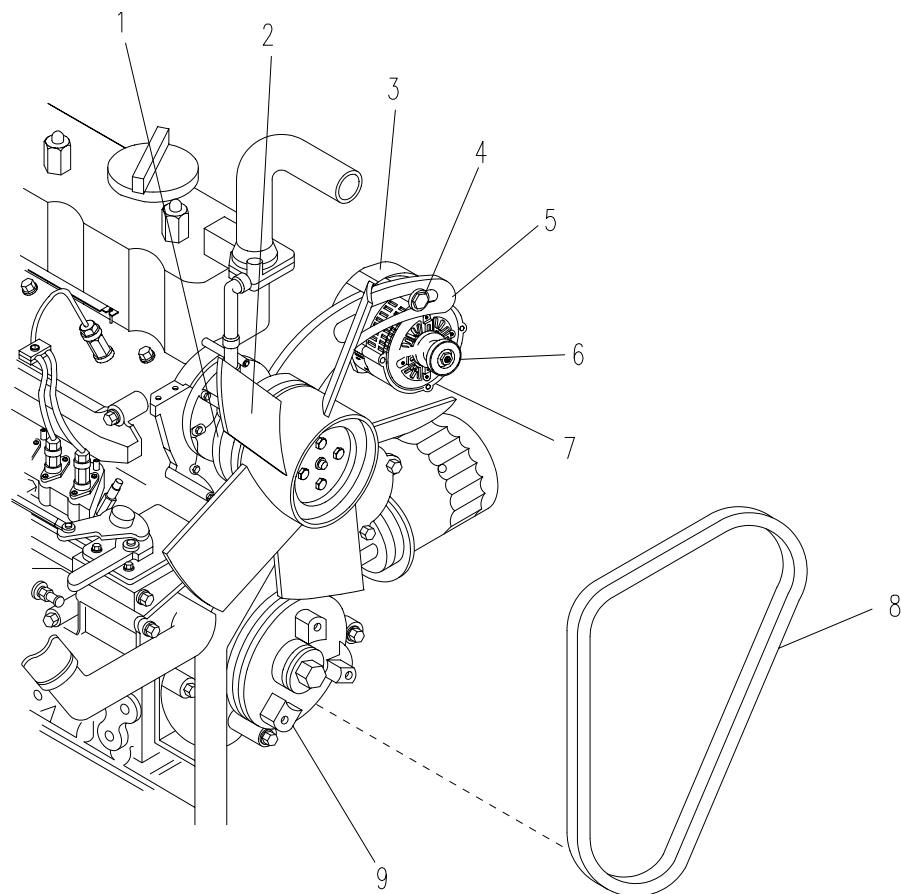

Figure 4-10. Fan Belt

4.24. RADIATOR HOSES.

This task covers: a. Inspect b. Replace

INITIAL SETUP

Tools

General Mechanic's Tool Kit

Equipment Conditions

Engine stopped and allowed to cool completely.

MASTER ON-OFF switch on APU controller set to OFF.

Materials/Parts

Radiator Hoses

INSPECT

- a. Inspect upper and lower radiator hoses (1 and 12, Figure 4-11), oil cooler inlet hose (6), oil cooler outlet hose (8), and radiator overflow tank hose (3) for loose clamps, water leakage, swelling, hardening, or cracking.
- b. Tighten loose clamps or replace square clamps.
- c. Replace deteriorated radiator hoses.

REPLACE

- a. Drain engine coolant (para 4.19.).
- b. Loosen two clamps (2) and remove upper radiator hose (1).
- c. Loosen two clamps (13) and remove lower radiator hose (14).
- d. Loosen two clamps (9) and remove oil cooler water inlet hose (8).
- e. Loosen two clamps (10) and remove oil cooler water outlet hose (12).
- f. Loosen two clamps (4) and remove ends of radiator overflow tank hose (5) from radiator overflow pipe (3) and radiator overflow tank (11).
- g. Remove one screw and lock and flat washer (7), brace (6), and radiator overflow tank hose (5).
- h. Install new oil cooler water outlet hose (12) and secure with two clamps (10).
- i. Install new oil cooler water inlet hose (8) and secure with two clamps (9).
- j. Install new lower radiator hose (14) and secure with two clamps (13).
- k. Install new upper radiator hose (1) and secure with two clamps (2).

- l. Install ends of new radiator overflow tank hose (5) to radiator overflow pipe (3), and radiator overflow tank (11).
- m. Secure radiator overflow tank hose with one brace (6) and screw and flat and lock washer (7).
- n. Replace radiator coolant (para 4.19.).

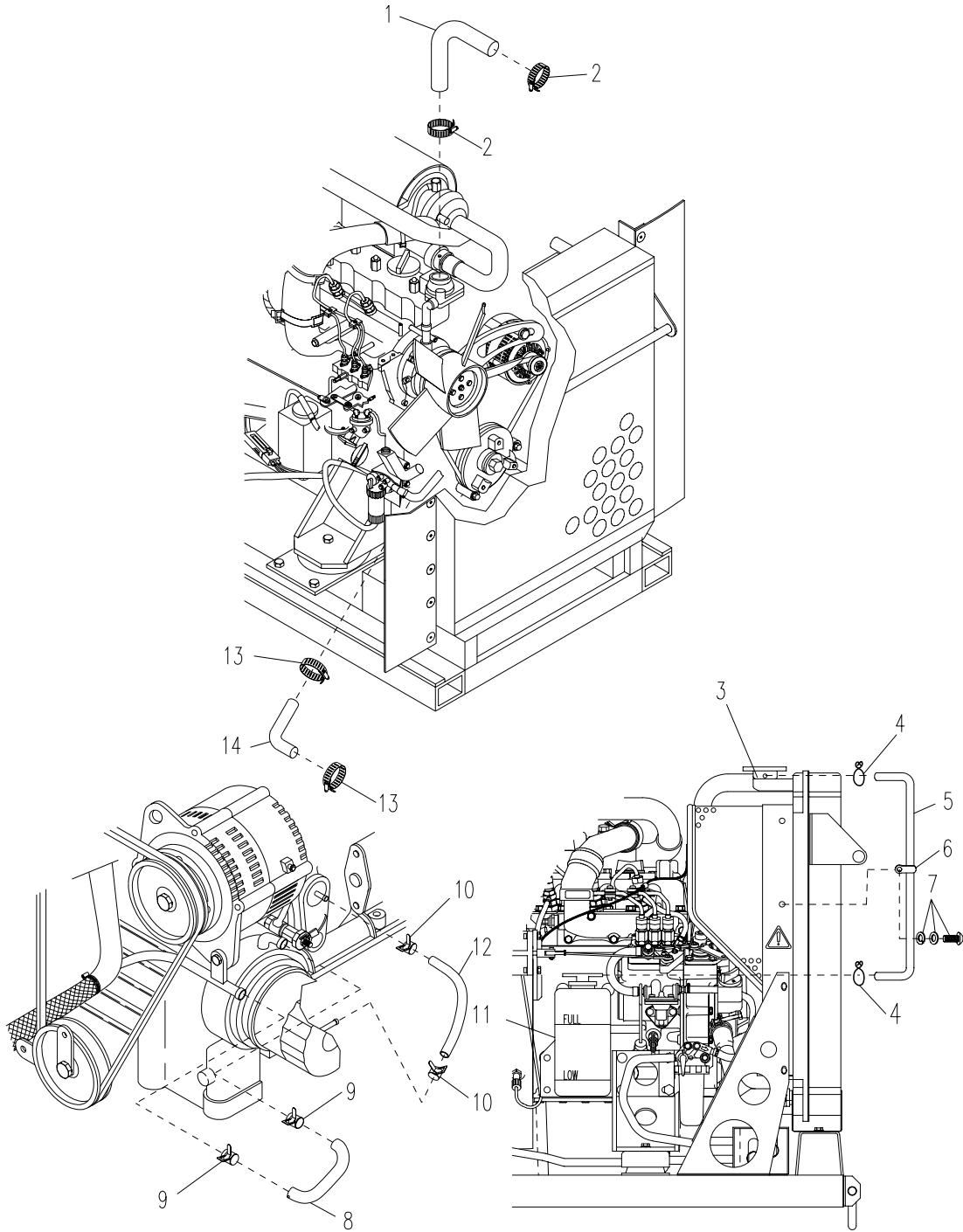

Figure 4-11. Radiator Hoses

4.25. TEMPERATURE SENDER.

This task covers: a. Test b. Replace

INITIAL SETUP

Tools

Shop Equipment, Electrical Repair,
Semi trailer Mounted
(Item 3, Appendix B)

Equipment Conditions

Engine stopped and allowed to cool completely.
MASTER ON-OFF switch on APU controller set to
OFF.

Materials/Parts

Temperature Sender

Sealing Compound 88-20595-2
(Item 18, Appendix F)

TEST

- a. Remove cap (5, Figure 4-12) and tag electrical lead (4).
- b. Remove electrical lead (4) and lock washer (3) from sender (2).
- c. Start APU (para 2.5.) and monitor resistance to ground from terminal on sender. As engine heats up, resistance should decrease to 72.3 ± 4.3 ohms. If not, replace sender (2).
- d. Shut down APU (para 2.6.).

REPLACE

WARNING

Allow engine to cool completely before removing temperature sender. Failure to observe this warning will result in severe injury to personnel.

- a. Drain coolant.
- b. Remove cap (5, Figure 4-12, Sheet 2) and tag electrical lead (4).
- c. Remove electrical lead (4) and lock washer (3).
- d. Remove temperature sender (2) from temperature sender mounting block (1) by turning counter clockwise (ccw).
- e. Apply sealing compound to threads on new temperature sender.
- f. Install new sender (2) in temperature sender mounting block (1).
- g. Install lock washer (3), electrical lead (4), and cap (5) on temperature sender terminal (2). Remove tag.

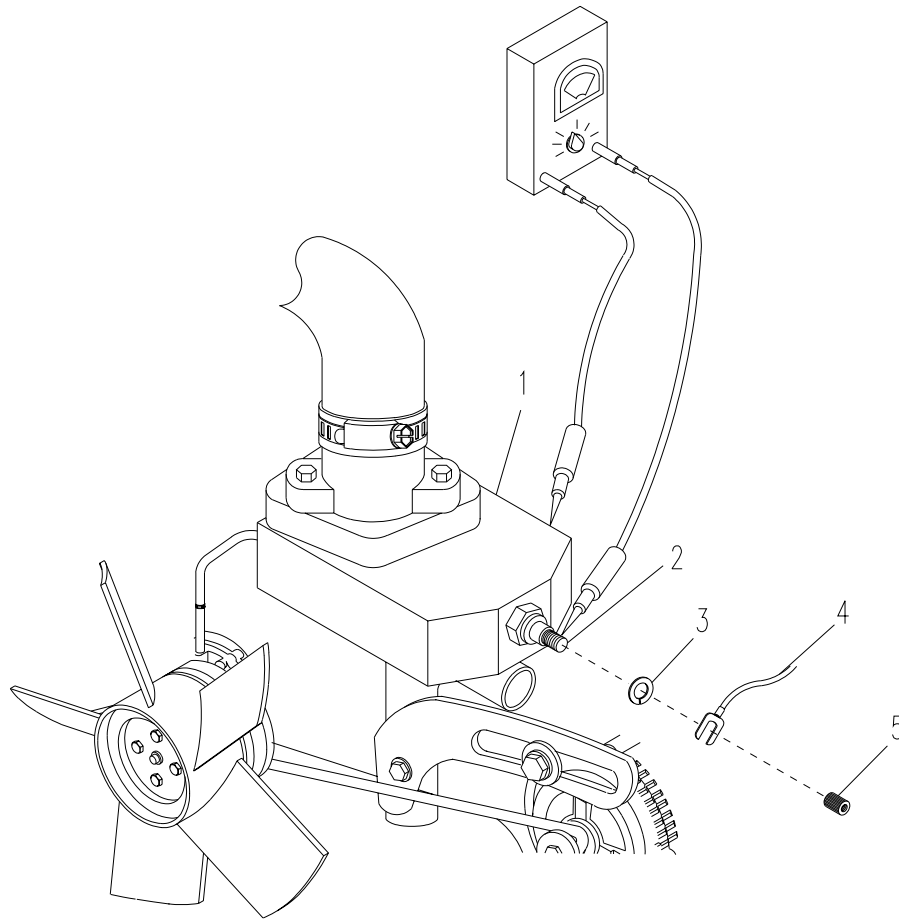

Figure 4-12. Temperature Sender

4.26. TEMPERATURE SWITCH.

This task covers: a. Test b. Replace

INITIAL SETUP

Tools

Shop Equipment, Electrical Repair,
Semitrailer Mounted
(Item 3, Appendix B)

Equipment Conditions

Engine stopped and allowed to cool completely.

MASTER ON-OFF switch on APU controller set to
OFF.

Materials/Parts

Temperature Switch

Sealing Compound 88-20595-2
(Item 18, Appendix F)

TEST

- a. Squeeze sides and remove electrical lead (2, Figure 4-13) from temperature switch (1).
- b. Remove temperature switch (1) from water flange (3).
- c. Place lead of multimeter on each end of temperature switch (1) and test for no continuity. If continuity is observed, switch is faulty. Replace switch.

REPLACE

- a. Squeeze and remove electrical lead (2) from temperature switch (1).
- b. Remove temperature switch (1) from water flange (3).
- c. Apply sealing compound to threads on new temperature switch (1).
- d. Install new temperature switch (1) into water flange (3).
- e. Install electrical lead (2) on new temperature switch.

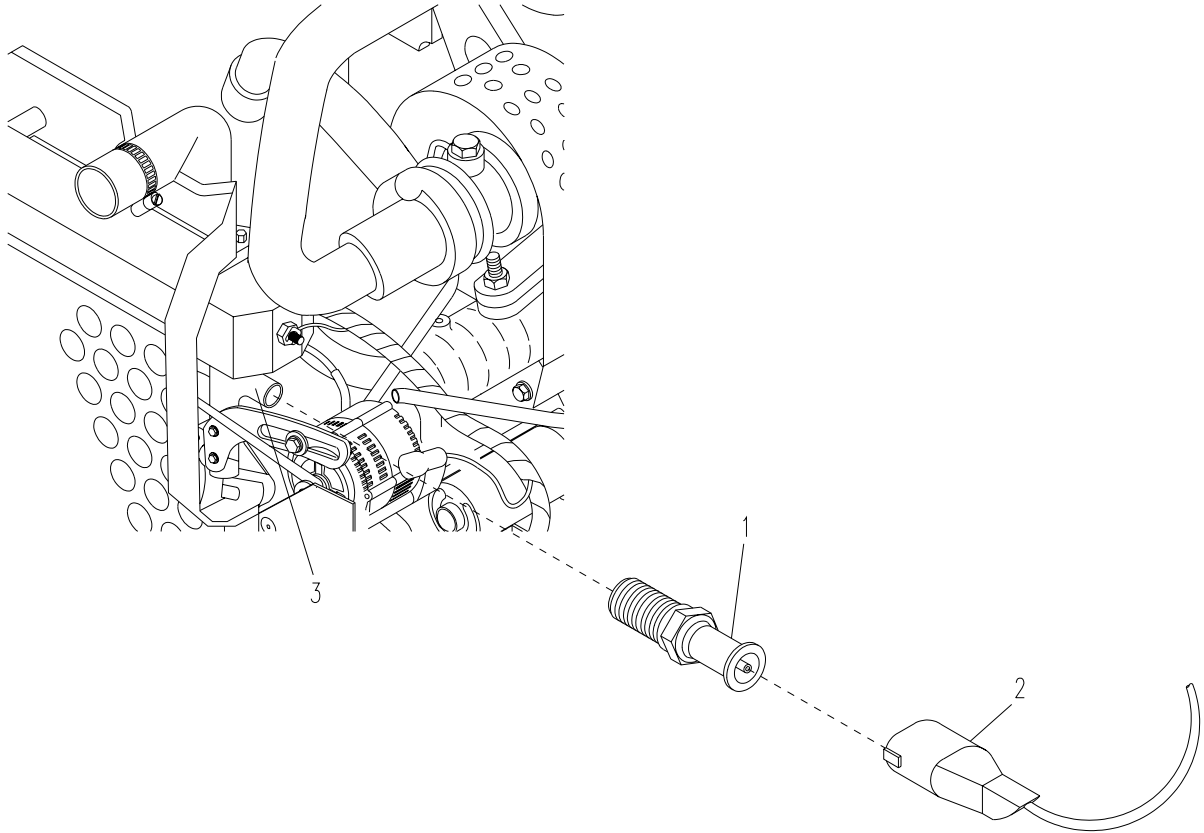

Figure 4-13. Temperature Switch

4.27. BREATHER.

This task covers: Service

INITIAL SETUP

Tools

General Mechanic's Tool Kit
(Item 1, Appendix B)

Equipment Conditions

Engine stopped and allowed to cool completely.

Master ON-OFF switch on APU control unit set to OFF.

Materials/Parts

Breather Tube

Waterflange removed (para 6.33.).

Air intake pipe removed (para 4.47.).

Sealing Compound 88-20595-2
(Item 18, Appendix F)

SERVICE

- a. Remove nut and lock washer (3, Figure 4-14) securing breather tube clamp (4) to alternator support bracket (1) and remove clamp (4).
- b. Remove breather tube (2) from clamp (4).
- c. Remove breather tube (2, Figure 4-14 (sheet 2)) from breather pipe (6).
- d. Inspect breather tube (2) and replace if showing signs of corrosion.
- e. Remove breather pipe (6) from breather (5) by turning ccw.
- f. Clean breather with soft, lint-free cloth and remove any dirt or grease blocking opening.
- g. Clean exterior of breather pipe (6) and breather tube (2) with soft, lint-free cloth.

WARNING

Compressed air shall not be used for cleaning purposes except where reduced to less than 29 pounds per square inch gauge (psig) (199.94 kPa) and then only with effective chip guarding and personnel protective equipment. Compressed air is dangerous and can cause serious bodily harm if protective means or methods are not observed to prevent chip or particle (of whatever size) from being blown into the eyes or unprotected skin of the operator or other personnel.

- h. Blow out breather pipe (6) and breather tube (2) with compressed air.
- i. Apply sealant to threads of breather pipe (6) and install breather pipe on to breather (5) by turning ccw.
- j. Install breather tube (2) on to breather pipe (6).

- k. Install breather tube (2) from clamp (4).
- l. Secure breather tube clamp to alternator support bracket with one lock washer and nut.

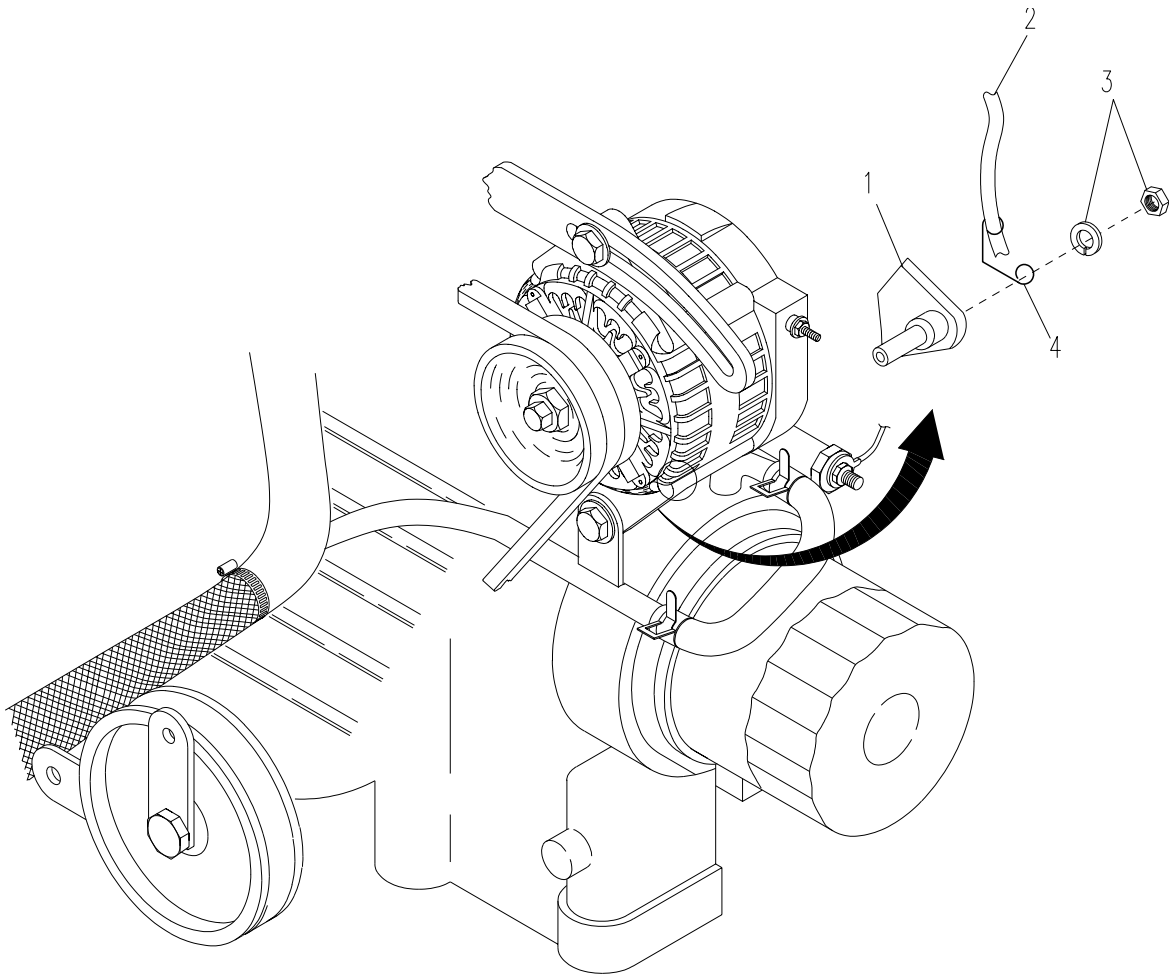

Figure 4-14. Breather (Sheet 1 of 2)

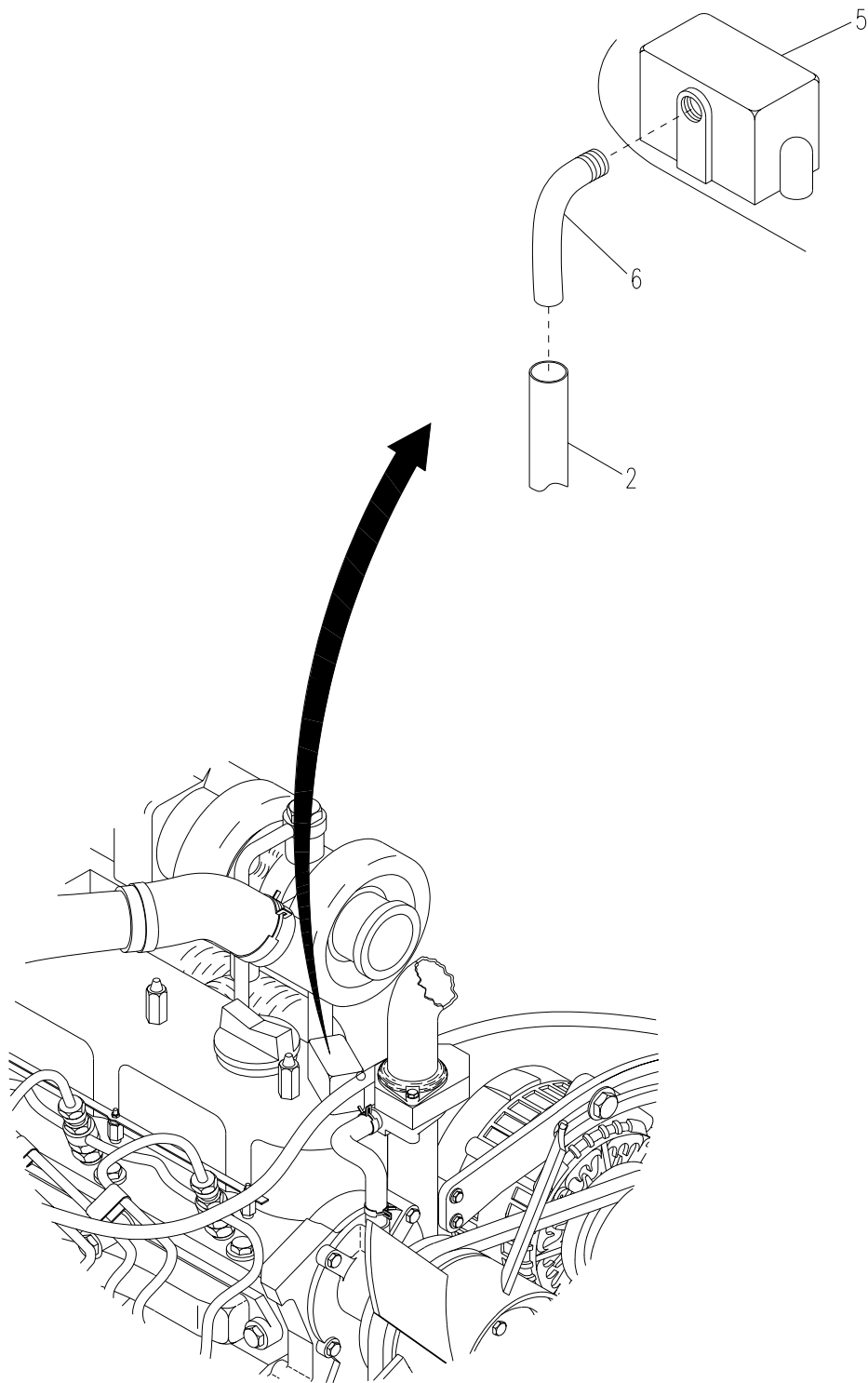

Figure 4-14. Breather (Sheet 2)

4.28. RADIATOR OVERFLOW TANK.

This task covers: Replace

INITIAL SETUP

Tools

None

Equipment Conditions

Engine stopped and allowed to cool completely.

MASTER ON-OFF switch on APU control unit set to OFF.

Materials/Parts

Radiator Overflow Tank

REPLACE

- a. Loosen clamp (4, Figure 4-15) and remove radiator overflow hose (5) from radiator overflow tank cap (2).
- b. Lift radiator overflow tank (3) off of radiator overflow tank bracket (6).
- c. Remove overflow hose (1) from radiator overflow tank cap (2).
- d. Install overflow hose (1) on new overflow tank cap (2).
- e. Install new radiator overflow tank (3) on radiator overflow tank bracket (6).
- f. Install radiator overflow hose (5) on radiator overflow tank cap (2) and secure with clamp (4).

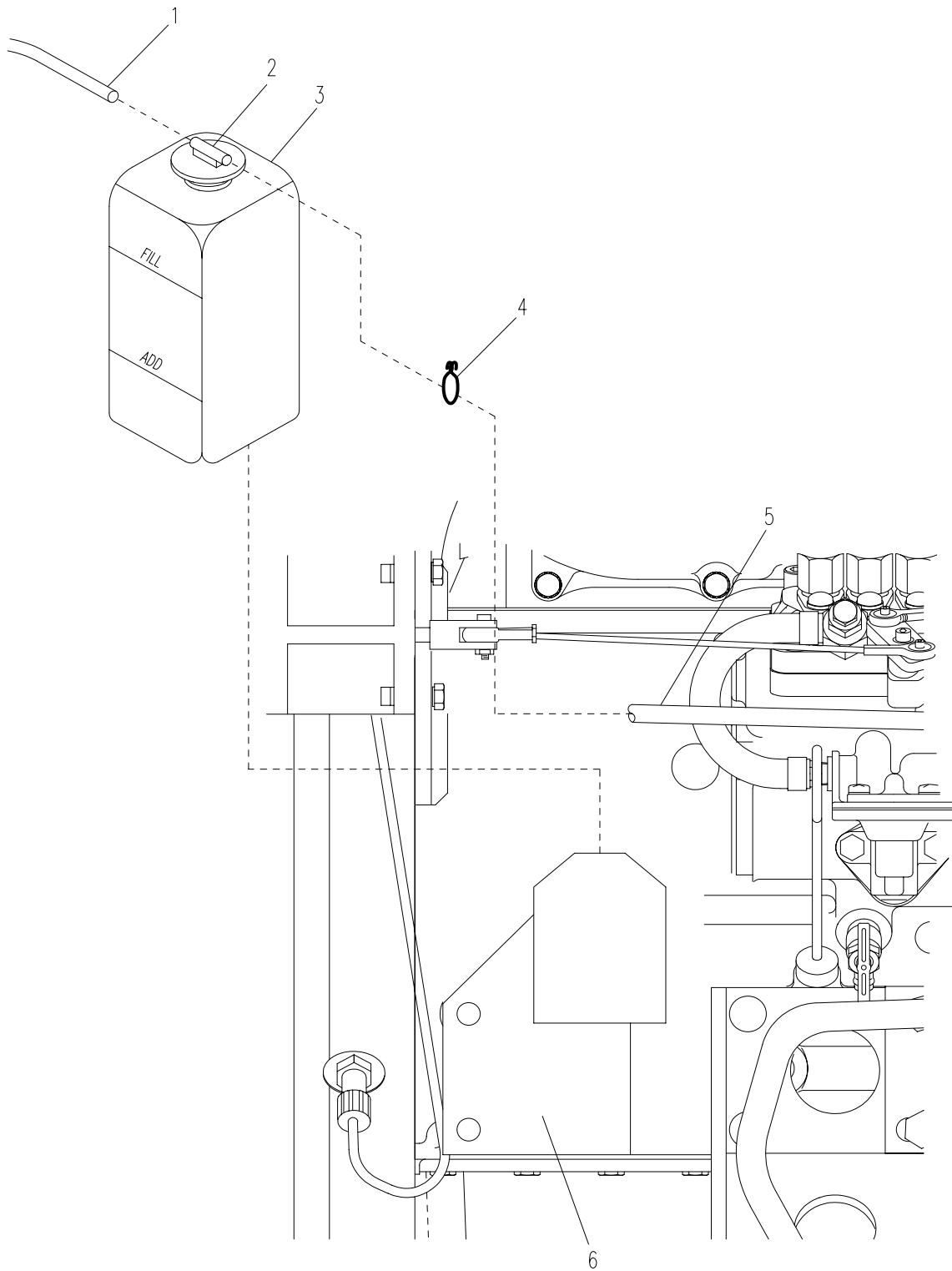

Figure 4-15. Radiator Overflow Tank

4.29. FUEL SYSTEM.

This task covers: Service

INITIAL SETUP

Tools

General Mechanic's Tool Kit
(Item 1, Appendix B)

Gloves, Chemical and 0.1 Protective

Materials/Parts

None

Equipment Conditions

Engine stopped and allowed to cool completely.

MASTER ON-OFF switch on APU control unit set to OFF.

Personnel Required

Two

SERVICE

WARNING

Ensure that NO IGNITION SOURCE is within 50 feet of the 10 kW APU. The fuel in this APU is highly flammable. Do not smoke. Do not splash fuel on hot components. Failure to heed this warning could result in serious injury to personnel or DEATH.

WARNING

Avoid fuel contact with skin. Wear protective gloves, goggles, apron and mask, while disconnecting fuel lines. Failure to this warning could result in serious injury to personnel or DEATH.

NOTE

Service of the fuel system is accomplished by bleeding air out from the fuel system. Bleeding the fuel system must be performed whenever a major component of the fuel system has been replaced or during service upon receipt to prime the system. Normally, the APU will not need to be primed each time it is started.

- a. With the APU installed in the shelter, vehicle fuel line attached to fuel transfer pump, and fuel return line attached from day tank back to vehicle fuel tank, position MASTER ON-OFF switch to ON.
- b. On APU control unit, position BATTLE SHORT switch to ON. This will allow fuel transfer pump to override safety protection devices.
- c. Allow pump to run until day tank has been filled (observe that LOW FUEL indicator on control unit goes out).
- d. Open fuel bleed port (1, Figure 4-16) on the injection pump.

NOTE

Use suitable container to catch purged fuel.

- e. Disconnect fuel return line at vehicle entrance fitting and cap fuel line to generator set with a fuel tight plug. (Refer to System TM for location of vehicle fuel return lines.)
- f. Disconnect J7(6) from P7(7) (Figure 4-17) and install jumper switch to P7(7) engine wiring harness. (Ensure switch is off prior to connecting to wiring harness.)
- g. Open fuel valve (1, Figure 4-14) on fuel filter.
- h. Open two bleed Screws (2, Figure 4-14) on fuel filter.
- i. Turn MASTER SWITCH to ON position.
- j. Turn Jumper Switch to ON position. When a solid stream of fuel flows from the fuel filter bleed screws close the bleed screws and turn OFF the Jumper Switch.
- k. Open Fuel injection Pump Bleed Screw (3, Figure 4-14).
- l. Turn Jumper Switch to ON position. When a solid stream of fuel flows from the Fuel Injection Pump Bleed Screw, close the Fuel Injection Pump Bleed Screw and turn the Jumper Switch to the OFF position.
- m. Turn MASTER SWITCH to OFF position.
- n. Disconnect Jumper Switch from P7 and reconnect P7 to J7.
- o. Reconnect fuel line to vehicle.

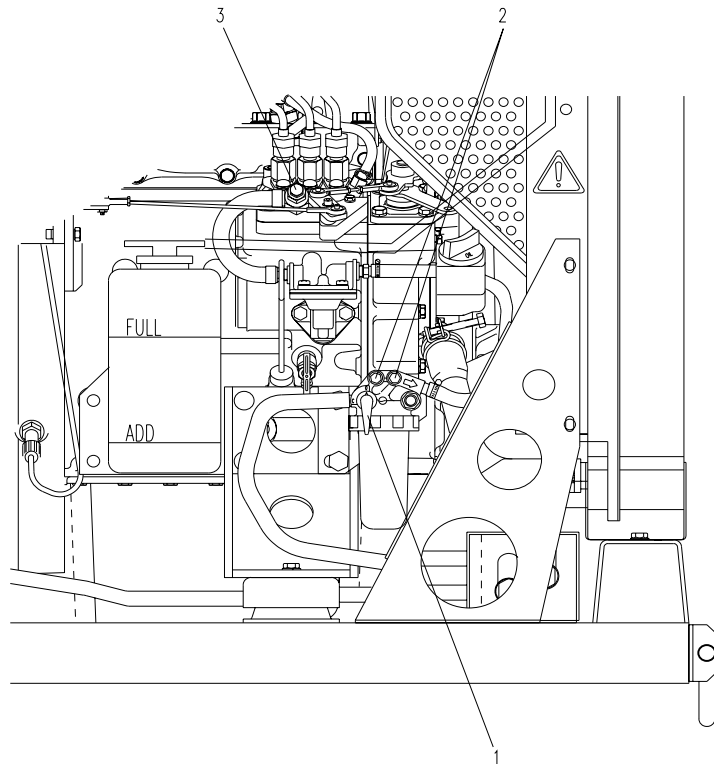

Figure 4-16. Fuel System

4.30. FUEL FILTER ASSEMBLY.

This task covers: a. Service b. Replace

INITIAL SETUP

Tools

General Mechanic's Tool Kit
(Item 1, Appendix B)

Gloves, Chemical and Oil Protective
(Item 34, Appendix B)

Materials/Parts

Fuel Filter

An approved solvent
(Item 9, Appendix F)

Equipment Conditions

MASTER ON-OFF switch on APU control unit set to OFF.

Engine stopped and allowed to cool completely.

SERVICE

WARNING

Ensure that NO IGNITION SOURCE is within 50 feet of the 10 kW APU. The fuel in this APU is highly flammable. Do not smoke. Do not splash fuel on hot components. Failure to heed this warning could result in serious injury to personnel or DEATH.

WARNING

Avoid fuel contact with skin. Wear protective gloves, goggles, apron and mask, while disconnecting fuel lines. Do not splash fuel on hot components. Failure to heed this warning could result in serious injury to personnel or DEATH.

- a. Clean fuel filter element.
 - (1) Remove fuel filter element (perform steps b (1) through b (3)).
 - (2) Rinse the inside of the filter cup with an approved solvent.
 - (3) Rinse the filter element with an approved solvent.
 - (4) Install fuel filter element (perform steps b (5) through b (9)).

NOTE

Have suitable container available to catch fuel spill.

- b. Replace fuel filter element.
 - (1) Remove radiator support bracket (perform Para 4.18., REMOVE, step d).
 - (2) Close fuel filter valve (1, Figure 4-17) (up-down position).

- (3) Remove screw ring (5) by turning ccw and remove filter cup (4) and O-ring (2).
- (4) Remove filter element (3) from filter cup (4) and discard filter element.
- (5) Place new filter element (3) inside filter cup (4).
- (6) Secure cup (4) to valve body (6) by tightening screw ring (5).
- (7) Open fuel filter valve (1) (side-to-side position).
- (8) Install radiator support bracket (perform para 4.18. REPLACE step f).
- (9) Bleed fuel system (para 4.29.).

REPLACE

WARNING

Ensure that NO IGNITION SOURCE is within 50 feet of the 10 kW APU. The fuel in this APU is highly flammable. Do not smoke. Do not splash fuel on hot components. Failure to heed this warning could result in serious injury to personnel or DEATH.

WARNING

Avoid fuel contact with skin. Wear protective gloves, goggles, apron and mask, while disconnecting fuel lines. Failure to heed this warning could result in serious injury to personnel or DEATH.

- a. Loosen two clamps (7) and remove fuel lines (8).
- b. Remove bolt (11), flat washer (10), nut (9) fuel filter assembly (12).
- c. Install new fuel filter assembly (12) using bolt (11), flat washer (10), and nut (9).
- d. Install fuel lines (8) and secure with two clamps (7).

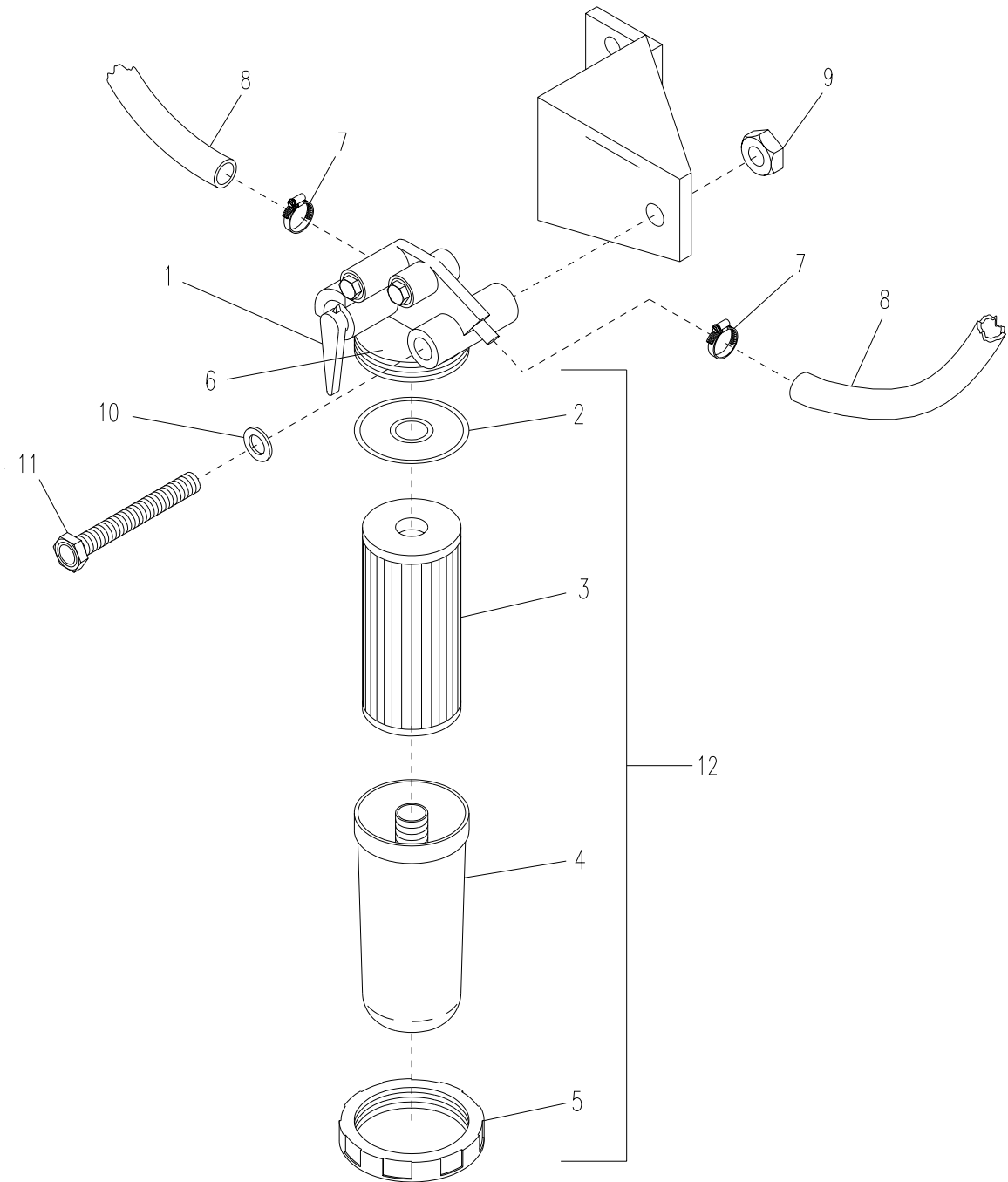

Figure 4-17. Fuel Filter Assembly

4.31. FUEL PUMP ASSEMBLY.

This task covers: a. Test b. Replace

INITIAL SETUP

Tools

General Mechanic's Tool Kit
(Item 1, Appendix B)

Hand Siphon
(Item 22, Appendix B)

Gloves, Chemical and Oil Protective
(Item 34, Appendix B)

Materials/Parts

Fuel Pump Assembly

Equipment Conditions

MASTER ON-OFF switch on APU control unit set to OFF.

Engine stopped and allowed to cool completely.

TEST

WARNING

Ensure that NO IGNITION SOURCE is within 50 feet of the 10 kW APU. The fuel in this APU is highly flammable. Do not smoke. Do not splash fuel on hot components. Failure to heed this warning could result in serious injury to personnel or DEATH.

WARNING

Avoid fuel contact with skin. Wear protective gloves, goggles, apron and mask, while disconnecting fuel lines. Failure to heed this warning could result in serious injury to personnel or DEATH

NOTE

When disconnecting fuel lines, a suitable container should be used to catch fuel leaking from disconnected fuel lines.

- a. Cut wire ties (if applicable).
- b. Loosen clamp (6, Figure 4-18) and remove fuel line (7) from fittings (5) on fuel pump assembly (4).
- c. Attach one end of a suitable hose to outlet side of fuel pump assembly and place other end in a container approved to hold diesel fuel.
- d. On control panel, position MASTER ON-OFF switch to ON and BATTLE SHORT switch to ON. Fuel pump should immediately pump fuel into container. If fuel does not pump, replace fuel pump.

WARNING

REPLACE

Ensure that NO IGNITION SOURCE is within 50 feet of the 10 kW APU. The fuel in this APU is highly flammable. Do not smoke. Do not splash fuel on hot components. Failure to heed this warning could result in serious injury to personnel or DEATH.

WARNING

Avoid fuel contact with skin. Wear protective gloves while disconnecting fuel lines. Failure to heed this warning could result in serious injury to personnel or DEATH.

NOTE

When disconnecting fuel lines, use suitable container to catch fuel leaking from disconnected fuel lines.

- a. Cut wire ties (if applicable).
- b. Remove fuel supply line hose (15).
- c. Loosen clamp (6) and remove fuel line (7) from fitting (5) on fuel pump assembly (4). d. Disconnect P8 connector from J8.
- e. Remove screw, lock washer, and flat washer (3) securing fuel pump bracket (1) to generator mount (8).
- f. Loosen screw (14) and nut and lock washer (2), and slide fuel pump (4) out from bracket (1). g. Slip bracket (1) over fuel pump (4) and tighten screw (14), nut and lock washer (2).
- h. Align bracket hole with hole on generator mount (8) and secure with flat and lock washer and screw (3).
- i. Reconnect P-8 to J-8.
- j. Install fuel line and tighten clamp (6).
- k. Install fuel supply line hose (15) on fuel pump (4).
- l. Bleed fuel system (para 4.29.).
- m. Reinstall wire ties (if applicable)(16),

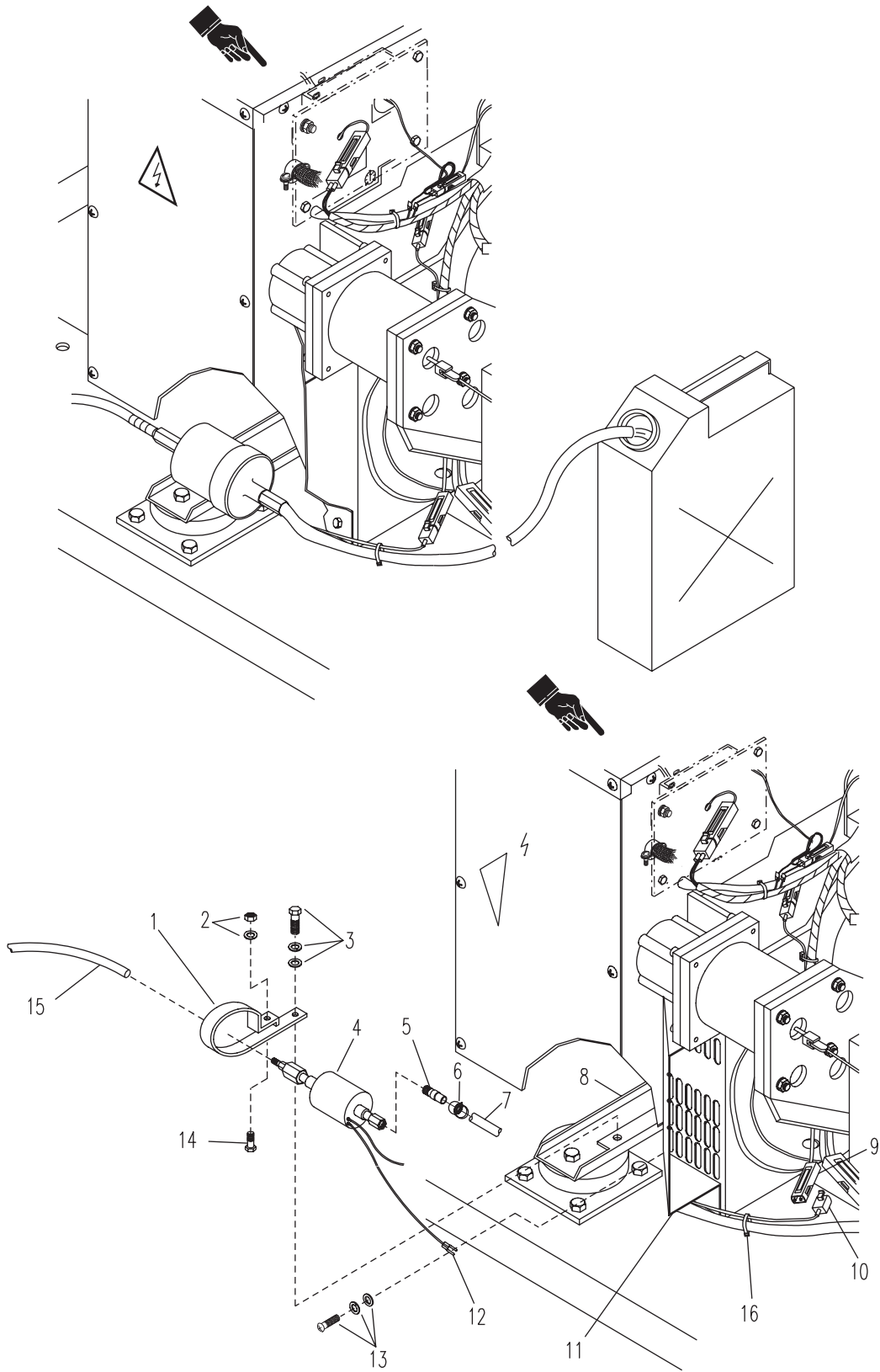

Figure 4-18. Fuel Pump Assembly

4.32. FUEL DAY TANK ASSEMBLY (JTACS and WIN-T).

This task covers: a. Service b. Test c. Repair d. Replace

INITIAL SETUP

Tools

Shop Equipment, Electrical Repair,
Semi trailer Mounted
(Item 3, Appendix B)

Hand Siphon
(Item 22, Appendix B)

Gloves, Chemical Oil Protective
(Item 34, Appendix B)

Materials/Parts
Low-level Cut-off Switch

Sealing Compound 88-20595-2
(Item 18, Appendix F)

Approved Solvent

Equipment Conditions

Engine stopped and allowed to cool completely.

MASTER ON-OFF switch on APU control unit set to OFF.

WARNING

Ensure that NO IGNITION SOURCE is within 50 feet of the 10 kW APU. The fuel in this APU is highly flammable. Do not smoke. Do not splash fuel on hot components. Failure to heed this warning could result in serious injuries to personnel or DEATH.

WARNING

Avoid fuel contact with skin. Wear protective gloves, goggles, apron and mask, while disconnecting fuel lines. Failure to heed this warning could result in serious injuries to personnel or DEATH.

NOTE

When disconnecting fuel lines, use a suitable container to catch fuel from disconnected fuel lines.

SERVICE

CAUTION

Take care not to cut wires or other APU components when removing tiedown straps.

NOTE

Cut and remove tiedown straps as needed to remove wiring harness.

NOTE

When removing, make note of tiedown strap locations. Wiring harness will need to be secured at approximately the same places.

- a. Service by performing STEPS a through t of REPLACE.

TEST

- a. Drain fuel day tank assembly by (performing STEPS a through e of REPLACE).
- b. Refer to Figure FO-1 (WIN-T) or FO-7 (JTACS) and tag and disconnect connector J7 (6, Figure 4-19) from engine wiring harness connector P7 (7).
- c. Connect multimeter leads on pins C and D at connector J7 (6). There should be continuity.
- d. Siphon fuel from overflow container into fuel day tank (4) through fuel intake hole (8). When sufficient fuel has been added, the closed lower switch will open and no continuity will be observed. Stop siphoning.

NOTE

Both lower and upper switches are connected to connector J7. If one switch is faulty, both switches and connector J7 must be replaced.

- e. If continuity is observed, replace switches (5).
- f. Place sealing compound on fitting threads and install fitting (10).
- g. Install line (12) to fitting (10) and secure with clamp (11).
- h. Add sealing compound to threads of fitting (10), and install in fuel day tank.
- i. Connect hose from overflow container to fitting (10).
- j. Connect leads of multimeter to pins A and B at connector J7 (6). There should be continuity.
- k. Add fuel to overflow container, if necessary, and siphon additional fuel back into fuel day tank (4).
- l. When sufficient fuel has been added, the closed upper liquid level switch will open and no continuity will be observed.
- m. If continuity is observed, replace switches (5).
- n. If both switches are good, remove siphon.
- o. Install line (12) between transfer pump and fuel day tank (4) on fitting (10) and secure with clamp (11).

- p. Reconnect connector J7 (6) to connector P7 (7).
- q. Bleed the fuel system (para 4.29.).

REPAIR

- a. Cut wire ties.
- b. Perform STEPS a through e of REPLACE.
- c. Refer to Figure FO-1 (WIN-T) or FO-7 (JTACS) and disconnect connector J7 (6, Figure 4-19) from connector P7 (7).

NOTE

When removing low-level cut-off switches, use a suitable container to catch fuel leaking from disconnected fuel lines.

- d. Remove both low-level cut-off switches (5).
- e. Apply sealing compound to threads of both new low-level cut-off switches (5) and install switches.
- f. Connect line from transfer pump (12) to fitting (10), and secure with clamp (11).
- g. Reconnect connector J7 (6) to connector P7 (7).
- h. Replace wire ties.
- i. Reinstall radiator support bracket (3) securing with two bolts and lock and flat washers (1) and two screws and flat and lock washers (2).
- j. Replace cable ties as required.
- k. Bleed the fuel system (para 4.29.).

REPLACE

CAUTION

Take care not to cut wires or other APU components when removing tiedown straps.

NOTE

Cut and remove tiedown straps as needed to remove wiring harness.

NOTE

When removing tiedown straps, make note locations. Wiring harness will need to be secured at approximately the same places.

- a. Remove two bolts and lock and flat washers (1, Figure 4-19), and two screws and flat and lock washers (2), and remove radiator support bracket (3).
- b. Loosen clamp (11) and remove line (12) between fuel pump assembly and fuel day tank assembly (4) from fitting (10) at fuel intake hole (8).
- c. Remove fitting (10) from fuel intake hole (8).
- d. Route hand siphon through fuel intake hole (8) into fuel day tank (4) and route other end of line into an overflow container.
- e. Siphon fuel out of fuel day tank (4).
- f. Disconnect connector J7 (6) from connector P7 (7).
- g. Remove fuel lines from fuel day tank assembly (4). Proceed as follows:
 - (1) Loosen clamp (11) and remove transfer pump line (12) from fitting (10).
 - (2) Loosen clamp (14) and remove fuel filter line (15) from fitting (13).
 - (3) Loosen clamp (21) and remove overflow line (20) from fitting (22).
 - (4) Loosen clamp (17) and remove vehicle return line (16) from fitting (18).
- h. Remove four bolts and star and flat washers (9).
- i. Lift fuel day tank (4) so that sump in bottom of fuel day tank clears frame assembly and remove fuel day tank (4).
- j. Remove fitting (18) from 90° fitting (19) (JTACS), or external adapter (19a) (WIN-T).
- k. Remove three fittings (10, 13, and 22) and 90° fitting (19) (JTACS), or external adapter (19a) (WIN-T) from fuel day tank (4).
- l. Clean old sealing compound from all fittings (10, 13, 18, 22) and 90° fitting (19) (JTACS), or external adapter (19a) (WIN-T).
- m. Immerse fuel day tank (4) in approved solvent for two (2) minutes and drain.
- n. Rinse solvent until all sediment has been removed.
- o. Let sit until dry (one (1) hour).
- p. Apply sealing compound to threads of fittings (10, 13, and 22) and 90° fitting (19) (JTACS), or external adapter (19a) (WIN-T) and install into new fuel day tank.
- q. Apply sealing compound to threads of fitting (18) and install into 90° fitting (19) (JTACS), or external adapter (19a) (WIN-T).

- r. Slide fuel day tank (4) between engine and frame and align mounting holes with holes in frame assembly.
- s. Secure fuel day tank (4) to frame with four bolts and star and flat washers (9).
- t. Install fuel lines on fuel day tank (4). Proceed as follows:
 - (1) Install vehicle return line (16) to fitting (18) and secure with clamp (17).
 - (2) Install overflow line (20) to fitting (22) and secure with clamp (21).
 - (3) Install fuel filter line (15) to fitting (13) and secure with clamp (14).
 - (4) Install transfer pump line (12) to fitting (10) and secure with clamp (11).
- u. Reconnect connector J7 (6) to connector P7 (7).
- v. Install radiator support bracket and secure with two bolts and lock and flat washers (1), and two screws and flat and lock washers (2).
- w. Bleed fuel system (para 4.29.).

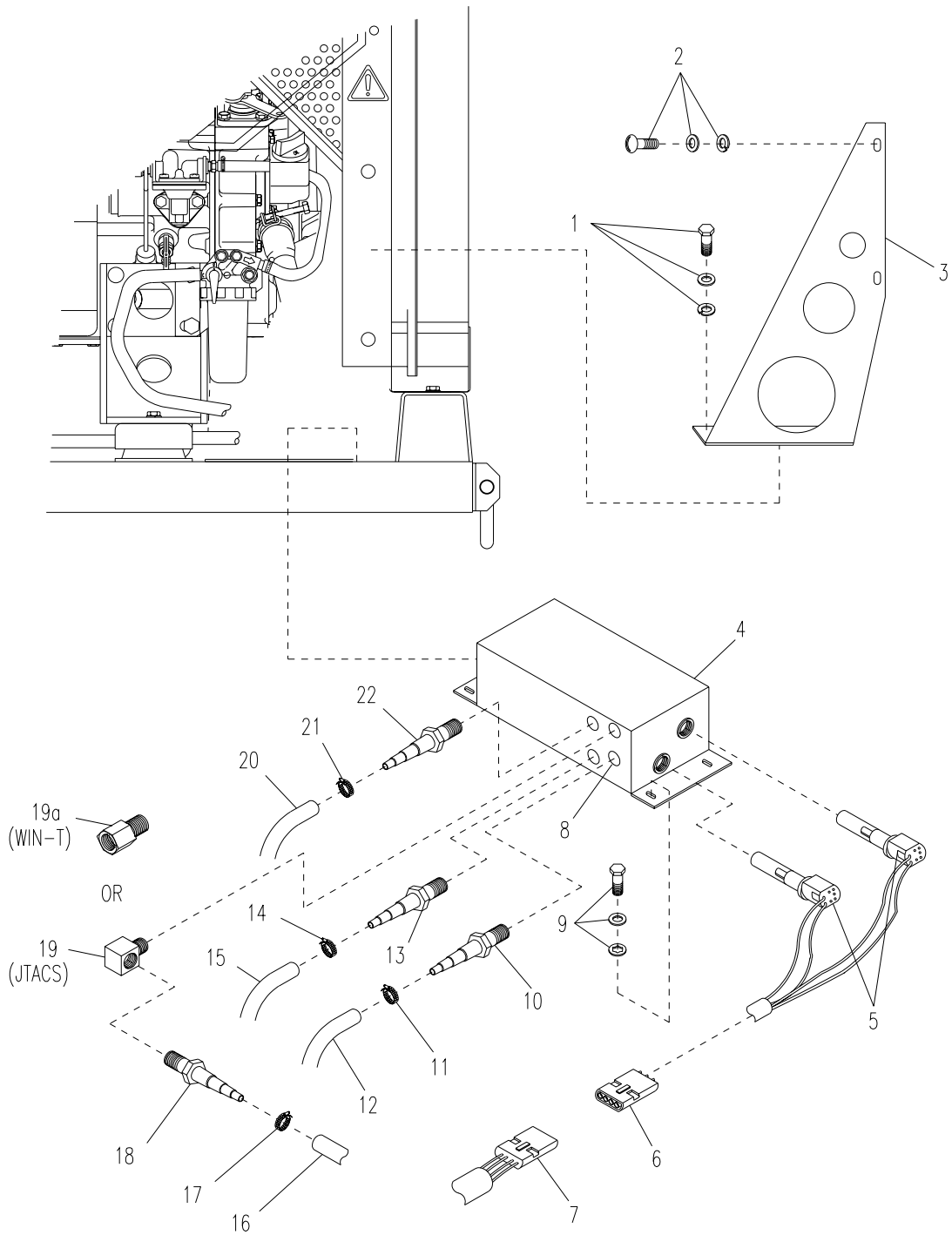

Figure 4-19. Fuel Day Tank Assembly (JTACS and WIN-T)

4.33. FUEL DAY TANK ASSEMBLY (SICPS).

This task covers: a. Service b. Test c. Repair d. Replace

INITIAL SETUP

Shop Equipment, Electrical Repair,
Semi trailer Mounted
(Item 3, Appendix B)

WARNING

Hand Siphon
(Item 22, Appendix B)

Ensure that NO IGNITION SOURCE is within 50 feet of the 10 kW APU. The fuel in this APU is highly flammable. Do not smoke. Do not splash fuel on hot components. Failure to heed this warning could result in serious injuries or DEATH.

Gloves, Chemical and Oil Protective
(Item 34, Appendix B)

WARNING

Materials/Parts

Low Level Cut-off Switch

Avoid fuel contact with skin. Wear protective gloves, goggles, apron and mask, while disconnecting fuel lines.

Sealing Compound 88-20595-2
(Item 18, Appendix F)

Approved Solvent

Equipment Conditions

NOTE

Engine stopped and allowed to cool completely.

When disconnecting fuel lines, use a suitable container to catch fuel from disconnected fuel lines.

MASTER ON-OFF switch on APU control unit set to OFF.

SERVICE

- a. Remove two bolts and flat and lock washers (1, Figure 4-20) and two screws and flat and lock washers (2), and remove radiator support bracket (3).
- b. Loosen clamp (18) and remove line (19) between fuel pump assembly and fuel day tank assembly from fitting (16) at fuel intake hole (6).

CAUTION

Take care not to cut wires or other APU components when removing tiedown straps.

NOTE

Cut and remove tiedown straps as needed to remove wiring harness.

NOTE

When removing, make note of tiedown strap locations. Wiring harness will need to be secured at approximately the same places.

- c. Remove fitting (16) from fuel intake hole (6).
- d. Route hand siphon through fuel intake hole (6) into fuel day tank (4) and route other end of line into an overflow container.
- e. Siphon fuel out of fuel day tank (4).
- f. Disconnect connector J7 (14) from connector P7 (14).
- g. Remove fuel lines from fuel day tank (4) assembly. Proceed as follows:
 - (1) Loosen clamp (22) and remove return line (23) to vehicle.
 - (2) Loosen clamp (11) and remove overflow line (10) from fuel injectors.
 - (3) Loosen clamp (8) and remove line (9) to fuel filter.
- h. Remove four bolts and washers (5).
- i. Lift fuel day tank (4) so that sump in bottom of fuel day tank clears frame assembly and remove fuel day tank (4).
- j. Remove three fittings (7, 12, and 21) from fuel day tank (4).
- k. Remove fuel level switches (13) from fuel day tank (4).
- l. Clean old sealing compound from all fittings (7) (2, 17 and 21).
- m. Immerse fuel day tank (4) in approved solvent for two minutes and drain.
- n. Rinse solvent until all sediment has been removed.
- o. Let sit until dry (one hour).
- p. Apply sealing compound to threads of fittings (7, 12, 17, and 21) and install in fuel day tank.
- q. Apply sealing compound to threads of fuel level switches (13) and install.
- r. Slide fuel day tank (4) between engine and frame and align mounting holes with in the frame assembly.
- s. Secure fuel day tank to frame with four bolts and flat washers (5).
- t. Install fuel lines on fuel day tank. Proceed as follows:
 - (1) Connect line to fuel filter (9) to fitting (7), and secure with clamp (8).
 - (2) Connect line from transfer pump (19) to fitting (17), and secure with clamp (18).
 - (3) Connect overflow line (10) from fuel line injectors to fitting (12) and secure to clamp (11).
 - (4) Connect return line to vehicle (23) and secure to fitting (21), with clamp (22).
- u. Reconnect connector J7 (14) to connector P7 (15).

- v. Install radiator support brackets (3) replace cable ties, and secure with two bolts and lock and flat washers (1), and two screws and flat and lock washers (2).
- w. Bleed fuel system (para 4.29).

TEST

- a. Drain fuel day tank assembly (perform steps a through e of SERVICE).
- b. Refer to Figure FO-1 and tag and disconnect connector J7 (14) from engine wiring harness connector P7 (15).
- c. Connect multimeter leads on pins C and D at connector J7 (14). There should be continuity.
- d. Clean fitting (17), apply sealing compound to threads of fitting, and install in hole (6) of fuel day tank (4).
- e. Connect hand siphon hose to fitting (17). Siphon fuel from overflow container into fuel day tank (4). When sufficient fuel has been added, the closed lower switch will open and no continuity will be observed. Stop siphoning.
- f. Siphon fuel from overflow container into fuel day tank (4) through fitting (16). When sufficient fuel has been added, the closed lower switch will open and no continuity will be observed. Stop siphoning.
- g. If continuity is observed, replace switches (13).

NOTE

Both lower and upper switches are connected to connector J7. If one switch is faulty, both switches and connector J7 must be replaced.

- h. Connect leads of multimeter to pins A and B at connector J7 (14). There should be continuity.
- i. Add fuel to overflow container, if necessary, and siphon additional fuel back into fuel day tank (4).
- j. When sufficient fuel has been added, the closed upper liquid level switch will open and no continuity will be observed.
- k. If continuity is observed, replace switches (13).
- l. If both switches are good, remove siphon.
- m. Add sealing compound to threads of fitting (16) and install in fuel day tank (4).

ARMY TM 9-6115-670-14&P

- n. Install fuel line (19) between transfer pump and fuel day tank on fitting (17) and secure with clamp (18).
- o. Reconnect connector J7 (14) to connector P7 (15).
- p. Bleed the fuel system (para 4.27.).

REPAIR

- a. Perform STEPS a. through i. of SERVICE.
- b. Refer to Figure FO-1 and disconnect connector J7 (14) from connector P7 (15).

NOTE

When removing liquid level switches, use a suitable container to catch fuel leaking from disconnected fuel lines.

- c. Remove both liquid level switches (13) from fuel day tank (4).
- d. Apply sealing compound to threads of new liquid level switches (13) and install in fuel day tank (4).
- e. Reconnect connector J7 (14) to connector P7 (15).
- f. Perform STEPS r. through w. of SERVICE.

REPLACE

- a. Remove two bolts and flat and lock washers (1, Figure 4-20), and two screws and flat and lock washers (2), and remove radiator support bracket (3).
- b. Disconnect connector J7 (14) from connector P7 (15).
- c. Remove fuel lines from fuel day tank (4). Proceed as follows:
 - (1) Loosen clamp (18) and remove transfer pump line (19) from fitting (17).
 - (2) Loosen clamp (8) and remove fuel filter line (9) from fitting (12).
 - (3) Loosen clamp (11) and remove overflow line (10) from fitting (12).
 - (4) Loosen clamp (22) and remove vehicle return line (23) from fitting (21).
- d. Remove four bolts and washers (5).

- e. Lift fuel day tank (4) so that sump in bottom of fuel day tank clears frame assembly and remove fuel day tank (4).
- f. Remove two fittings (7 and 12 and two 90° fittings (16 and 20) from fuel day tank (4).
- g. Remove fittings (17 and 21) from 90° fittings (16 and 20).
- h. Clean old sealing compound from all fittings (7, 12, 17, 21) and 90° fittings (16 and 20).
- i. Apply sealing compound to threads of fittings (7 and 12) and install fittings into new fuel day tank.
- j. Apply sealing compound to threads of fittings (17 and 21) and install into 90° fittings (16 and 20).
- k. Slide fuel day tank (4) between engine and frame and align mounting holes with holes in frame assembly.
- l. Secure fuel day tank to frame with four bolts and lock washers (5).
- m. Install fuel lines on fuel day tank. Proceed as follows:
 - (1) Install vehicle return line (23) to fitting (21) and secure with clamp (22).
 - (2) Install overflow line (10) to fitting (12) and secure with clamp (11).
 - (3) Install fuel filter line (9) to fitting (7) and secure with clamp (8).
 - (4) Install transfer pump line (19) to fitting (17) and secure with clamp (18).
- n. Reconnect connector J7 (14) to connector P7 (15).
- o. Bleed fuel system (para 4.29.).
- p. Install radiator support bracket (3) and secure with two bolts and flat and lock washers (1) and two screws and flat and lock washers (2).

THIS PAGE INTENTIONALLY LEFT BLANK

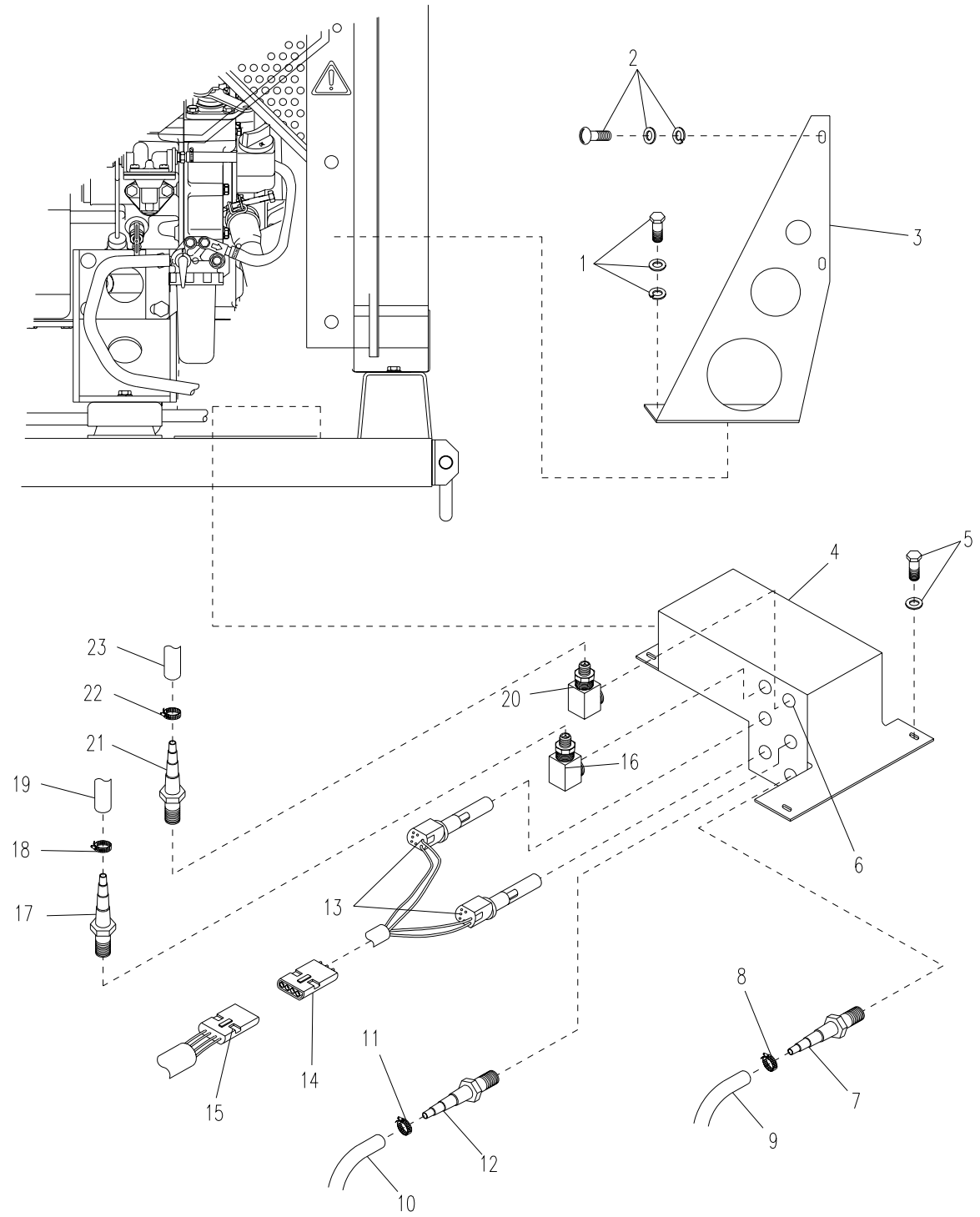

Figure 4-20. Fuel Day Tank Assembly (SICPS)

4.34. FUEL FEEDER PUMP.

This task covers: a. Test b. Replace

INITIAL SETUP

Tools

General Mechanic's Tool Kit
(Item 1, Appendix B)

Gloves, Chemical and Oil Protective
(Item 34, Appendix B)

Materials/Parts

Fuel Feeder Pump
Gasket
(Item 4, Appendix J)

Equipment Conditions

Engine stopped and allowed to cool completely.

MASTER ON-OFF switch on APU control unit set to OFF.

Personnel Required

Two

WARNING

Ensure that NO IGNITION SOURCE is within 50 feet of the 10 kW APU. The fuel in this APU is highly flammable. Do not smoke. Do not splash fuel on hot components. Failure to heed this warning could result in serious injuries to personnel or DEATH.

WARNING

Avoid fuel contact with skin. Wear protective gloves, goggles, apron and mask, while disconnecting fuel lines. Failure to heed this warning could result in serious injuries to personnel or DEATH.

TEST

NOTE

When removing fuel lines and fittings, have pan available to catch spilled fuel.

- a. Loosen clamp (6) and remove line (5) from fuel injection pump (7).

NOTE

Keep line attached to fuel feeder pump.

- b. Place pan under line (5, Figure 4-21) to receive fuel.
- c. On control unit, place MASTER ON-OFF switch to ON.
- d. Turn and hold the ENGINE START-PREHEAT switch to START.

- e. Observe fuel flow from fuel feeder pump (2). If no fuel is pumped out, pump is faulty. Replace fuel feeder pump.
- f. Release ENGINE START-PREHEAT switch and position MASTER ON-OFF switch to OFF.
- g. Install line (5) and secure to fuel injection pump (7) with clamp (6).
- h. Bleed fuel feeder pump at the injection pump. Refer to 4.29 (steps d, e, f and g).

REPLACE

- a. Loosen two clamps (4 and 9) and remove two fuel lines (5 and 8) from fuel feeder pump (2).
- b. Remove two bolts and lock washers (1) and remove fuel feeder pump (2) and gasket (3). Discard gasket (3).
- c. Thoroughly clean engine block.
- d. Install new gasket (3) and fuel feeder pump (2) onto engine block and secure with two bolts and lock washers (1).
- e. Install fuel lines (5 and 8) to new pump (2) and secure with two clamps (4 and 9).
- f. Bleed fuel feeder pump at the injection pump. Refer to 4.29 (steps d, e, f, and g).

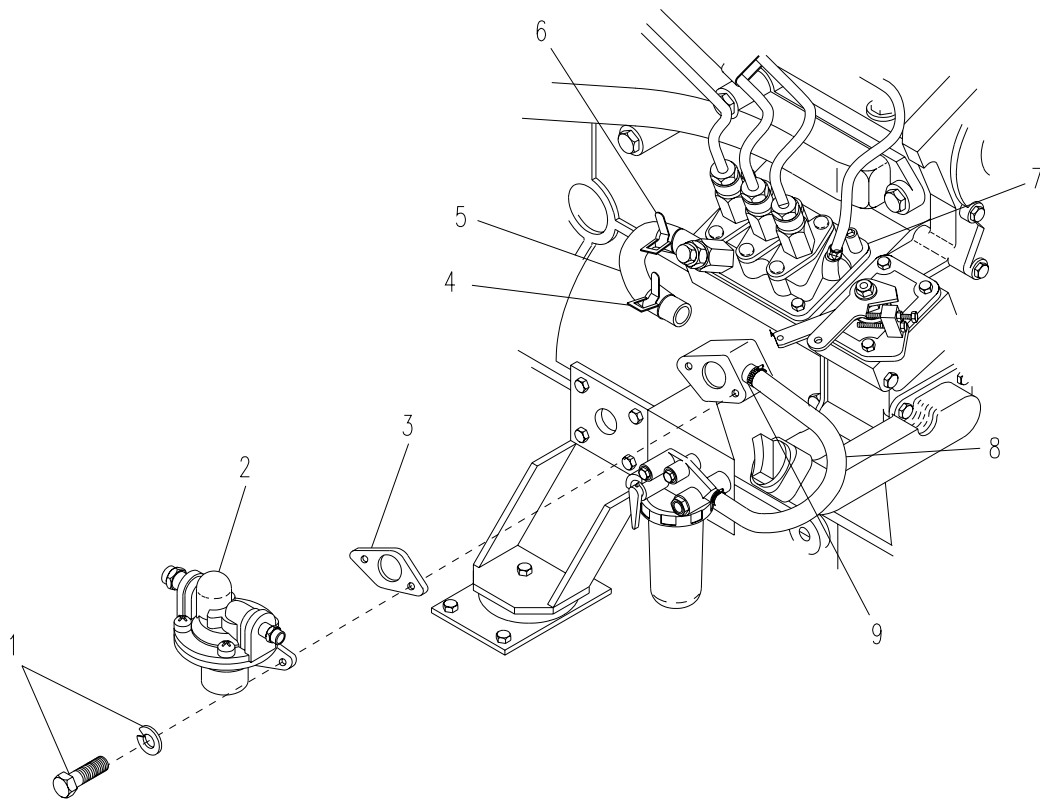

Figure 4-21. Fuel Feeder Pump

4.35. FUEL LINES AND FITTINGS (JTACS, SICPS, and WIN-T).

This task covers: a. Inspect b. Replace

INITIAL SETUP

Tools

General Mechanic's Tool Kit
(Item 1, Appendix B)

Gloves, Chemical and Oil Protective
(Item 34, Appendix B)

Materials/Parts

Fuel Lines
Fittings
Strap, Tiedown, Elect.
(Item 22, Appendix F)

Equipment Conditions

Engine stopped and allowed to cool completely.

MASTER ON-OFF switch on APU control unit set to OFF.

INSPECT

WARNING

Ensure that NO IGNITION SOURCE is within 50 feet of the 10 kW APU. The fuel in this APU is highly flammable. Do not smoke. Do not splash fuel on hot components. Failure to heed this warning could result in serious injuries to personnel or DEATH.

WARNING

Avoid fuel contact with skin. Wear protective gloves, goggles, apron and mask, while disconnecting fuel lines. Failure to heed this warning could result in serious injuries to personnel or DEATH.

- a. Inspect fuel lines for deterioration, crimping, corrosion, chafing, or damage.
- b. Replace all deteriorated, crimped, corroded, chafed, or damaged fuel lines.

REPLACE

CAUTION

Take care not to cut wires or other APU components when cutting and removing tiedown straps.

NOTES

Remove and replace only those lines that are determined to be defective during inspections.

When removing, make note of tiedown strap locations. Wiring harness will need to be secured at approximately the same places.

When disconnecting fuel lines, use a suitable container to catch fuel leaking from disconnected fuel lines.

- a. Loosen one clamp (26, Figure 4-22 (SICPS) or Figure 4-23 (JTACS and WIN-T)) and remove fuel line (27) from vehicle to fuel transfer pump (25).
- b. Loosen two clamps (20) and remove fuel line (21) from between fuel transfer pump (25) and day tank (16).
- c. Loosen two clamps (17) and remove fuel line (18) from between day tank (16) and fuel filter (15).
- d. Loosen two clamps (13) and remove fuel line (14) from between fuel filter (15) and feeder pump (19).
- e. Loosen two clamps (4) and remove fuel line (3) from between fuel feeder pump (19) and injection pump (22).
- f. Loosen one clamp (2) and remove return fuel line (1) from day tank (16) to vehicle.
- g. Loosen one screw (5) and loop clamp (6) and remove wiring harness (7).
- h. Install fuel line (24) between injection nozzles (8) and day tank (16) and two clamps (23).
- i. Install overflow fuel line (10) between injection pump (22) and injection nozzles (12) and secure with two clamps (11).
- j. Install three injection lines (8) between injection pump (22) and injection nozzles (12) and tighten pipe fittings (9).
- k. Install wiring harness (7) and secure with loop clamp (6) and screw (5).
- l. Install return fuel line (1) on day tank (16) and secure with one clamp (2).
- m. Install fuel line (3) between fuel feeder pump (19) and injection pump (22) and secure with two clamps (4).
- n. Install fuel line (14) between fuel filter (15) and feeder pump (19) and secure with two clamps (13).

- o. Install fuel line (18) between day tank (16) and fuel filter (15) and secure with two clamps (17).
- p. Install fuel line (21) between fuel transfer pump (25) and day tank (16) and secure with two clamps (20).
- q. Install fuel line (27) on fuel transfer pump (25) and secure with one clamp (26).
- r. Do bleed procedures (para 4.29) based on maintenance procedures performed.

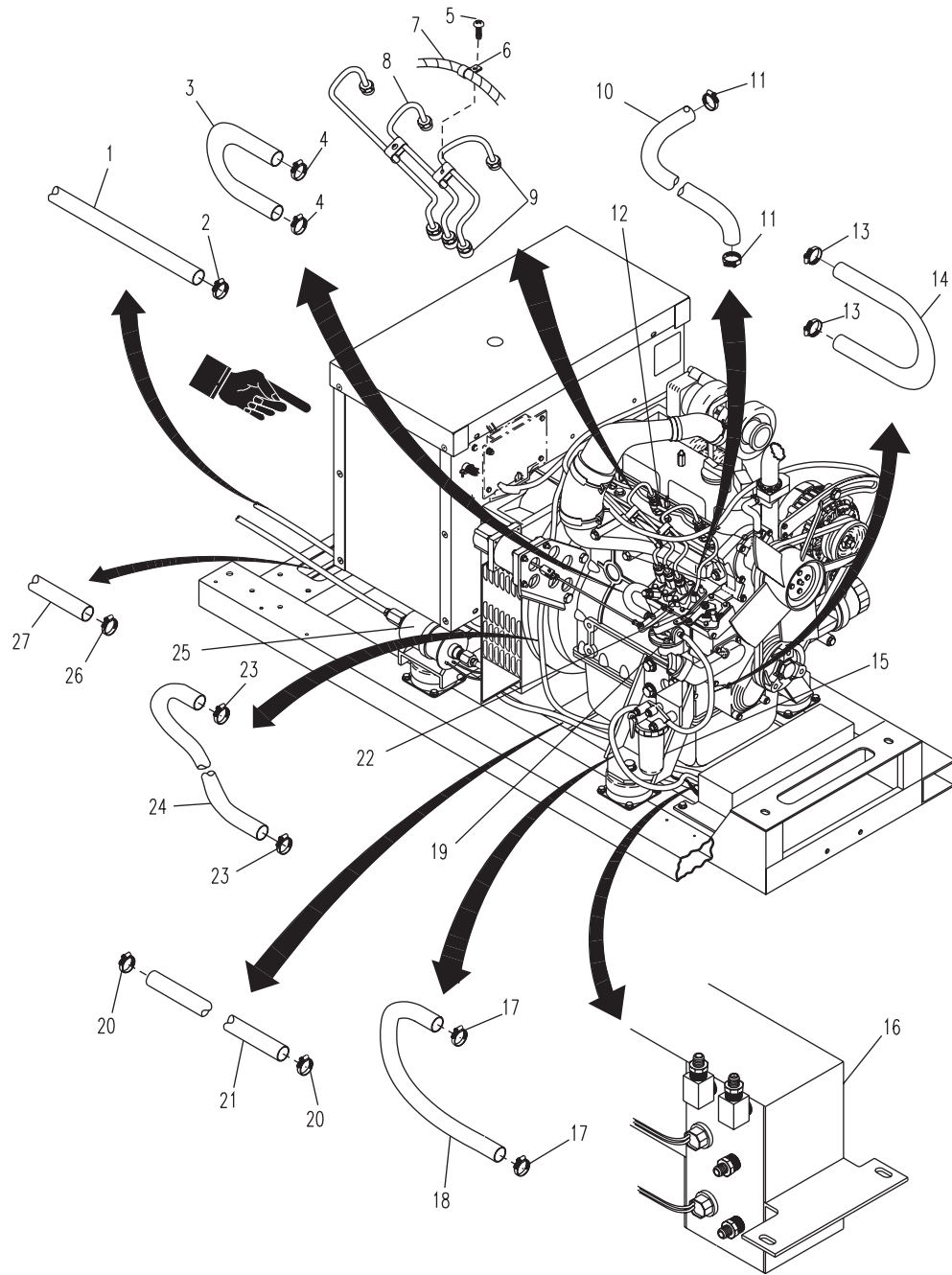

Figure 4-22. Fuel Lines and Fittings (SICPS)

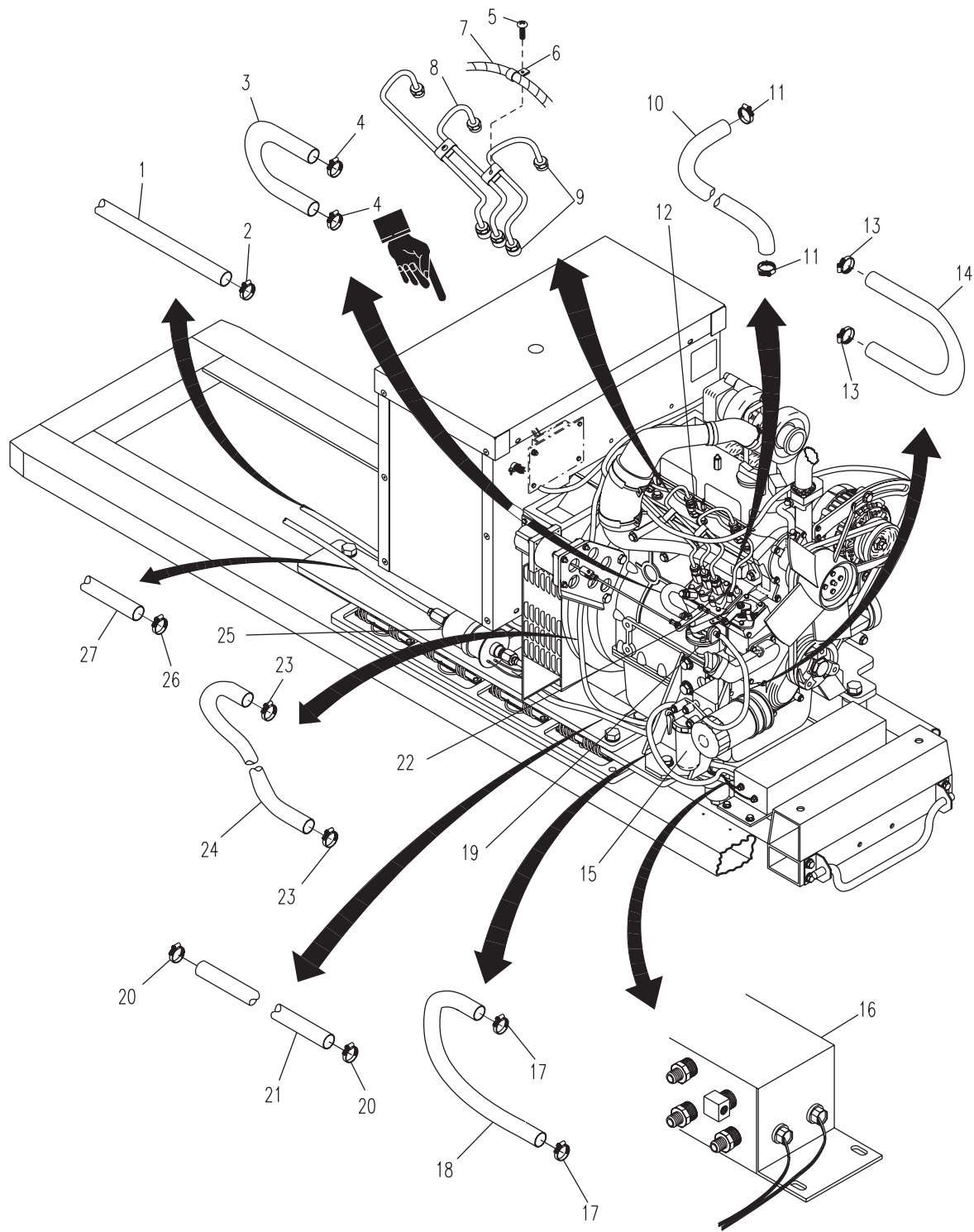

Figure 4-23. Fuel Lines and Fittings (JTACS and WIN-T)

4.36. BATTERY CHARGING ALTERNATOR.

This task covers: a. Test b. Replace

INITIAL SETUP

Tools

General Mechanic's Tool Kit
(Item 1, Appendix B)

Shop Equipment, Electrical Repair,
Semitrailer Mounted
(Item 3, Appendix B)

Materials/Parts

Battery Charging
Alternator

Strap, Tiedown, Elect.
(Item 22, Appendix F)

Equipment Conditions

Vehicle engine not running.

MASTER ON-OFF switch on APU control unit set to OFF.

Fan guard, fan shroud, and shroud housing removed (para 4.18.).

TEST

- a. Refer to Figure FO-1 (SICPS/WIN-T) or F0-7 (JTACS) and tag and remove connector lead AF (2, Figure 4-24) from battery charging alternator (1).
- b. Pull back protective cover and remove nut and washer (5) securing lead ALT (4) to alternator (1). Tag and remove lead (4).
- c. Start APU (para 2.5.).
- d. Using a multimeter, connect positive lead to alternator lead ALT (3) and negative lead to ground.
- e. Measure voltage reading. If alternator voltage reading is below 20 VAC, or there is no reading, alternator is faulty.
- f. Stop APU (para 2.6.) and replace alternator.

REPLACE

WARNING

Ensure that APU DC power supply is disconnected. Failure to observe this warning could result in severe injury or DEATH to personnel.

WARNING

Ensure that the APU is turned off and completely de-energized before opening generator housing. Failure to observe this warning could result in severe injury or DEATH to personnel.

CAUTION

Take care not to cut wires or other APU components when removing tiedown straps.

NOTE

Cut and remove tiedown straps as needed to remove wiring harness.

NOTE

When removing, make note of tiedown strap locations. Wiring harness will need to be secured at approximately the same places.

- a. Refer to Figure FO-1 (SICPS/WIN-T) or F0-7 (JTACS) and tag and remove connector lead AF (2) from alternator.
- b. Pull back protective cover and remove nut and washer (5) securing connector lead ALT (4) to alternator (1). Tag and remove lead.
- c. Remove bolt and lock washer (15) securing alternator to adjusting bracket (14).
- d. Remove bolt (13), washer (12), spacer (10), breather tube brace (6), lock washer (8), and nut (7) and remove alternator (1).
- e. Remove fan belt (para 4.23.).
- f. Align lower hole in alternator with hole in front mounting bracket (9) and install spacer (10).
- g. Align washer (12) with hole in front mounting bracket (11) and insert bolt (13) through washer (12), front mounting bracket (11), lower hole in alternator, spacer (10), and rear mounting bracket (9).
- h. Install breather tube brace (6 and 1), lock washer (8), on bolt (13) and secure with nut (7).
- i. Secure upper hole in alternator (1) to adjusting bracket (14) with bolt and lock washer (15).
- j. Secure connector lead ALT (4) to alternator (1) and secure with washer and nut (5). Remove tag. Install protective cover.
- k. Secure connector lead AF (2) to alternator. Remove tag.
- l. Install and adjust fan belt (para 4.23).

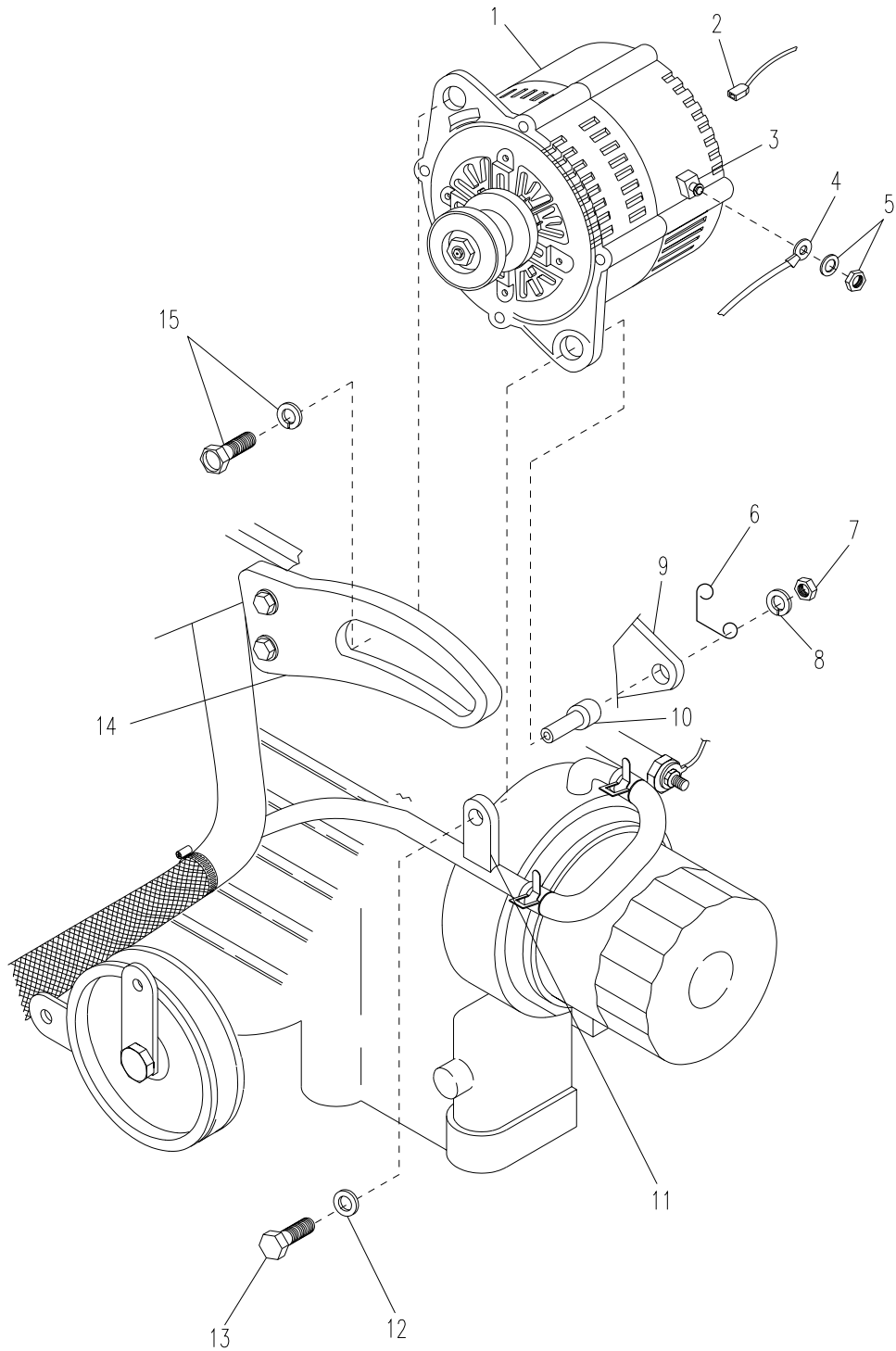

Figure 4-24. Battery Charging Alternator

4.37. STARTER.

This task covers: a. Test b. Replace

INITIAL SETUP

Tools

Shop Equipment, Electrical Repair,
Semi Trailer Mounted
(Item 3, Appendix B) including Test Stand,
Automotive Generator

Equipment Conditions

Vehicle engine not running.

MASTER ON-OFF switch on APU control unit set to
OFF.

Materials/Parts

Starter

TEST

- a. Remove starter (perform steps a through d of REPLACE).
- b. Use test stand to test starter.
- c. If starter does not turn over, replace starter.

REPLACE

WARNING

Ensure that APU DC power supply is disconnected. Failure to observe this warning could result in severe injury or DEATH to personnel.

WARNING

Ensure that the APU is turned off and completely de-energized. Failure to observe this warning could result in severe injury or DEATH to personnel.

- a. Pull back protective cover and remove one nut and lock washer (3, Figure 4-25) and tag. Remove leads SB (4) and positive (4) lead (7) from battery to starter.
- b. Remove lead STR (5) from starter (2).

NOTE

A bad solenoid causes poor engagement at starter gears and the flywheel (6). While starter is removed, inspect flywheel (6) for chipped or missing gear teeth. Notify the next higher level of maintenance if chipped or missing gear teeth exist.

- c. Remove two screws and lock washers (1) and remove starter (2) from engine bell housing.
- d. Install new starter (2) and secure to engine bell housing with two lock washers and screws (1).

- e. Connect lead STR (5) to starter (2).
- f. Connect lead SB (4) to starter (2) and secure with lock washer and nut (3). Replace protective cover.

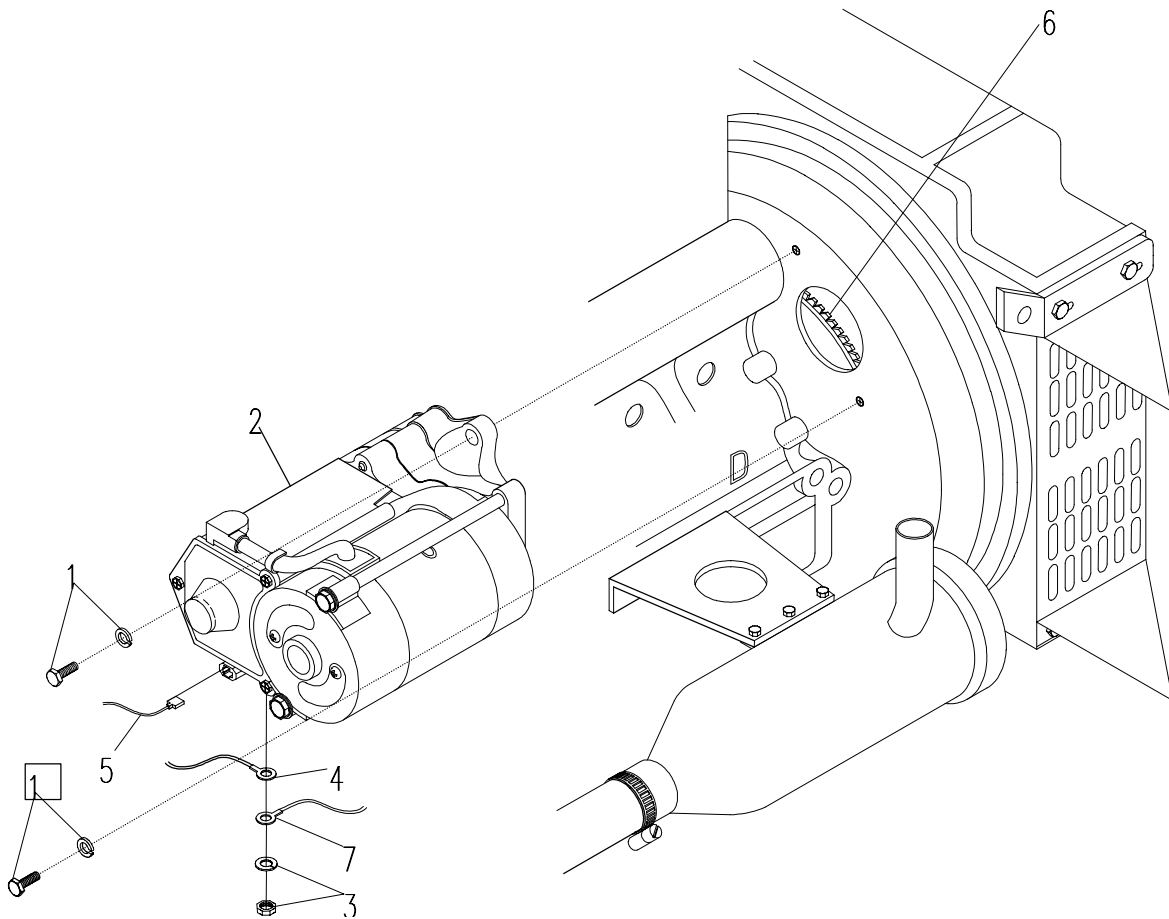

Figure 4-25. Starter

4.38. GLOW PLUG.

This task covers: a. Test b. Replace

INITIAL SETUP

Tools

General Mechanic's Tool Kit
(Item 1, Appendix B)

Multimeter

Torque Wrench
(Item 2, Appendix B)

Shop Equipment, Electrical Repair,
Semi trailer Mounted
(Item 3, Appendix B)

Materials/Parts

Engine Glow Plugs
Manifold Glow Plug

Equipment Conditions

MASTER ON-OFF switch on APU control unit set to OFF.

Engine stopped and allowed to cool completely.

TEST

- a. Remove glow plugs (perform steps a through f of REPLACE procedure).
- b. Measure resistance across glow plug terminal and glow plugs and ground. Resistance should be between 4.9 and 5.2 ohms.
- c. If 0 ohm is indicated, there is a short between the terminal of the glow plug and the housing. Replace the glow plug.

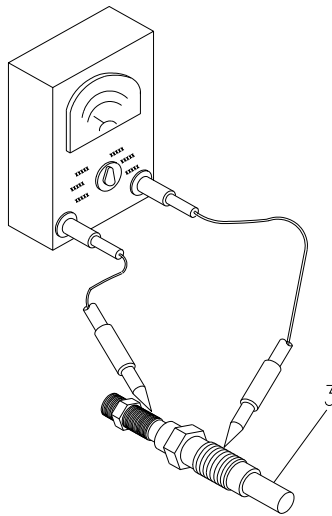

Figure 4-26. Glow Plug (Sheet 1 of 2)

REPLACE

NOTE

The APU contains four glow plugs. Three are used to heat the engine cylinders. The other is used as an intake manifold heater.

- a. Remove three nuts (4, Figure 4-26) securing bus bar (6) to engine glow plugs (8).
- b. Tag and remove lead (5).
- c. Remove bus bar (6) and three washers (7).

WARNING

Compressed air shall not be used for cleaning purposes except where reduced to less than 29 pounds per square inch gauge (psig) (199.94 kPa) and then only with effective chip guarding and personnel protective equipment. Compressed air is dangerous and can cause serious bodily harm if protective means or methods are not observed to prevent chip or particle (of whatever size) from being blown into the eyes or unprotected skin of the operator or other personnel.

- d. Using compressed air, thoroughly clean area around engine glow plugs.
- e. Remove three engine glow plugs (8).
- f. Remove nut (1) securing lead to intake glow plug (3). Tag and remove lead (2).
- g. Remove intake glow plug and washer (3).
- h. Install three engine glow plugs (8). Torque between 5.8 and 10.8 ft-lbs (7.8 and 14.7 Nm).
- i. Install three washers (7) and bus bar (6) on engine glow plugs.
- j. Install lead (5) on bus bar (6). Remove tag.
- k. Secure bus bar (6) to engine glow plugs (8) with three nuts (4).
- l. Install intake glow plug and washer (3) and torque between 28.9 and 32.5 ft-lbs (39.2 and 44.1 Nm).
- m. Install lead (2) on intake glow plug (3) and secure with one nut (1). Remove tag.

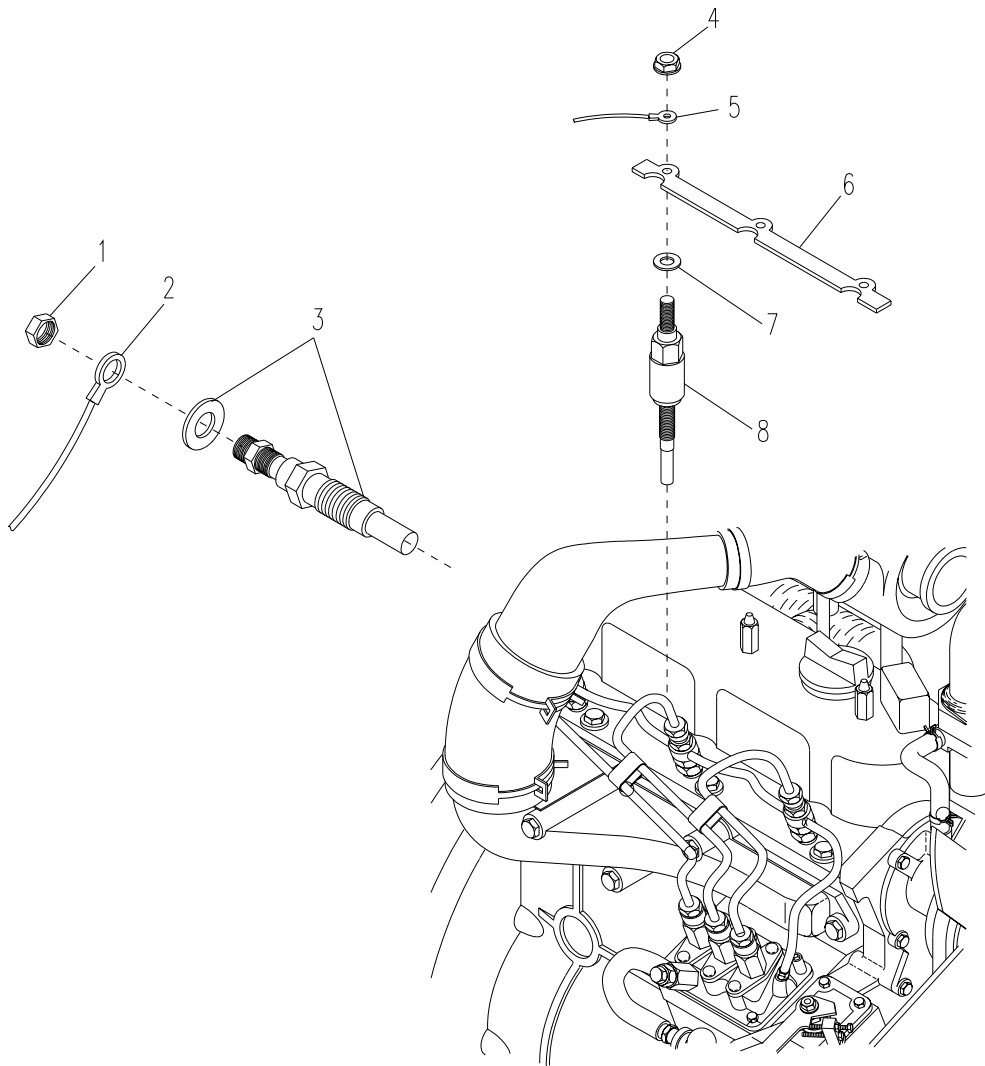

Figure 4-26. Glow Plug (Sheet 2)

4.39. MUFFLER WRAP.

This task covers: Replace

INITIAL SETUP

ToolsGeneral Mechanic's Tool Kit
(Item 1, Appendix B)Gloves, Chemical and Oil Protective
(Item 34, Appendix B)Materials/Parts

Muffler Wrap (SICPS)

Muffler Wrap (WIN-T)

Muffler Wrap (JTACS)

Safety Wire
(Item 16, Appendix F)

Equipment Conditions

MASTER ON-OFF switch on APU control unit set to OFF.

Engine stopped and allowed to cool completely.

REPLACE

CAUTION

Muffler wrap contains fiberglass. Wear a long sleeved shirt and gloves and a mask when removing the muffler wrap.

- a. Remove all safety wires (2, Figure 4-27) from four hooks and buttons (SICPS) or three hooks and buttons (WIN-T and JTACS) (3) securing muffler wrap (1).
- b. Remove muffler wrap (1).
- c. Install new muffler wrap (1) and secure using four hooks and buttons (SICPS), three hooks and buttons (WIN-T and JTACS) (3), and safety wires (2).
- d. Reinstall bracket (2) on muffler wrap (1).

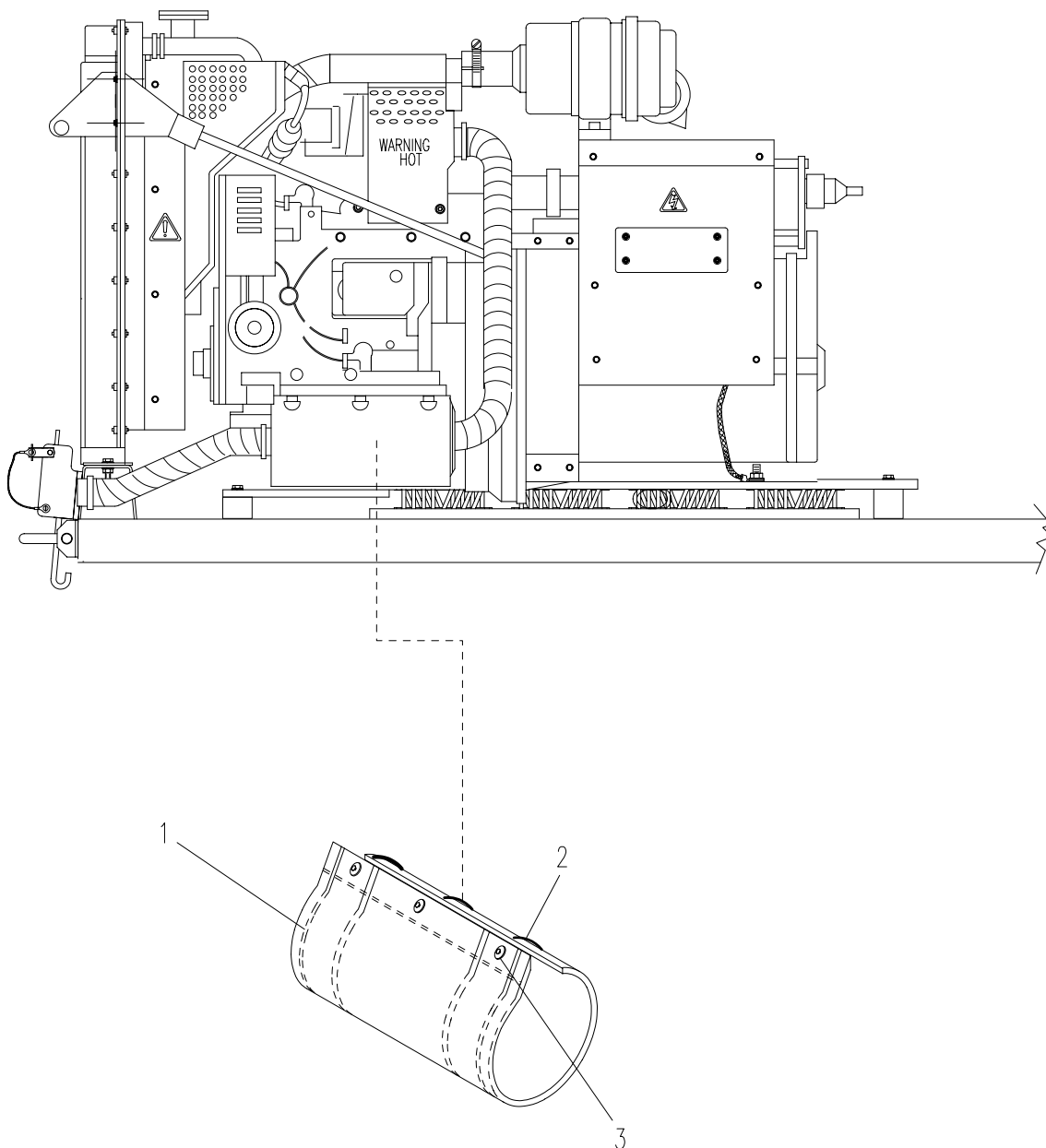

Figure 4-27. Muffler Wrap

4.40. MUFFLER, (JTACS) MODEL MEP-903B and (WIN-T), MODEL MEP-903C.

This task covers: a. Service b. Replace

INITIAL SETUP

Tools

General Mechanic's Tool Kit
(Item 1, Appendix B)

Gloves, Mask, Chemical and Oil Protective
(Item 34, Appendix B)

Materials/Parts

Muffler (JTACS and WIN-T)
Muffler Gasket
(Item 7, Appendix J)

Equipment Conditions

MASTER ON-OFF switch on APU control unit set to OFF.

Engine stopped and allowed to cool completely.

Muffler wrap removed (para 4.39.).

WARNING

DC voltages are present at generator set components. Even with generator set shutdown. Avoid grounding self when touching any electrical components. Failure to observe this warning can result in personal injury or DEATH by electrocution.

SERVICE

NOTE

Lengths of mufflers vary between JTACS and WIN-T models. They are attached to the APU in the same manner.

CAUTION

Exhaust pipe wrap contains fiberglass. Wear a long-sleeved shirt and gloves, and mask, when removing the muffler wrap.

- a. Remove one bolt and lock washer (1) securing muffler (6) to muffler bracket (2), remove three bolts and washers (3, Figure 4-28) securing muffler (6) to muffler brace (4). Remove muffler (6) and muffler gasket (5).

WARNING

Do not use solvents to clean interior of muffler.

- b. Clean muffler by mechanically removing carbon and fuel residues from input and exhaust pipe openings in muffler.
- c. Reinstall muffler (6) and muffler gasket (5) to muffler brace (4) and secure with three bolts and three washers (3).
- d. Secure muffler (6) to muffler bracket (2) with one bolt and lock washer (1).

REPLACE

- a. Remove one bolt and lock washers (1) and two bolts (7) securing muffler (6) to muffler bracket (2), remove three bolts and washers (3, Figure 4-28) securing muffler (6) to muffler brace (4). Remove muffler (6) and muffler gasket (5).
- b. Remove hose clamp loops (8) and exhaust pipe insulating wrap from muffler exhaust pipe. Discard muffler and gasket.
- c. Install new muffler (6) and muffler gasket (5) to muffler brace (4) and secure with three bolts and washers (3).
- d. Install exhaust pipe insulating wrap on muffler (6) and secure with loop clamps (8) on both ends.
- e. Secure muffler (6) to muffler bracket (2) with one bolt and lock washers (1) and two bolts (7).
- f. Install muffler wrap (para 4.42.).
- g. Install bracket on muffler wrap.

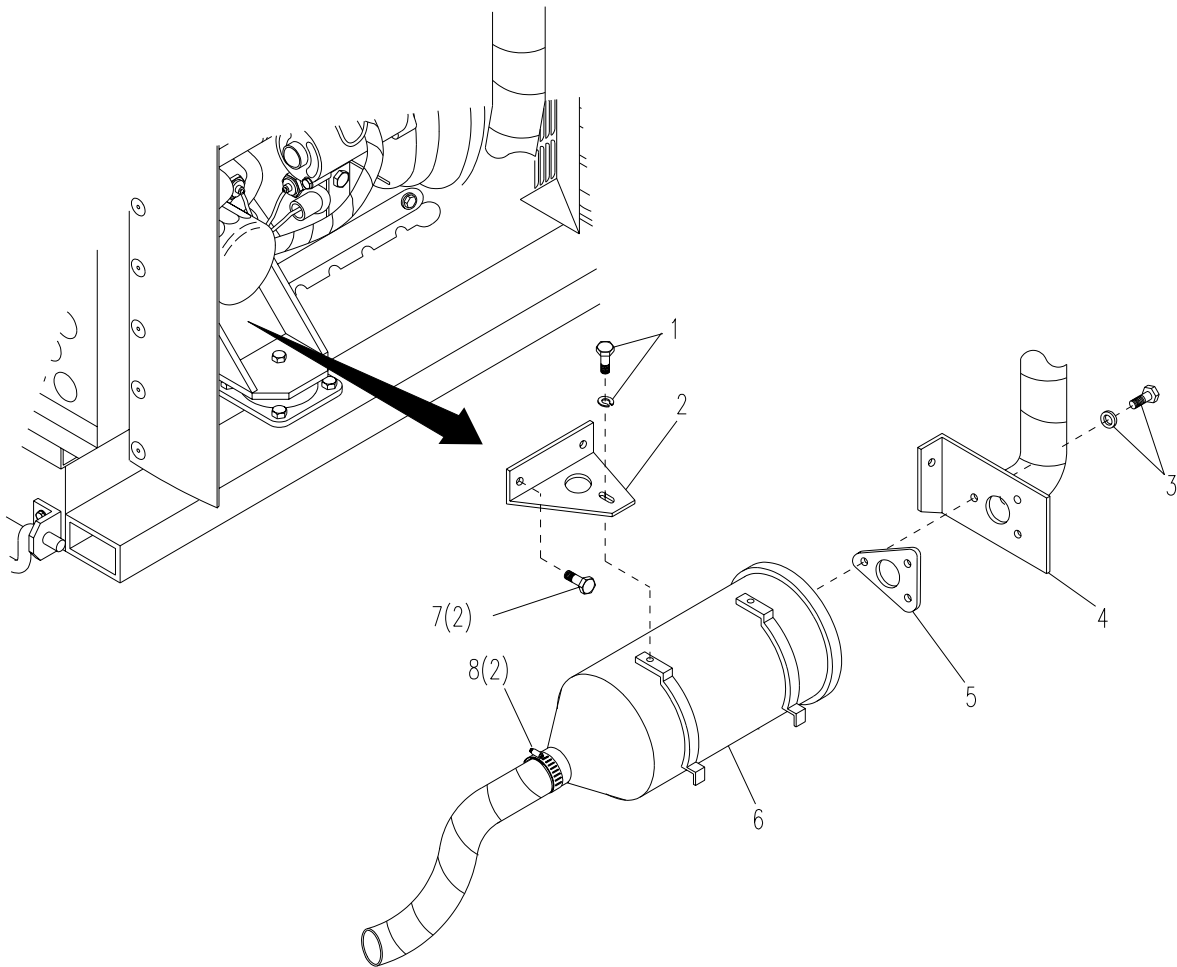

Figure 4-28. Muffler (JTACS and WIN-T)

4.41. MUFFLER (SICPS), MODEL MEP-903A.

This task covers: a. Service b. Replace

INITIAL SETUP

Tools

General Mechanic's Tool Kit
(Item 1, Appendix B)

Equipment Conditions

MASTER ON-OFF switch on APU control unit set to OFF.

Engine stopped and allowed to cool completely.

Muffler wrap removed (para 4.39.).

Materials/Parts

Muffler (SICPS)

WARNING

DC voltages are present at generator set components, even with generator set shutdown. Avoid grounding self when touching any electrical components. Failure to observe this warning can result in personal injury or DEATH by electrocution.

SERVICE

CAUTION

Exhaust pipe wrap contains fiberglass. Wear a long-sleeved shirt, gloves, and mask, when removing the muffler wrap.

- a. Remove three bolts, lock washers and flat washers (1, Figure 4-29) securing muffler (6) to muffler bracket (4), remove exhaust loop pipe clamp (3) securing muffler to exhaust pipe (2) and remove exhaust pipe insulating wrap around exhaust pipe (2). Remove muffler (6).
- b. Remove hose clamp loops (8) and exhaust pipe insulating wrap from muffler exhaust pipe.

WARNING

Do not use solvents to clean interior of muffler.

- c. Clean muffler by mechanically removing carbon and fuel residues from input and exhaust pipe openings in muffler.

- d. Wrap exhaust pipe wrap around exhaust pipe (2) and install hose clamp loops (8).
- e. Reinstall muffler (6) by securing muffler pipe (5) to exhaust pipe clamp (2) with pipe clamp (3). Install muffler (6) to muffler bracket (4) with three bolts and lock washers and flat washers (1).

REPLACE

- a. Remove three bolts, lock washers and flat washers (1, Figure 4-29) securing muffler (6) to muffler bracket (4), remove exhaust pipe clamps (3) securing muffler to exhaust pipe (2) and remove exhaust pipe insulating wrap around exhaust pipe (2). Remove muffler (6).
- b. Remove hose clamp loops (8) and exhaust pipe insulating wrap from muffler exhaust pipe.
- c. Ensuring exhaust pipe (2) is inserted in muffler pipe (5), install new muffler (6) to muffler bracket (4) and secure with three bolts, lock washers, and flat washers (1).
- d. Install exhaust pipe insulating wrap around new exhaust pipe (2) and install hose clamp loops (8).
- e. Secure exhaust pipe (2) to muffler pipe (5) with muffler clamp loop (3).
- f. Install muffler wrap (Para 4.39.).

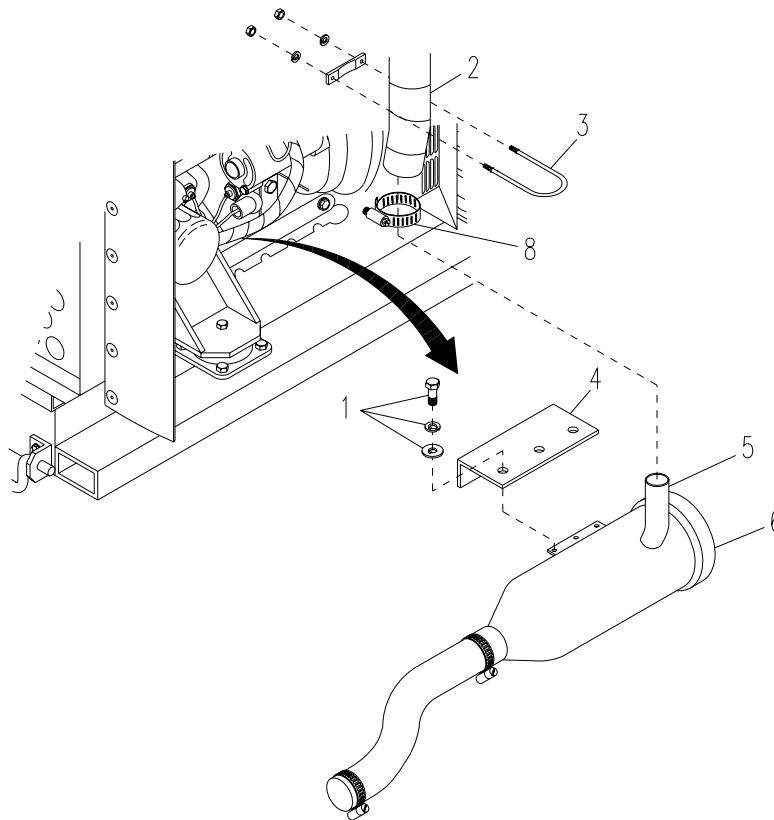

Figure 4-29. Muffler (SICPS)

4.42. EXHAUST PIPE, (JTACS) MODEL MEP-903B and (WIN-T) MODEL MEP-903C.

This task covers: Replace

INITIAL SETUP

Tools

General Mechanic's Tool Kit
(Item 1, Appendix B)

Equipment Conditions

MASTER ON-OFF switch on APU control unit set to OFF.

Engine stopped and allowed to cool completely.

Materials/Parts

Muffler Gasket
(Item 7, Appendix J)

Flange Gasket
(Item 18, Appendix J)

Exhaust Pipe (JTACS and WIN-T)

REPLACE

- a. Remove three bolts and lock washers (4, Figure 4-30) and one bolt and lock washer (7) from muffler bracket (5).
- b. Remove four nuts and lock washers (JTACS) (3) or four bolts and lock washers (WIN-T) (3a) securing exhaust pipe (1) and flange gasket (9) to turbocharger (8).
- c. Remove air intake pipe (para 4.47.).

NOTE

All hardware securing turbo guard (2) is now removed.

- d. Remove turbo guard (2).
- e. Remove exhaust pipe (1), muffler gasket (6), and flange gasket (9).
- f. Install new exhaust pipe (1), muffler gasket (6), and flange gasket (9) and secure with three bolts and lock washers (4) and one bolt and lock washer (7).
- g. Install turbo guard (2).
- h. Install air intake pipe (para 4.47.).
- i. Secure exhaust pipe (1), air intake pipe and turbo guard (2) with four lock washers and nuts (3).

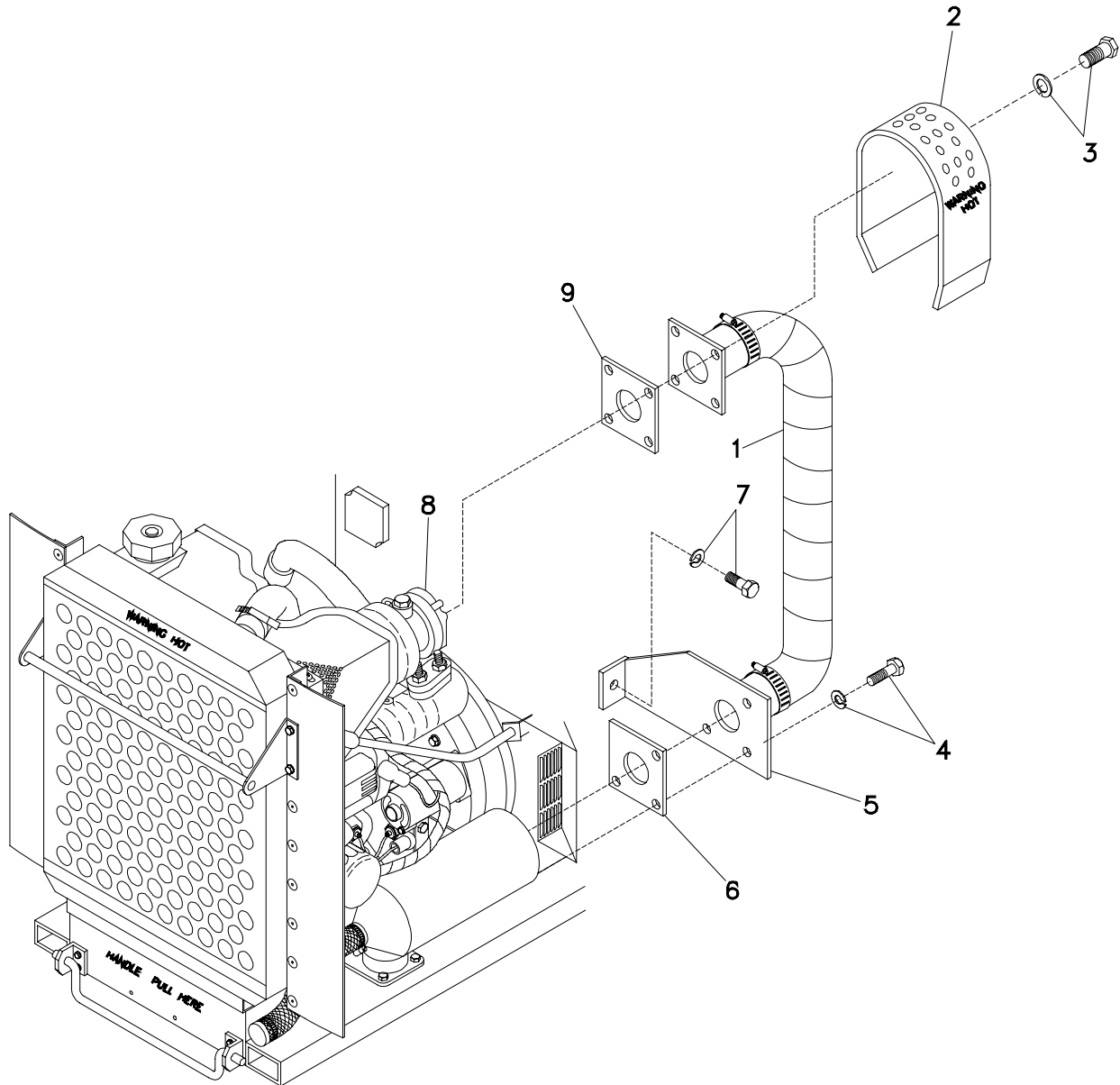

Figure 4-30. Exhaust Pipe (JTACS and WIN-T)

4.43. EXHAUST PIPE (SICPS), MODEL MEP-903A.

This task covers: Replace

INITIAL SETUP

Tools

General Mechanic's Tool Kit
(Item 1, Appendix B)

Equipment Conditions

MASTER ON-OFF switch on APU control unit set to OFF.

Materials/Parts

Engine stopped and allowed to cool completely.

Exhaust Pipe (SICPS)

REPLACE

- a. Remove muffler loop clamp (4, Figure 4-31) securing exhaust pipe (1) to muffler.
- b. Remove wrap.
- c. Remove four bolts and lock washers (3) securing exhaust pipe (1) to turbocharger.
- d. Remove air intake pipe (para 4.47.).

NOTE

Hardware securing turbo guard (2) is now removed.

- e. Remove turbo guard (2).
- f. Remove exhaust pipe (1) and flange gasket (5).
- g. Install exhaust pipe (1) and flange gasket (5). Rewrap exhaust pipe and secure to muffler with muffler loop clamp (4).
- h. Install turbo guard (2).
- i. Install air intake pipe (para 4.47.).
- j. Secure exhaust pipe, air intake pipe, and turbo guard with four lock washers and bolts (3).

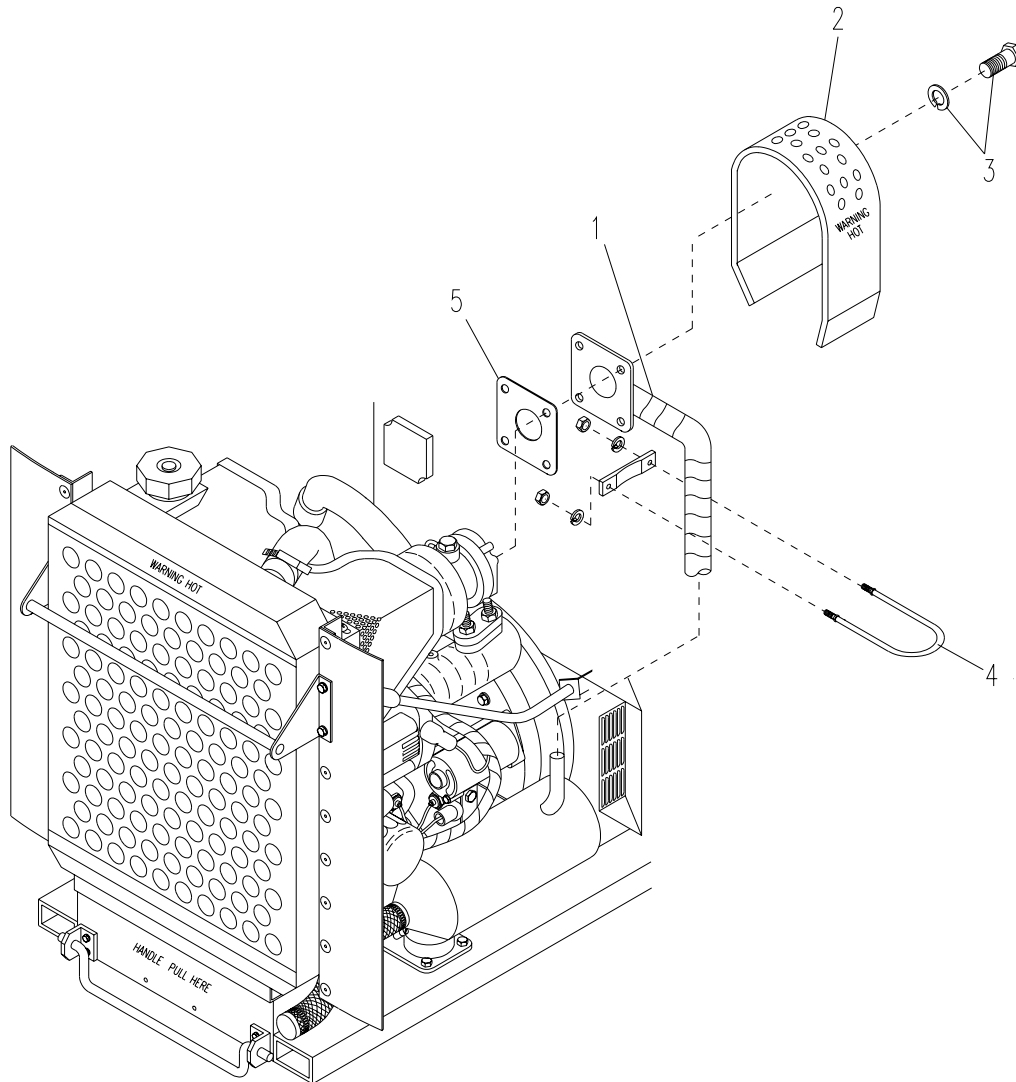

Figure 4-31. Exhaust Pipe (SICPS)

4.44. ENGINE TURBOCHARGER.

This task covers: Replace

INITIAL SETUP

Tools

General Mechanic's Tool Kit
(Item 1, Appendix B)

Materials/Parts

Turbocharger
Air Intake Hose
Manifold Intake Hose
Clamps
Sealing Washers
Turbocharger Gasket
(Item 17, Appendix J)
Oil Gasket, Turbocharger
(Item 16, Appendix J)

Equipment Conditions

Engine stopped and allowed to cool completely.

MASTER ON-OFF switch on APU control unit set to OFF.

Exhaust pipe removed (para 4.42. or 4.43.).

REPLACE

- a. Loosen clamp (7, Figure 4-32) and remove air intake elbow (8).
- b. Loosen clamp (2) and remove manifold intake hose (1).
- c. Remove banjo bolt (15) and two sealing washers (4) from oil pressure line (14).
- d. Remove two bolts and lock washers (10), oil drain hose (11), and oil gasket (12). Discard gasket (12).
- e. Remove three nuts (5) and sealing washers (6).
- f. Remove turbocharger (3) and gasket (9) from exhaust manifold mounting studs (13). Discard turbocharger (3) and gasket (9).
- g. Install new turbocharger (3) and gasket (9) on exhaust manifold mounting studs (13).
- h. Install three nuts (5) and sealing washers (6) and torque to 30 ft-lbs.
- i. Install oil drain hose (11) and new oil gasket (12) and secure with two bolts and lock washers (10).
- j. Install sealing washers (4) and banjo bolt (15) through hole in oil pressure line (14) into turbocharger (3).
- k. Install manifold intake hose (1) and secure with clamp (2).
- l. Install air intake elbow (8) and secure with clamp (7).

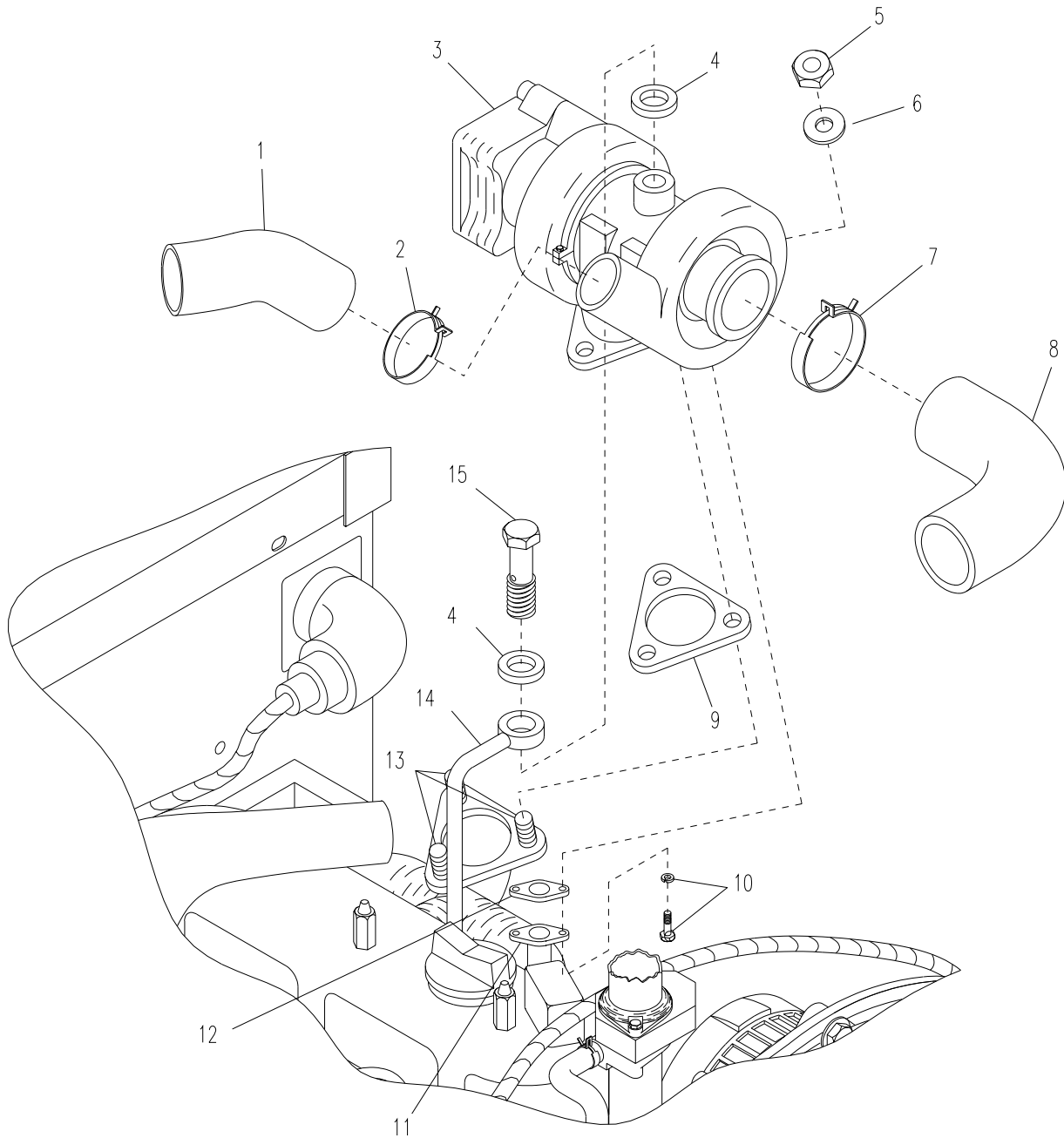

Figure 4-32. Engine Turbocharger

4.45. AIR FILTER (SICPS, JTACS, AND WIN-T).

This task covers: a. Inspect b. Service c. Replace

INITIAL SETUP

Tools

General Mechanic's Tool Kit
(Item 1, Appendix B)

Equipment Conditions

MASTER ON-OFF switch on APU control unit
set to OFF.

Materials/Parts

Air Filter

INSPECT

- a. Inspect Air Flow Restriction Indicator. If indicator shows restriction (indicator is red) or continues to show restriction (red) after button on indicator is pressed, service or replace filter.

SERVICE

- a. Open air filter housing (1) by unbuckling two buckles (2) on outside of case. Remove end cover (3) of air filter housing and take out filter element (8).
- b. Inspect element for dirt, oil and other contaminants.
- c. Clean the air filter element (8) with compressed air by blowing air from the inside out. If filter element is still contaminated with dirt and oil after cleaning, replace the filter element.

WARNING

Compressed air shall not be used for cleaning purposes except where reduced to less than 29 pounds per square inch gauge (psig) (199.94 kPa) and then only with effective chip guarding and personnel protective equipment. Compressed air is dangerous and can cause serious bodily harm if protective means or methods are not observed to prevent chip or particle (of whatever size) from being blown into the eyes or unprotected skin of the operator or other personnel.

NOTE

Air pressure at the nozzle must not exceed 100 psi (7kgf/cm²).

- d. Install the air filter element (8).
- e. Install filter end cover (3) and close buckles (2) on outside of case.

REPLACE

- a. Remove two slotted hex machine bolts, flat washers and lock washers (4) securing air filter mounting bracket (9) to top of generator cover.

- b. Loosen clamp (5), and remove air filter (1) off air intake pipe (6) by hand.
- c. Install the air filter (1) on the air intake pipe (6) and secure with clamp (5).
- d. Install two slotted hex machine bolts, flat washers and lock washers (4) securing air filter mounting bracket (9) to top of generator cover.

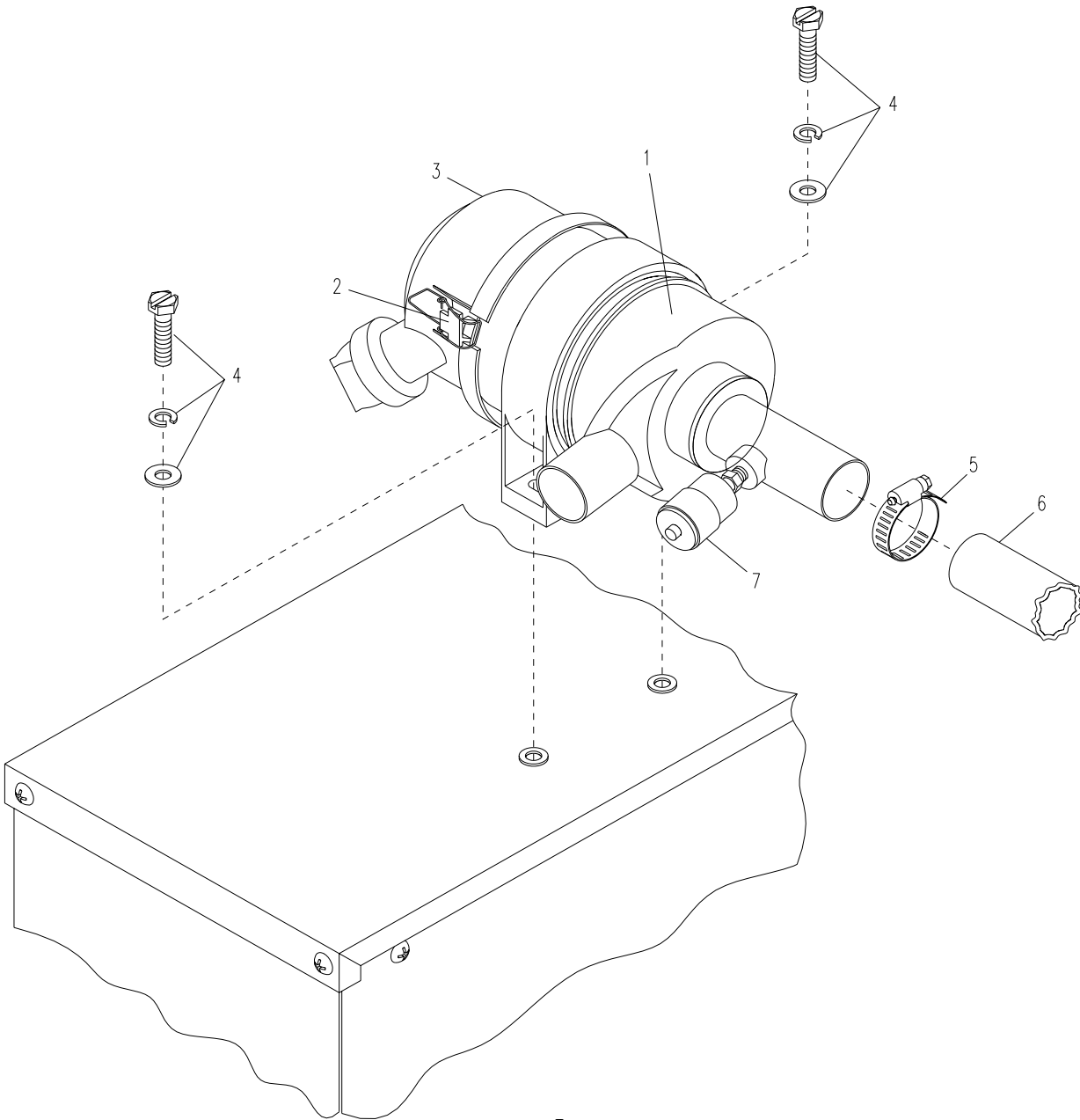

Figure 4-33. Air Filter (Sheet 1 of 2)

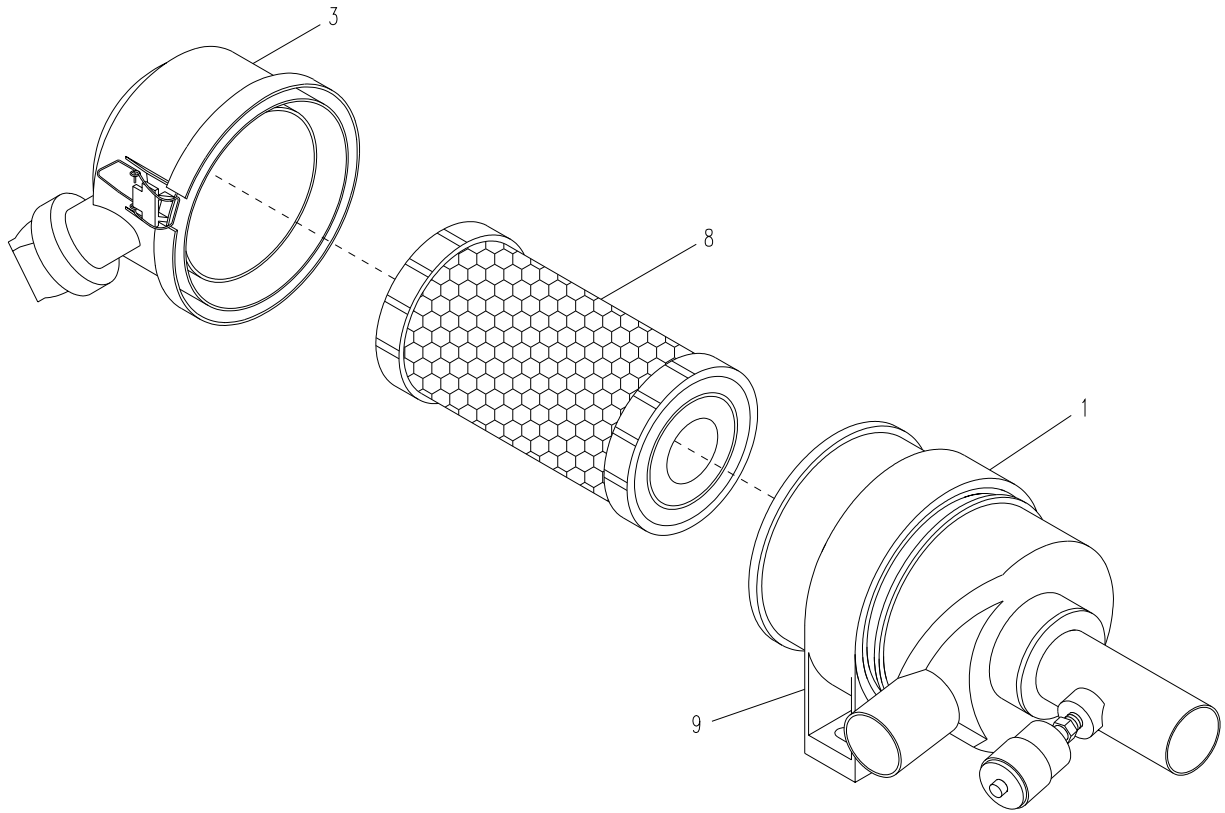

Figure 4-33. Air Filter (Sheet 2)

4.46. DELETED.

CONTENTS OF THIS PAGE DELETED.

4.47. AIR INTAKE PIPE.

This task covers: a. Inspect b. Replace

INITIAL SETUP

Tools

General Mechanic's Tool Kit
(Item 1, Appendix B)

Equipment Conditions

Engine stopped and allowed to cool completely.

MASTER ON-OFF switch on APU control unit set to OFF.

Materials/Parts

Air filter removed (para 4.45.).

Air Intake Pipe
Air Intake Hose
Hose Clamps

INSPECT

Inspect air intake elbow (5, Figure 4-35) and replace if showing signs of deterioration.

REPLACE

- a. Remove two nuts and lock washers (1, Figure 4-35) securing support bracket (2) to turbo charger (7).
- b. Loosen clamp (4) and remove air intake pipe (3) from air intake elbow (5).
- c. Loosen clamp (6) and remove air intake elbow (5) from turbo charger (7).
- d. Secure air intake elbow (5) to turbocharger (7) with clamp (6).
- e. Secure air intake pipe (3) to air intake elbow (5) with clamp (4).
- f. Secure support bracket (2) to turbocharger (7) with two lock washers and nuts and bolts (1).

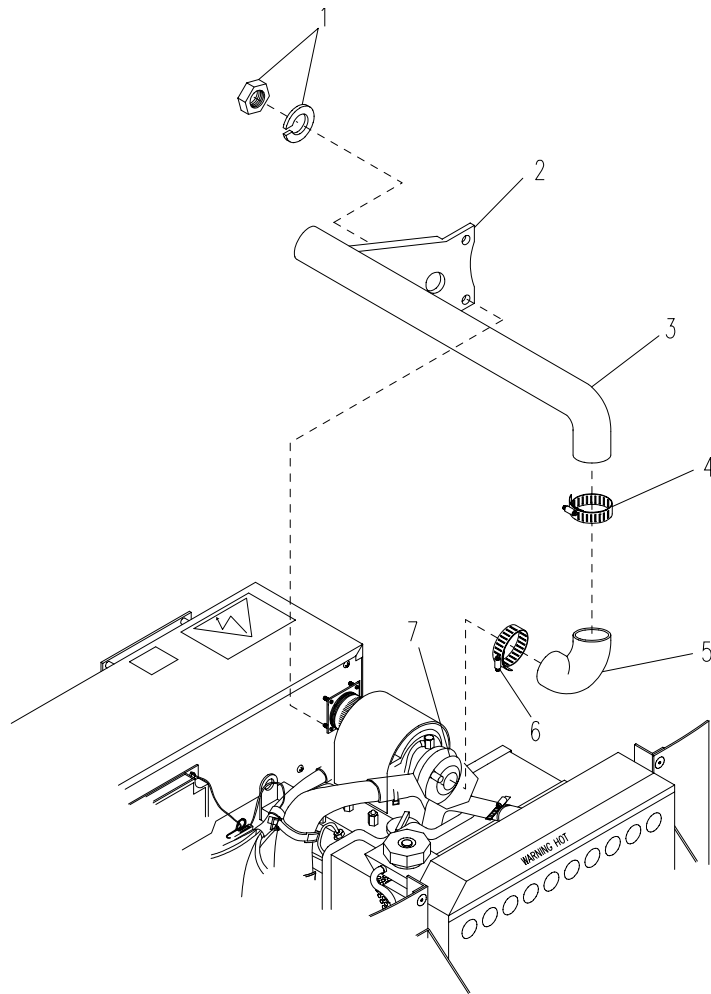

Figure 4-35. Air Intake Pipe

4.48. GOVERNOR CONTROL ASSEMBLY.

This task covers: a. Test b. Replace

INITIAL SETUP

Tools

Shop Equipment, Electrical Repair, Semitrailer Mounted (Item 3, Appendix B)

Equipment Conditions

MASTER ON-OFF switch on APU control unit set to off.

Materials/Parts

Air filter removed (para 4.45.).

Multimeter

WARNING

Governor Control Assembly

DC voltages are present at generator set components even with generator set shutdown. Avoid grounding self when touching any electrical components. Failure to observe this warning can result in personal injury or DEATH by electrocution.

TEST

NOTE

In order to avoid a low fuel fault shutdown of the APU, testing time shall not exceed three minutes maximum.

- a. Remove top cover (18, Figure 4-36).
- b. Tag and remove electrical leads P7 (7, Figure 4-19) from J7 (6).
- c. Attach multimeter leads to pins A and B of P7 (7).
- d. Start APU (para 2.5.). Check for voltage.
- e. After engine speed has stabilized, move control arm on governor to vary engine speed. Multi-meter should read between 24 and 28 VDC. If multimeter does not read between 24 and 28 VDC, governor control is faulty. Shut down APU (para 2.6.) and replace governor control assembly.

REPLACE

WARNINGS

Ensure that APU DC power supply is disconnected.

Ensure that the APU is turned off and completely de-energized before opening generator housing.

Failure to observe these warnings could result in severe injury or DEATH to personnel.

- a. Tag and disconnect connectors J4 (12, Figure 4-36), J5 (10), and J6 (9).
- b. Tag and remove electrical leads (6 and 7) between governor control assembly and actuator/solenoid.
- c. Remove four screws (17) (bolts, SICPS), and remove generator housing top cover (18).

CAUTION

Note position of items (1) and (2) during disassembly to ensure proper reassembly.

NOTE

Bolt on governor control unit securing the governor control unit ground wire also secures ground wires inside the generator top that must be removed prior to removing governor control unit.

- d. Inside generator top, remove nut with captive washer (1), two ground leads (2), one more nut with captive washer (1), and two more ground leads (2) from bolt (5).
- e. Remove ground leads (2).
- f. Outside generator top, remove bolt (5) and lock washer (3) securing governor control assembly ground wire (4). Remove ground wire (4).
- g. Remove three remaining bolts and nuts with captive washers (14) securing governor control assembly (16) to generator back panel (15) and remove governor control assembly (16).
- h. Install new governor control assembly (16) to generator back panel (15) and secure with three bolts and nuts with captive washers (14) in upper left, bottom left, and bottom right mounting holes.
- i. Install governor control ground wire (4) to upper right mounting hole, and secure with remaining bolt (5) and nut with captive washer (3).
- j. Inside generator top, install two ground wires (2) to bolt (5), nut with captive washer (1), two more ground wires (2), and one more nut with captive washer (1).
- k. Re-connect electrical leads (6 and 7) between governor control assembly (16) and actuator/solenoid.
- l. Re-connect connectors J4 (12), J5 (10), and J6 (9).
- m. Install cover to generator housing top cover (18) and secure with four screws (17) bolts.

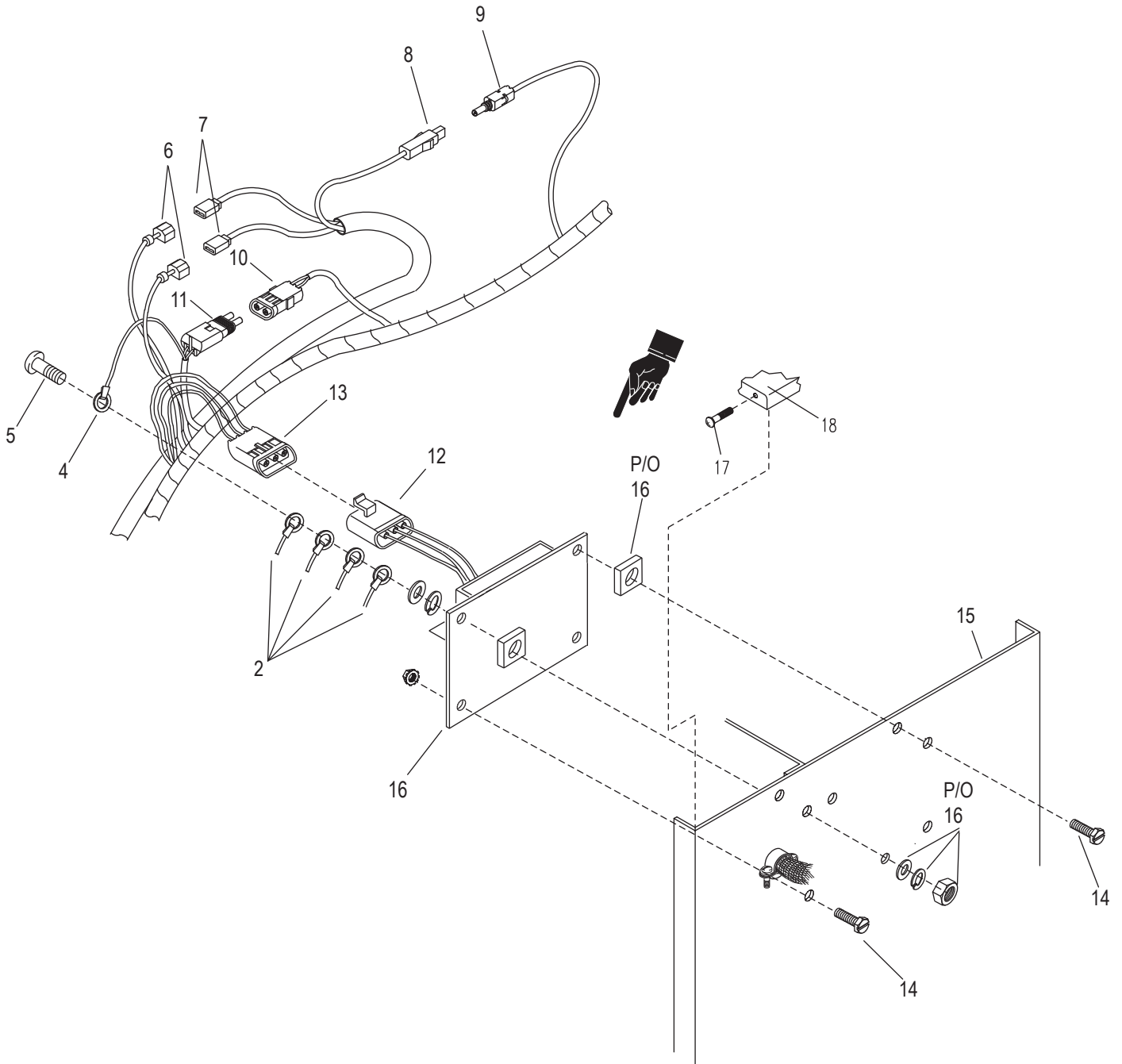

Figure 4-36. Governor Control Assembly

4.49. ACTUATOR SOLENOID₂

This task covers: a. Test b. Replace

INITIAL SETUP

Tools

General Mechanic's Tool Kit
(Item 1, Appendix B)

Battery, 24 Volt
(Item 20, Appendix B)

Equipment Conditions

MASTER ON-OFF switch on APU control unit
set to OFF.

Materials/Parts

Actuator/Solenoid

TEST

- a. Tag and remove electrical leads from actuator/solenoid leads (2, Figure 4-37).
- b. Connect 24-volt battery (1) to actuator/solenoid leads (2).
- c. Observe actuator shaft. Shaft should push out 0.775 in. to 0.825 in. (1.969 to 2.096 cm).
- d. Remove power. Actuator shaft should return to normal position.
- e. If actuator/solenoid does not operate, replace actuator/solenoid.

REPLACE

- a. Tag and remove actuator solenoid electrical leads (2) from governor electrical leads.
- b. Remove screw (11), lock washer (9), and nut (8) which secures rod end bearing (5) and clevis (10).
- c. Separate rod end bearing (5) from clevis (10).
- d. Remove clevis (10) from actuator shaft (3).
- e. Remove hex stop nut (12) from actuator shaft (3).
- f. Remove four bolts (4), washers (7), and nuts (6) securing actuator/solenoid (13) to mounting bracket and remove actuator/solenoid (13).
- g. Place new actuator/solenoid (13) on mounting bracket and secure with four bolts (4), washers (7), and nuts (6).
- h. Install stop nut (12) onto actuator shaft (3) and screw on until nut (12) is completely seated into threads on shaft (3).

- i. Install clevis (10) and turn until clevis (10) is up against stop nut (12).

NOTE

Ensure that stop nut and clevis are completely threaded on shaft. No threads should be visible.

- j. Align hole in rod end bearing (5) with hole in clevis (10) and install socket head screw (11), lock washer (9), and nut (8).
- k. Reconnect actuator/solenoid leads (2) with electrical leads. Remove tags.
- l. Adjust actuator linkage (para 4.50.).

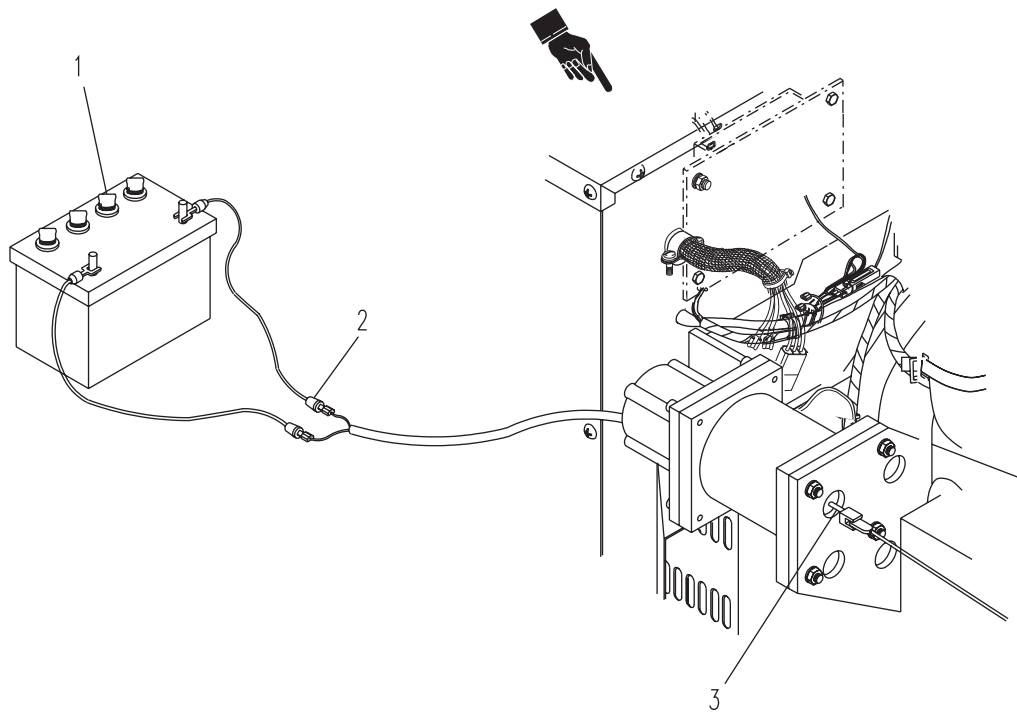

Figure 4-37. Actuator/Solenoid (Sheet 1 of 2)

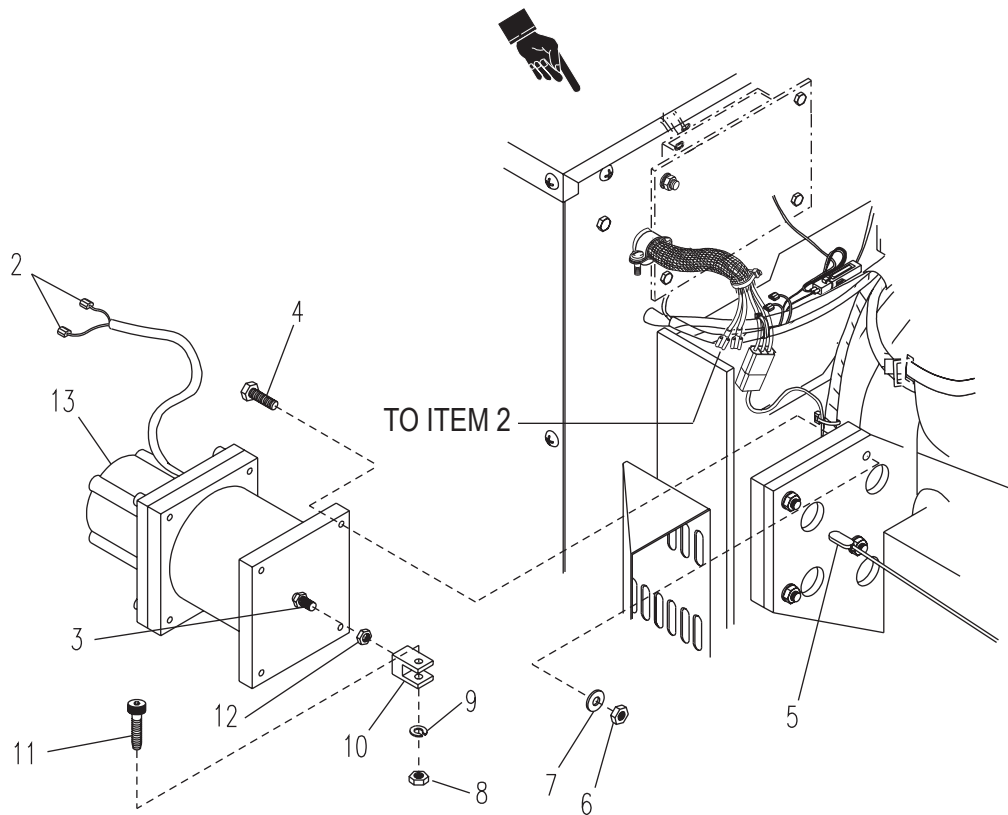

Figure 4-37. Actuator/Solenoid (Sheet 2)

4.50. ACTUATOR LINKAGE.

This task covers: a. Service b. Adjust c. Replace

INITIAL SETUP

ToolsGeneral Mechanic's Tool Kit
(Item 1, Appendix B)Equipment ConditionsMASTER ON-OFF switch on APU control unit
set to OFF.Materials/Parts

Fan guard removed (para 4.18.).

Actuator Linkage

SERVICE

Clean and lubricate governor linkage and rod ends.

ADJUST

- a. Ensure stop nut (1, Figure 4-38) is against the bottom thread of actuator shaft (14).
- b. Remove socket head screw (4), lock washer (11), and nut (12) that secures rod end bearing (13) of long actuator linkage rod (3) to pivot arm (10).
- c. Separate rod end bearing (13), from pivot arm (10).
- d. Adjust distance between pins in long actuator linkage rod (3) to obtain length of 6-11/16 in. (16.98 cm) by turning rod end bearing (13).
- e. Ensure clevis (2) is bottomed out against stop nut (1).
- f. Align hole in rod end bearing (13) with hole in pivot arm (10) and install lock washer (11), nut (12), and socket head screw (4). Ensure hex head screws on each end of long actuator rod are parallel.

NOTE

Ensure that no thread on the actuator shaft is showing.

- g. Remove socket head screw (5), star lock washer (8), and nut (9) securing rod end bearing (7) of short actuator linkage rod (6) to pivot arm (10).
- h. Adjust distance between pins in actuator linkage rod (6) to obtain a length of 2-3/8 in. (6.08 cm).
- i. Secure rod end bearing (7) of short linkage rod (6) to pivot arm (10) with socket head screw (5), star lock washer (8), and nut (9).

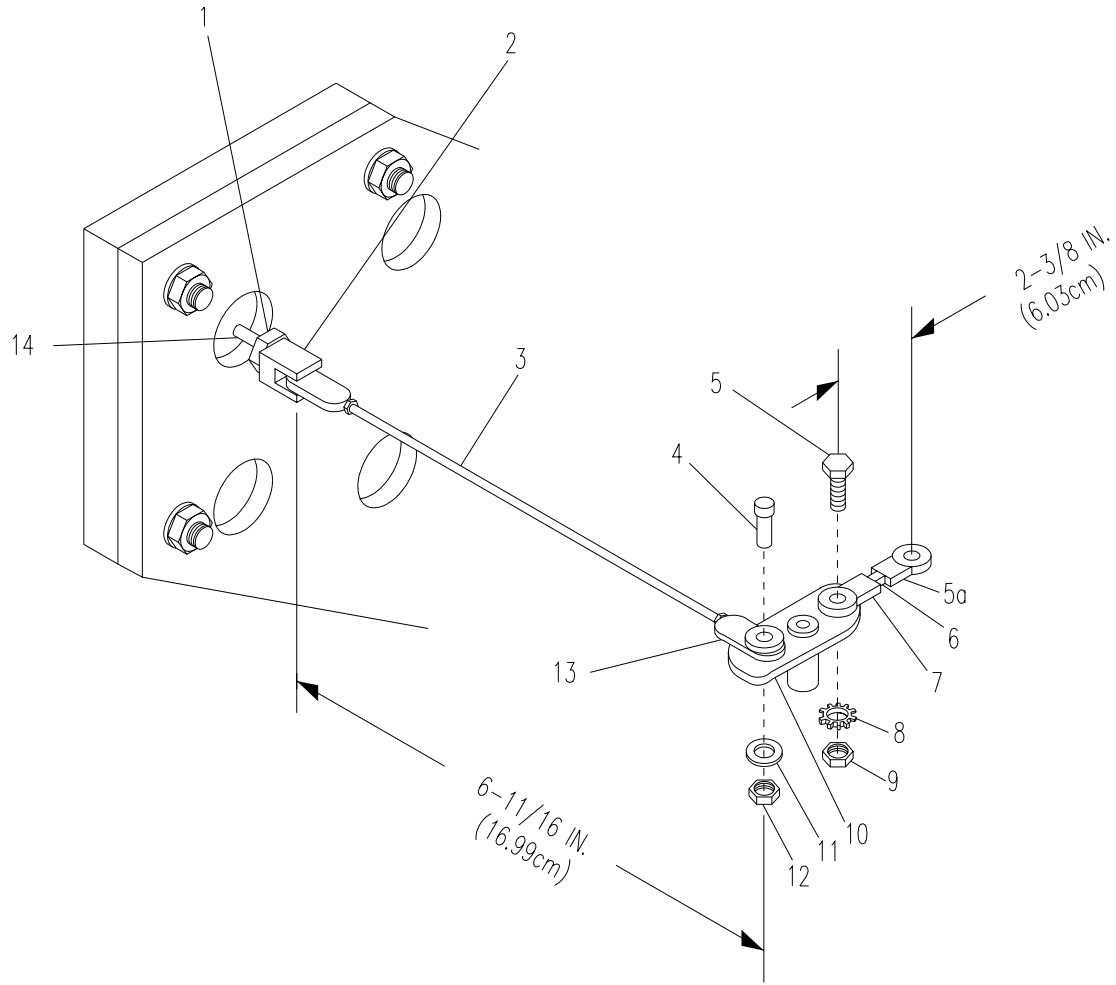

Figure 4-38. Actuator Linkage (Sheet 1 of 2)

REPLACE

- a. Remove one socket head screw (15), nut (24), and lock washer (25) securing rod end bearing (16) of long actuator linkage rod (3) to clevis (2) and remove rod end bearing (16).
- b. Remove one socket head screw (4), nut (12), and lock washer (11) securing rod end bearing (13) of long actuator linkage rod (3) to pivot arm (10) and remove rod end bearing (13).
- c. Remove one bolt (20), nut with captive washer (22) securing rod end bearing (5a) of short actuator linkage rod (6) to governor arm (21) and remove rod end bearing (5a).
- d. Remove one bolt (5), nut (9) and star lock washer (8) securing rod end bearing (7) of short actuator linkage rod (6) to pivot arm (10) and remove rod end bearing (7).
- e. Remove one shoulder bolt (19) securing pivot arm (10) to governor linkage pivot plate (23) and remove pivot arm (10).
- f. Unscrew and remove two rod end bearings (13 and 16) and two hex nuts (17 and 18) from long actuator linkage rod (3).
- g. Unscrew and remove two rod end bearings (5a and 7) from short actuator linkage rod (6).
- h. Unscrew and remove clevis (2) and stop nut (1) from actuator shaft (14).
- i. Install stop nut (1) fully onto actuator shaft (14).
- j. Install clevis (2) on actuator shaft (14) and turn until fully against stop nut (1).
- k. Install two rod end bearings (5a and 7) on short actuator linkage rod (6).
- l. Adjust distance between rod end bearings to obtain a length of 2 3/8 in. (6.08 cm).
- m. Install two hex nuts (17 and 18) and two rod end bearings (13 and 16) on long actuator linkage rod (6).
- n. Adjust distance between rod end bearings to obtain length of 6-11/16 in. (16.986 cm).
- o. Install pivot arm (10) on governor linkage plate (23) and secure with one shoulder bolt (19).
- p. Install rod end bearing (5a) of short actuator linkage rod (6) on governor arm (21) and secure with one bolt (20), and nut with captive washer (22).
- q. Install remaining rod end bearing (7) of short actuator linkage rod (6) on pivot arm (10) and secure with one bolt (5), nut (9) and star lock washer (8).
- r. Install rod end bearing (13) of long actuator linkage rod (3) on pivot arm (10) and secure with one socket head screw (4), lock washer (11) and nut (12).
- s. Install remaining rod end bearing (16) of long actuator linkage rod (3) on clevis (2) and secure with socket head screw (15), lock washer (25), and nut (24).

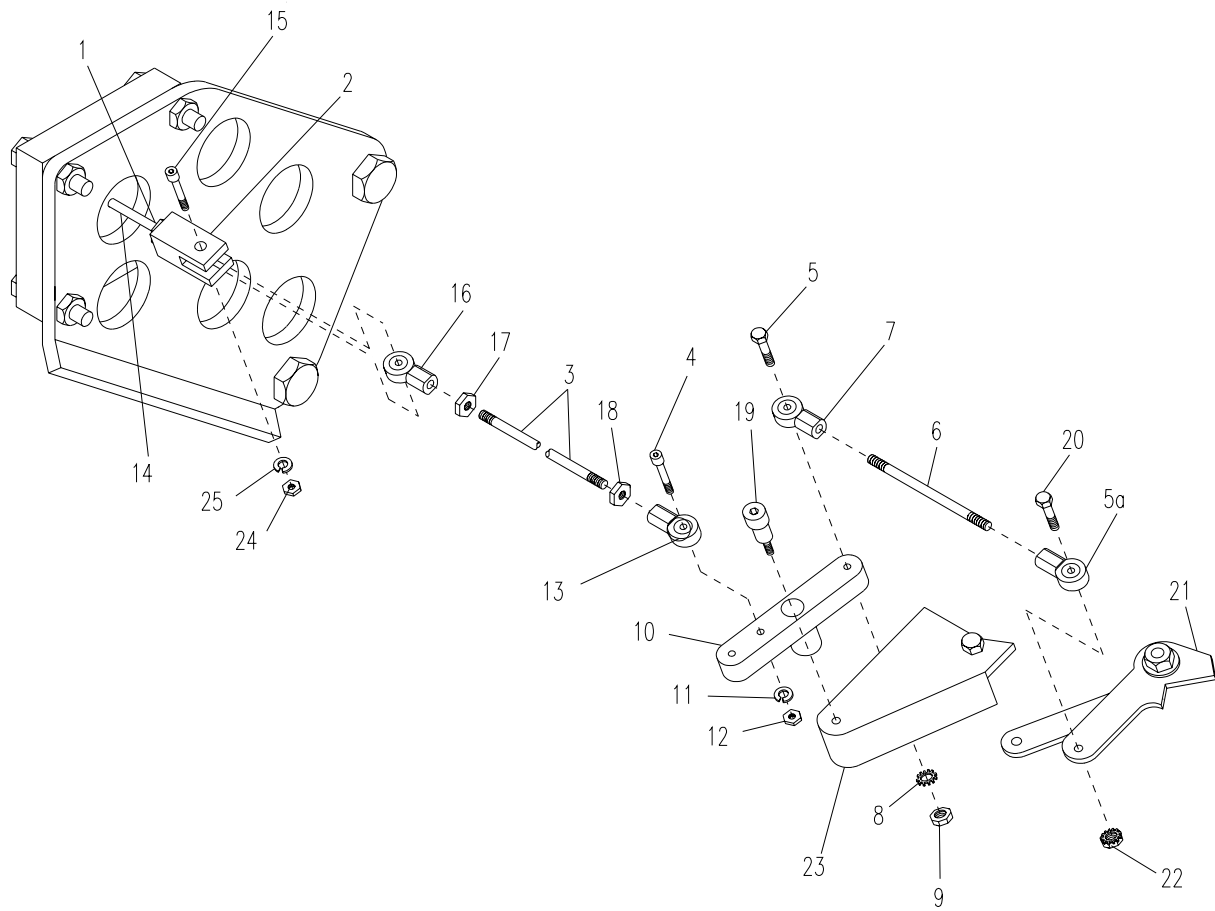

Figure 4-38. Actuator Linkage (Sheet 2)

4.51. ELECTRICAL OUTPUT TERMINAL BOARD

This task covers: Replace

INITIAL SETUP

Tools

General Mechanic's Tool Kit
(Item 1, Appendix B)

Materials/Parts

Electrical Output Terminal Board

Equipment Conditions

MASTER ON-OFF switch on APU control unit set to OFF.

Air filter removed (para 4.45.).

WARNING

Ensure that APU DC power supply is disconnected. Failure to observe this warning could result in severe injury or DEATH to personnel.

WARNING

Ensure that the APU is turned off and completely de-energized before opening generator housing. Failure to observe this warning could result in severe injury or DEATH to personnel.

REPLACE

- a. Remove four screws (JTACS), or slotted hex-head bolts (SICPS and WIN-T), flat and lock washers (15, Figure 4-39), and remove generator housing top cover (16).
- b. Remove four bolts (1) and lock washers (2) securing protective cover (25). Remove cover (25).
- c. Remove four bolts (5), star washers (4), and four separators (3).
- d. Remove four nuts (24), star washer (23), flat washers (22). Tag and remove shelter terminal leads (21) from terminal board (6).
- e. Remove two jumper bars (20) from terminal posts (8).
- f. Inside generator housing, remove four nuts (12), star washers (11), and flat washers (10) from terminal posts (8).
- g. Tag and remove electrical leads (9) from terminal posts (8).
- h. Remove eight nuts, four washers and four lock washers (7 and 19) and remove terminal posts (8).
- i. Remove seven screws from housing rear and remove housing (no identifying figure).
- j. Inside generator housing, at bottom of terminal board (6), remove two nuts with captive washers (14) from countersunk hex socket screws and remove terminal board (6).
- k. At top of terminal board (6), remove two bolts (18) and nuts with captive washers (13).
- l. Align holes in terminal board (6) and generator housing and secure terminal board with two bolts (18) and nuts with captive washers (13) through two holes at top of terminal board.

- m. Inside generator housing, at bottom of terminal board (6), install two nuts with captive washers (14) on two countersunk hex socket screws (17).
- n. Install four terminal posts (8) and secure with four washers and four lock washers (19 and 7).
- o. Inside generator housing, install electrical leads (9) to terminal posts (8) and secure with four flat washers (10), lock washers (11), and nuts (12). Remove tags.
- p. Install two jumper bars (20) on terminal posts.

NOTE

Refer to FO-1 or FO-7 for installation of jumper bars for low voltage (120 VAC) and/or high voltage (240 VAC) power connections.

- q. Outside generator housing, install terminal leads to appropriate terminal posts (8) and secure four flat washers (22), lock washers (23), and nuts (24).
- r. Install four separators (3) and secure with four bolts (5) and star washers (4).
- s. Install protective cover (25) and secure with four lock washers (2) and bolts (1).
- t. Install generator housing top cover (16) and secure with four screws (JTACS), or slotted hex-head bolts (SICPS and WIN-T), flat and lock washers (15).

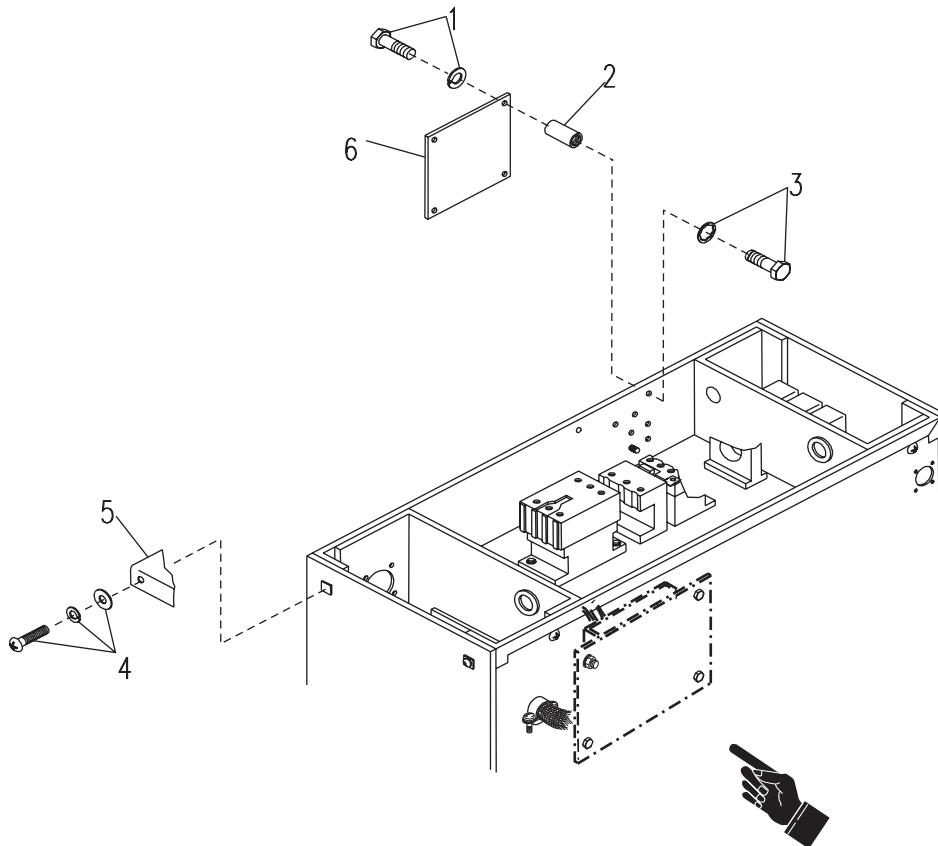

Figure 4-39. Electrical Output Terminal Board

4.52. CONTACTOR MOUNTING PLATE.

This task covers: a. Remove b. Install

INITIAL SETUP

Tools

General Mechanic's Tool Kit
(Item 1, Appendix B)

Equipment Conditions

MASTER ON-OFF switch on APU control unit set to OFF.

Materials/Parts

Contactor Mounting Plate

Strap, Tie down, Elect
(Item 22, Appendix F)

WARNING

Ensure that APU DC power supply is disconnected.
Failure to observe this warning could result in severe injury or DEATH to personnel.

WARNING

Ensure that the APU is turned off and completely de-energized before opening generator housing.
Failure to observe this warning could result in severe injury or DEATH to personnel.

REMOVE

CAUTION

Take care not to cut wires or other APU components when removing tiedown straps.

- a. Refer to Figure FO-1 (SICPS/WIN-T) or F0-7 (JTACS) and move electrical leads from main AC contactor.
 - (1) Tag and remove leads from contactor terminals L1, L2, and L3 by loosening three dual purpose screws.
 - (2) Tag and remove leads from contactor terminals A1 and A2 by loosening two dual purpose screws.
- b. Refer to Figure FO-1 (SICPS/WIN-T) or F0-7 (JTACS) and move electrical leads from overload relay.
 - (1) Tag and remove leads from overload relay terminals T1, T2, and T3 by loosening three dual purpose screws.
 - (2) Tag and remove electrical leads from NC95 and NC96.
- c. Refer to Figure FO-1 (SICPS/WIN-T) or F0-7 (JTACS) and move electrical leads from current transformer.

CAUTION

When reinstalling contactor plate, wire must be wrapped the same number of turns around current transformer as it was before removal.

- (1) Follow wire from terminal T1 to where it is wrapped around current transformer and cut tie down strap.
 - (2) Tag and remove lead from terminal T1 by loosening one all purpose screw.
 - (3) Cut and remove tie down strap securing wire connected to terminal A.
 - (4) Tag and remove leads from terminals A and B by loosening two nuts and lock washers.
 - (5) Unwrap and remove all wires from current transformer (refer to caution above).
- d. Remove contactor mounting plate (2, Figure 4-40) by removing four nuts with captive washers (1) from vibration studs (3).

INSTALL

- a. Install contactor mounting plate (2) on vibration studs (3) and secure with four nuts with captive washers.
- b. Refer to Figure FO-1 (SICPS/WIN-T) or F0-7 (JTACS) and connect electrical leads to current transformer.
 - (1) Connect lead to terminal B and secure with one screw.
 - (2) Wrap wire with lead to be connected to terminal A through hole and over the top of current transformer the same number of turns and secure with tiedown strap (refer to caution above).
 - (3) Install lead to terminal A and secure with one nut and lock washer.
- c. Refer to Figure FO-1 (SICPS/WIN-T) or F0-7 (JTACS) connect electrical leads to overload relay.
 - (1) Connect leads of wires from L2 and L3 of electrical output terminal board to terminals T2 and T3 on overload relay, respectively, and secure with two screws.
 - (2) Wrap wire from terminal L1 of electrical output terminal board through hole and over the top of current transformer the same number of turns and secure with one tiedown strap (refer to caution above).
 - (3) Connect lead to terminal T1 and secure with one screw.
- d. Refer to Figure FO-1 (SICPS/WIN-T) or F0-7 (JTACS) connect electrical leads to main AC contactor.
 - (1) Connect leads to terminals L1, L2, and L3 and secure with three screws.
 - (2) Connect leads to terminals A1 and A2 and secure with two screws.

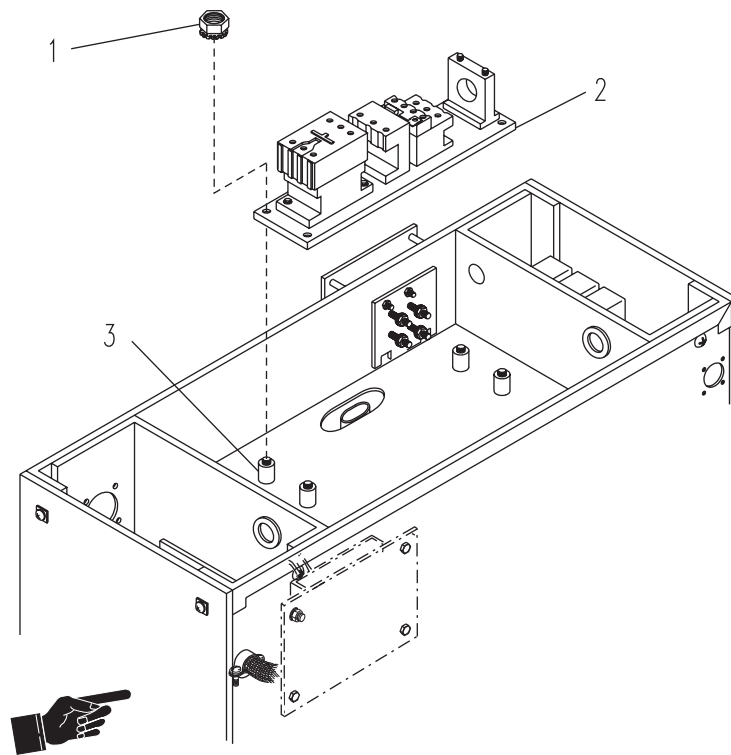

Figure 4-40. Contactor Mounting Plate

4.53. MAIN AC CONTACTOR.

This task covers: a. Test b. Replace

INITIAL SETUP

Tools

General Mechanic's Tool Kit
(Item 1, Appendix B)

Shop Equipment, Electrical Repair,
Semi-trailer Mounted
(Item 3, Appendix B)

Materials/Parts

Main AC Contactor

Reference: Figure FO-1

Equipment Conditions

MASTER ON-OFF switch on APU control unit set to OFF.

Contactor mounting plate removed (para 4.52.).

WARNING

Ensure that APU DC power supply is disconnected. Failure to observe this warning could result in severe injury or DEATH to personnel.

WARNING

Ensure that the APU is turned off and completely de-energized before opening generator housing. Failure to observe this warning could result in severe injury or DEATH to personnel.

TEST

- a. Refer to Figure FO-1 (SICPS/WIN-T) or F0-7 (JTACS) and tag and disconnect electrical leads from terminals T1, T2, and T3 on main AC contactor by loosening three screws.
- b. Using a Multi-meter, test for continuity between terminals L1 and T1 on main AC contactor. There should be no continuity.
- c. Refer to Figure 4-41, sheet 1, and apply 24 VDC across main AC contactor (1) terminals A1 and A2 by connecting positive lead from a power supply to terminal A1 and negative lead from power supply (5) to terminal A2.
- d. Repeat step b. There should be continuity.
- e. Remove 24 VDC. Continuity between L1 and T1 should be broken.
- f. Perform steps b through e, testing continuity between L2 and T2 and L3 and T3 on main AC contactor (1).
- g. If any pair of contacts fails the continuity test, the main AC contactor is defective. Replace main AC contactor.

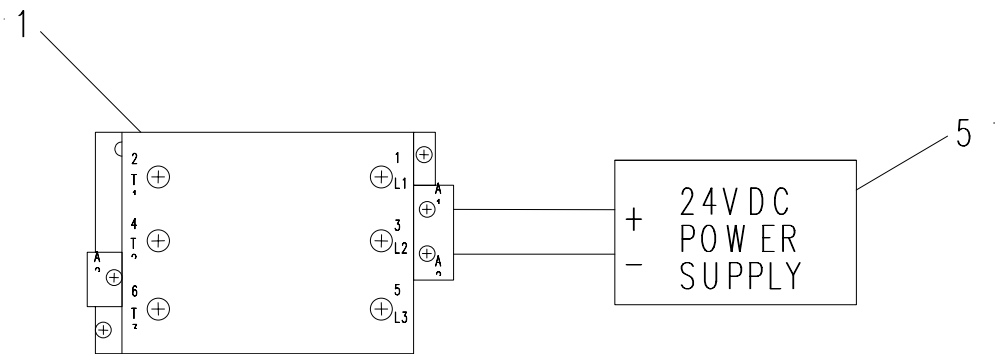

Figure 4-41. Main AC Contactor (Sheet 1 of 2)

REPLACE

WARNING

Ensure that APU DC power supply is disconnected. Failure to observe this warning could result in severe injury or DEATH to personnel.

WARNING

Ensure that the APU is turned off and completely de-energized before opening generator housing. Failure to observe this warning could result in severe injury or DEATH to personnel.

- a. Refer to Figure FO-1 (SICPS/WIN-T) or F0-7 (JTACS) and tag and disconnect electrical leads from terminals T1, T2, and T3 of main AC contactor (1) by loosening three screws.
- b. Remove diode (number to be determined) from Terminals A1 and A2.

NOTE

Observe polarity of the diode.

- c. Reinstall diode (number to be determined) to Terminals A1 and A2 on main AC contactor, observing the same polarity.
- d. Remove main AC contactor (1) from contactor mounting plate (3) by removing two screws (4) and two nut and captive washer assemblies (2).
- e. Secure main AC contactor (1) to contactor mounting plate (3) by securing with two screws (4) and two nuts and captive washer assemblies (2).
- f. Refer to Figure FO-1 (SICPS/WIN-T) or F0-7 (JTACS) and connect electrical leads to terminals T1, T2, and T3 of main AC contactor (1) and secure by tightening three screws.

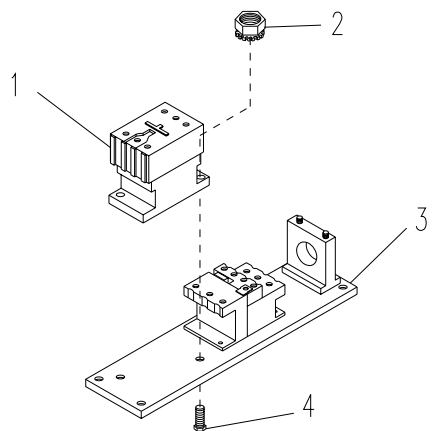

Figure 4-41. Main AC Contactor (Sheet 2)

4.54. GROUND STRAP.

This task covers: Replace

INITIAL SETUP

Tools

General Mechanic's Tool Kit
(Item 1, Appendix B)

Materials/Parts

Ground Strap

Equipment Conditions

MASTER ON-OFF switch on APU control unit set to OFF.

WARNING

Ensure that APU DC power supply is disconnected. Failure to observe this warning could result in severe injury or DEATH to personnel.

WARNING

Ensure that the APU is turned off and completely de-energized before opening generator housing. Failure to observe this warning could result in severe injury or DEATH to personnel.

REPLACE

- a. Remove four screws (JTACS) (2, Figure 4-42) or four slotted hex-head bolts (SICPS and WIN-T), flat and lock washers securing generator housing top cover (1).
- b. Remove two screws, two wing nuts and lock washers (4a) (JTACS), or four slotted hex-head bolts (SICPS and WIN-T), flat and lock washers (4), and generator housing side cover (3) (muffler side).
- c. Remove one bolt and flat and lock washer (8) and ground strap (7).
- d. Remove one screw and flat washer (5), two nuts and lock washers (6), and ground strap (7) from frame assembly (9).
- e. Install ground strap (7) on frame assembly (9) and secure with one screw and flat washer (5) and two nuts and lock washers (6).
- f. Install ground strap (7) to generator and secure with one bolt and flat and lock washer (8).
- g. Install generator housing side cover (3) and secure with two screws and two wing nuts and lock washers (4a) (JTACS), or four slotted hex-head bolts (SICPS and WIN-T), flat and lock washers (4).
- h. Install generator housing top cover (1) and secure with four screws (JTACS) or four slotted hex-head bolts (SICPS and WIN-T), flat and lock washers (2).

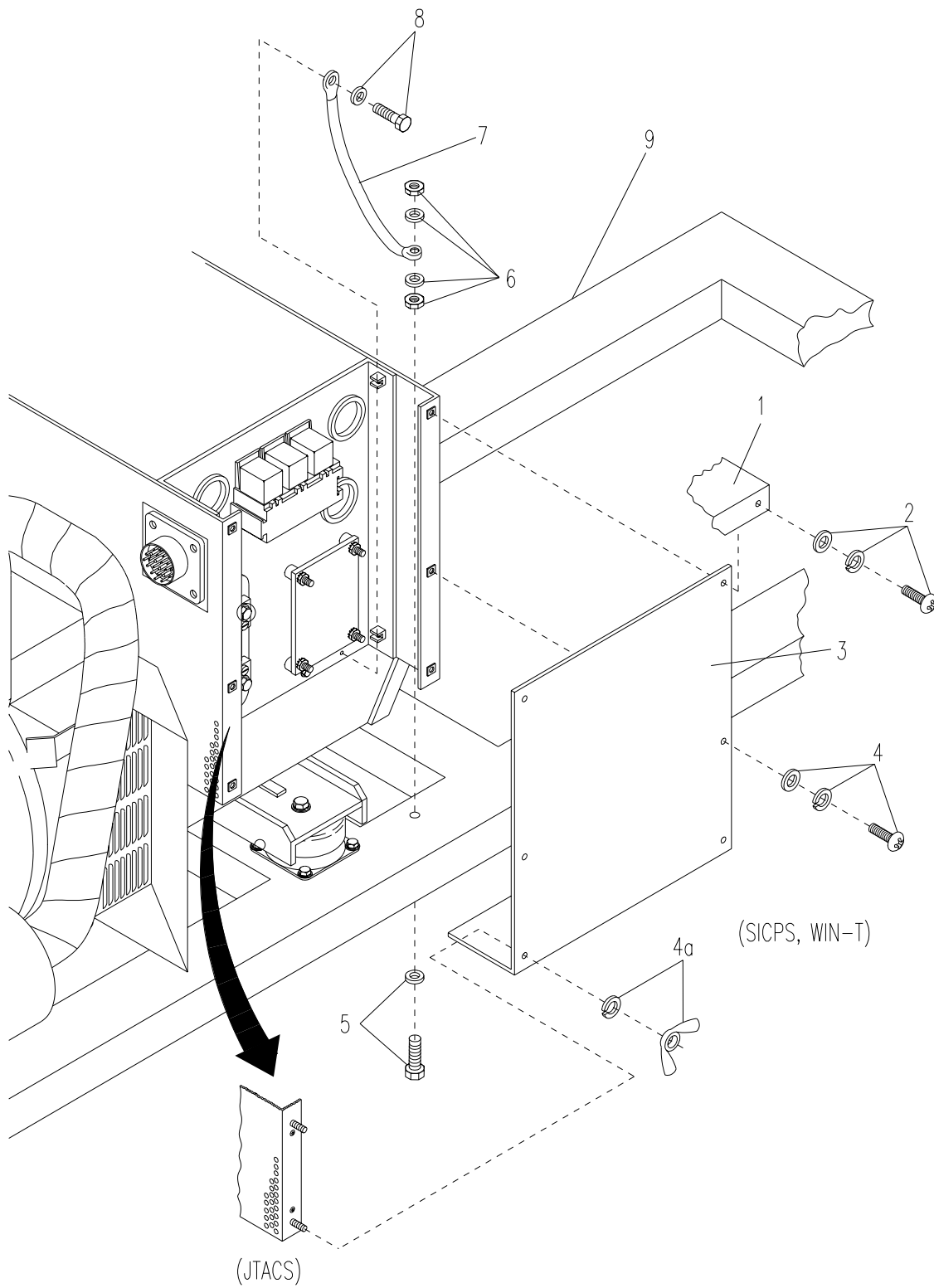

Figure 4-42. Ground Strap

4.55. CURRENT SHUNT.

This task covers: a. Inspect b. Replace

INITIAL SETUP

Tools

General Mechanic's Tool Kit
(Item 1, Appendix B)

Multi-meter

Materials/Parts

Current Shunt

Equipment Conditions

MASTER ON-OFF switch on APU control unit set to OFF.

Air filter removed (para 4.45.).

WARNING

Ensure that APU DC power supply is disconnected. Failure to observe this warning could result in severe injury or DEATH to personnel.

WARNING

Ensure that the APU is turned off and completely de-energized before opening generator housing. Failure to observe this warning could result in severe injury or DEATH to personnel.

INSPECT

- a. Visually inspect shunt for signs of burns, corrosion, breakage or short out. Replace shunt if defective.
- b. Check for loose connections. Tighten any loose connections.
- c. Test for continuity.

REPLACE

- a. Remove four screws (JTACS), or slotted hex-head bolts (SICPS and WIN-T), flat and lock washers (2, Figure 4-43), and generator housing top cover (1).
- b. Remove two screws, two wing nuts and lock washers (4a) (JTACS), or four slotted hex-head bolts (SICPS and WIN-T), flat washers and lock washers (4) and generator housing side cover (3).
- c. Remove two machine screws, lock washers and flat washers (7) from shunt (6). Tag and remove electrical leads (6a) from shunt.
- d. Remove two hex-head bolts and flat washers (8) from shunt (6). Tag and remove electrical leads (8a) from shunt.
- e. Remove two bolts, lock washers, and flat washers (5, Figure 4-5) from generator bracket (6) and air deflector (4). Remove air deflector.

- f. Remove cannon plug (P1 from J1).
- g. Remove four screws (JTACS), slotted hex bolts, and lock washers (SICPS and WIN-T) (5, Figure 5-17) securing regulator box (2) to generator housing (11).
- h. Remove three bolts and lock washers (4) and regulator box (2).
- i. Remove two captive screws (1) and flat washers from regulator box (2).
- j. Maneuver regulator box to access machine screws (9, Figure 4-43) and nuts with captive washers (5) securing shunt (6) to box. Remove machine screws (9) and nuts with captive washers (5) and current shunt (6).

NOTE

Restrain nut from spinning with number 2, 3/16-in. flat-tipped screwdriver.

- k. Install current shunt (6), two machine screws (9), and nuts with captive washers (5).
- l. Install two captive screws (1, Figure 5-17) and flat washers to regulator box.
- m. Install three bolts and lock washers (4) and regulator box (2).
- n. Install four screws (JTACS), slotted hex bolts, and lock washers (5) (SICPS and WIN-T) securing regulator box (2) to generator housing (11).
- o. Connect cannon plug (P1 to J1).
- p. Install two bolts, lock washers and flat washers (5, Figure 4-5) to generator bracket (6) and air deflector (4).
- q. Install electrical leads (8a, Figure 4-43) to shunt and secure with two hex-head bolts and flat washers (8).
- r. Install electrical leads (6a) to shunt and secure with two machine screws (7).
- s. Install two screws, two wing nuts and lock washers (4a) (JTACS), or four slotted hex-head bolts (SICPS and WIN-T), flat and lock washers (4), and generator housing side cover (3).
- t. Install generator housing top cover (1) and secure with four screws (JTACS), or slotted hex-head bolts (SICPS and WIN-T), flat and lock washers (2).

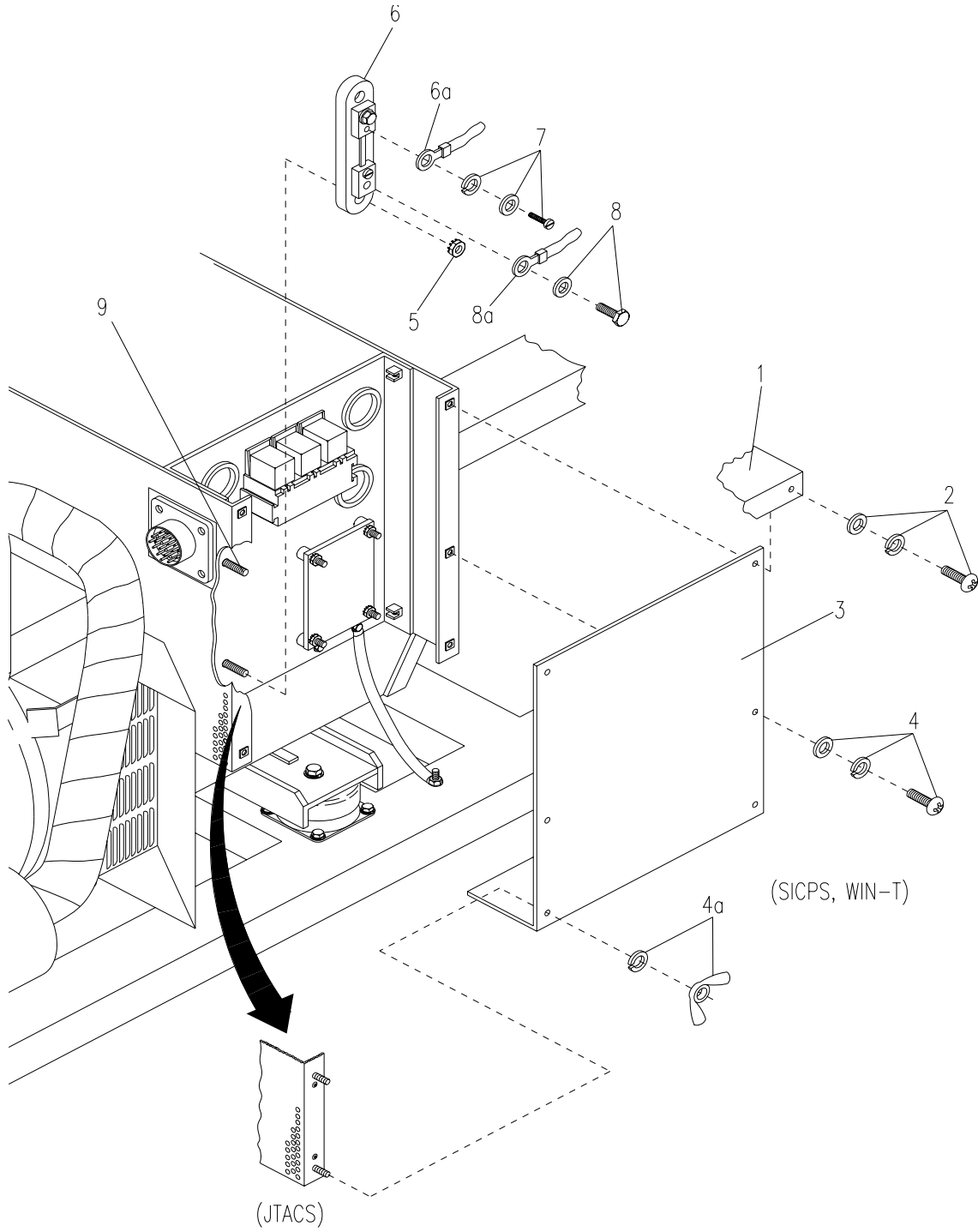

Figure 4-43. Current Shunt

4.56. SPEED SENSOR.

This task covers: a. Test b. Adjust c. Replace

INITIAL SETUP

Tools

General Mechanic's Tool Kit
(Item 1, Appendix B)

Multimeter

Materials/Parts

Speed Sensor

Field Gauge

Strap, Tiedown, Elect.
(Item 22, Appendix F)

Equipment Conditions

MASTER ON-OFF switch on APU control unit
set to OFF.

MASTER ON-OFF switch on APU controller set to
OFF.

Radiator overflow tank, removed (para 4.28., steps a-
c).

Air deflector removed (para 4.18., step b).

TEST

- a. Remove connector J6 (7) from governor speed control (8).
- b. Measure resistance of speed sensor. Resistance should be 750 ohms +/- 250 ohms.
- c. Replace if defective.

ADJUST

- a. Remove connector J6 (7) from the governor speed control (8).

CAUTION

Take care not to cut wires or other APU
components when removing wire ties.

- b. Cut and remove tiedown straps as necessary to remove speed sensor wire (6).
- c. Remove sensor (7) and sensor securing nut (1); remove sensor (3) from engine bell housing (5).
- d. Observe that flywheel gear tooth (4) is aligned with access hole (2) in engine bell housing from which speed sensor (3) was removed.
- e. Install sensor (3) into engine bell housing (5) and ensure that sensor is aligned and makes contact with crest of engine flywheel gear tooth (4).
- f. Turn speed sensor ccw one and a half turns, backing it out.

NOTE

Distance between speed sensor end and flywheel teeth should be 0.0150 inches.

- g. Measure resistance of speed sensor. Resistance should be 750 ohms +/- 250 ohms.
- h. At J6 connector, measure voltage while cranking engine. Voltage should read between 8 V and 18 V (0.010 inch (0.254 mm) and 0.030 inch (0.762 mm) tolerance range). If voltage does not read between 8 V and 18 V, adjust speed sensor as necessary.
- i. Secure sensor (3) with sensor securing nut (1).
- j. Replace connector J6 (7) to governor speed control (8).
- k. Install air deflector (para 4.18.).

REPLACE

- a. Remove connector J6 (7) from governor speed control (8).

CAUTION

Take care not to cut wires or other APU components when removing wire ties.

- b. Cut and remove tiedown straps as necessary to remove speed sensor wire (6).
- c. Remove sensor (3) securing nut (1) and remove sensor (3) from engine bell housing (5).
- d. Screw sensor (3) into engine bell housing (5) making sure that sensor (3) is aligned with crest of engine flywheel gear tooth (4).
- e. Adjust sensor.
- f. Secure sensor (3) with sensor securing nut (1).
- g. Secure sensor wire (6) with tiedown straps.
- h. Install air deflector (para 4.18.).

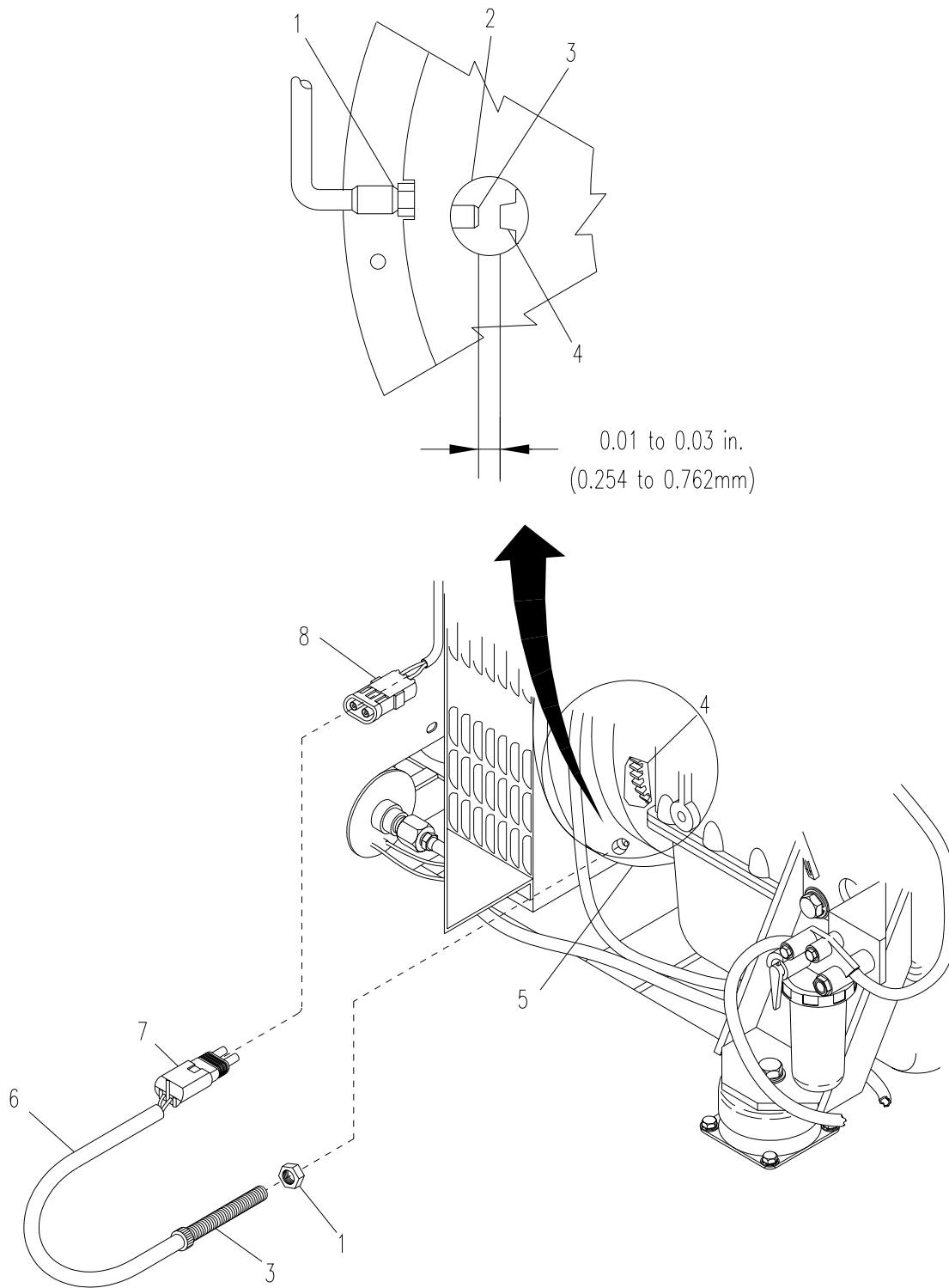

Figure 4-44. Speed Sensor

4.57. ELECTRICAL METERS.

This task covers: a. Test b. Replace

INITIAL SETUP

Tools

General Mechanic's Tool Kit
(Item 1, Appendix B)

Multi-meter

Materials/Parts

AC VOLT Meter
AC AMP Meter
HERTZ Meter
DC AMP Meter

Equipment Conditions

APU control unit disconnected from shelter
(refer to system TM).

TEST

AC VOLTAGE METER

- a. Refer to FO-1 (SICPS/WIN-T), or FO-7 (JTACS), and disconnect plug J2 from P2.
- b. Remove electrical leads from meter by performing steps "a.", "b.", and "c." of REPLACE procedure.
- c. Measure resistance on terminals at rear of meter. Resistance reading should be 69.0 ohms +/- 5 ohms.
- d. If meter reading is not within the specified resistance, replace meter.

AC AMPERES METER (MOTOR LOAD CURRENT)

- a. Refer to FO-1 (SICPS/WIN-T), or FO-7 (JTACS), and disconnect plug J2 from P2.
- b. Remove electrical leads from meter by performing steps "a.", "b.", and "c." of REPLACE procedure.
- c. Measure resistance on terminals at rear of meter. Resistance reading should be 0.1 ohms.
- d. If meter reading is not within the specified resistance, replace meter.

HERTZ METER

- a. Refer to FO-1 (SICPS/WIN-T), or FO-7 (JTACS), and disconnect plug J2 from P2.
- b. Remove electrical leads from meter by performing steps "a.", "b.", and "c." of REPLACE procedure.
- c. Measure resistance on terminals at rear of meter. Resistance reading should be 7.0 ohms +/- 1.0 ohms.
- d. If meter reading is not within the specified resistance, replace meter.

DC AMPERES METER

- a. Refer to FO-1 (SICPS/WIN-T), or FO-7 (JTACS), and disconnect plug J2 from P2.
- b. Remove electrical leads from meter by performing steps "a.", "b.", and "c." of REPLACE procedure.
- c. Measure resistance on terminals at rear of meter. Resistance reading should be 50.0 ohms +/- 3 ohms.
- d. If meter reading is not within the specified resistance, replace meter.

REPLACE

NOTE

Use this procedure to replace A-C VOLT, A-C AMP, HERTZ, and D-C AMP meters. Refer to FO-1 (SICPS/WIN-T) or FO-7 (JTACS) when replacing electrical meters.

- a. Remove ten screws (caged nuts (SICPS), machine screws (JTACS and WIN-T)) (1, Figure 4-45) securing APU control unit cover to chassis and remove.
- b. At rear of meter (2), identify and tag terminal leads (6).

NOTE

Water temperature meter and hour meter have terminals.

- c. For each terminal lead, remove nut, flat washer, and lock washer (5) from terminal (7). Remove terminal leads (6).

- d. Remove three nuts and lock washers (4) and meter (2).
- e. Position new meter (2) in mounting holes on APU control unit front panel (3) and secure with three nuts and lock washers (4).
- f. Secure terminal leads (6) to terminals (7) with nuts, and flat washers, and lock washers (5) at rear of meter. Remove tags.
- g. Secure cover to chassis with ten screws (caged nuts (SICPS), machine screws (JTACS and WIN-T)) (1).
- h. Install APU control box unit (see system TM).

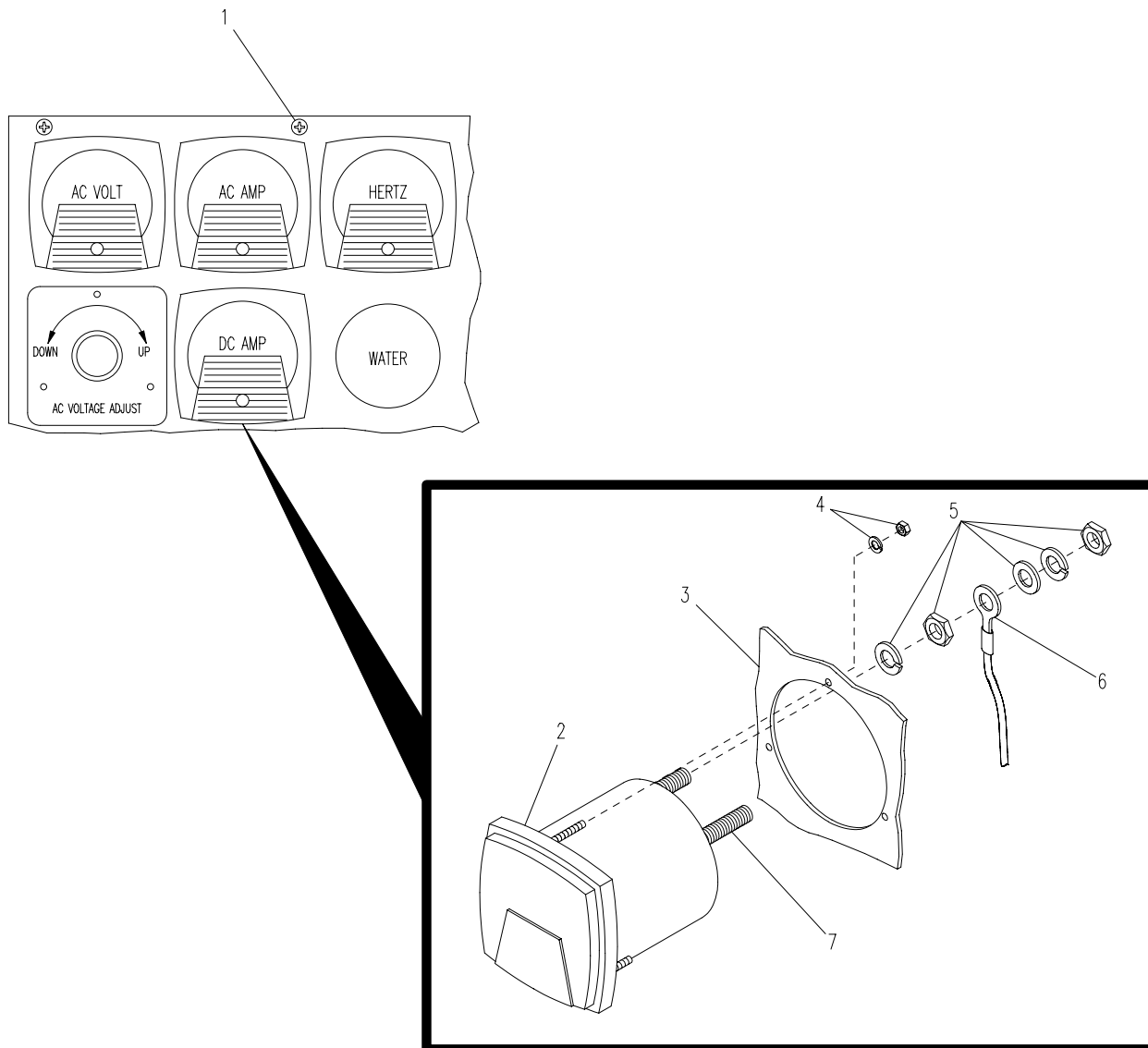

Figure 4-45. Electrical Meters

4.58. HOUR METER.

This task covers: Replace

INITIAL SETUP

Tools

General Mechanic's Tool Kit
(Item 1, Appendix B)

Materials/Parts

Hour Meter

Equipment Conditions

APU control unit disconnected from shelter.

Refer to system TM.

REPLACE

- a. Remove ten screws (caged nuts (SICPS), machine screws (JTACS and WIN-T)) (1, Figure 4-46) securing APU control unit cover to chassis and remove cover.
- b. At rear of meter (2), identify and tag terminal leads (3).
- c. Disconnect terminal leads (3) from terminals (4) by gently pulling apart.
- d. Remove two screws and nuts (two screws, lock washers and nuts (JTACS and WIN-T)) (two screws, lock washers and nuts (SICPS)) (5) securing hour meter (6) to APU control unit front panel.
- e. Carefully pull meter (6) through front of APU control front panel.
- f. Position meter (6) in APU control unit front panel (7) mounting hole.
- g. Secure meter (6) to APU control unit front panel (7) with two screws and nuts (5).
- h. Secure terminal leads (3) on terminals (4) and remove tags.
- i. Secure APU control unit cover to chassis with ten screws (caged nuts (SICPS), machine screws (JTACS and WIN-T)) (1).
- j. Install APU control unit (see system TM).

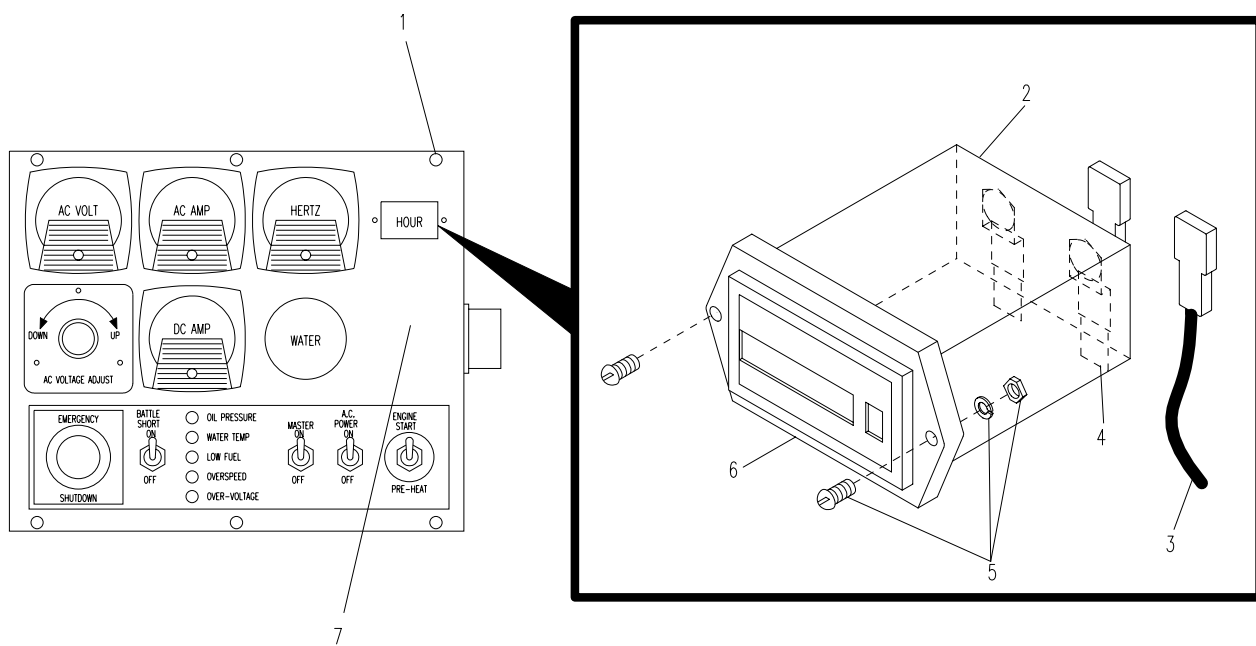

Figure 4-46. Hour Meter

4.59. AC VOLTAGE ADJUST POTENTIOMETER.

This task covers: a. Test b. Replace

INITIAL SETUP

Tools

General Mechanic's Tool Kit
(Item 1, Appendix B)

Shop Equipment, Electrical, Repair,
Semitrailer Mounted
(Item 3, Appendix B)

Multi-meter

Materials/Parts

Ac Voltage Adjust Potentiometer

Equipment Conditions

APU control unit disconnected from shelter.

TEST

- a. Disconnect Plug J2 from P2.
- b. Connect Multi-meter between terminals 1 and 3. Resistance should be 1000 ohms +/- 50 ohms.
- c. Connect Multi-meter between terminals 2 and 3. Turn Potentiometer shaft. Resistance should vary between 0 and 1000 ohms.
- d. Replace Potentiometer if defective.

REPLACE

- a. Remove ten screws (caged nuts (SICPS), machine screws (JTACS and WIN-T)) (1, Figure 4-47) securing APU control unit cover to chassis and remove cover.

NOTE

Display plate on JTACS and WIN-T only. JTACS and WIN-T unsolder, SICPS remove shrink wrap and unsolder.

- b. On potentiometer (5), identify and tag terminal leads (4).
- c. Carefully cut away insulation sleeving and expose soldered connections.
- d. Unsolder terminal leads (4).
- e. Loosen two hex-head screws (2) and remove potentiometer knob (6).

ARMY TM 9-6115-670-14&P

- f. Remove nut and lock washer (SICPS), nut only (JTACS and WIN-T) (3), and remove potentiometer (5).
- g. Install new potentiometer (5) in mounting hole and secure to panel with nut and lock washer (SICPS), nut only (JTACS and WIN-T) (3).
- h. Secure knob (6) onto potentiometer (5) with two hex-head screws (2).
- i. At the rear of potentiometer (5), identify terminal leads (4).
- j. Place insulation sleeving over terminal lead (4) and away from area to be soldered.
- k. Solder terminal leads (4) to appropriate terminals. Remove tags from terminal leads.
- l. Slide insulation sleeving over soldered connection. Use heat gun set on heat mode to shrink sleeving and secure soldered connection.
- m. Use heat gun set on cool mode to cool soldered connection and sleeving.
- n. Secure cover to chassis with ten screws (caged nuts (SICPS), machine screws (JTACS and WIN-T)) (1).
- o. Install APU control unit.

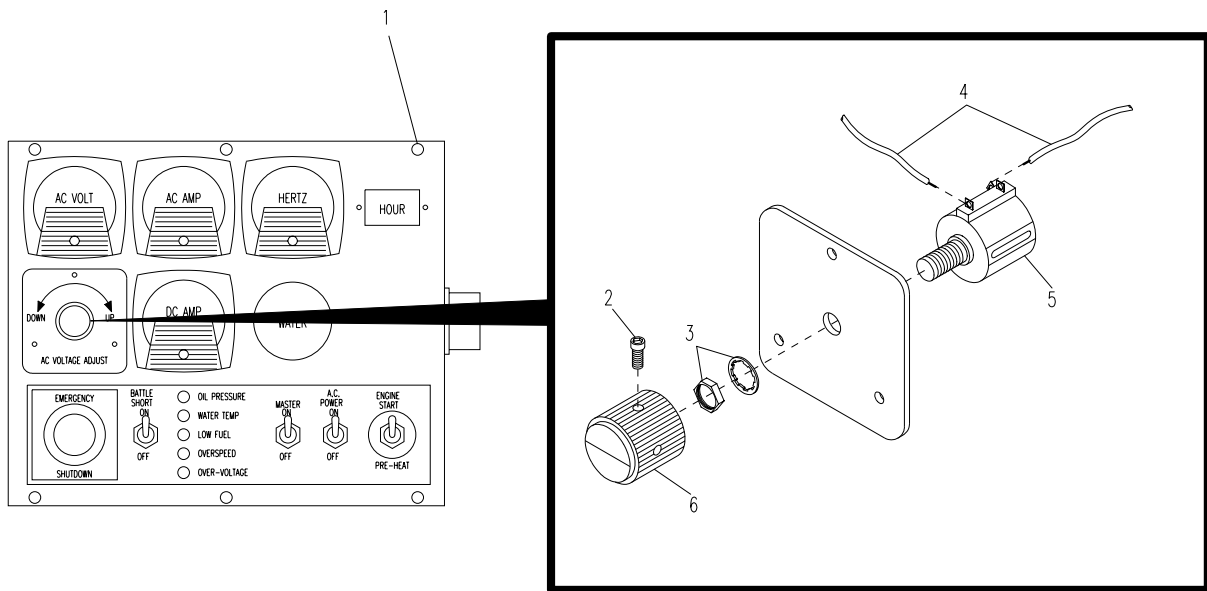

Figure 4-47. AC Voltage Adjust Potentiometer

4.60. EMERGENCY SHUT-DOWN SWITCH.

This task covers: a. Test b. Replace

INITIAL SETUP

Tools

General Mechanic's Tool Kit
(Item 1, Appendix B)

Shop Equipment, Electrical Repair
Semi trailer Mounted
(Item 3, Appendix B)

Materials/Parts

Emergency Shut-down Switch

Equipment Conditions

APU control unit disconnected from shelter.

TEST

- a. Tag and remove leads from emergency shut-down switch (perform steps a through c of REPLACE).
- b. Pull switch fully out.
- c. Refer to Figure FO-1 (SICPS/WIN-T) or F0-7 (JTACS) and use Multi-meter to test for continuity across switch terminals. If there is no continuity, replace switch.
- d. Push switch fully in.
- e. Refer to Figure FO-1 (SICPS/WIN-T) or F0-7 (JTACS) and use Multi-meter to test for no continuity across switch terminals. If there is continuity, replace switch.

REPLACE

- a. Remove ten screws (caged nuts (SICPS), machine screws (JTACS and WIN-T)) (1, Figure 4-48) securing APU control unit cover to chassis and remove cover.
- b. At rear of push button (2), identify and tag terminal leads (4).

NOTE

Do not remove screws (3).

- c. Loosen four screws (3) and remove terminal leads (4).
- d. At front panel, remove red knob (6) by turning ccw.
- e. Remove nut (5) securing push button (2) to APU control unit cover front panel. Remove push button.

- f. Position push button in APU control unit front panel mounting hole. Secure push button (2) to front panel with nut (5).
- g. Install red knob (6) over nut (5) and secure by turning cw.
- h. At rear of push button, connect terminal leads (4) with screws (3). Tighten screws (3). Remove tags.
- i. Secure APU control unit cover to chassis with ten screws (caged nuts (SICPS), machine screws (JTACS and WIN-T)) (1).
- j. Install APU control unit.

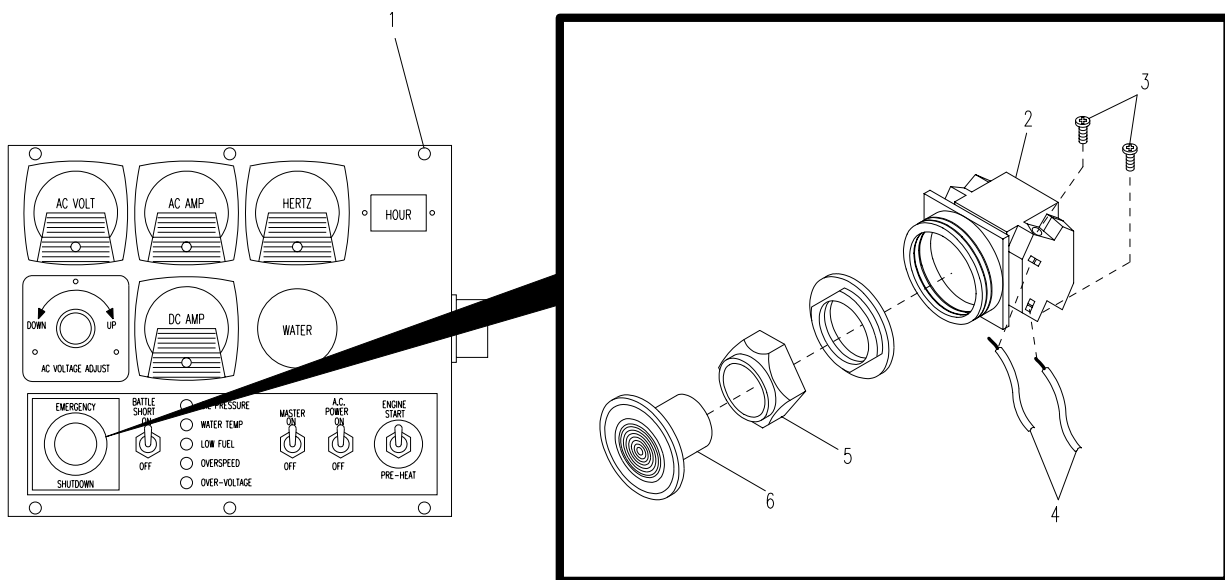

Figure 4-48. Emergency Shut-Down Switch

4.61. TOGGLE SWITCHES.

This task covers: a. Test b. Replace

INITIAL SETUP

Tools

General Mechanic's Tool Kit
(Item 1, Appendix B)

Shop Equipment, Electrical Repair,
Semitrailer Mounted
(Item 3, Appendix B)

Materials/Parts

Toggle Switches

Equipment Conditions

APU control unit disconnected from shelter.

TEST

- a. Tag and remove electrical leads from emergency shut-down switch (perform steps a through e of REPLACE).
- b. Place toggle switch (3) in ON position.
- c. Refer to Figure FO-1 (SICPS/WIN-T) or F0-7 (JTACS) and use Multi-meter to test for continuity across switch terminals. If there is no continuity, replace switch (3).
- d. Push switch in OFF position.
- e. Refer to Figure FO-1 (SICPS/WIN-T) or F0-7 (JTACS) and use Multi-meter to test for no continuity across switch terminals. If there is continuity, replace switch (3).

REPLACE

- a. Remove ten screws (caged nuts (SICPS), machine screws (JTACS and WIN-T)) (1, Figure 5-49) securing APU control unit cover to chassis and remove.
- b. At rear of switch (3), item (4), identify and tag terminal leads (5).
- c. Carefully cut away insulation sleeving and expose soldered connections.
- d. Unsolder and remove terminal leads (5) from switch terminals.
- e. Remove nut (2) securing switch (3) to APU control unit cover and remove.
- f. Place switch (3) through mounting hole in APU control unit cover and secure switch (3) to panel with nut (2).

- g. Identify terminal leads (5) to be soldered.
- h. Place insulation sleeving over each terminal lead and away from area to be soldered.
- i. Solder to terminal leads to appropriate terminals. Remove tags from terminal leads.
- j. Slide insulation sleeving over soldered connection. Use heat gun set on heat mode to shrink sleeving and secure soldered connection.
- k. Use heat gun set on cool mode to cool soldered connection and sleeving.
- l. Secure APU control unit cover to chassis with ten screws (caged nuts (SICPS), machine screws (JTACS and WIN-T)) (1).
- m. Install APU control unit.

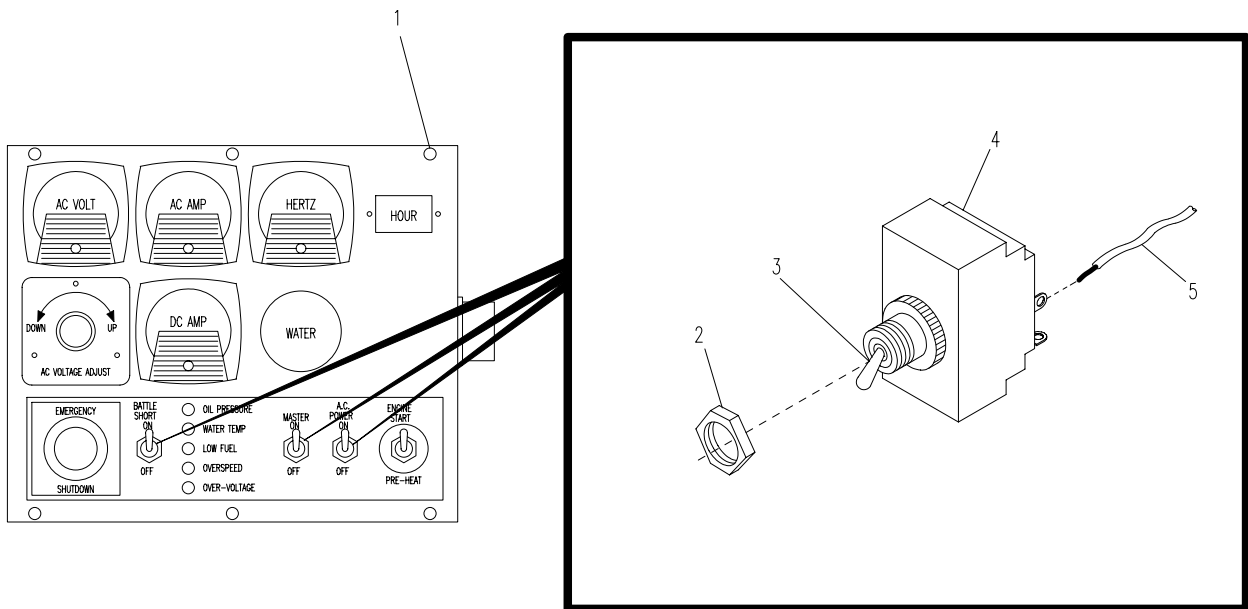

Figure 4-49. Toggle Switches

4.62. START-PREHEAT TOGGLE SWITCH.

This task covers: a. Test b. Replace

INITIAL SETUP

Tools

General Mechanic's Tool Kit
(Item 1, Appendix B)

Shop Equipment, Electrical, Repair,
Semitrailer Mounted
(Item 3, Appendix B)

Materials/Parts

Momentary Toggle Switch

Equipment Conditions

APU control unit disconnected from shelter.

TEST

- a. Tag and remove electrical leads from emergency shut-down switch (perform steps a through d of REPLACE).
- b. Refer to Figure FO-1 (SICPS/WIN-T) or F0-7 (JTACS). With START-PREHEAT toggle switch (3, Figure 4-50), in the OFF (center) position, use Multimeter to test for no continuity between center terminal and the upper and lower terminals. If continuity is observed, replace toggle switch.
- c. Place and hold START-PREHEAT switch (3) in up position and use Multi-meter to test for continuity across center and upper terminals. If there is no continuity, replace START-PREHEAT switch (3).
- d. Place and hold START-PREHEAT switch (3) in down position and use Multi-meter to test for continuity across center and lower terminals. If there is no continuity, replace START-PREHEAT switch (3).

REPLACE

- a. Remove ten screws (caged nuts (SICPS), machine screws (JTACS and WIN-T)) (1, Figure 4-50) securing APU control unit cover to chassis and remove.
- b. At rear of START-PREHEAT switch (3), item (4), identify and tag terminal leads (5).
- c. Carefully cut away insulation sleeving (SICPS only) and expose soldered connections.
- d. Unsolder and remove terminal leads (5) from terminals.
- e. Remove nut (2) securing START-PREHEAT switch (3) to APU control unit cover and remove.
- f. Place START-PREHEAT switch (3) through mounting hole and secure START-PREHEAT switch (3) to front panel with nut (2).
- g. At rear of START-PREHEAT switch (3, item 4), identify terminal leads (5).
- h. Place insulation sleeving (SICPS only) over terminal lead and away from area to be soldered.
- i. Solder terminal leads to appropriate switch terminals. Remove tags from terminal leads.

- j. Slide insulation sleeving over soldered connection. Use heat gun set on heat mode to shrink sleeving and secure soldered connection.
- k. Use heat gun set on cool mode to cool soldered connection and sleeving.
- l. Secure APU control unit cover to chassis with ten screws (caged nuts (SICPS), machine screws (JTACS and WIN-T)) (1).
- m. Install APU control unit.

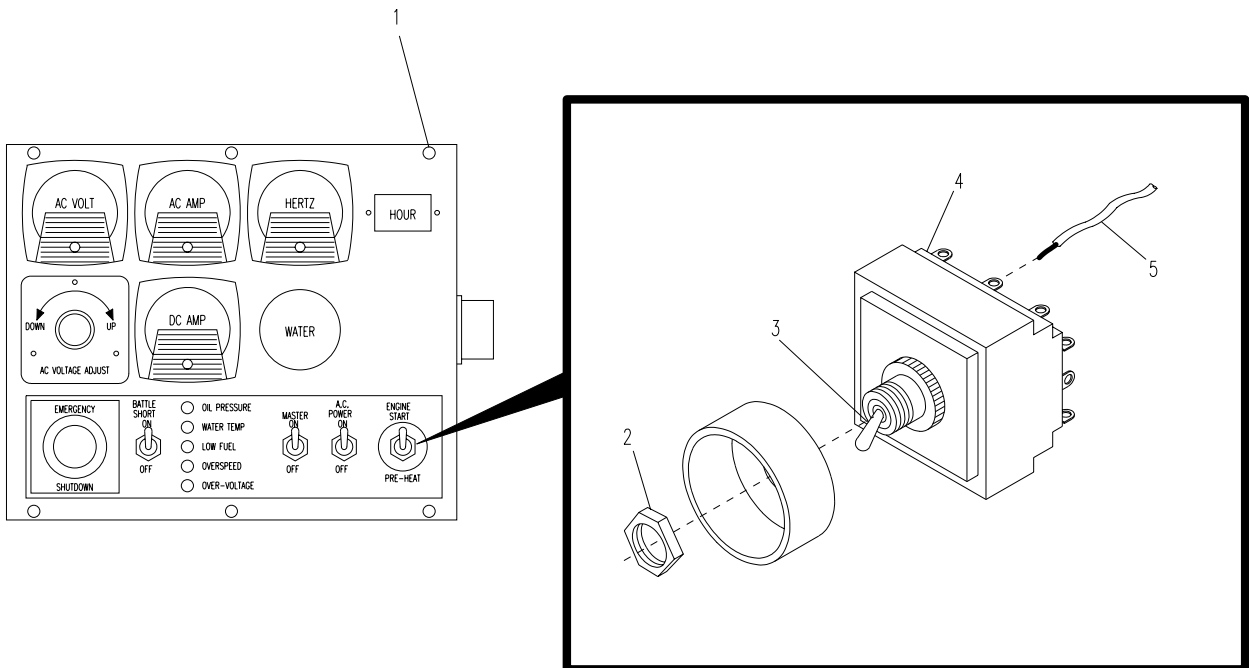

Figure 4-50. START-PREHEAT Toggle Switch

4.63. INDICATOR LAMPS.

This task covers: Replace

INITIAL SETUP

Tools

General Mechanic's Tool Kit
(Item 1, Appendix B)

Shop Equipment, Electrical Repair,
Semitrailer Mounted
(Item 3, Appendix B)

Materials/Parts

Indicator Lamps

Equipment Conditions

APU control unit disconnected from shelter.

REPLACE

- a. Remove ten screws (caged nuts (SICPS), machine screws (JTACS and WIN-T)) (1, Figure 4-51) securing APU control unit front cover to chassis and remove cover.
- b. At the rear of indicator light (3), identify and tag terminal leads (4).

NOTES

Terminal leads for indicator lamps in APU control units configured for the SICPS system are installed into terminal board TB1.

Refer to fold-out FO-1 (SICPS/WIN-T) or F0-7 (JTACS), then loosen appropriate screws in terminal board TB1 to remove or install indicator lamp leads.

SICPS personnel may skip steps c through f, and i through p.

- c. Identify terminal lead at rear of indicator light leading to terminal lead at rear of ENGINE START/PRE-HEAT switch.
- d. Carefully cut away insulation sleeving and expose soldered connection. Desolder connection.
- e. Identify second terminal lead at rear of indicator light connecting to terminal lead at APU connector.
- f. Carefully cut away insulation sleeving and expose soldered connection. Use soldering iron to unsolder connection.
- g. At rear of indicator light, tuck in plastic wings (2) and gently pull indicator light (3) forward through front panel.

- h. Place leads (4) and indicator light through hole in front panel and gently push light through until plastic wings (2) snap out and lock indicator light in place.
- i. Identify terminal lead (4) to be connected to terminal lead from rear of ENGINE START/PRE-HEAT SWITCH. Place insulation sleeving over terminal lead (4) and push sleeving away from area to be soldered.
- j. Use soldering iron to solder terminal lead (4) from indicator light to single terminal lead from ENGINE START/PRE-HEAT switch.
- k. Slide insulation sleeving over soldered connection and use heat gun to shrink sleeving and secure soldered connection.
- l. Use heat gun set on cool mode to cool soldered connection and sleeving.
- m. Identify second terminal lead (4) at rear of indicator light and place insulation sleeving over terminal lead and push sleeving away from areas to be soldered.
- n. Solder indicator light terminal lead (4) to appropriate terminal lead at APU connector. Remove all tags from leads.
- o. Slide insulation sleeving over soldered connection. Use heat gun to shrink sleeving and secure soldered connection.
- p. Use heat gun set on cool mode to cool soldered connection and sleeving.
- q. Secure APU control unit cover to chassis with ten screws (1).
- q. Install APU control unit (see system TM).

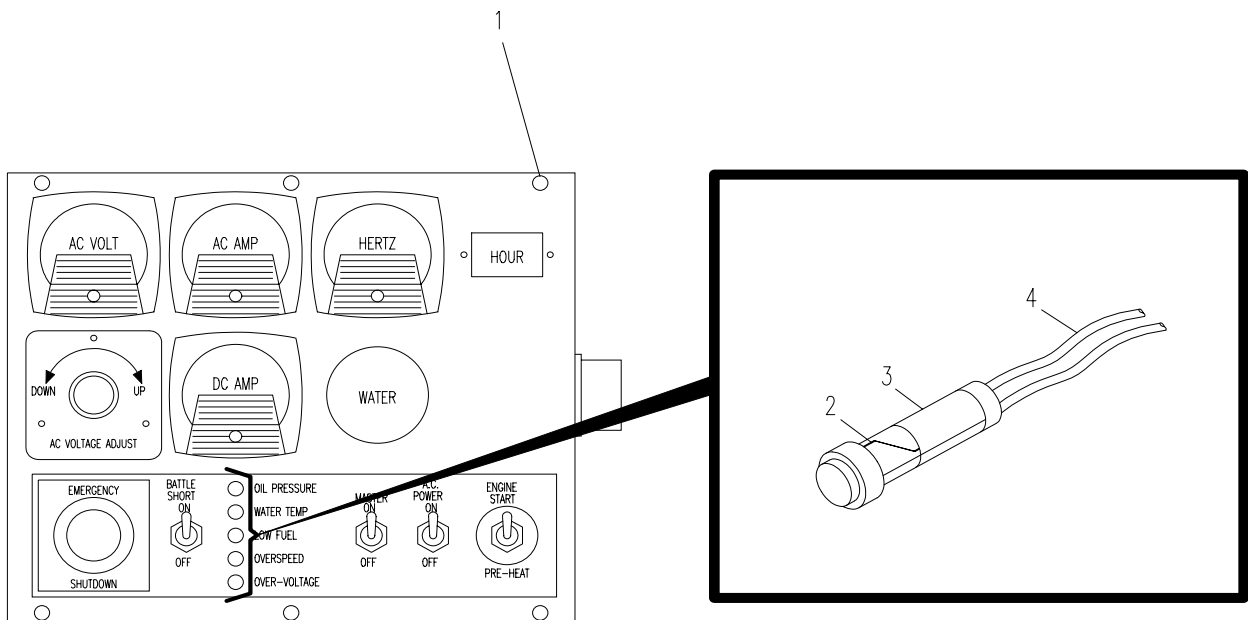

Figure 4-51. Indicator Lamps

4.64. CYLINDER HEAD COVER (VALVE COVER).

This task covers: a. Replace

INITIAL SETUP

Tools

General Mechanic's Tool Kit
(Item 1, Appendix B)

Torque Wrench
(Item 2, Appendix B)

Materials/Parts

Cylinder Head Cover
Cylinder Head Cover Gasket

Equipment Condition

Engine stopped and allowed to cool completely.

MASTER ON/OFF switch off on APU control unit set to OFF.

Air intake pipe removed (para 4.47.).

REPLACE

- a. Remove three cap nuts, washer gaskets (1), and cylinder head cover (2).
- b. Remove cylinder head cover gasket (3).
- c. Install cylinder head cover gasket (3).
- d. Align three mounting studs (4) with holes in cylinder head cover (2) and install cylinder head cover (2).
- e. Secure cylinder head cover (2) with three cap nuts and three washer gaskets (1). Torque between 2.9 and 4.3 ft-lbs (3.9 to 5.9 Nm).

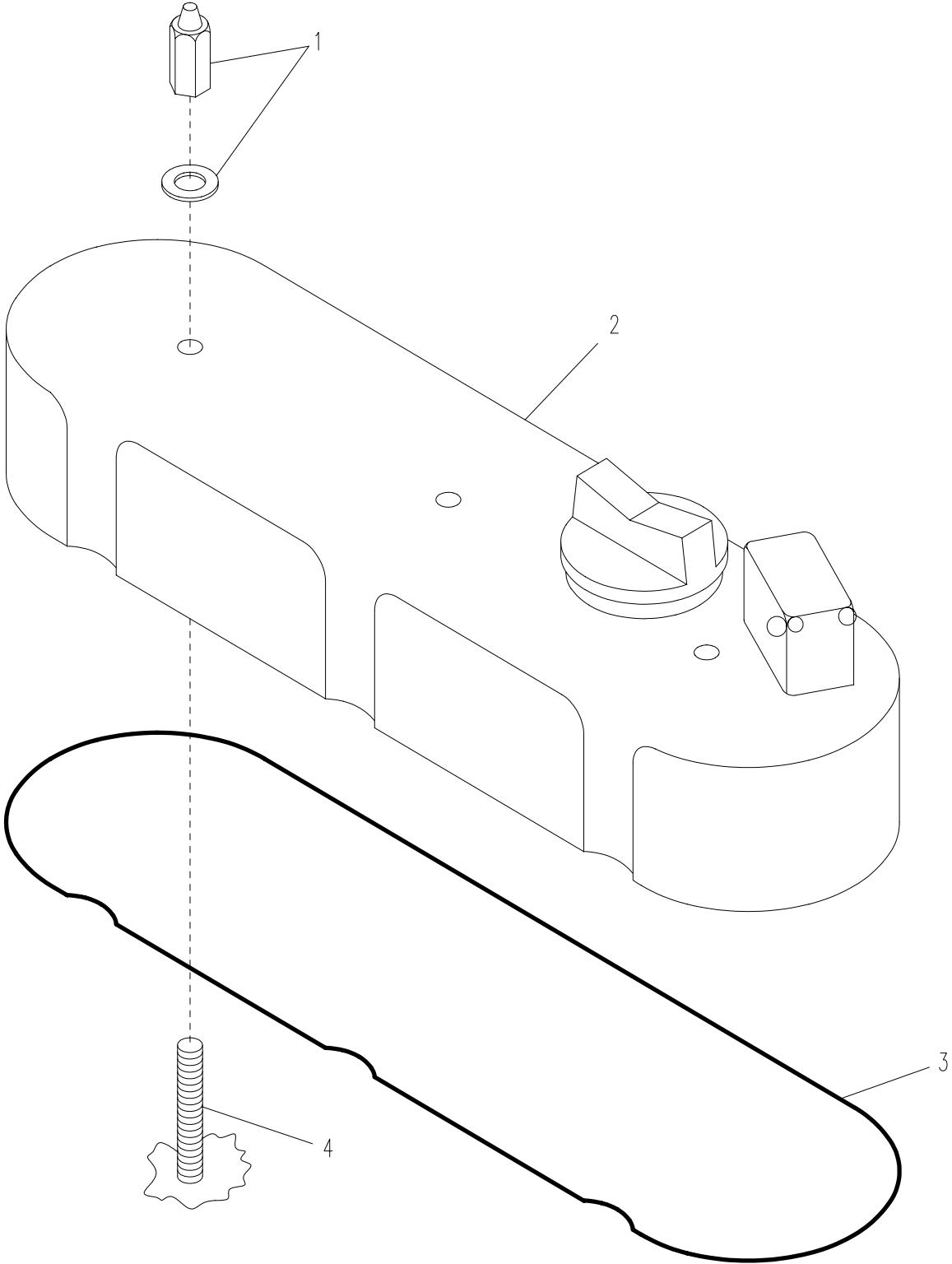

Figure 4-52. Cylinder Head Cover (Valve Cover)

THIS PAGE INTENTIONALLY LEFT BLANK.

CHAPTER 5

DIRECT SUPPORT MAINTENANCE INSTRUCTIONS

	Page
Section I. Repair Parts; Special Tools; Test, Measurement, and Diagnostic Equipment (TMDE); and Support Equipment	5-2
5.1. Common Tools and Equipment	5-2
5.2. Special Tools, TMDE, and Support Equipment.....	5-2
5.3. Repair Parts.....	5-2
Section II. Direct Support Troubleshooting	5-2
5.4. General.....	5-2
5.5. Direct Support Troubleshooting Procedures	5-2
Section III. Direct Support Maintenance Procedures	5-24
5.6. Auxiliary Power Unit.....	5-24
5.7. Oil Pan Cover	5-25
5.8. Oil Pan	5-27
5.9. Oil Pan Strainer	5-29
5.10. Relief Valve.....	5-31
5.11. Radiator Cap.....	5-32
5.12. Water Pump.....	5-33
5.13. Injection Nozzle Assembly	5-35
5.14. Injection Pump	5-39
5.15. Current Transformer	5-45
5.16. Overload Relay	5-46
5.17. Contactor Plate	5-48
5.18. Relay Board	5-50
5.19. DC Box Subassembly	5-53
5.20. Electromagnetic Safety Relays.....	5-55
5.21. Relay Sockets.....	5-58
5.22. Automatic Voltage Regulator	5-60
5.23. Regulator Box	5-64
5.24. Generator, 10 kW, 60 Hz	5-67
5.25. Wiring Harness Repair.....	5-76
5.26. APU DC Box Wiring Harness J3.....	5-78
5.27. Wiring Harness, Engine P1.....	5-82
5.28. Wiring Harness J1	5-86
5.29. Wiring Harness Control Cable	5-90
5.30. Water Temperature Gauge.....	5-92
5.31. Wiring Harness J2	5-95
5.32. Frame Assembly (Models MEP-903A, MEP-903B, and MEP-903C) and Vibration Isolator Mount Assembly	5-99
5.33. Diesel Engine.....	5-110
5.34. Exhaust Manifold	5-125
5.35. Intake Manifold	5-127
5.36. Rocker Arm Assembly	5-129
5.37. Valve Clearance	5-131
5.38. Flywheel.....	5-134

NOTE

Refer to "Table 1-1. Differences Between Models" for differences between MEP-903A, MEP-903B, and MEP-903C, which may not be depicted in the TM illustrations.

Section I. REPAIR PARTS; SPECIAL TOOLS; TEST, MEASUREMENT, AND DIAGNOSTIC EQUIPMENT (TMDE); AND SUPPORT EQUIPMENT

5.1. COMMON TOOLS AND EQUIPMENT.

For authorized common tools and equipment, refer to the Modified Table of Organization and Equipment (MTOE), CTA 50-970, or CTA 8-1010 as applicable to your unit.

5.2. SPECIAL TOOLS, TMDE, AND SUPPORT EQUIPMENT.

For listing of special tools, TMDE, and support equipment authorized for use on this equipment, refer to Appendix C, Repair Parts and Special Tools List (RPSTL), and Appendix B, Maintenance Allocation Chart, of this manual.

5.3. REPAIR PARTS.

Repair parts are listed and illustrated in Appendix C, Repair Parts and Special Tools List, of this manual.

Section II. DIRECT SUPPORT TROUBLESHOOTING

5.4. GENERAL.

This section contains troubleshooting procedures to determine the probable cause of observed equipment malfunctions. Branching logic trees are provided to isolate the faulty component and offer corrective actions to eliminate the malfunction.

5.5. DIRECT SUPPORT TROUBLESHOOTING PROCEDURES.

The following pages list common malfunctions that may occur during operation or maintenance of the Auxiliary Power Unit 10 kW, 120/240 VAC, 60 Hz (APU), followed by a troubleshooting procedure. Refer to the symptom index to locate the troubleshooting procedure for the malfunction you observe. Each troubleshooting procedure consists of a branching logic tree. Perform the test or inspection, and the recommended corrective action in the order listed in the logic tree. If the malfunction is corrected by a specific corrective action, do not continue with any remaining steps. But if the corrective actions do not correct the malfunction, notify the next higher level of maintenance.

SYMPTOM INDEX

Symptom	Page
1. Engine fails to turn over.....	5-4
2. Engine turns over but fails to start.....	5-5
3. Engine starts, but stops when start-preheat switch is released.....	5-6
4. Engine stops suddenly.....	5-7
5. Engine runs erratically or misfires.....	5-8
6. Engine does not develop full power.....	5-9
6a. Engine knocks.....	5-9
7. Black smoke in exhaust.....	5-10
8. Blue or white smoke in exhaust.....	5-11
9. Low oil pressure.....	5-11
10. Engine overheating.....	5-12
11. Engine coolant temperature too low.....	5-13
12. DC ammeter shows no charge when vehicle battery is low or discharged.....	5-13
13. DC ammeter shows excessive charging after prolonged APU operation.....	5-14
14. Excessive oil consumption.....	5-15
14a. High oil pressure.....	5-15
15. Fuel mixed into lubricant oil.....	5-16
16. Coolant mixed into lubricant oil.....	5-16
17. AC voltmeter does not indicate voltage.....	5-17
18. AC voltmeter indicates voltage but frequency meter is off scale.....	5-18
19. AC voltage fluctuates.....	5-19
20. Frequency fluctuates.....	5-20
21. Main AC contactor will not close.....	5-21
22. Oil pressure fault indicator lights.....	5-21
23. Water temp fault indicator lights.....	5-21
24. Overspeed fault indicator lights.....	5-22
25. Over-voltage fault indicator lights.....	5-23

1. ENGINE FAILS TO TURN OVER.

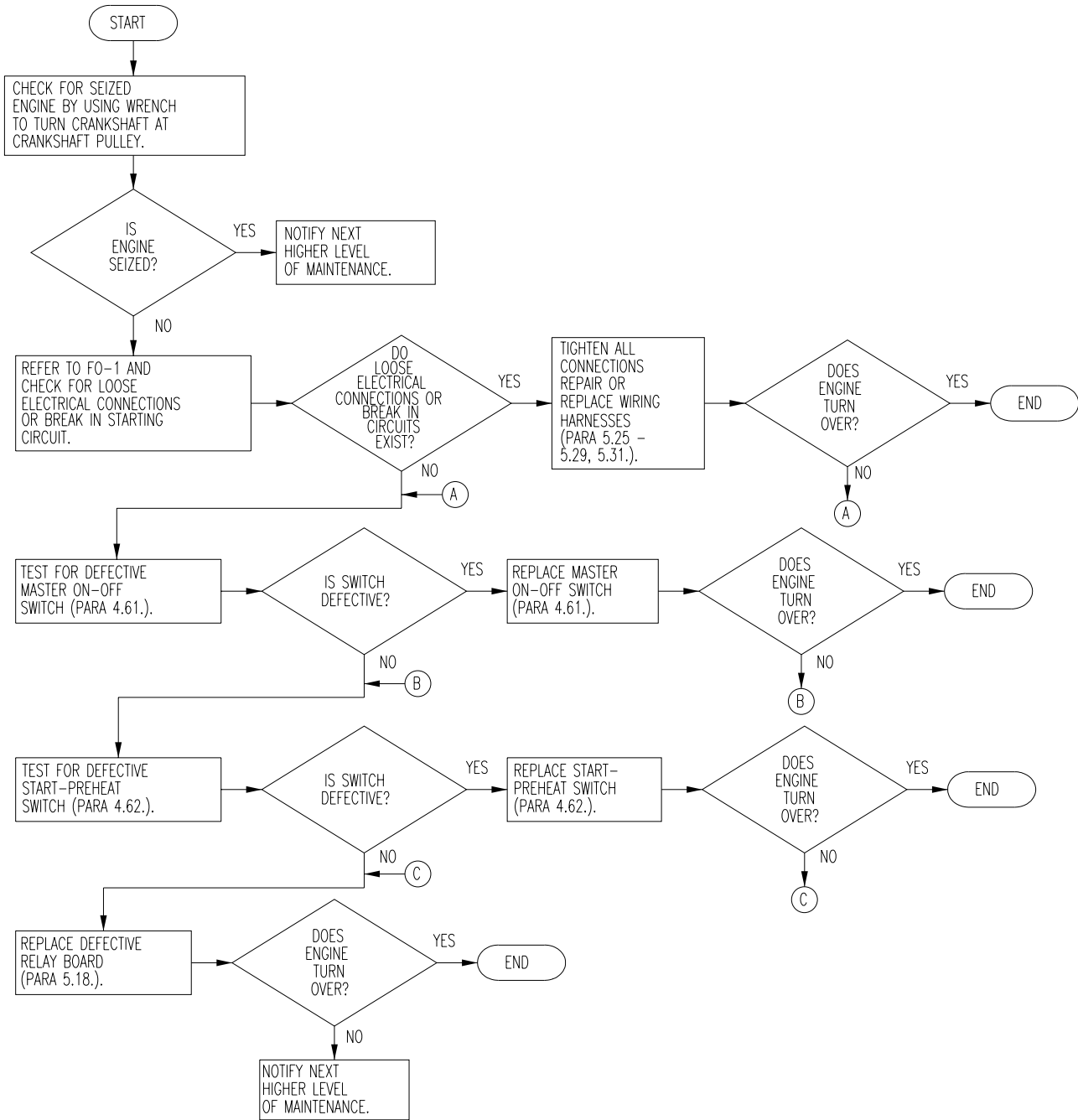

2. ENGINE TURNS OVER BUT FAILS TO START.

STEP 1. Check to see if proper starting procedures were followed.

- a. If proper starting procedures were not followed, start APU per para. 2-5.
- b. If proper starting procedures were followed, proceed to step 2.

STEP 2. Check for low or no vehicle fuel supply.

- a. If vehicle fuel tank is low, service vehicle fuel tank.
- b. If vehicle fuel tank has adequate amount of fuel, proceed to step 3.

STEP 3. Check for closed Selector valve on fuel filter.

- a. If fuel selector valve is closed, open fuel selector valve.
- b. If fuel selector valve is open, proceed to step 4.

STEP 4. Check for defective injection timing.

- a. If injection timing is not correct, ADJUST timing (para. 5.14.).
- b. If injection timing is correct, proceed to step 5.

STEP 5. Check for defective injection pump.

- a. If injection pump is defective, REPLACE pump (para. 5.14.).
- b. If injection pump is functioning properly, proceed to step 6.

STEP 6. Check for defective injection nozzle holder assembly.

- a. If injection nozzle(s) clogged, clean nozzle(s). If nozzle holder assembly is defective, REPLACE holder assembly (para. 5.13.).
- b. If nozzle holder assembly is functioning properly and injection nozzle(s) unclogged, proceed to step 7.

STEP 7. Check for excessive valve clearance.

- a. If valve clearance exceeds tolerance, ADJUST clearance (para. 5.29.).
- b. If valve clearance meets tolerance, notify next higher level of maintenance.

3. ENGINE STARTS, BUT STOPS WHEN START-PREHEAT SWITCH IS RELEASED.

STEP 1. Check to see if START-PREHEAT SWITCH was held in the start position long enough.

- a. If START-PREHEAT SWITCH was not held in start position long enough, restart generator using procedures in TM holding switch in start position longer.
- b. If START-PREHEAT SWITCH was held long enough, proceed to step 2.

STEP 2. Check for adequate fuel level in vehicle fuel tank.

- a. If vehicle fuel tank is low, service vehicle fuel tank.
- b. If vehicle fuel tank has adequate amount of fuel, proceed to step 3.

STEP 3. Check for restricted air filter. Inspect Air Flow Restriction Indicator (SICPS only) and visually inspect air filter element.

- a. If the air filter is restricted or the filter element is dirty, SERVICE Air Filter.
- b. If the Air Filter is clean and not restricted, proceed to step 4.

STEP 4. Check for low oil level (Para. 3.6).

- a. If engine oil level is low, SERVICE engine oil (Para. 3.6).
- b. If engine oil level is between notches on the oil dipstick, notify next higher level of maintenance.

4. ENGINE STOPS SUDDENLY.

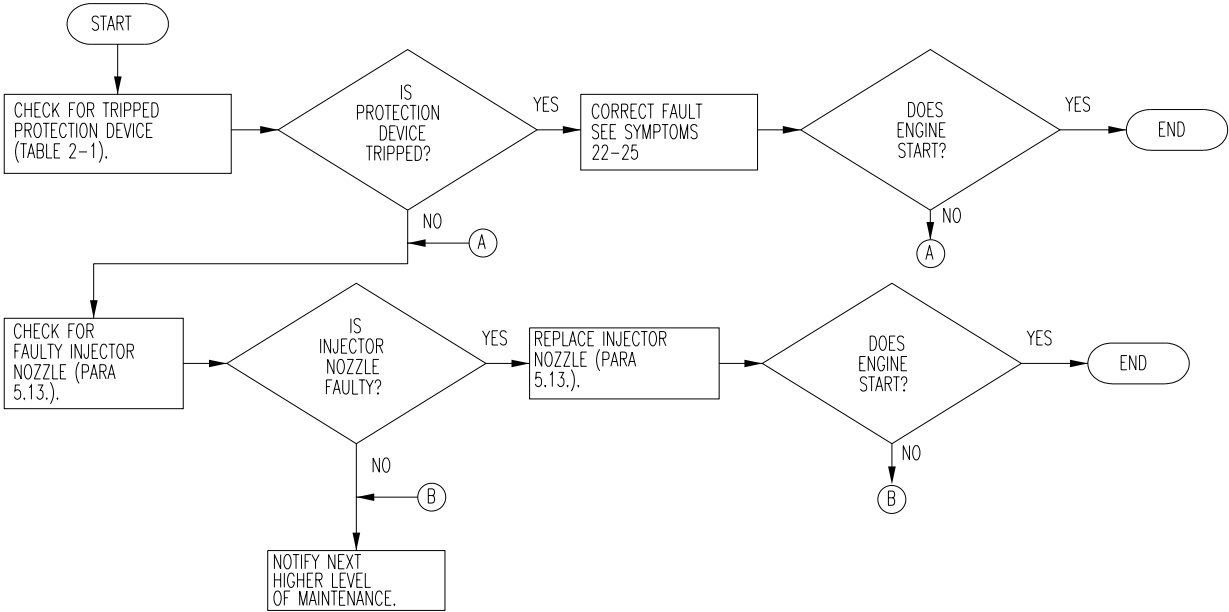

5. ENGINE RUNS ERRATICALLY OR MISFIRES.

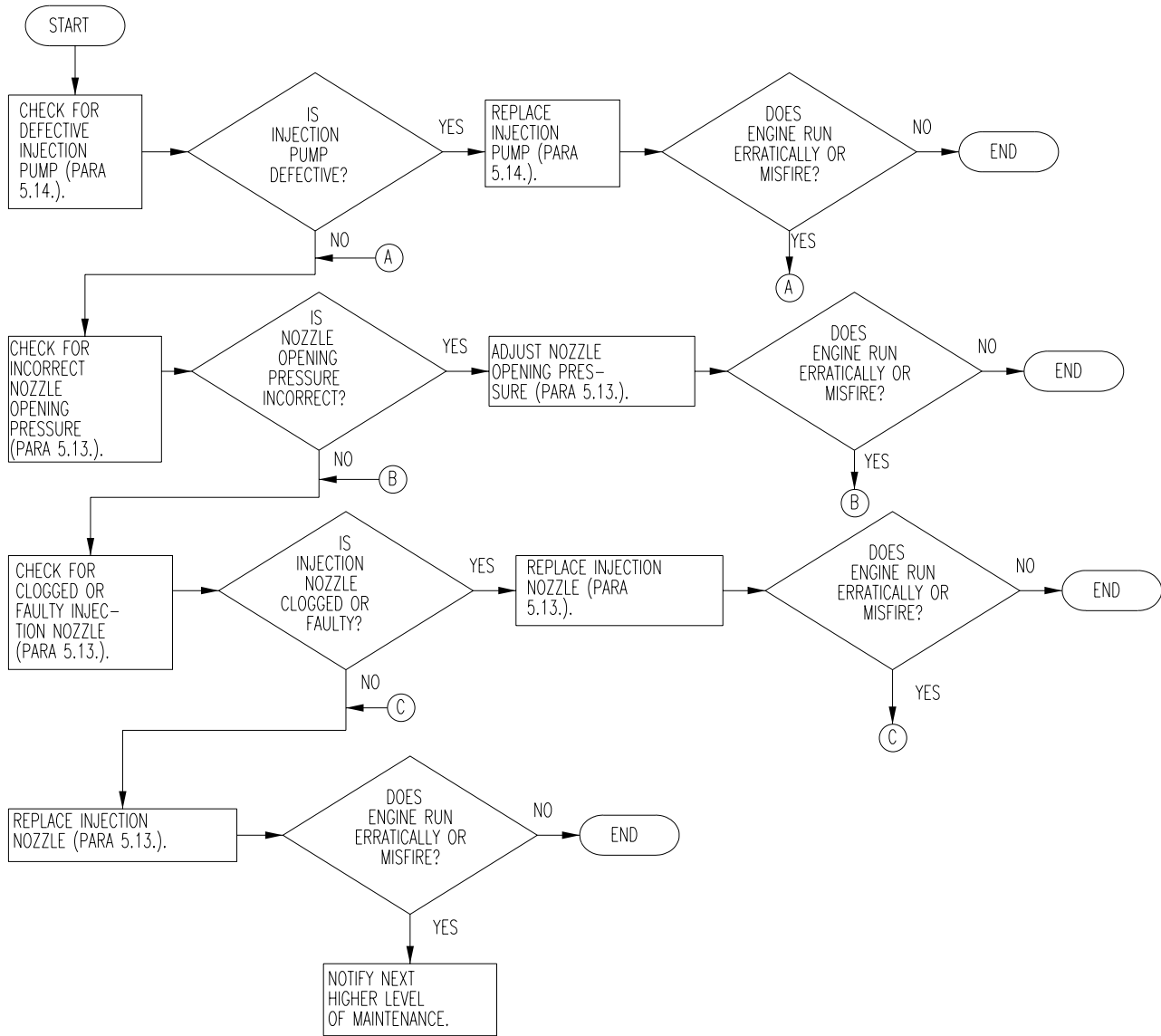

6. ENGINE DOES NOT DEVELOP FULL POWER.

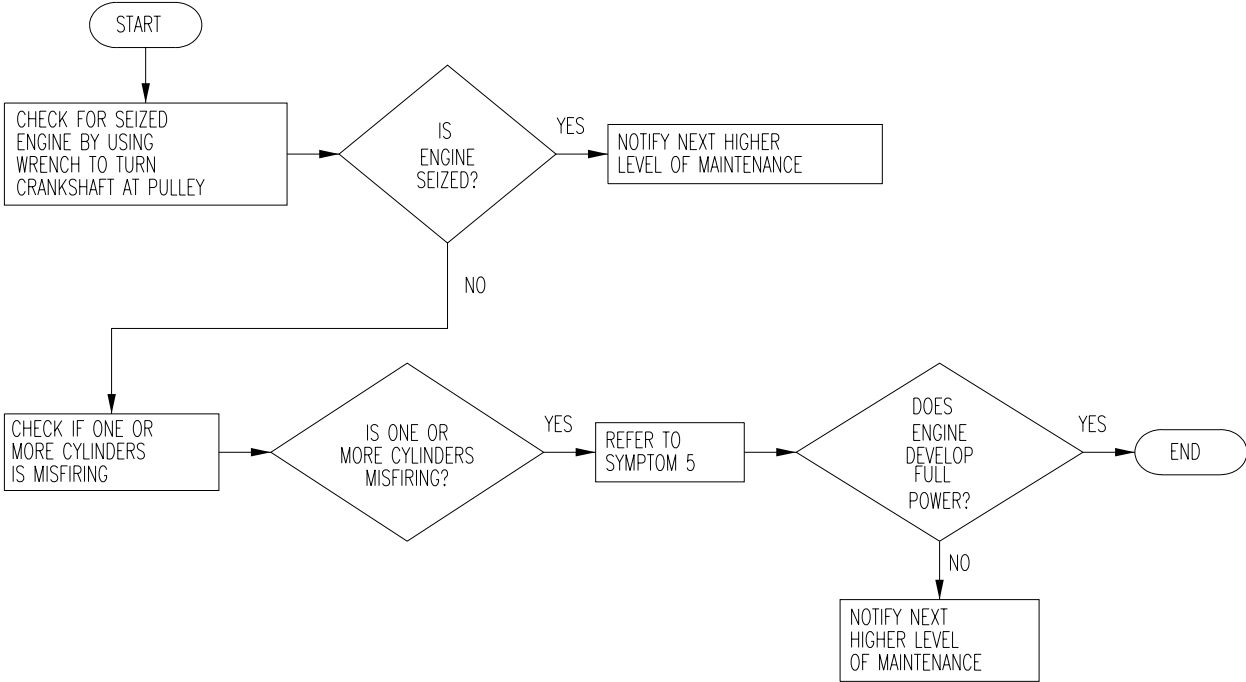

6a. ENGINE KNOCKS.

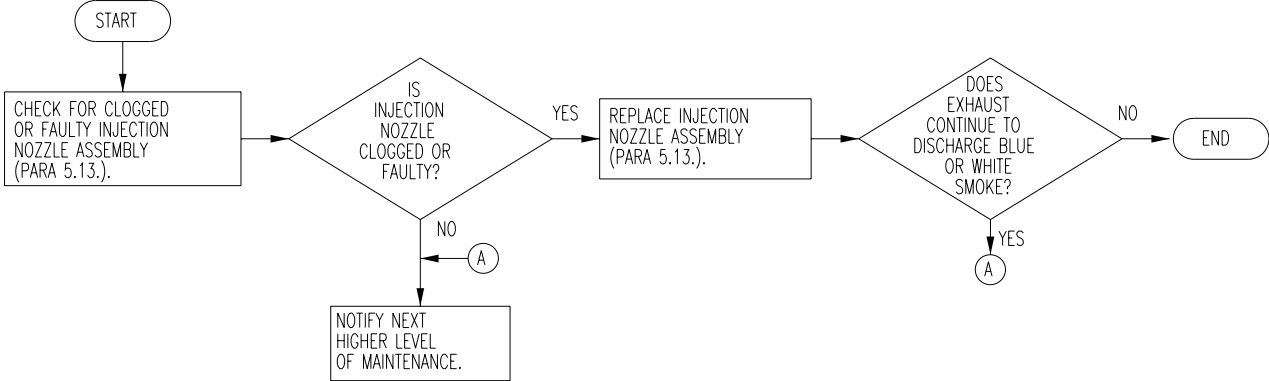

7. BLACK SMOKE IN EXHAUST.

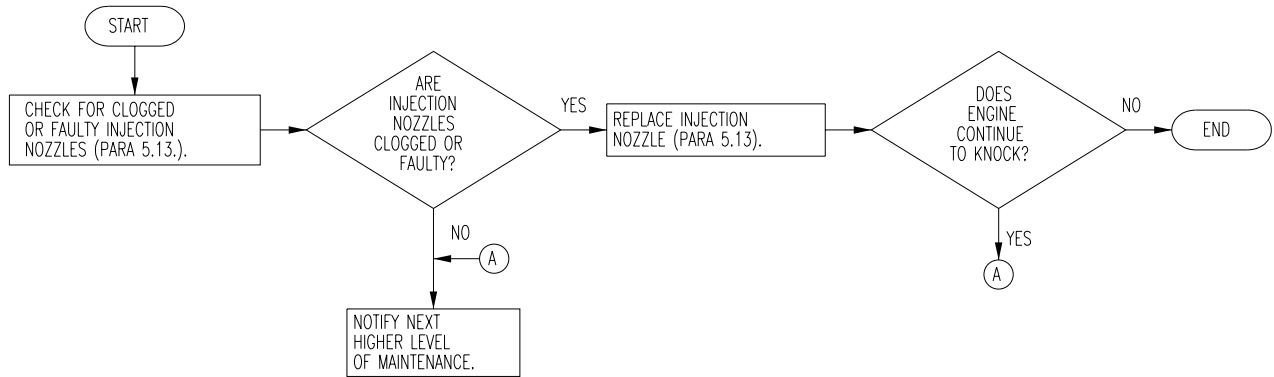

8. BLUE OR WHITE SMOKE IN EXHAUST.

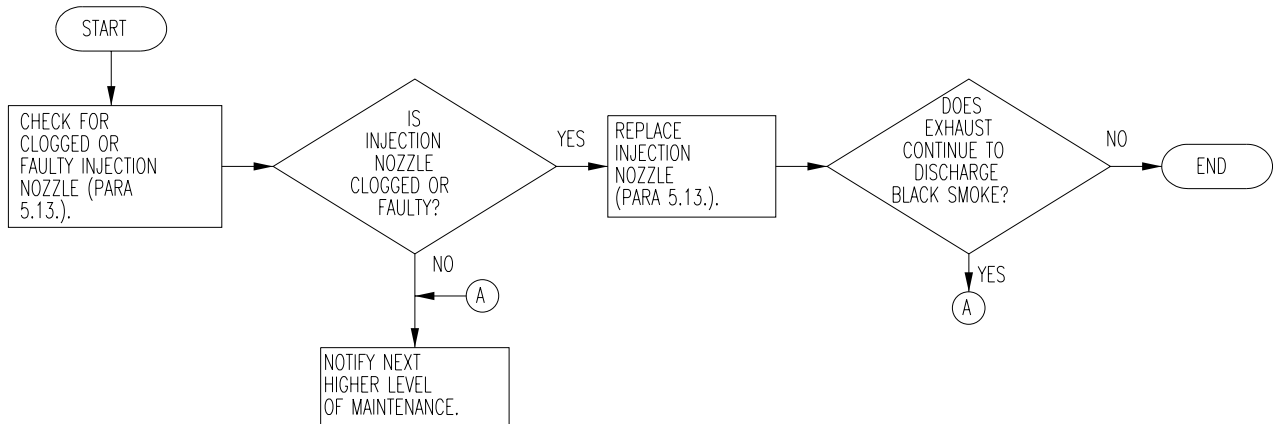

9. LOW OIL PRESSURE.

STEP 1. Check for stuck or faulty relief valve and spring (para. 5.10.).

- a. If the relief valve is stuck or faulty, replace relief valve and spring (para. 5.10.) and recheck for low oil pressure.
- b. If the relief valve is not stuck or faulty, proceed to step 2.

STEP 2. Check for excessive oil clearance of rocker arm assembly (para. 5.36.).

- a. If oil clearance exceeds tolerance, REPLACE rocker arm bearing (para. 5.36.).
- b. If oil clearance meets or is within tolerance, notify next higher level of maintenance.

10. ENGINE OVERHEATING.

STEP 1. Check radiator for low coolant level.

- a. If coolant level is low, SERVICE Radiator (para. 3.8.).
- b. If coolant level is adequate, proceed to step 2.

STEP 2. Check for sufficient oil in engine (para. 3.6.).

- a. If engine oil is low, SERVICE engine oil (para. 3.6.).
- b. If engine oil is adequate, proceed to step 3.

STEP 3. Check for air flow restriction through generator compartment and radiator.

- a. If air flow is restricted through generator compartment or radiator, remove restrictions.
- b. If air flows unrestricted through generator compartment and radiator, proceed to step 4.

STEP 4. Check for APU overload.

- a. If generator is overloaded, reduce load below rated generator power.
- b. If generator is not overloaded, proceed to step 5.

STEP 5. Check for defective water pump.

- a. If water pump is defective, REPLACE pump (para 5.12.).
- b. If water pump is functioning properly, proceed to step 6.

STEP 6. Check for defective injection timing.

- a. If injection timing is incorrect, ADJUST timing (para 5.14.).
- b. If injection timing is correct, notify next higher level of maintenance.

11. ENGINE COOLANT TEMPERATURE TOO LOW.

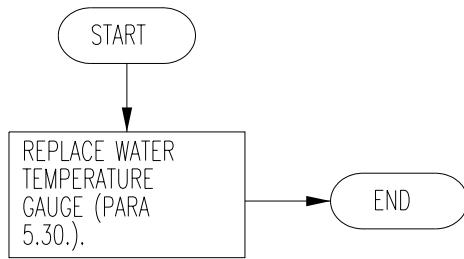

12. DC AMMETER SHOWS NO CHARGE WHEN VEHICLE BATTERY IS LOW OR DISCHARGED.

STEP 1. Check for dry or defective vehicle batteries.

- a. If batteries are dry or defective, contact Unit Maintenance and SERVICE or REPLACE batteries.
- b. If batteries are full and not defective, notify next higher level of maintenance.

13. DC AMMETER SHOWS EXCESSIVE CHARGING AFTER PROLONGED APU OPERATION.

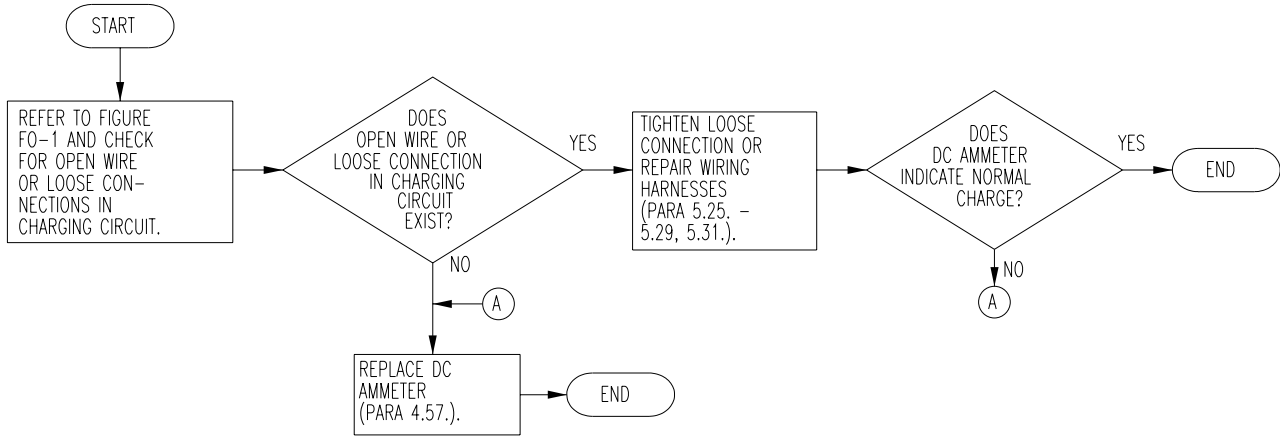

14. EXCESSIVE OIL CONSUMPTION.

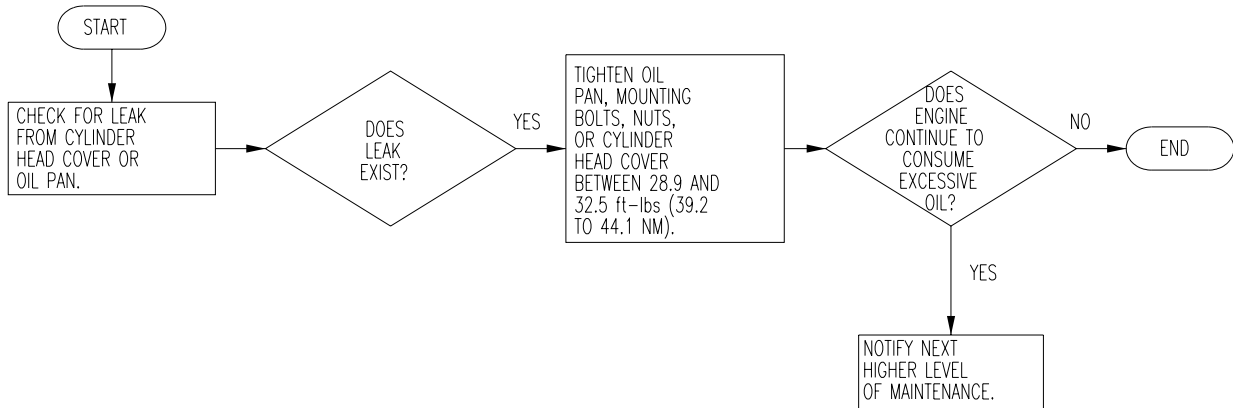

14a. HIGH OIL PRESSURE.

STEP 1. Check for faulty relief valve (para 5.10.)

- a. If the relief valve is faulty, REPLACE relief valve (para 5.10.).
- b. If the relief valve is not faulty, notify next higher level of maintenance.

15. FUEL MIXED INTO LUBRICANT OIL.

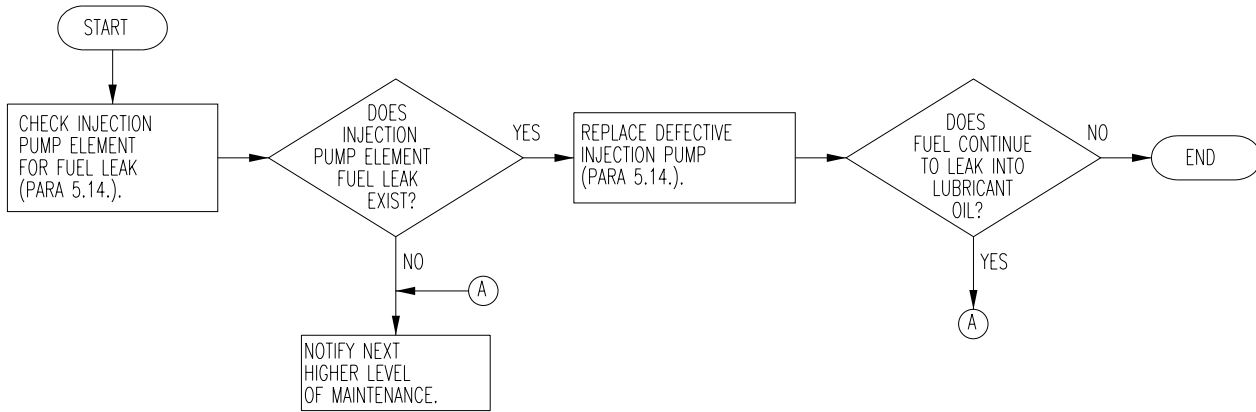

16. COOLANT MIXED INTO LUBRICANT OIL.

Notify next higher level of maintenance.

17. AC VOLTMETER DOES NOT INDICATE VOLTAGE.

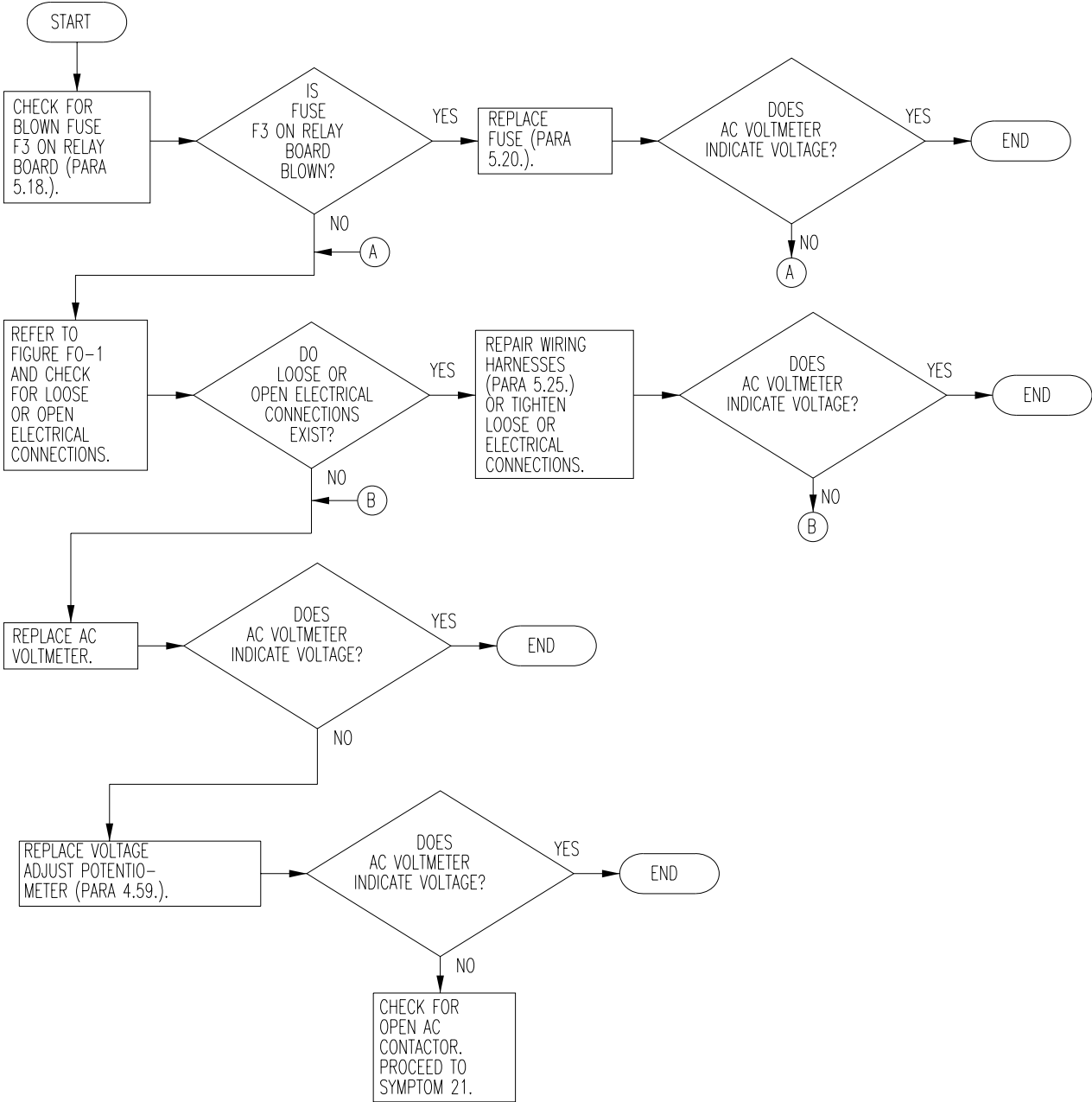

18. AC VOLTMETER INDICATES VOLTAGE BUT FREQUENCY METER IS OFF SCALE.

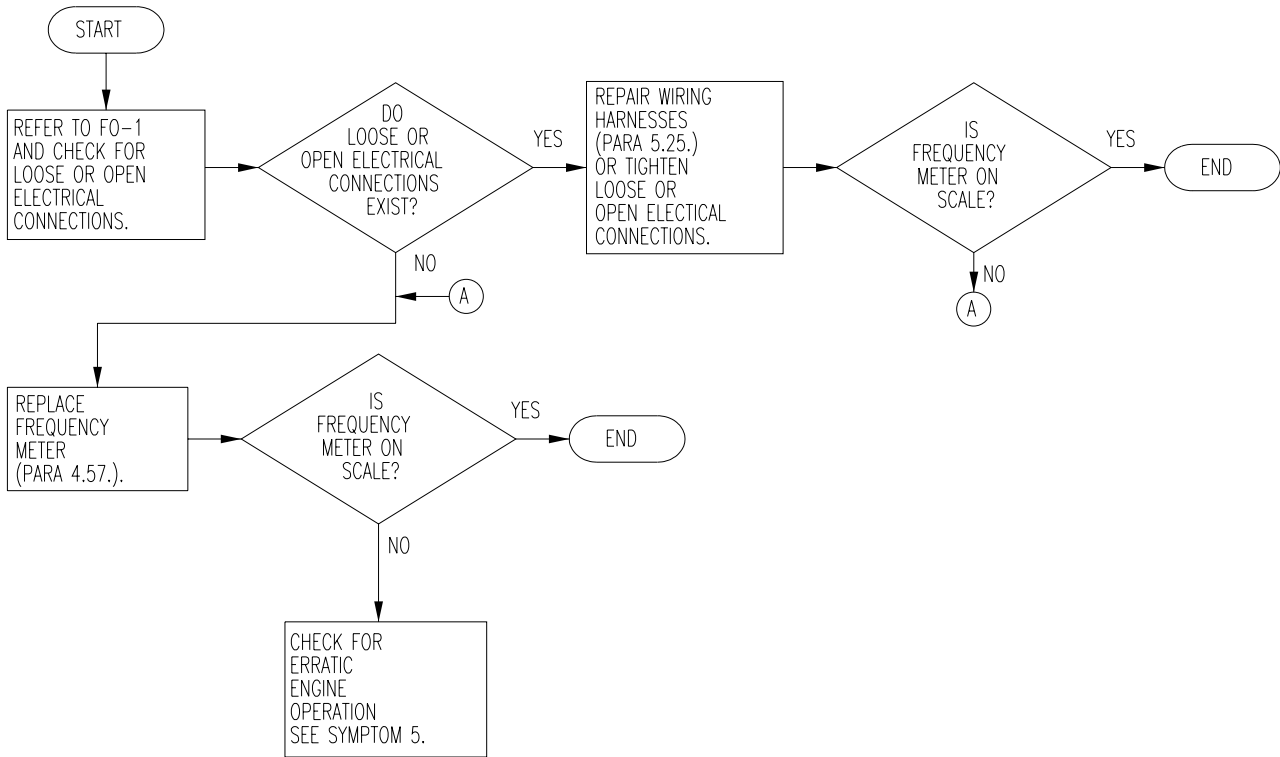

19. AC VOLTAGE FLUCTUATES.

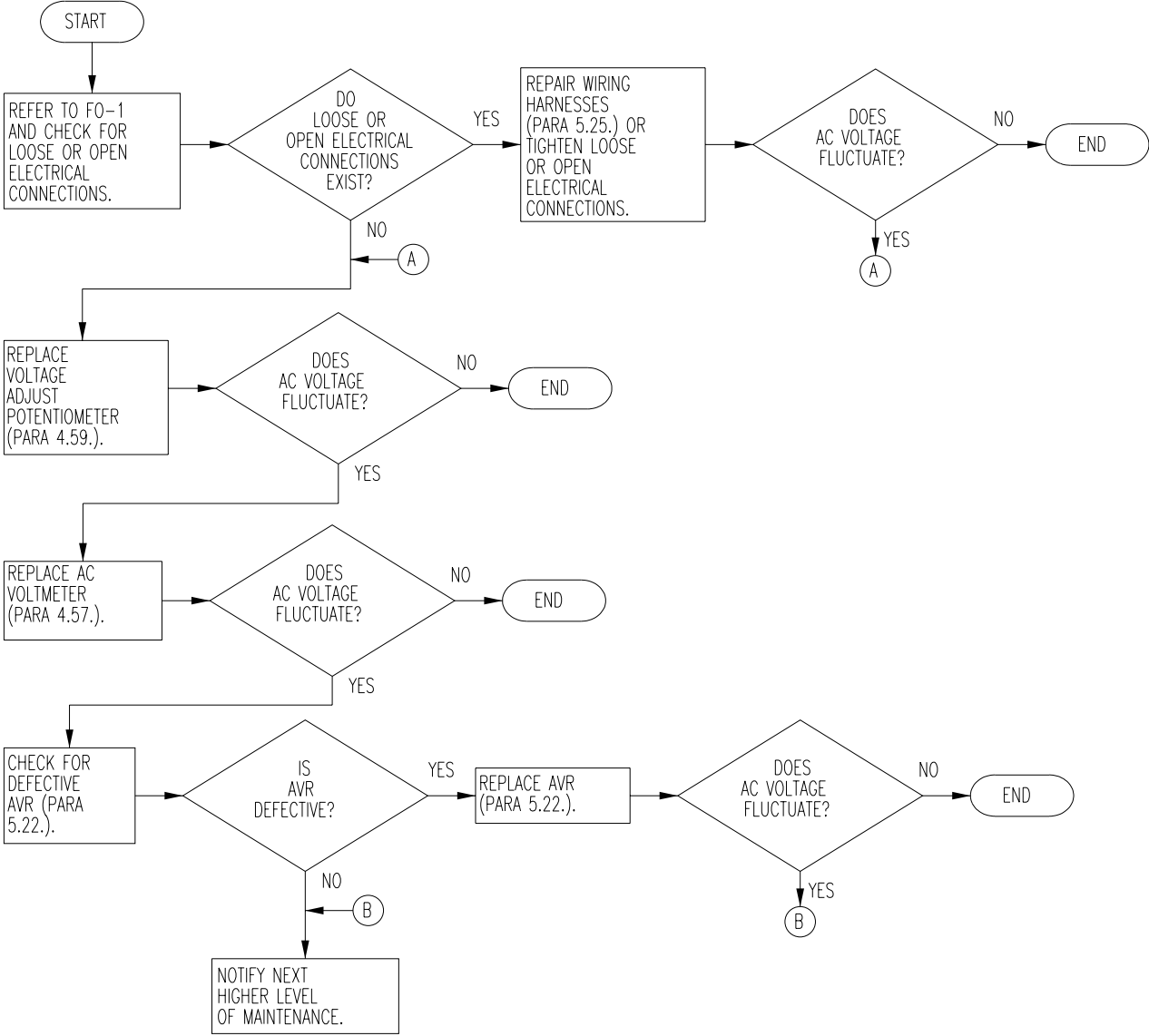

20. FREQUENCY FLUCTUATES.

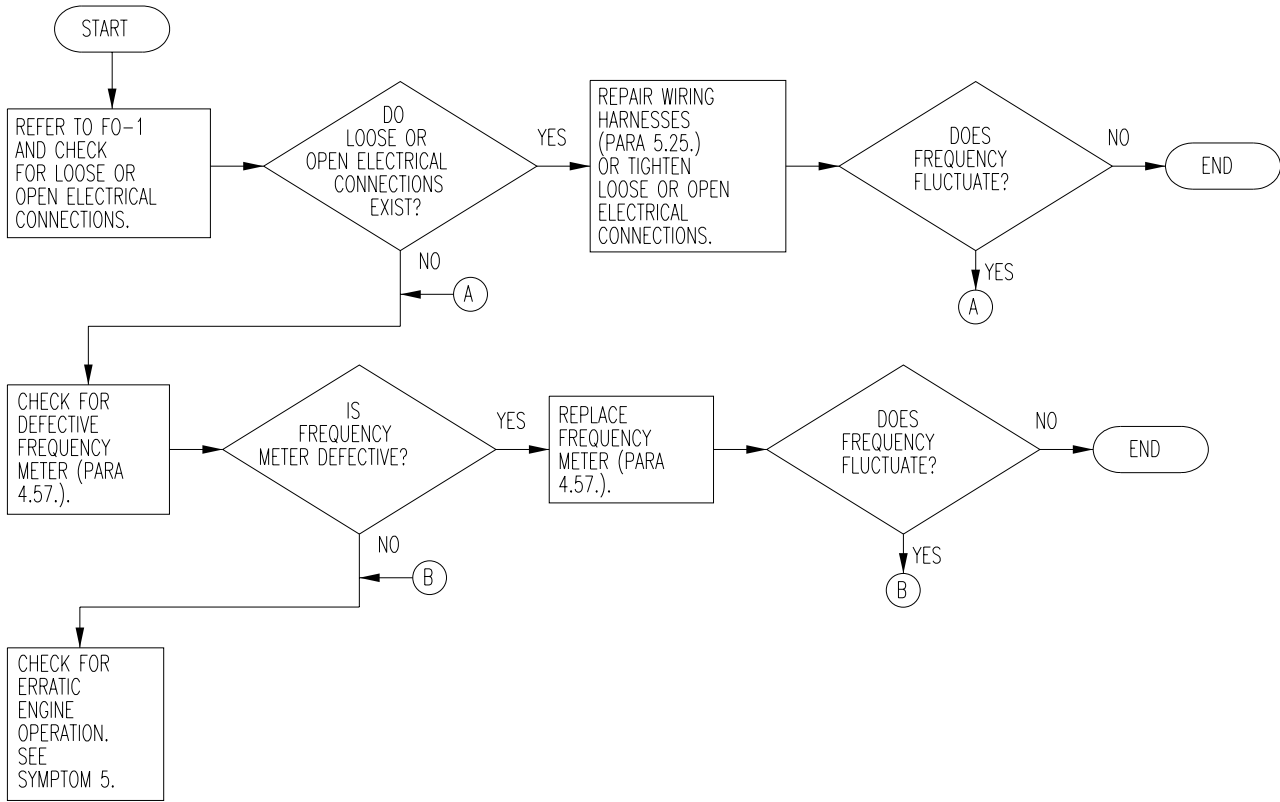

21. MAIN AC CONTACTOR WILL NOT CLOSE.

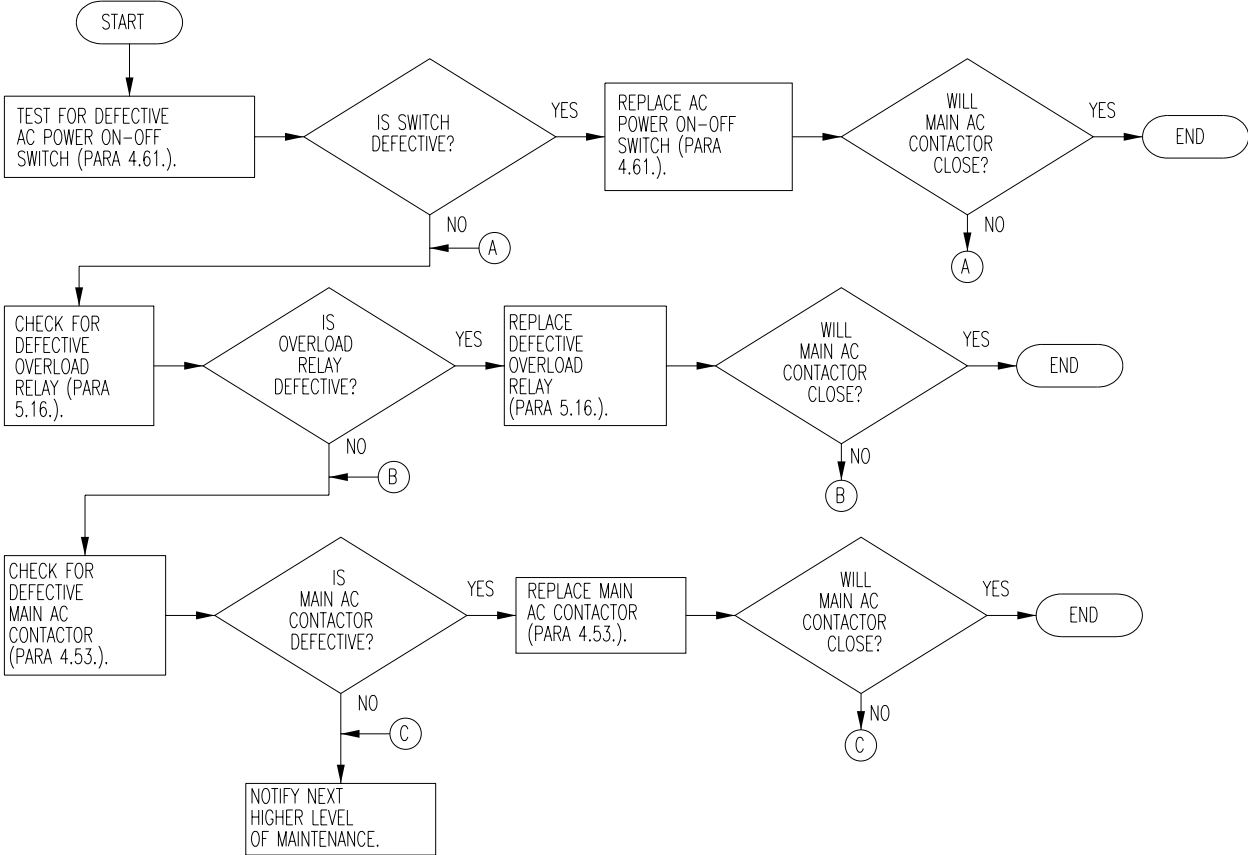

22. OIL PRESSURE FAULT INDICATOR LIGHTS.

Notify next higher level of maintenance.

23. WATER TEMP FAULT INDICATOR LIGHTS.

See Symptom 10.

24. OVERSPEED FAULT INDICATOR LIGHTS.

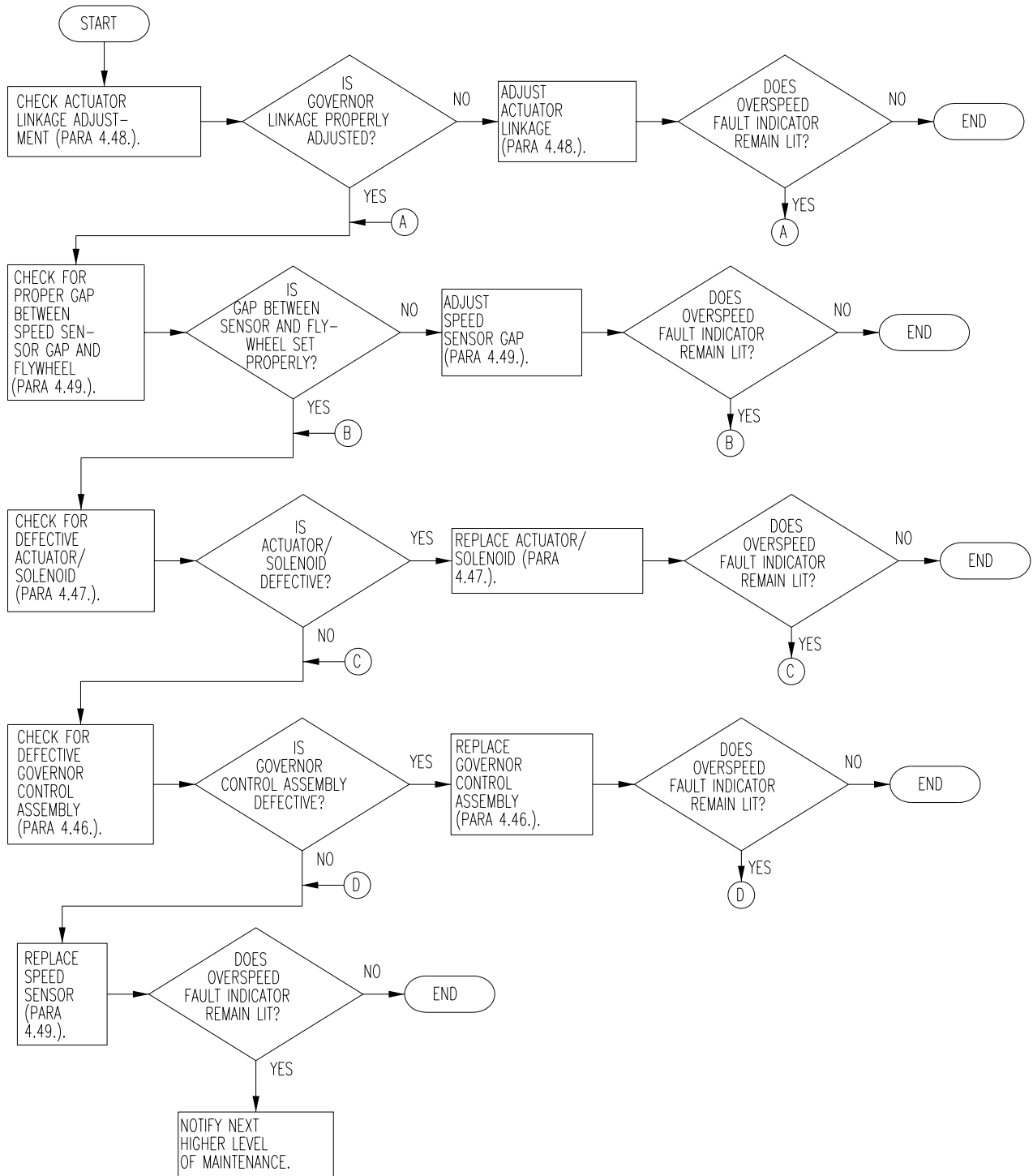

25. OVER-VOLTAGE FAULT INDICATOR LIGHTS.

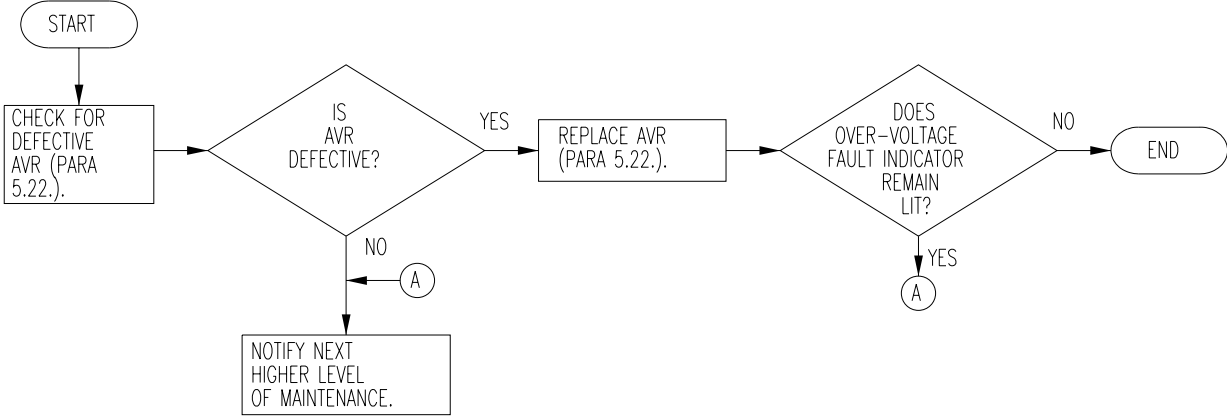

Section III. DIRECT SUPPORT MAINTENANCE PROCEDURES

5.6. AUXILIARY POWER UNIT.

Refer to appropriate system TM manual for APU removal and replacement procedures.

5.7. OIL PAN COVER.

This task covers: Replace

INITIAL SETUP

Tools

General Mechanic's Tool Kit
(Item 1, Appendix B)

Materials/Parts

Oil Pan Cover

Safety Wire
(Item 16, Appendix F)

Equipment Condition

Vehicle engine off.

MASTER ON-OFF switch on APU control unit set to OFF.

APU stopped and allowed to cool for ten minutes.

WARNING

Do not attempt to work on hot engine. Failure to heed this warning could result in injury to personnel or damage to equipment.

WARNING

Bolts securing engine to engine mount support the weight of the engine. Do not remove screws. Failure to heed this warning could result in injury to personnel or damage to equipment.

REPLACE

- a. Loosen, but do not remove, one bolt (1, Figure 5-1) securing safety wire (4), engine block (6), and engine mount (5).
- b. Unwrap safety wire (4) securing oil pan cover (3) to engine mount (5).
- c. Re-tighten bolt (1).
- d. Repeat steps a through c for remaining safety wires.
- e. Remove oil pan cover (3) from oil pan (2).
- f. Place new oil pan cover (3) on oil pan (2).
- g. Loosen, but do not remove, one bolt (1) securing engine block (6) and engine mount (5).
- h. Secure oil pan cover (3) by attaching safety wire (4) to hook on oil pan cover (3) and bolt (1).
- i. Tighten bolt (1).
- j. Repeat steps g through i for remaining safety wires.

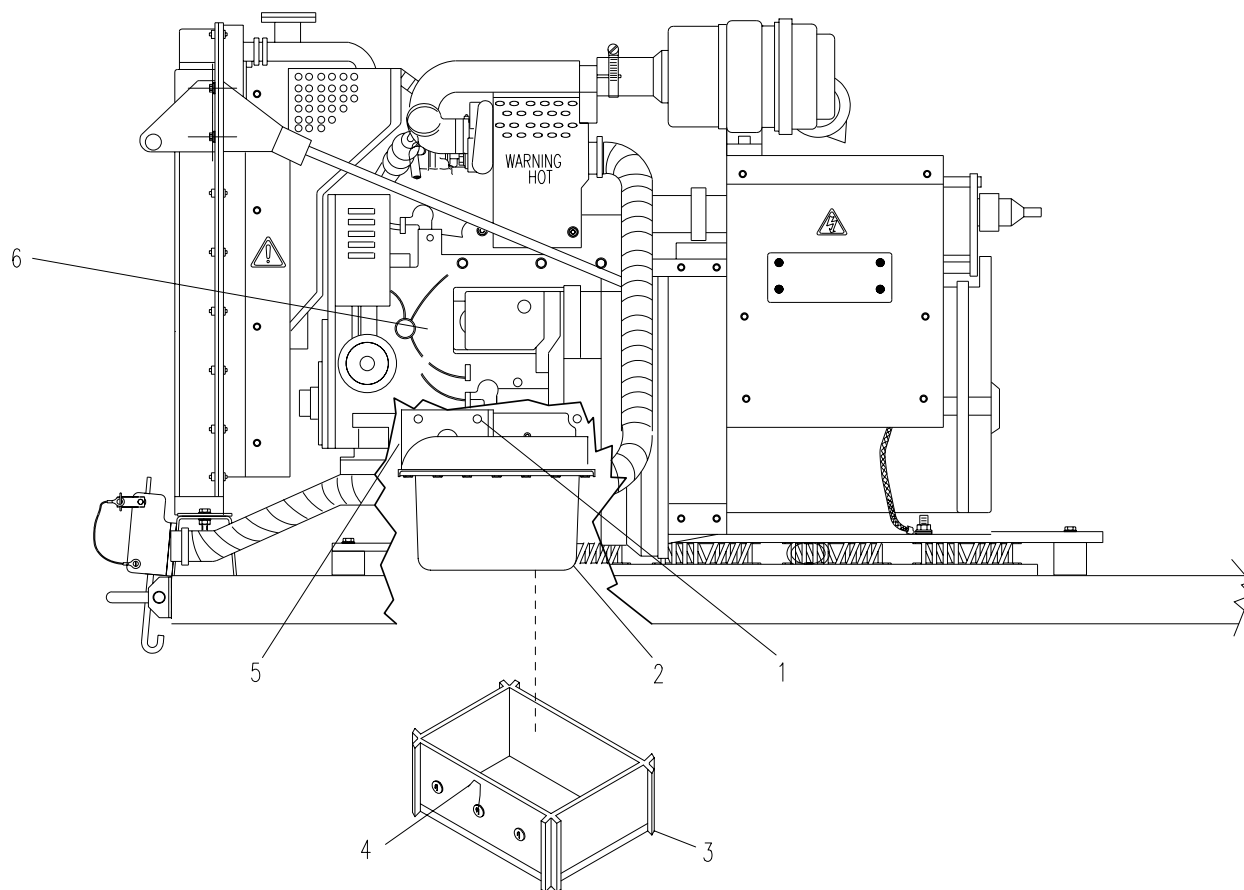

(MEP-903C, WIN-T)

Figure 5-1. Oil Pan Cover

5.8. OIL PAN.

This task covers: Replace

INITIAL SETUP

Tools

General Mechanic's Tool Kit
(Item 1, Appendix B)

Torque Wrench
(Item 2, Appendix B)

Materials/Parts

Oil Pan

Oil Pan Gasket
(Item 19, Appendix J)

Sealing Compound
(Item 17, Appendix F)

Equipment Condition

Engine stopped and allowed to cool completely.

MASTER ON-OFF switch on control box set to OFF.

Oil pan cover removed (para 5.7.).

Oil drained (para 4.14.).

REPLACE

- a. Remove eighteen bolts (1, Figure 5-2) securing oil pan (2) to engine block.
- b. Remove oil pan (2).
- c. Clean the pan and mounting surfaces.
- d. Apply sealing compound to oil pan as shown in Figure 5-2.
- e. Install gasket on oil pan.
- f. Secure oil pan (2) to engine block using eighteen bolts (1) and torque bolts between 13.0 and 15.2 ft-lbs (17.7 and 20.6 Nm) being careful to torque bolts sequentially in pattern as shown.

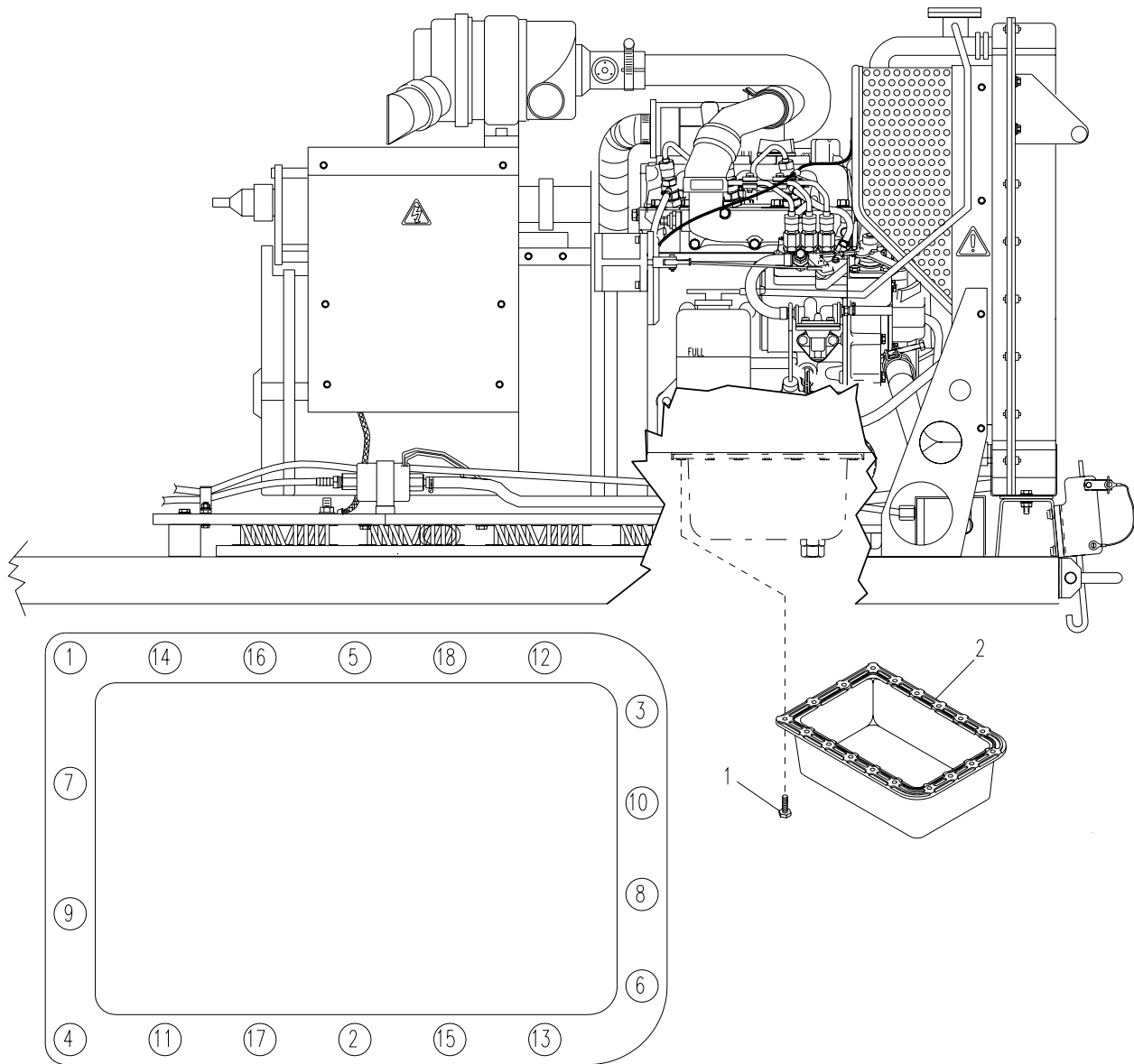

(MEP-903C, WIN-T)

Figure 5-2. Oil Pan

5.9. OIL PAN STRAINER.

This task covers: Replace

INITIAL SETUP

Tools

General Mechanic's Tool Kit
(Item 1, Appendix B)

Torque Wrench
(Item 2, Appendix B)

Equipment Condition

Engine stopped and allowed to cool completely.

MASTER ON-OFF switch on APU control unit set to OFF.

Oil pan removed (para 5.8.).

Materials/Parts

Oil Pan Strainer

Preformed Packing
(Item 20, Appendix J)

REPLACE

CAUTION

Do not switch bolts (2 and 6). Install bolts (2 and 6) into their original positions.

- a. Remove and tag two bolts (2 and 6, Figure 5-3) securing oil pan strainer (1) to engine block.
- b. Remove oil pan strainer (1) and preformed gasket (5).
- c. Install new oil pan strainer (1) and new preformed gasket (5).
- d. Secure bolt (2) in mounting hole marked "3" (4) and torque between 13.0 and 15.2 ft-lbs (17.7 and 20.6 Nm).
- e. Secure bolt (6) in mounting hole marked "2" (3) and torque between 13.0 and 15.2 ft-lbs (17.7 and 20.6 Nm).

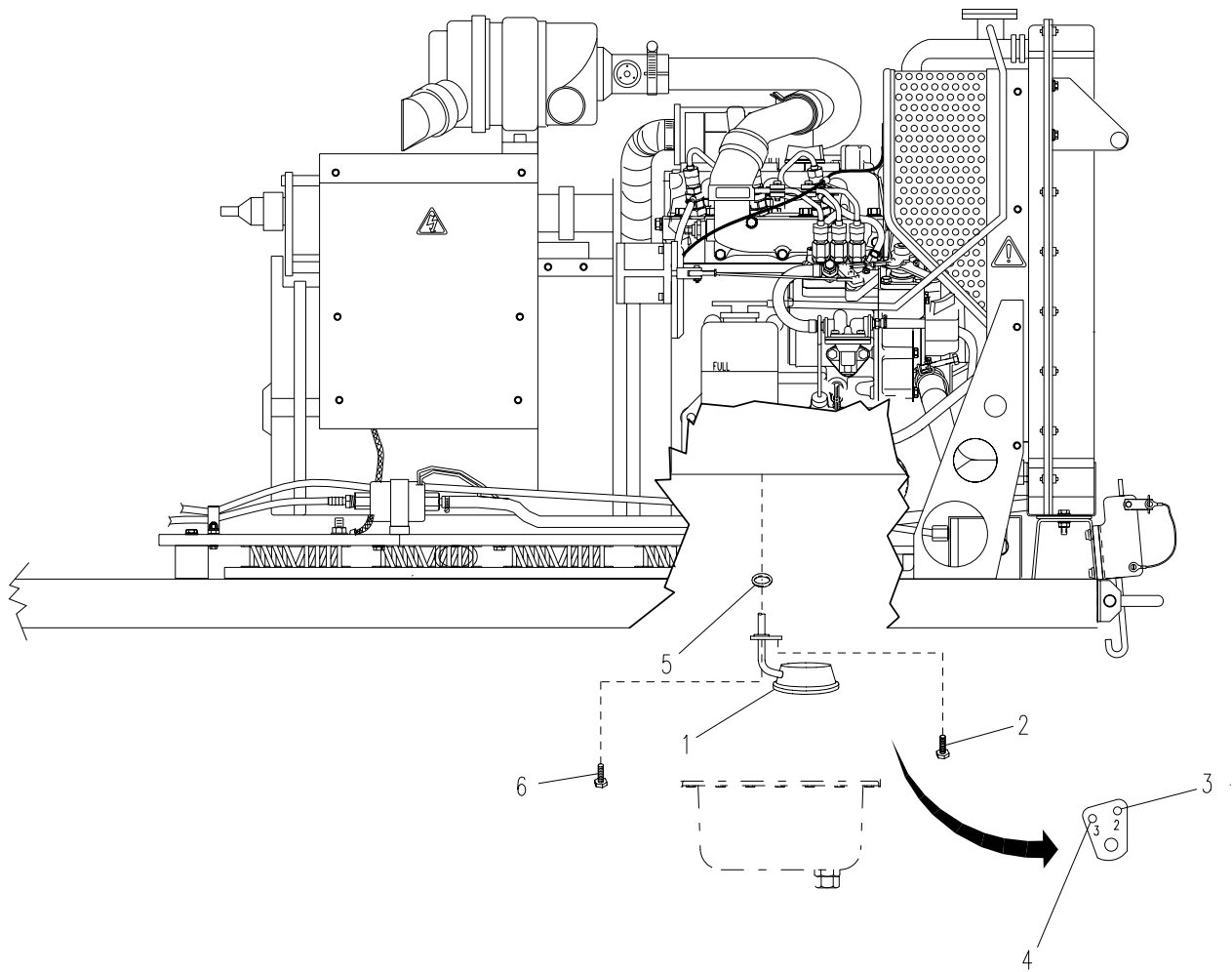

(MEP-903C, WIN-T)

Figure 5-3. Oil Pan Strainer

5.10. RELIEF VALVE.

This task covers: a. Inspect b. Replace

INITIAL SETUP

Tools

General Mechanic's Tool Kit
(Item 1, Appendix B)

Materials/Parts

Relief Valve

Equipment Conditions

Engine stopped and allowed to cool completely.

MASTER ON-OFF switch on APU controller set to OFF.

Oil filter removed (para 4.15.).

Oil cooler removed (para 4.16.).

INSPECT

Visually inspect valve seat (3), ball (2), and spring (1) for serviceability.

REPLACE

- a. Remove valve seat (3, Figure 5-4), ball (2), and spring (1) from engine block (4).
- b. Install new spring (1), ball (2), and valve seat (3) in engine block (4).

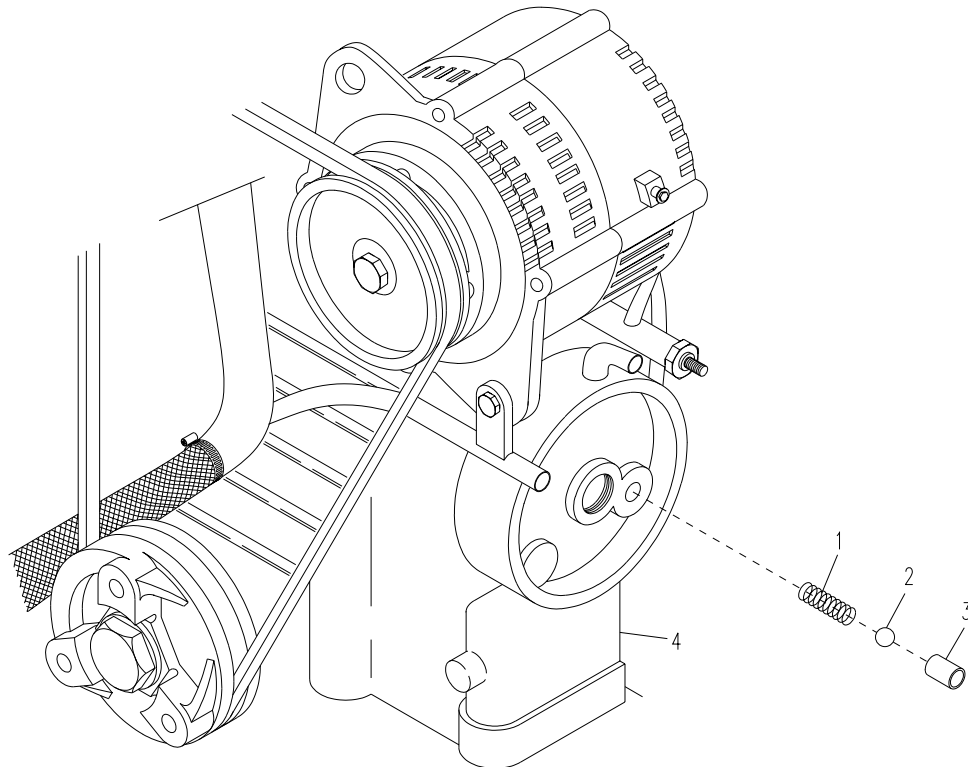

Figure 5-4. Relief Valve

5.11. RADIATOR CAP.

This task covers: Test

INITIAL SETUP

Tools

Radiator Tester
(Item 7, Appendix B)

Equipment Conditions

MASTER ON-OFF switch set to OFF.

Radiator cap removed (para 3.7.).

Materials/Parts

Radiator Cap

WARNING

Hot coolant is under pressure. Do not remove radiator cap when engine is hot. Allow engine to cool completely before removing radiator cap. ~~Once cooling has occurred, loosen cap slightly to~~ relieve any excess pressure before removing the cap. Failure to observe this warning could result in burns or injury to personnel.

TEST

- a. Connect radiator tester (2, Figure 5-5) to radiator cap (1).
- b. Apply a pressure of 13 psi (89.63 kPa) and measure the time for pressure to fall to 9 psi (62.05 kPa).
- c. If time is less than 10 seconds, replace radiator cap (1) (para 3.7.).

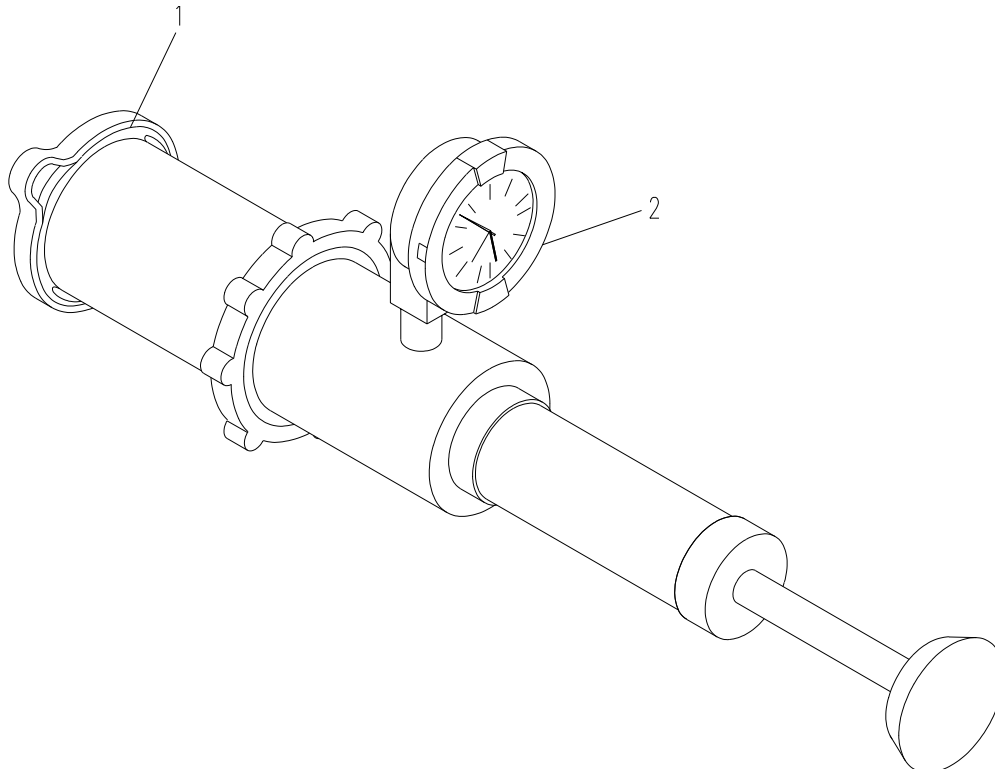

Figure 5-5. Radiator Cap

5.12. WATER PUMP.

This task covers: Replace

INITIAL SETUP

Tools

General Mechanic's Tool Kit
Item 1, Appendix B)

Materials/Parts

Water Pump

Water Pump Gasket
(Item 12, Appendix J)

Sealing Compound 88-20595-2
(Item 18, Appendix F)

Equipment Conditions

Engine stopped and allowed to cool completely.

MASTER ON-OFF switch on APU controller set to OFF.

Coolant drained (para 4.19.).

Fan belt removed (para 4.23.)

REPLACE

NOTE

Note size and position of all bolts during removal of water pump.

- a. Loosen two clamps (8) securing lower hose (9) to water pump (3) and remove lower hose (9).
- b. Loosen two clamps (4) securing upper hose (5) to water pump (3) and water flanges (10) and remove upper hose (5).
- c. Remove seven bolts (11 and 12), gasket (6), and water pump (3) from engine block (7).
- d. Remove four bolts and lock washers and flat washers (1, Figure 5-6) securing fan (2) to water pump (3) and remove fan (2).
- e. Thoroughly clean mounting surfaces of engine block.
- f. Apply sealing compound to both sides of new gasket (6).
- g. Install fan (2) and secure with four lock washers and flat washers and bolts (1).

NOTE

Four short screws must be placed in water pump holes prior to installation.

- h. Install new gasket (6) and pump (3) on engine (7) and secure with seven bolts (11 and 12).
- i. Install upper hose (5) and secure with two clamps (4).
- j. Install lower hose (9) and tighten two clamps (8).

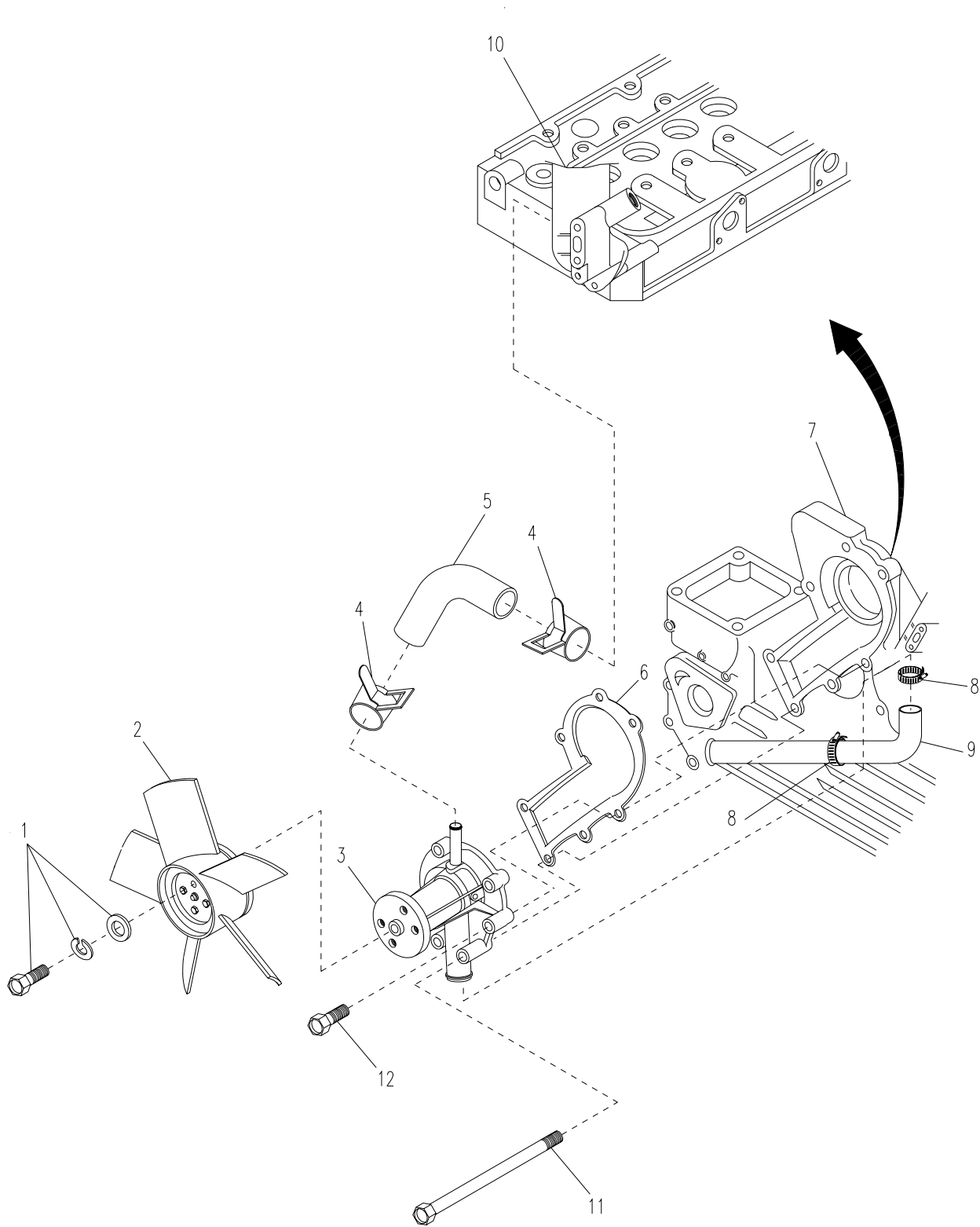

Figure 5-6. Water Pump

5.13. INJECTION NOZZLE ASSEMBLY.

This Task Covers: a. Test b. Replace

INITIAL SETUP

Tools

General Mechanic's Tool Kit
(Item 1, Appendix B)

Injection Pump Pressure Tester
(Item 19, Appendix B)

Gloves, Chemical and Oil Protective
Goggles, Rubber Apron, and Mask
(Item 34, Appendix B)

Suitable Container for Fuel

Materials/Parts

Injection Nozzle Assembly

Injection Nozzle Washer Gasket
(Item 21, Appendix J)

Equipment Conditions

Engine off and allowed to cool for thirty minutes.

MASTER ON-OFF switch on APU control unit set to OFF.

Injection lines removed (para 4.35., steps h, i, j).

WARNING

Ensure that NO IGNITION SOURCE is within 50 feet of the 10 kW APU. The fuel in this APU is highly flammable. Do not smoke. Do not splash fuel on hot components. Failure to observe this warning could result in severe injury to personnel or DEATH.

WARNING

Avoid fuel contact with skin. Wear protective gloves, goggles, apron, and mask. Failure to observe this warning could result in severe injury to personnel or DEATH.

TEST

- a. Remove injection nozzle assembly (perform steps a, b, and c of REPLACE).
- b. Test nozzle spraying condition.

WARNING

Always point fuel spray away from direction of personnel. Contact with the fuel spray could cause blood poisoning and cell damage. Always aim spray into a suitable container. Failure to observe this warning could result in severe injury to personnel or DEATH.

- (1) Install injection nozzle (1, Figure 5-7 (sheet 1)) to injection pump pressure tester (2).
- (2) Pump the tester handle until fuel fully sprays out from the nozzle.
- (3) Observe the spray (3). If uneven or defective, replace the nozzle.

c. Test valve seat tightness.

- (1) With injection nozzle (1) installed to the nozzle tester (2), pump handle until pressure is raised to 1849 psi (12.75 MPa) and sustain pressure for 10 seconds.
- (2) Observe injection nozzle (1) for fuel leaks. If leaks are observed, replace injection nozzle.

d. Test Fuel Injection Pressure.

- (1) With injection nozzle (1) installed to the nozzle tester (2), slowly move the tester handle and measure the pressure at which the nozzle begins to spray fuel.
- (2) If pressure is not between 1991 and 2133 psi (13.72 to 14.70 MPa) and/or the nozzle leaks, replace the injection nozzle.

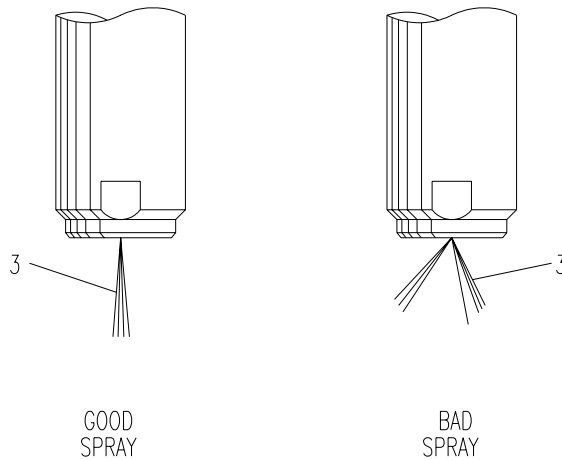
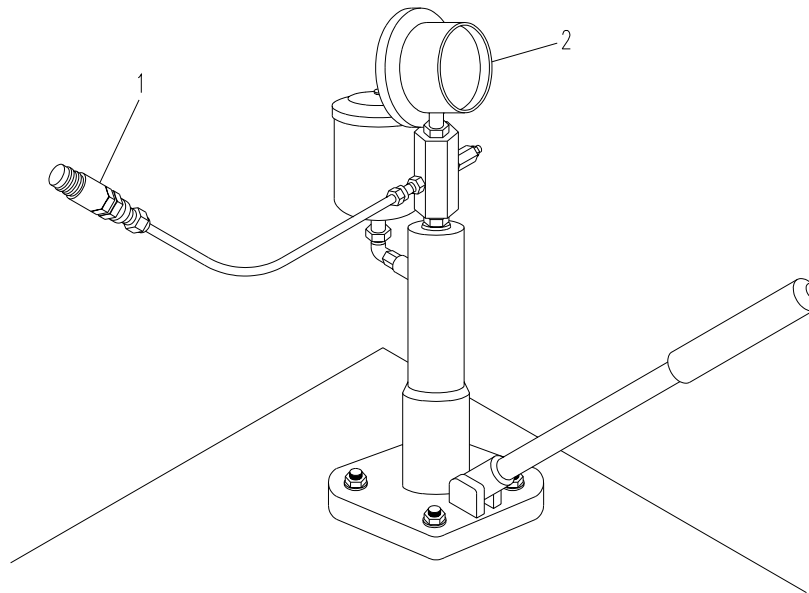

Figure 5-7. Injection Nozzles (Sheet 1 of 2)

REPLACE

WARNING

Compressed air shall not be used for cleaning purposes except where reduced to less than 29 pounds per square inch gauge (psig) (199.94 kPa), and then only with effective chip guarding and personnel protective equipment. Compressed air is dangerous and can cause serious bodily harm if protective means or methods are not observed to prevent chip or particle (of whatever size) from being blown into the eyes or unprotected skin of the operator or other personnel.

- a. Thoroughly clean area around injection nozzles with compressed air prior to removal of injection nozzles.
- b. Remove three nuts (4, sheet 2) and remove fuel overflow pipe (5) and three sealing washers (6).
- c. Unscrew and remove three injection nozzle assemblies (1) and washer gasket (7).
- d. Install new injection nozzle assemblies and washer gaskets (7). Torque between 36.2 and 50.6 ft-lbs (49 and 68.6 Nm).
- e. Install three sealing washers (6) and injection overflow pipe (5), and secure with three nuts (4).

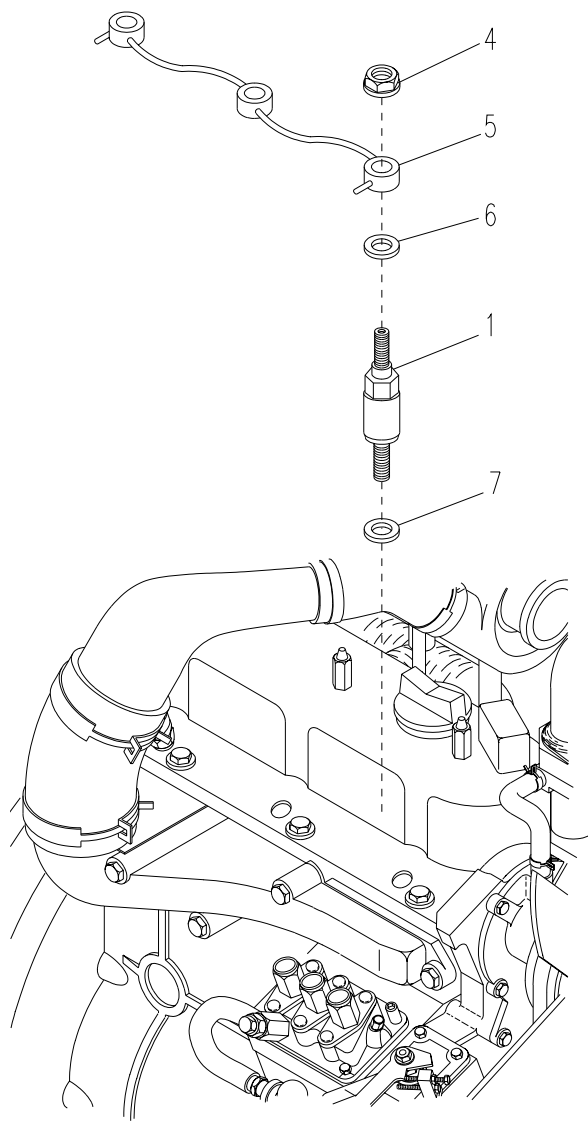

Figure 5-7. Injection Nozzles (Sheet 2)

5.14. INJECTION PUMP.

This task covers: a. Test b. Adjust c. Replace

INITIAL SETUP

Tools

General Mechanic's Tool Kit
(Item 1, Appendix B)

Injection Pump Pressure Tester
(Item 19, Appendix B)

Gloves, Chemical and Oil Protective
Goggles, Rubber Apron, and Mask
(Item 19, Appendix B)

Fuel Supply Bottle

Materials/Parts

Shims
Injection Pump

Sealing Compound
(Item 18, Appendix F)

Equipment Conditions

Engine stopped and allowed to cool completely.

MASTER ON-OFF switch on APU control unit set to OFF.

Fuel lines and fittings removed (para 4.35.).

WARNING

Ensure that NO IGNITION SOURCE is within 50 feet of the 10 kW APU. The fuel in this APU is highly flammable. Do not smoke. Do not splash fuel on hot components. Failure to observe this warning could result in serious injuries to personnel or DEATH.

WARNING

Avoid fuel contact with skin. Wear protective gloves, goggles, apron, and mask. Failure to observe this warning could result in serious injuries to personnel or DEATH.

TEST

- a. Loosen clamp (2, Figure 5-8) and remove hose (1) from injection pump (3).
- b. Loosen one clamp (4) on fuel pipe between injection pump (3) and nozzle (7).
- c. Loosen two nuts (5) securing fuel pipe (6) between injection pump (3) and nozzle (7) and remove fuel pipe (6).
- d. Install pressure tester (11) on injection pump (3).
- e. Install fuel supply bottle (10) to injection pump (3) where hose (1) was disconnected in step a.
- f. Set speed control lever (12) to the maximum fuel discharge position.
- g. Turn the engine cw by turning the nut on the crankshaft pulley with a socket and wrench to

raise fuel pressure.

- h. Observe fuel pressure. If fuel pressure does not reach 2133 psi (14.71 MPa), replace injector pump.
- i. If fuel pressure reaches 2133 psi (14.71 MPa), measure the length of time it takes to drop to 1991 psi (140 13.73 MPa). If pressure drops to 1991 psi (13.73 MPa) in less than 5 seconds, replace the injector pump.
- j. Repeat steps c. through i. for fuel injection pump outlets to fuel pipes (13) and (14).

ADJUST

NOTE

Use this procedure to adjust injection pump timing. Injection pump timing may be required when blue or black exhaust smoke is observed, low engine power, or engine will not start.

- a. Remove 10 kW alternator from APU (para 5.24.).
- b. Remove fuel line from injection pump (3) (para 4.35.).
- c. Install a fuel supply to the injection pump (3).
- d. Set speed control lever to maximum fuel discharge position.
- e. Turn flywheel (19) by turning retaining nut on crankshaft pulley until fuel fills up to the hole of the delivery valve holder (14).
- f. Continue to turn flywheel (19) until fuel overflows. Stop turning.
- g. Observe timing mark on (20) flywheel (19). If it does not line up with timing hole (21) in bell housing, remove injection pump (3) and remove or install injection pump shims (17) until marks line up.

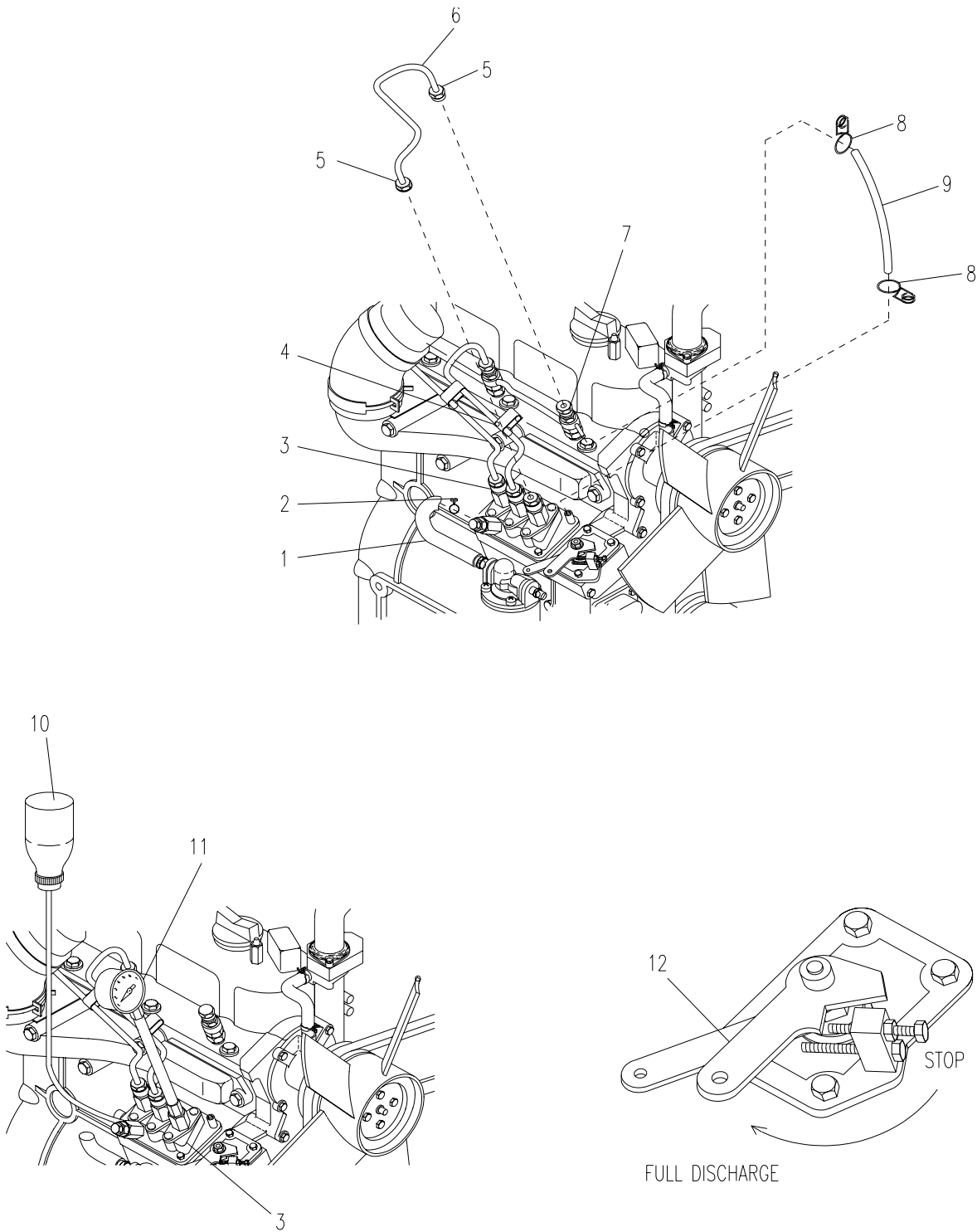

Figure 5-8. Injection Pump (Sheet 1 of 3)

REPLACE

WARNING

Compressed air shall not be used for cleaning purposes except where reduced to less than 29 pounds per square inch gauge (psig) (199.94 kPa) and then only with effective chip guarding and personnel protective equipment. Compressed air is dangerous and can cause serious bodily harm if protective means or methods are not observed to prevent chip or particle (of whatever size) from being blown into the eyes or unprotected skin of the operator or other personnel.

- a. Close the valve on fuel filter.
- b. Thoroughly clean injection pump area with compressed air.
- c. Remove one socket head screw (12a, Figure 5-8, sheet 1), nut (12b), and lock washer (12c) securing rod end bearing (12a) of long actuator linkage rod (12e) to pivot arm (12f) and remove rod end bearing (12d).
- d. Loosen one clamp (8, Figure 5-8) and disconnect overflow hose located at fuel injection pump (3).
- e. Loosen two clamps (4), six nuts (5), and remove three fuel pipes (6).
- f. Loosen one clamp (2) and remove fuel line (1).
- g. Remove one screw and lock washer (13) and remove actuator pivot support bracket (16).

NOTE

Make sure actuator pivot support bracket (16) does not spin and retains original position.

- h. Remove three socket head bolts and lock washers (15).
- i. Lift injection pump (3) and shims (17) out of engine block. Thoroughly clean old sealing compound from shims (17) and surface of engine block (18).
- j. Apply sealing compound to shims (17) and new injection pump (3).
- k. Install new shims (17) and injection pump (3) ensuring that the fuel rack arm on injection pump aligns with the slot on the governor fork assembly (missing illus. ref.) on engine block (18).

- l. Install three socket head bolts and lock washers (15).
- m. Install actuator pivot support bracket (16) and secure with lock washer and bolt (13).
- n. Install three fuel lines (6) and secure with six nuts (5) and two clamps (4).
- o. Connect overflow hose (9) to injection pump (3) and secure with one clamp (8).
- p. Install fuel line (1) from fuel feeder pump and secure with one clamp (2).

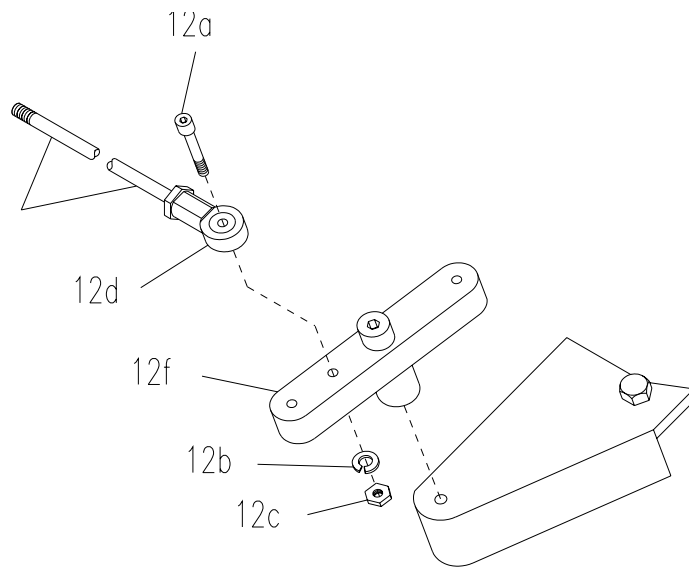

Figure 5-8. Injection Pump (Sheet 2)

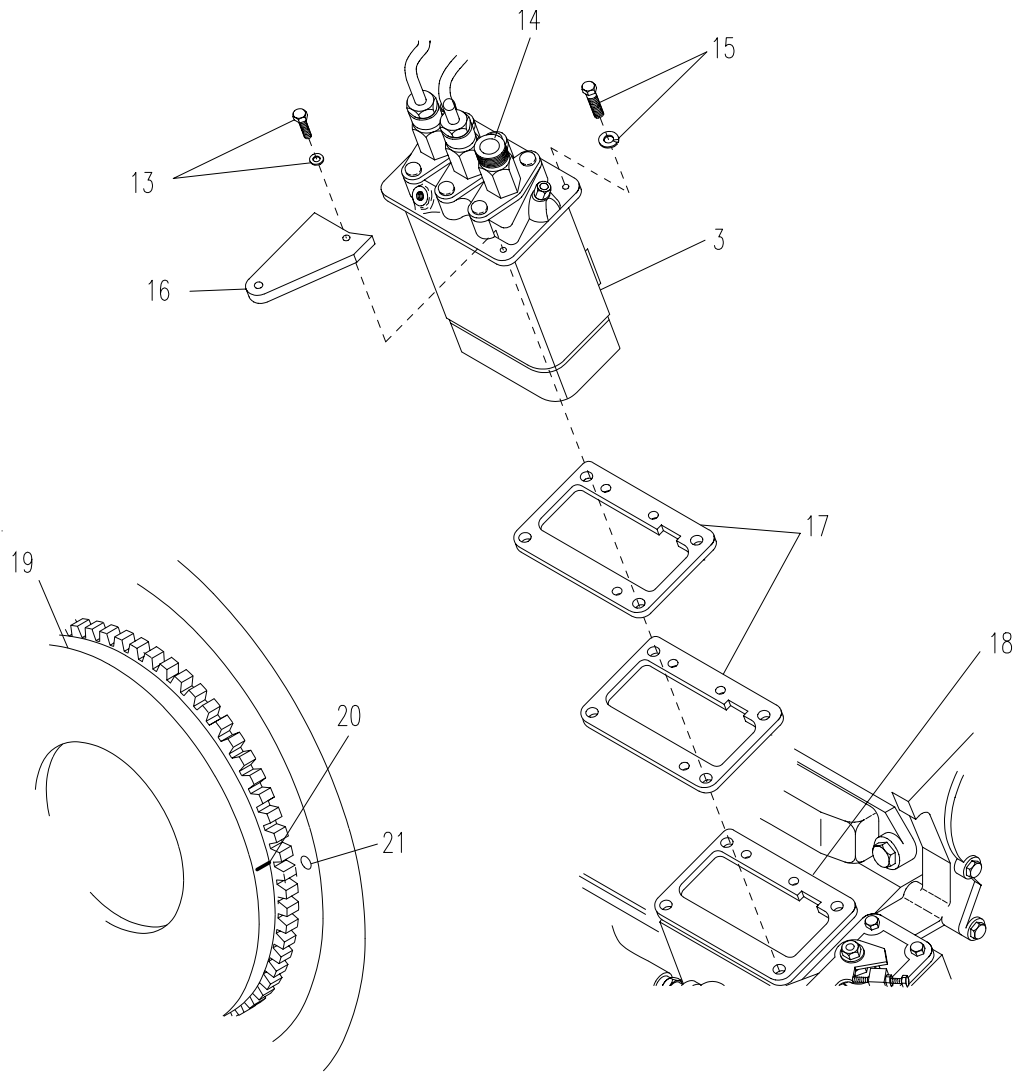

Figure 5-8. Injection Pump (Sheet 3)

5.15. CURRENT TRANSFORMER.

This task covers: Replace

INITIAL SETUP

Tools

General Mechanic's Tool Kit
(Item 1, Appendix B)

Materials/Parts

Current Transformer

Equipment Conditions

MASTER ON-OFF switch on APU control unit set to OFF.

Contacting mounting plate removed (para 4.52.).

WARNING

Ensure that APU DC power supply is disconnected. Failure to observe this warning could result in severe injury or DEATH to personnel.

WARNING

Ensure that the APU is turned off and completely de-energized before opening generator housing. Failure to observe this warning could result in severe injury or DEATH to personnel.

REPLACE

- a. Remove four nuts with captive washers (1, Figure 5-9) and four screws (JTACS and WIN-T), or slotted hex-head bolts (JTACS and WIN-T) (3) and remove current transformer (2) from contacting mounting plate (4).
- b. Install current transformer (2) to contacting mounting plate (4) and secure with four nuts with captive washers (1) and bolts (3).

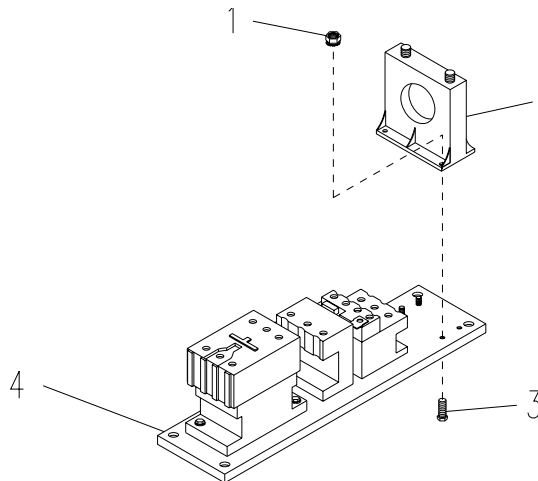

Figure 5-9. Current Transformer

5.16. OVERLOAD RELAY.

This task covers: a. Test b. Adjust c. Replace

INITIAL SETUP

Tools

General Mechanic's Tool Kit
(Item 1, Appendix B)

Shop Equipment, Electrical Repair,
Semitrailer Mounted
(Item 3, Appendix B)

WARNING

Ensure that APU DC power supply is disconnected. Failure to observe this warning could result in severe injury or DEATH to personnel.

Materials/Parts

Overload Relay
(See Figure FO-1)

WARNING

Ensure that the APU is turned off and completely de-energized before opening generator housing. Failure to observe this warning could result in severe injury or DEATH to personnel.

Equipment Conditions

MASTER ON-OFF switch on APU control unit set to OFF.

Contactor mounting plate removed (para 4.52.).

TEST

- a. Refer to Figure FO-1 (SICPS/WIN-T) or F0-7 (JTACS) and check for continuity between L1 and T1, L2 and T2, and L3 and T3.
- b. Using a Multi-meter, test for continuity between connections NC 95 and NC 96 on overload relay.
- c. Press TEST button on overload relay. Continuity should be broken.
- d. Press RESET button on overload relay. Continuity should return.
- e. If any pair of contacts fails the continuity test, the overload relay is defective. Replace overload relay.
- f. If continuity is not broken between NC 95 and NC 96, replace overload relay.

ADJUST

Adjust current limiting dial to 50 amps.

REPLACE

- a. Tag and remove electrical leads from terminals L1, L2, and L3 of overload relay (2, Figure 5-10) by loosening three screws.
- b. Remove two nuts with captive washers (1) and two bolts (4) and remove overload relay (2) from contactor mounting plate (3).
- c. Install overload relay (2) on contactor mounting plate (3) and secure with two bolts (4) and nuts with captive washers (1).
- d. Reconnect electrical leads to terminals L1, L2, and L3 of overload relay (2) and secure with three screws.

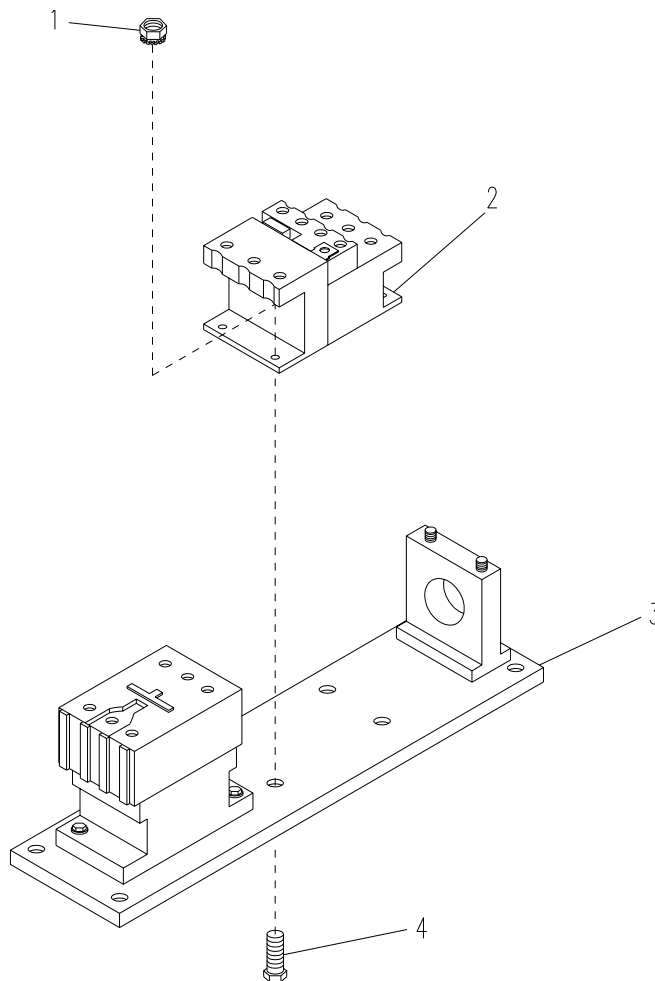

Figure 5-10. Overload Relay

5.17. CONTACTOR PLATE.

This task covers: Replace

INITIAL SETUP

Tools

General Mechanic's Tool Kit
(Item 1, Appendix B)

Equipment Conditions

APU DC Box Wiring Harness J3 removed (para 5.26.).

Wiring Harness J1 removed (para 5.28.).

Materials/Parts

Contactor Plate

Contactor Mounting Plate removed (para 4.52.).

Electrical Output Terminal Board removed (para 4.51.).

REPLACE

- a. Remove ten screws, or slotted hex-head bolts, lock washers and washers (SICPS) (4, Figure 5-11) securing contactor plate (2) to generator housing (3).
- b. Remove four bolts and lock washers (1) securing contactor plate (2) to generator (5). Remove contactor plate (2).
- c. Install contactor plate (2) on generator (5) using four bolts and lock washers (1).
- d. Secure contactor plate (2) to generator housing with ten screws, or slotted hex-head bolts, lock washers and washers (SICPS) (4).

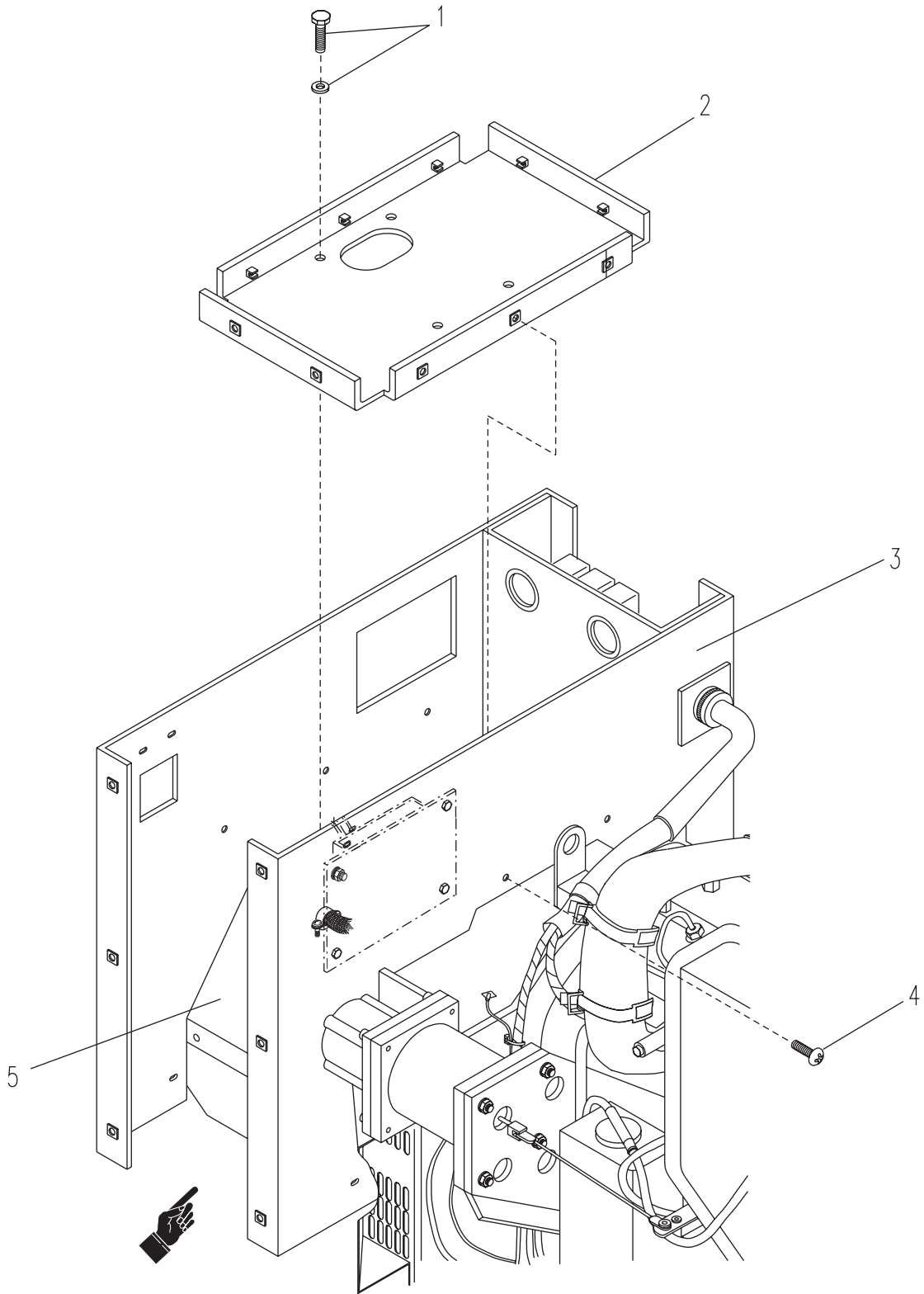

Figure 5-11. Contactor Plate

5.18. RELAY BOARD.

This task covers: a. Inspect b. Replace

INITIAL SETUP

Tools

General Mechanic's Tool Kit
(Item 1, Appendix B)

Materials/Parts

Relay Board
10 Amp Fuse
5 Amp Fuse (2)

Equipment Conditions

MASTER ON-OFF switch on APU control unit set
severe to OFF.

Air filter removed (para 4.45.).

WARNING

Ensure that APU DC power supply is disconnected.
Failure to observe this warning could result in severe
injury or DEATH to personnel.

WARNING

Ensure that the APU is turned off and completely de
energized before opening generator housing.
Failure to observe this warning could result in

injury or DEATH to personnel.

INSPECT

- a. Remove four screws (JTACS), or slotted hex-head bolts (SICPS and WIN-T), flat and lock washers (1, Figure 5-12) and remove generator housing top cover (2).
- b. Remove four screws (JTACS), or slotted hex-head bolts (SICPS and WIN-T), flat and lock washers (5) and generator housing side cover (4).
- c. Inspect fuses F1, F2, and F3 (7) on relay board (6).
- d. Replace blown fuses (7).

REPLACE

- a. Remove four screws (JTACS), or slotted hex-head bolts (SICPS and WIN-T), flat and lock washers (1), and generator housing top cover (2).
- b. Remove four screws (JTACS), or slotted hex-head bolts (SICPS and WIN-T), flat and lock washers (5), and generator housing side cover (4).
- c. Refer to foldout F0-1 (SICPS/WIN-T) or F0-7 (JTACS) and tag and remove electrical leads from relay board (6).
- d. Remove six nuts with captive washers (8) (JTACS) securing relay board (6) to vibration mounts (3), or six screws, flat washers, lock washers, vibration mounts, and hex nuts (SICPS and WINT) and remove relay board (6).

- e. Install relay board (6) on vibration mounts (3) and secure with six nuts with captive washers (8) (JTACS), or six screws, flat washers, lock washers, vibration mounts and hex nuts (SICPS and WIN-T).
- f. Reconnect electrical leads to relay board (6). Remove tags.
- g. Install generator housing side cover (4) and secure with four screws (JTACS), or slotted hexhead bolts (SICPS and WIN-T), flat and lock washers (5).
- h. Install generator housing top cover (2) and secure with four screws (JTACS), or slotted hexhead bolts (SICPS and WIN-T), flat and lock washers (1).

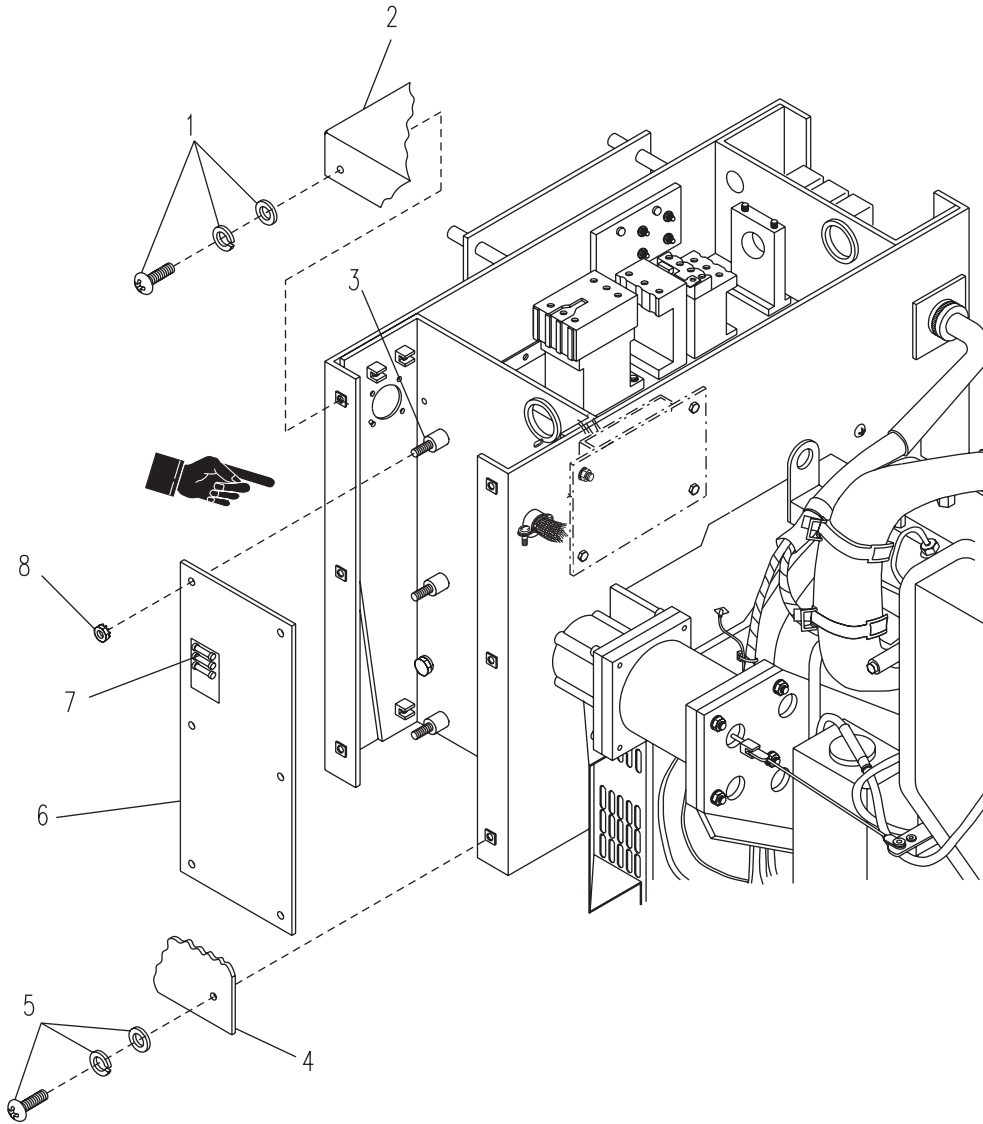

Figure 5-12. Relay Board

5.19. DC BOX SUBASSEMBLY.

This task covers: Replace

INITIAL SETUP

Tools

General Mechanic's Tool Kit

set
(Item 1, Appendix B)

Equipment Conditions

MASTER ON-OFF switch on APU control unit

to OFF.

Materials/Parts

5.26.).

APU DC box wiring harness J3 removed (para

DC Box Subassembly

Relay board removed from APU (para 5.18.).

REPLACE

- a. Remove six screws (JTACS and WIN-T), or seven screws (SICPS), flat and lock washers (3, Figure 5-13) securing DC box (1) to generator housing (4).
- b. Remove two bolts (7) (JTACS) and lock washes (6), or three bolts (SICPS and WIN-T), flat and lock washers securing DC box (1) to generator (5) and remove DC box (1).
- c. Remove six nuts with captive washers (2), six studs (8), vibration mounts (9), and washers (10) from DC box (1).
- d. Install six washers (10), vibration mounts (9), and studs (8) on DC box (1) and secure with six nuts with captive washers (2).
- e. Align holes and secure DC box (1) to generator (5) with two bolts (7) (JTACS) and lock washers (6), or three bolts (SICPS and WIN-T), flat and lock washers.
- f. Secure DC box (1) to generator housing (4) with six screws (JTACS and WIN-T), or seven screws (SICPS), flat and lock washers (3).

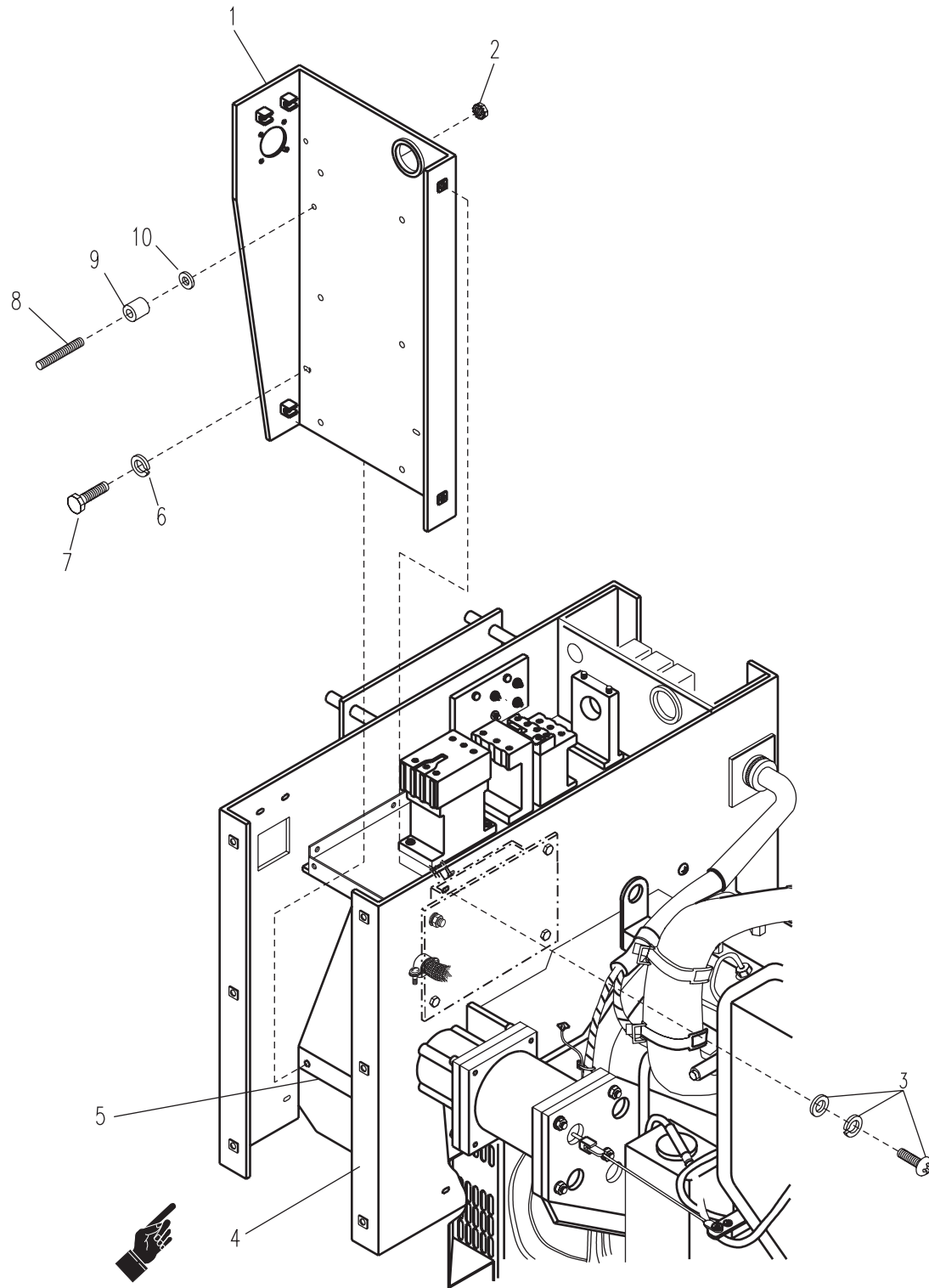

Figure 5-13. DC Box Subassembly

5.20. ELECTROMAGNETIC SAFETY RELAYS.

This task covers: a. Test b. Replace

INITIAL SETUP

Tools

General Mechanic's Tool Kit
(Item 1, Appendix B)

Ohm Meter

Materials/Parts

Safety Relay

Equipment Conditions

MASTER ON-OFF switch on APU control unit set to OFF.

Air filter removed (para 4.45.).

WARNING

Ensure that APU DC power supply is disconnected. Failure to observe this warning could result in severe injury or DEATH to personnel.

WARNING

Ensure that the APU is turned off and completely de-energized before opening generator housing. Failure to observe this warning could result in severe injury or DEATH to personnel.

TEST

- a. Perform steps a through c of REPLACE below.
- b. Check for resistance between contacts 85 and 86, and 30 and 87a. Resistance should be 260 ohms +/- 10.
- c. Check for an open circuit between 30 and 87.
- d. Apply 24 voltages DC to terminals 86 and 87 with the positive voltage applied to 86.
- e. Check for continuity between contacts 30 and 87 and check for open circuit between contacts 30 and 87a.
- f. Remove 24 volts DC from contacts 85 and 86.
- g. Replace electromagnetic safety relays if defective.
- h. Perform steps d through f of REPLACE below.
- i. Additional test procedures to be determined

REPLACE

- a. Remove four screws (JTACS), or slotted hex-head bolts (SICPS and WIN-T), flat and lock washers (4, Figure 5-14), and generator housing top cover (3).
- b. Remove two screws, wing nuts and lock washers (6a) (JTACS), or four slotted hex-head bolts (SICPS and WIN-T), flat and lock washers (6), and generator housing side cover (5) (muffler side).
- c. Remove electromagnetic safety relay (1) from relay socket (2).
- d. Install electromagnetic safety relay (1) into relay socket (2).
- e. Install generator housing side cover (5) and secure with two screws, wing nuts and lock washers (6a) (JTACS), or four slotted hex-head bolts (SICPS and WIN-T), flat and lock washers (6).
- f. Install generator housing top cover (3) and secure with four screws (JTACS), or slotted hex-head bolts (SICPS and WIN-T), flat and lock washers (4).

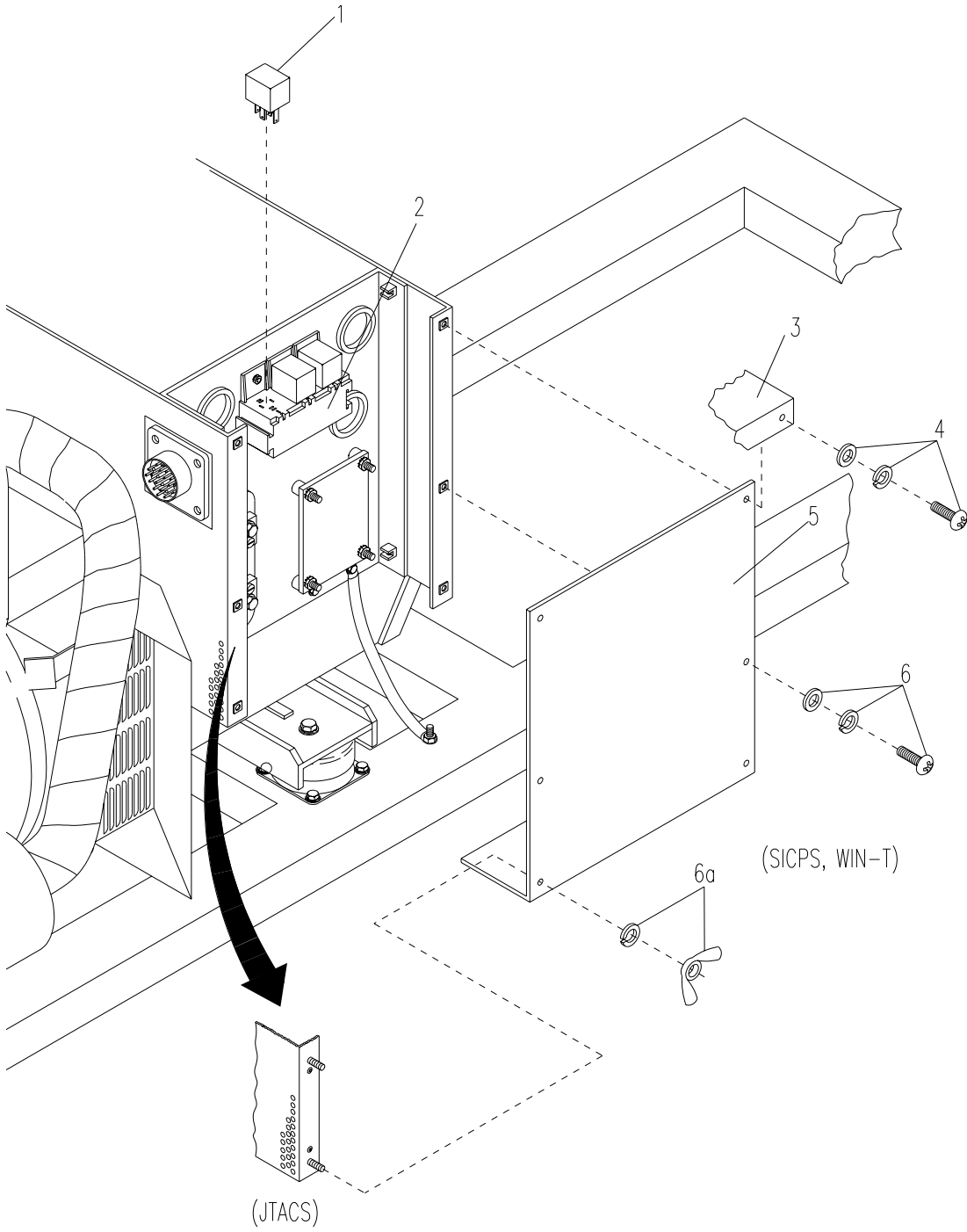

Figure 5-14. Electromagnetic Safety Relays

5.21. RELAY SOCKETS.

This task covers: Replace

INITIAL SETUP

Tools

General Mechanic's Tool Kit
(Item 1, Appendix B)

Equipment Conditions

MASTER ON-OFF switch on APU control unit set to OFF.

Electromagnetic safety relays removed (para 5.20.).

Materials/Parts

Relay Socket

WARNING

Ensure that APU DC power supply is disconnected. Failure to observe this warning could result in severe injury or DEATH to personnel.

WARNING

Ensure that the APU is turned off and completely de-energized before opening generator housing. Failure to observe this warning could result in severe injury or DEATH to personnel.

REPLACE

- a. Remove four screws (JTACS), or slotted hex-head bolts (SICPS and WIN-T), flat and lock washers (5, Figure 5-15), and remove generator housing top cover (4).
- b. Remove two screws, wing nuts and lock washers (7a) (JTACS), or four slotted hex-head bolts (SICPS and WIN-T), flat and lock washers (7), and generator housing side cover (6) (muffler side).
- c. Tag and remove electrical leads from relay sockets (2).
- d. Remove two screws (1), two nuts with captive washers (3), and remove relay sockets (2).
- e. Install relay sockets (2) and secure with two screws (1) and nuts with captive washers (3).
- f. Install electrical leads in relay sockets (2) and remove tags.
- g. Install generator housing side cover (6) and secure with two screws, wing nuts and lock washers (7a) (JTACS), or four slotted hex-head bolts (SICPS and WIN-T), flat and lock washers (7).
- h. Install generator housing top cover (4) and secure with four screws (JTACS), or slotted hex-head bolts (SICPS and WIN-T), flat and lock washers (5)

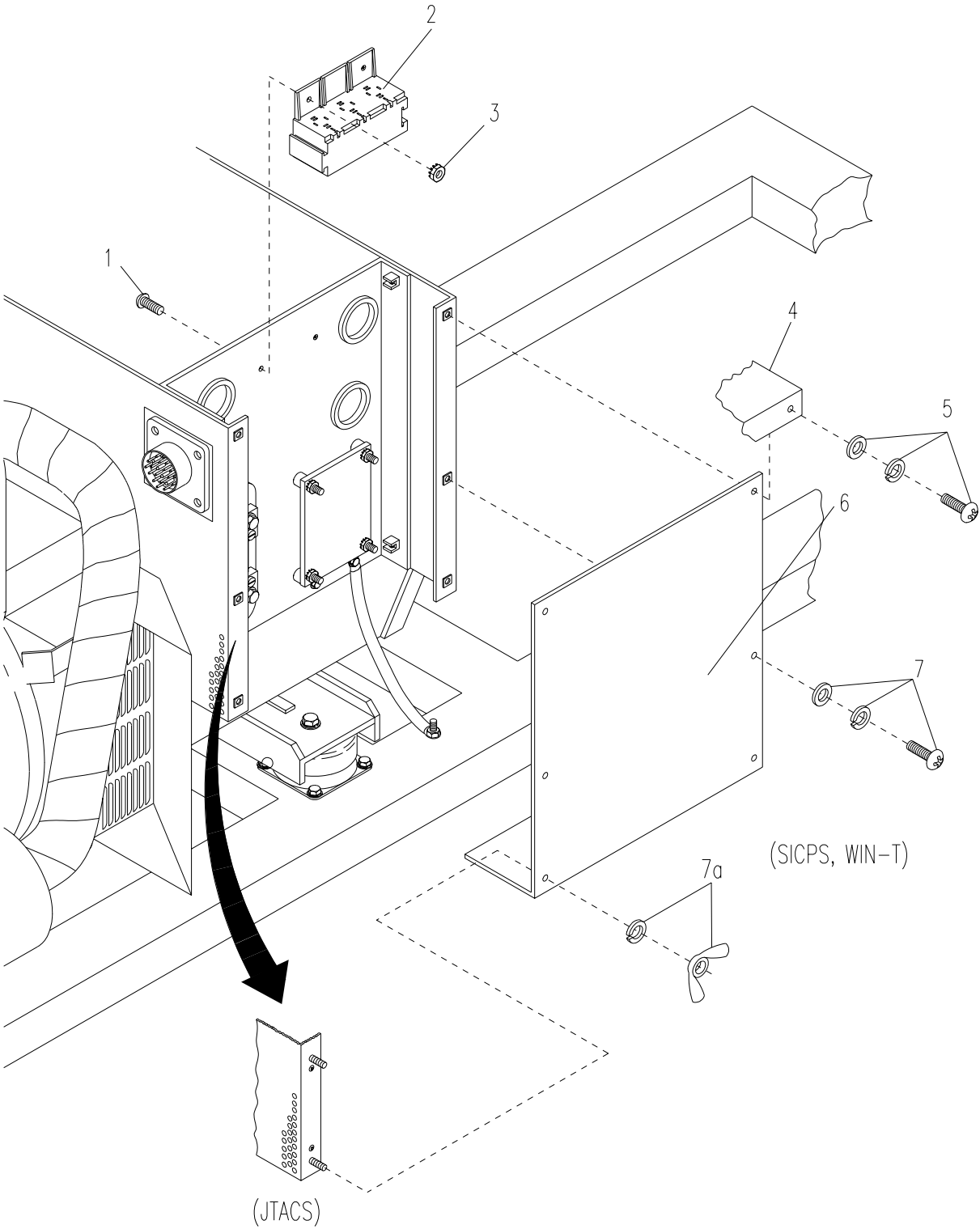

Figure 5-15. Relay Sockets

5.22. AUTOMATIC VOLTAGE REGULATOR.

This task covers: a. Test b. Replace

INITIAL SETUP

Tools

General Mechanic's Tool Kit
(Item 1, Appendix B)

Shop Equipment, Electrical, Repair, Semitrailer
Mounted
(Item 3, Appendix B)

240 VAC Isolating Transformer
(Item 23, Appendix B)

240 1I Transformer, Power, Autotransformer
(Item 24, Appendix B)

5 Amp Fuse
(Item 25, Appendix B)

2 Amp Fuse
(Item 26, Appendix B)

Neon Lamp
(Item 27, Appendix B)

Incandescent Lamp
(Item 4, Appendix B)

Materials/Parts

Automatic Voltage Regulator

Equipment Conditions

MASTER ON-OFF switch on APU control unit set to OFF.

Air filter removed (para 4.45.).

WARNING

Ensure that APU DC power supply is disconnected. Failure to observe this warning could result in severe injury or DEATH to personnel.

WARNING

Ensure that the APU is turned off and completely de-energized before opening generator housing. Failure to observe this warning could result in severe injury or DEATH to personnel.

TEST

- a. Remove automatic voltage regulator (AVR) (steps a through d of "REPLACE").
- b. Set up test procedure as shown in Figure 5-16 (sheet 1), but do not apply power.
- c. Turn AVR VOLTS and STABILITY controls fully ccw.
- d. Ensure the autotransformer is set to minimum volts position.
- e. Switch on power supply and check that neon lamp is lit.
- f. Slowly turn the variable autotransformer until 5 volts AC is across AVR terminals 7 and 8. Use a separate voltmeter if necessary.

- g. If ammeter reading is greater than 0.2 amp, AVR is faulty. Replace AVR. If not, continue.
- h. Measure voltage across AVR terminals X and XX. Voltage should be 1 volt DC or greater.
- i. Slowly turn the variable autotransformer up to 100 volts. The 100 W lamp should glow.
- j. Slowly turn the variable autotransformer up to 200 volts. The 100 W lamp should go out.
- k. Slowly turn the variable autotransformer down to 100 volts. The 100 W lamp should glow.
- l. Reinstall AVR (steps e through h of "REPLACE").

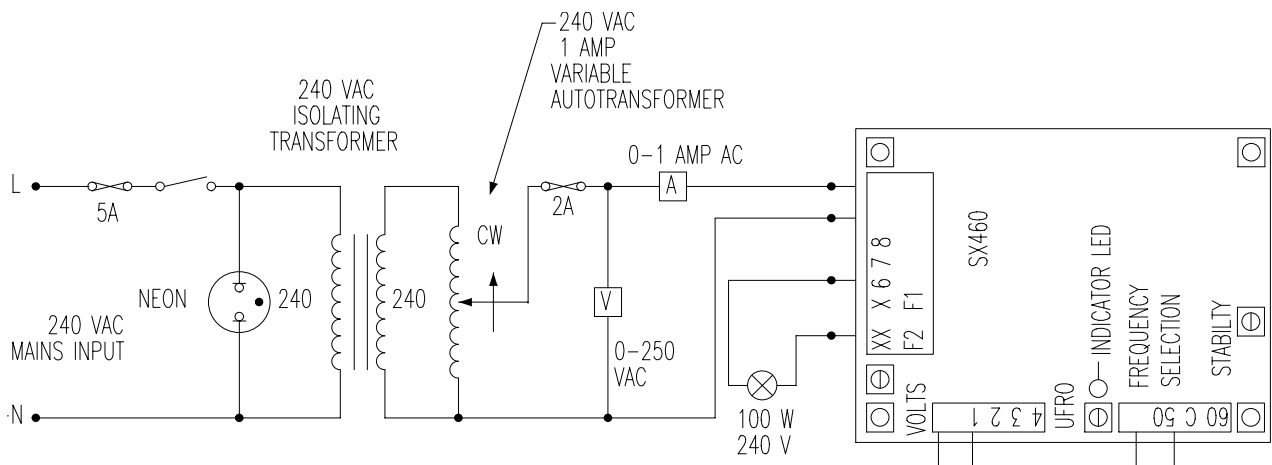

Figure 5-16. Automatic Voltage Regulator (Sheet 1 of 2)

REPLACE

WARNING

Ensure that APU DC power supply is disconnected. Failure to observe this warning could result in severe injury or DEATH to personnel

WARNING

Ensure that the APU is turned off and completely de-energized before opening generator housing. Failure to observe this warning could result in severe injury or DEATH to personnel.

- a. Remove four screws (JTACS), or slotted hex-head bolts (SICPS and WIN-T), flat and lock washers (4), and remove generator housing top cover (3).
- b. Remove two screws, wing nuts and lock washers (6a) (JTACS), or four slotted hex-head bolts (SICPS and WIN-T), flat and lock washers (6), and remove generator housing side cover (5) (muffler side).
- c. Refer to foldout FO-1 (SICPS/WIN-T) or F0-7 (JTACS) and tag and disconnect electrical leads to AVR (1).
- d. Remove four nuts with captive washers (2) and AVR (1).
- e. Install AVR (1) and secure with four nuts with captive washers (2).
- f. Reconnect electrical leads to AVR (1).
- g. Install generator housing side cover (5) and secure with two screws, wing nuts and lock washers (6a) (JTACS), or four slotted hex-head bolts (SICPS and WIN-T), flat and lock washers (6).
- h. Install generator housing top cover (3) and secure with four screws (JTACS), or four slotted hex-head bolts (SICPS and WIN-T), flat and lock washers (4).

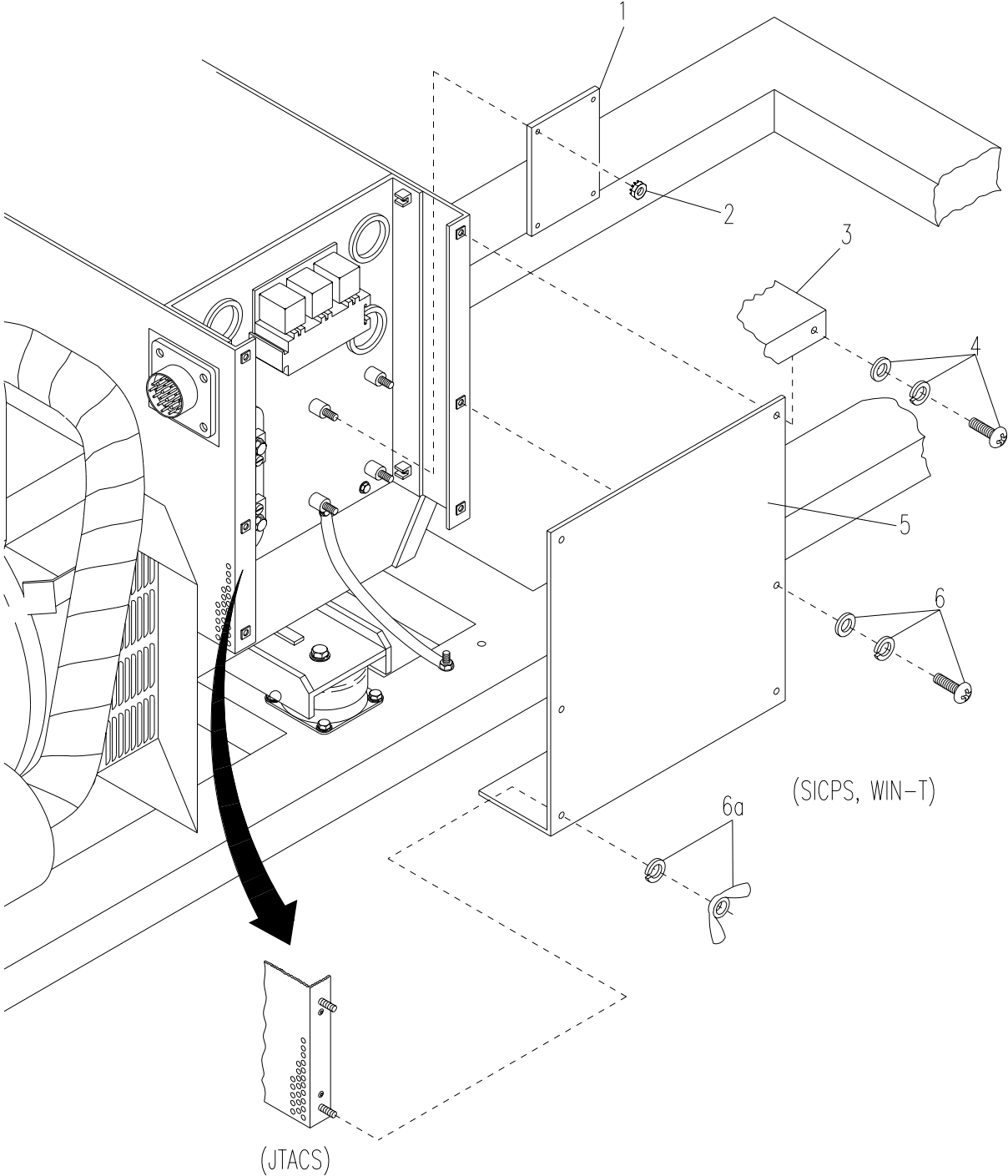

Figure 5-16. Automatic Voltage Regulator (Sheet 2)

5.23. REGULATOR BOX.

This task covers: Replace

INITIAL SETUP

Tools

General Mechanic's Tool Kit
(Item 1, Appendix B)

Materials/Parts

Regulator Box

Equipment Conditions

MASTER ON-OFF switch on APU control unit set to off.

APU DC Box Wiring Harness J1 removed (para 5.26.).

AVR removed (para 5.22.).

Relay sockets removed (para 5.21.).

Current shunt removed (para 4.55.).

Ground strap removed (para 5.54.).

WARNING

Ensure that APU DC power supply is disconnected. Failure to observe this warning could result in severe injury or DEATH to personnel.

WARNING

Ensure that the APU is turned off and completely de-energized before opening generator housing. Failure to observe this warning could result in severe injury or DEATH to personnel.

REPLACE

- a. Remove four screws (JTACS), or slotted hex-head bolts (SICPS and WIN-T), flat and lock washers (7, Figure 5-17), and generator housing top cover (6).
- b. Remove two screws, wing nuts and lock washers (9a) (JTACS), or four slotted hex-head bolts (SICPS and WIN-T), flat and lock washers (9), and generator housing side cover (8) (muffler side).
- c. Remove four screws (JTACS), slotted hex bolts, and lock washers (SICPS and WIN-T) (5) securing regulator box (2) to generator housing (11).
- d. Remove three bolts and lock washers (4) (JTACS), or three bolts, flat and lock washers (SICPS and WIN-T), and regulator box (2).
- e. Remove two captive screws (1) and flat washers from regulator box (2).

- f. Install two current shunt mounting screws (12) on new regulator box (2).
- g. Install two captive screws (1) and flat washers from regulator box (2).
- h. Install regulator box (2) on generator (10) and secure with three bolts and lock washers (4) (JTACS), or three bolts, flat and lock washers (SICPS and WIN-T).
- i. Secure regulator box (2) to generator housing (11) with four screws, machine screws (JTACS) or slotted hex-head bolts (SICPS and WIN-T), and lock washers (5).
- j. Install generator housing side cover (muffler side) (8) and secure with two screws, wing nuts and lock washers (9a) (JTACS), or four slotted hex-head bolts (SICPS and WIN-T), flat and lock washers (9).
- k. Install generator housing top cover (6) and secure with four screws (JTACS), or slotted hex-head bolts (SICPS and WIN-T), flat and lock washers (7).

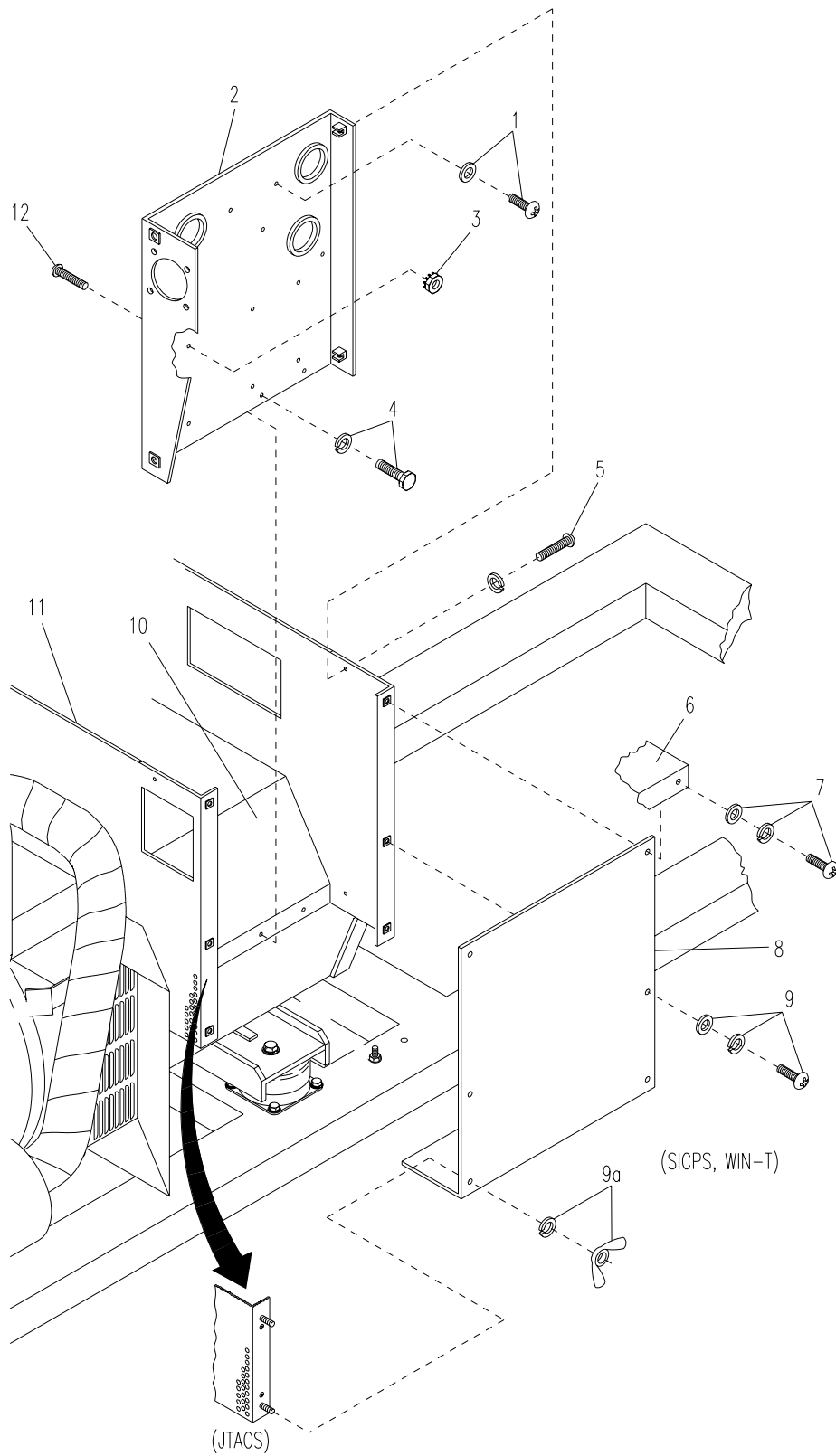

Figure 5-17. Regulator Box

5.24. GENERATOR, 10 kW, 60 Hz.

This task covers: Replace

INITIAL SETUP

Tools

General Mechanic's Tool Kit
(Item 1, Appendix B)

Shop Equipment, Electrical Repair,
Semitrailer Mounted
(Item 3, Appendix B)

DS Shop Equipment
(Item 52, Appendix B)

Materials/Parts

Generator Assembly

Equipment Conditions

MASTER ON-OFF switch on APU control unit set to OFF.

Governor control assembly disconnected (para 4.48.).

Wiring harness, Engine P1 disconnected (para 5.27.).

Air filter removed (para 4.45.).

WARNING

Ensure that APU DC power supply is disconnected. Failure to observe this warning could result in severe injury of DEATH to personnel.

Ensure that the APU is turned off and completely de-energized before opening generator housing. Failure to observe this warning could result in severe injury of DEATH to personnel.

REPLACE

- a. Remove four screws (JTACS), or slotted hex-head bolts (SICPS and WIN-T), flat and lock washers (4, Figure 5-18), and generator housing top cover (5).
- b. Remove two screws, wing nuts and lock washers (9a) (JTACS), or four slotted hex-head bolts (SICPS and WIN-T), flat and lock washers (9), and generator housing side cover (8) (muffler side).
- c. Remove four screws (JTACS), or four slotted hex-head screws (SICPS and WIN-T), flat and lock washers (5, Figure 5-12), generator housing side cover (4) (fuel pump side).
- d. Refer to FO-1 (SICPS, WIN-T) or FO-7 (JTACS). Tag and remove electrical leads F1 and F2 from relay board inside regulator box.
- e. Refer to FO-1 (SICPS, WIN-T) or FO-7 (JTACS). Tag and remove ground wire U2L0 inside the generator housing behind the electrical output terminal board.
- f. Refer to FO-1 (SICPS, WIN-T) or FO-7 (JTACS). Tag and remove electrical leads U1T1, U5T3, and U6T4 from terminals 1, 3 and 5 on the main contactor.

- g. Remove six nuts with captive washers (8, Figure 5-12) (JTACS) securing relay board (6) to vibration mounts (3), or six screws, flat and lock washers, vibration mounts (3) and hex nuts (SICPS and WIN-T), securing relay board (6) to relay box.

NOTE

There are electrical leads and a ground wire attached to the generator housing with one set of hardware in the regulator box.

- h. Remove three bolts and lock washers (4, Figure 5-17) (JTACS), or three bolts, flat and lock washers (SICPS and WIN-T) and regulator box (2). Tag and remove electrical leads and ground wire.
- i. Remove two bolts (7, Figure 5-13) (JTACS) and lock washers (6), or three bolts (SICPS and WIN-T), flat and lock washers, and regulator box (1).
- j. Remove eight bolts and lock washers (10, Figure 5-18), two generator air deflectors (9), and two generator grills (8).
- k. Secure lifting device to lifting eyes (14 and 15) on generator.
- l. Reach inside generator air vents and remove six bolts and lock washers (7) securing generator to flywheel adapter (13).
- m. On generator exterior, remove four socket head screws and lock washers (16) (two on top and two on bottom) securing generator coupling (18) to bell housing (17).
- n. Reach inside generator air vents and remove four nuts and lock washers (11) from four studs (12) (two on each side of APU) securing generator coupling (18) to bell housing (17).
- o. Remove hex-head screws, lock washers and spacers (21) securing generator (19) to generator mount (20).

WARNINGS

- A heavy lifting device and two personnel are required to lift the diesel engine on and off the frame. DO NOT use a lifting device with lifting capacity of less than 500 pounds (226.8 KG).
- DO NOT stand or sit on the 10 kW generator as it is being hoisted, lowered, or transported.
- DO NOT lift the 10 kW generator over personnel.
- When using lift ring, ensure that a closed ring with safety latch is used. NO OPEN HOOKS are to be used when lifting 10 kW generator.
- Lift ring must have a swivel attached to prevent equipment from swinging.
- Hard hats must be worn when 10 kW generator is removed by overhead lift ring.

Failure to observe these warnings could result in severe injury to personnel or DEATH.

- p. Using lifting device, lift generator (19) off generator mount (20) and set down on firm, flat surface.
- q. Using lifting device, align studs (12) on bell housing (17) and holes in generator coupling (18) and install generator (19) to engine.
- r. Secure generator (19) to mount (20) with hex-head screws, lock washers and spacers (21). Torque between 29 and 34 ft-lbs (39.4 and 46.2 Nm).
- s. Reach inside generator air vent and secure generator coupling to bell housing by installing four nuts and lock washers (11) on four studs (12).
- t. On generator exterior, secure generator coupling (18) to bell housing (17) by installing four socket head screws and lock washers (16) (two on top and two on bottom).
- u. Secure generator to flywheel adaptor (13) with six bolts and lock washers (7). Torque between 28.9 and 33.3 ft-lbs (39.2 and 45.1 Nm).
- v. Install two generator grids (13) and air deflectors (9) and secure with eight bolts and lock washers (10).
- w. Remove lifting device.
- x. Install two bolts (7, Figure 5-13) (JTACS) and lock washers (6), or three bolts (SICPS and WIN-T), flat and lock washers, to regulator box, (1) and secure to generator housing.

NOTE

Ensure ground wire and electrical leads are installed in the same place.

ARMY TM 9-6115-670-14&P

- y. Install three bolts and lock washers (4, Figure 5-17) (JTACS), or three bolts, flat and lock washers (SICPS and WIN-T), to regulator box (2), electrical leads and ground wire. Secure to generator housing.
- z. Install six nuts with captive washers (8, Figure 5-12) (JTACS) securing relay board (6) to vibration mounts (3), or six screws, flat and lock washers, vibration mounts (3) and hex nuts (SICPS and WIN-T) securing relay board (6) to relay box.
- aa. Refer to FO-1 (SICPS, WIN-T) or FO-7 (JTACS) and install electrical leads U1T1, U5T3 and U6T4 to terminals 1,3 and 5 on the main contactor.
- ab. Refer to FO-1 (SICPS, WIN-T) or FO-7 (JTACS) and install ground wire U2L0 to the electrical output terminal board inside the generator housing.
- ac. Refer to FO-1 (SICPS, WIN-T) or FO-7 (JTACS) and install electrical leads F1 and F2 to relay board inside regulator box.
- ad. Install four screws (JTACS), or four slotted hex-head screws (SICPS and WIN-T), flat and lock washers (5, Figure 5-12) to generator housing side cover (4) and secure to generator housing (fuel pump side).
- ae. Install two screws, wing nuts and lock washers (9a, Figure 5-18) (JTACS), or four slotted hex-head bolts (SICPS and WIN-T), flat and lock washers to generator housing side cover (8) and secure to generator housing (muffler side).
- af. Install generator housing top cover (5) and secure with four screws (JTACS), or slotted hex-head bolts (SICPS and WIN-T), flat and lock washers (4).

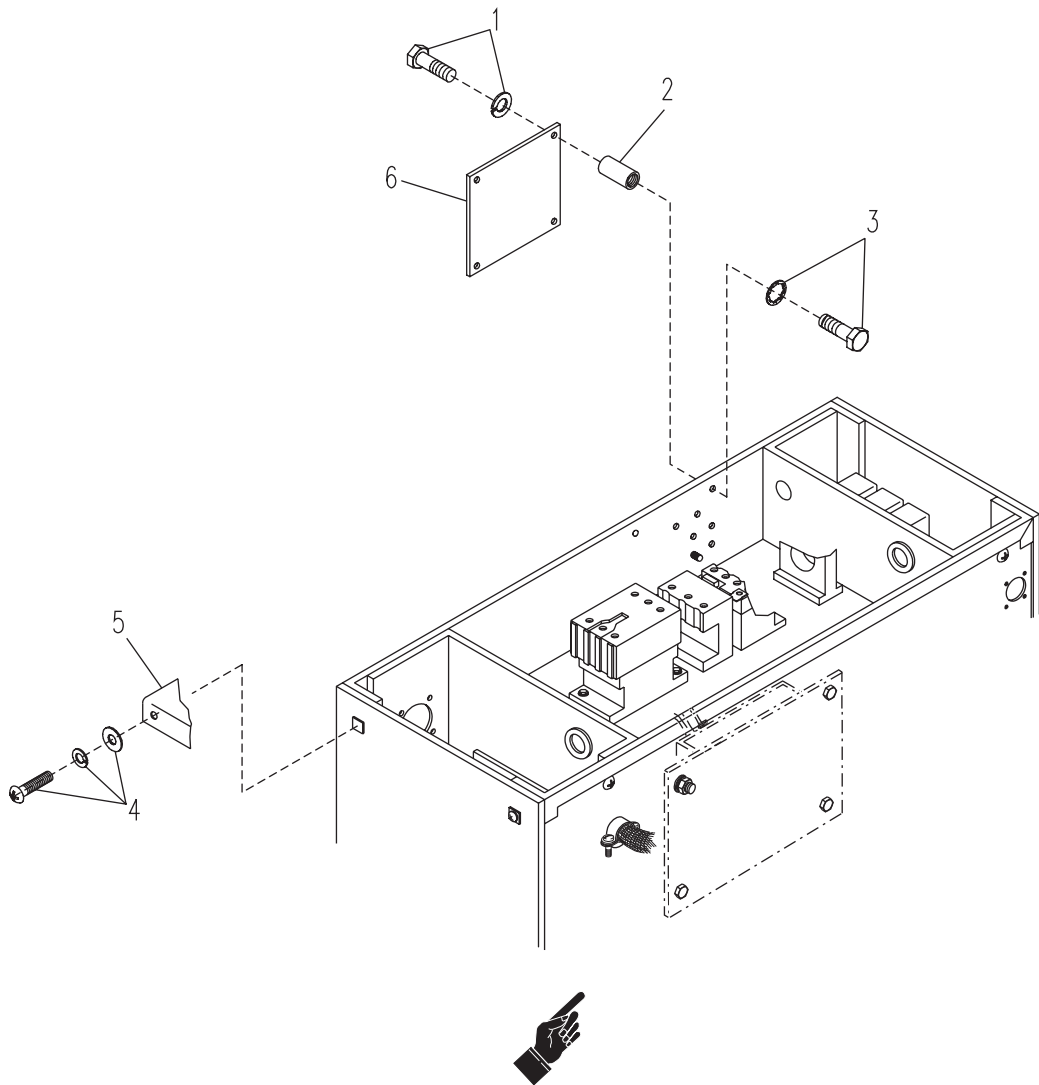

Figure 5-18. Generator, 10 kW, 60 Hz (Sheet 1 of 5)

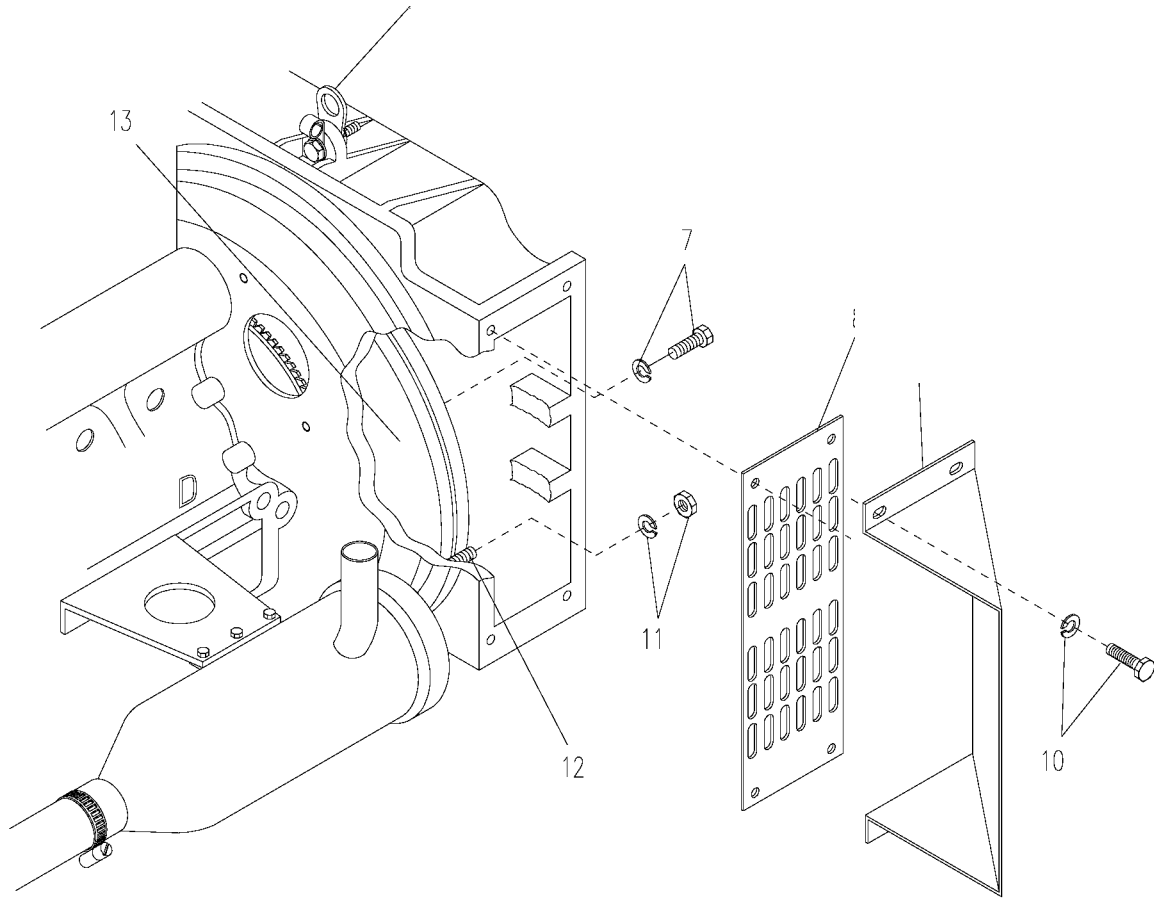

Figure 5-18. Generator, 10 kW, 60 Hz (Sheet 2)

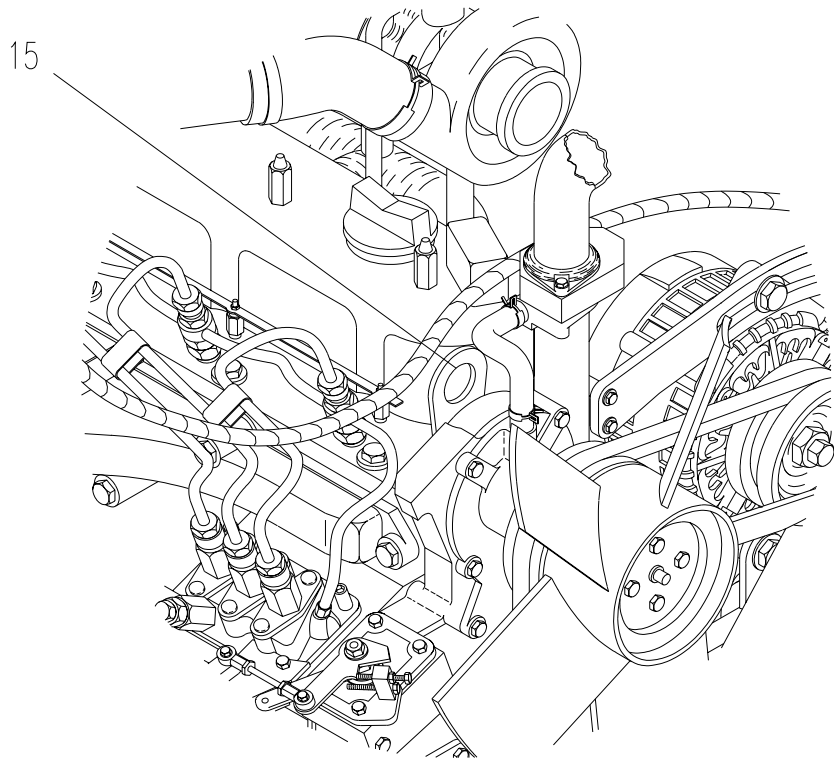

Figure 5-18. Generator, 10 kW, 60 Hz (Sheet 3)

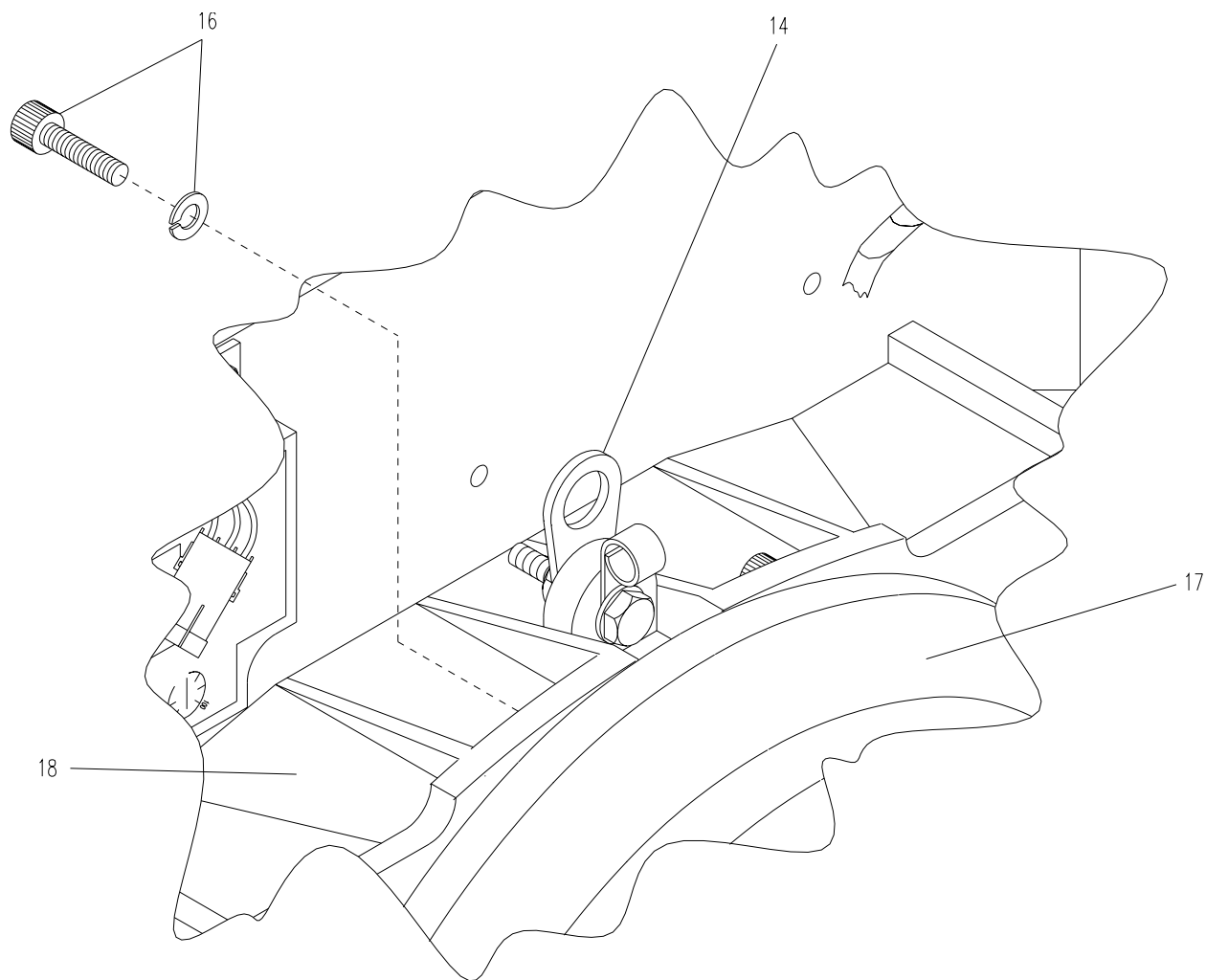

Figure 5-18. Generator, 10 kW, 60 Hz (Sheet 4)

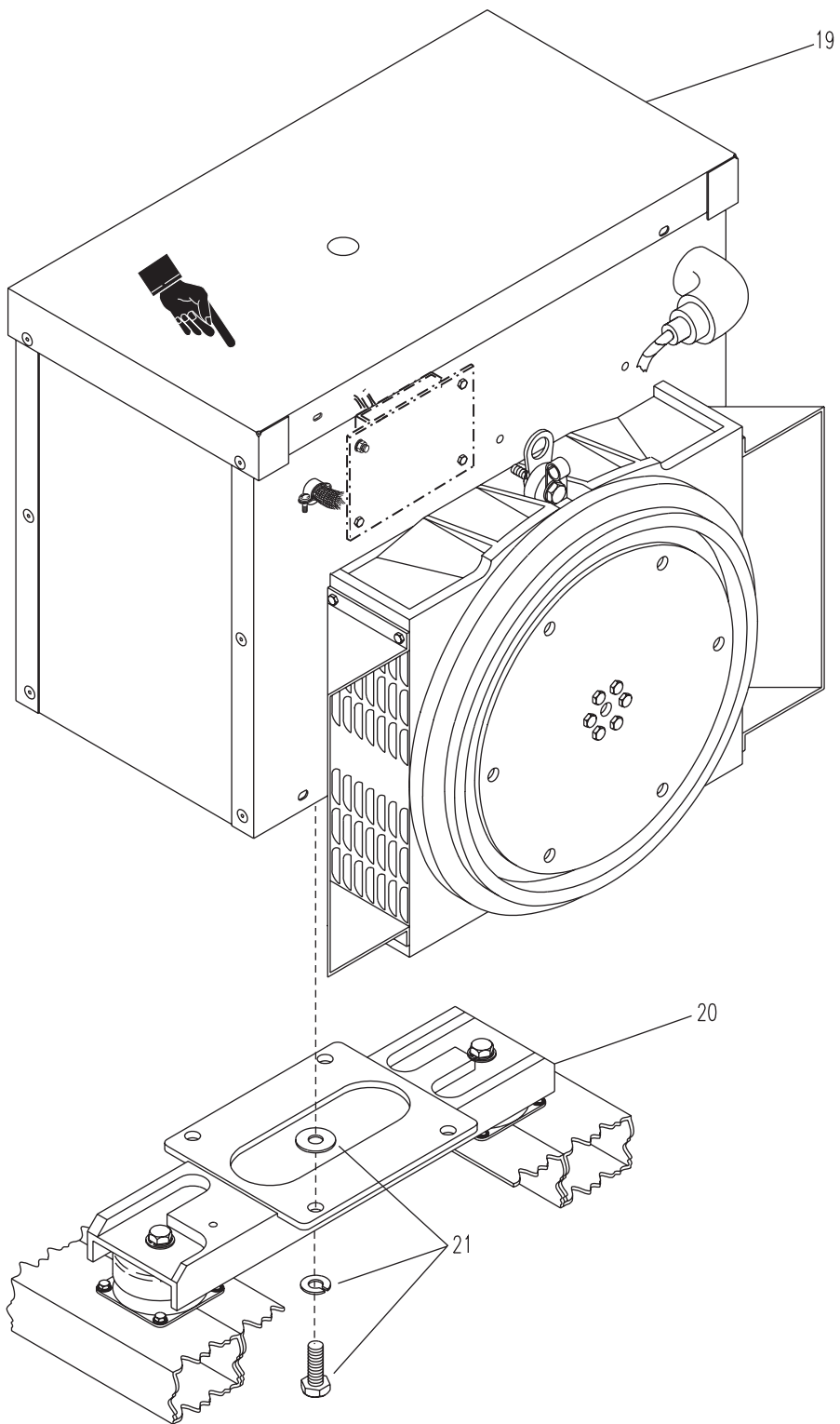

Figure 5-18. Generator, 10 kW, 60 Hz (Sheet 5)

5.25. WIRING HARNESS REPAIR.

This task covers: Repair

INITIAL SETUP

Tools

General Mechanic's Tool Kit
(Item 1, Appendix B)

Shop Equipment, Electrical Repair,
Semi-trailer Mounted
(Item 3, Appendix B)

Pin Remover
(Item 28, Appendix B)

Heater, Gun Type, Electric
(Item 33, Appendix B)

Materials/Parts

Wiring Harness, Engine P1
APU DC Box Wiring Harness J3
Wiring Harness J1
Wiring Harness J2

References

Figures FO-1 and FO-2, FO-3, FO-4,
FO-5 or FO-7

Equipment Conditions

MASTER ON-OFF switch on APU control
unit set to OFF

WARNING

Ensure that APU DC power supply is disconnected. Failure to observe this warning could result in severe injury or DEATH to personnel.

WARNING

Ensure that the APU is turned off and completely de-energized before opening generator housing. Failure to observe this warning could result in severe injury or DEATH to personnel.

NOTE

Use this procedure to repair APU wiring harnesses Engine P-1, J-1, J-2, APU DC Box J-3, and interconnect control cable

REPAIR

- a. Crimp-on terminals and lugs.
 - (1) Remove terminal or lug by cutting lead at base of terminal or lug.
 - (2) Strip no more than 1/4 in. (6.35 cm).
 - (3) Using a crimping tool, crimp terminal or lug to lead.
- b. Connectors with pins.
 - (1) Using pin puller, push pin out through back of connector.
 - (2) Cut lead at base of pin.

(3) Strip lead no more than 1/4 in. (6.35 cm).

(4) Using crimping tool, crimp pin to lead.

(5) Push pin back into connector body.

c. Solder pins and jacks.

(1) Remove pins or jacks from connector body.

(2) Carefully cut away insulation sleeving and expose soldered connection.

(3) Unsolder and remove wire leads from terminals.

(4) Slide insulation sleeving over the wire leads. Solder wire leads to appropriate pins and jacks.

(5) Slide insulation sleeving over soldered connection. Use heat gun set on heat mode to shrink sleeving and secure soldered connection.

(6) Use heat gun set on cool mode to cool soldered connection and sleeving.

(7) Install pins or jacks from connector body.

5.26. APU DC BOX WIRING HARNESS J3.

This task covers: a. Inspect b. Test c. Repair d. Replace

INITIAL SETUP

Tools

General Mechanic's Tool Kit
(Item 1, Appendix B)

Shop Equipment, Electrical Repair,
Semitrailer Mounted
(Item 3, Appendix B)

Materials/Parts

Wiring Harness J-3

Strap, Tiedown, Elect.
(Item 22, Appendix F)

References: Figures FO-1 (SICPS/WIN-T) or F0-7
(JTACS) and FO-3

Equipment Conditions

MASTER ON-OFF switch on APU control unit set
to OFF.

Air filter removed (para 4.45.).

WARNING

Ensure that APU DC power supply is disconnected.
Failure to observe this warning could result in severe
injury or DEATH to personnel.

WARNING

Ensure that the APU is turned off and completely de-
energized before opening generator housing.
Failure to observe this warning could result in severe
injury or DEATH to personnel.

INSPECT

Visually inspect for damaged wires or components.

TEST

NOTE

Disconnect test leads one at a time. Reconnect after testing.

- a. Remove four screws (JTACS), or slotted hex-head bolts (SICPS and WIN-T), flat and lock washers (1, Figure 5-19), and generator housing top cover (2).
- b. Remove four screws (JTACS), or slotted hex-head bolts (SICPS and WIN-T), flat and lock washers (10), and generator housing side cover (11) (fuel transfer pump side).
- c. Remove two screws, wing nuts and lock washers (JTACS), or four slotted hex-head bolts (SICPS and WIN-T), flat and lock washers (9), and generator housing side cover (8) (muffler side).
- d. Refer to Table 5-1 and use a Multi-meter to test for continuity between pins at connector J3 (4) and corresponding leads.
- e. If no continuity is found in one or more positions, repair or replace wiring harness.
- f. Using a Multi-meter, test for continuity between each pin position and connector shell of J3 (4).
- g. If continuity is found in one or more pin positions, repair or replace wiring harness.

Table 5-1. APU DC Box Wiring Harness J3 Continuity Test

Wire Ref No.	Termination		Wire Ref No.	Termination		Wire Ref No.	Termination	
	From	To		From	To		From	To
1	J3-A	CT2B	4	J3-D	F3D	7	J3-J	J
2	J3-B	F1BA	5	J3-E	VR1	8	J3-K	K
3	J3-C	F2C	6	J3-F	VR2	9	J3-L	L
10	J3-M	M	15	J3-S	S	20	J3-X	X
11	J3-N	R	16	J3-T	T	21	J3Y-Y	Y
12	J3-P	S3	17	J3-U	K3, 87	22	J3-Z	Z
13	J3-Q	S4	18	J3-V	V			
14	J3-R	N	19	J3-W	W			

REPAIR

Refer to para 5.25. to repair APU DC BOX Wiring Harness J3.

REPLACE

- a. Tag and disconnect wiring harness J-3 electrical leads (7).
- b. Remove four socket head screws (3), lock washers (5), nuts (6) and connector J3 (4).

CAUTION

Take care not to cut wires or other APU components when removing tiedown straps.

NOTE

When removing, make note of tiedown strap locations. Wiring harness will need to be secured at approximately the same places.

NOTE

Cut and remove tiedown straps as needed to remove wiring harness.

- c. Cut and remove tiedown straps as needed to remove wiring harness.
- d. Remove wiring harness from generator housing.
- e. Refer to old wiring harness and tag leads on new wiring harness.
- f. Install connector J3 (4) in generator housing and secure with four socket head screws (3), lock washers (5), and nuts (6).
- g. Connect wiring harness leads (7) to appropriate terminals. Remove tags.

ARMY TM 9-6115-670-14&P

- h. Secure tiedown straps to wiring harness as necessary to ensure wires are not able to move around.
- i. Install generator housing side cover (8) and secure with two screws, wing nuts and lock washers (JTACS), or four slotted hex-head bolts (SICPS and WIN-T), flat and lock washers (9).
- j. Install generator housing side cover (11) and secure with four screws, (JTACS), or slotted hex-head bolts (SICPS and WIN-T), flat and lock washers (10).
- k. Install generator housing top cover (2) and secure with four screws (JTACS), or slotted hex-head bolts (SICPS and WIN-T), flat and lock washers (1).

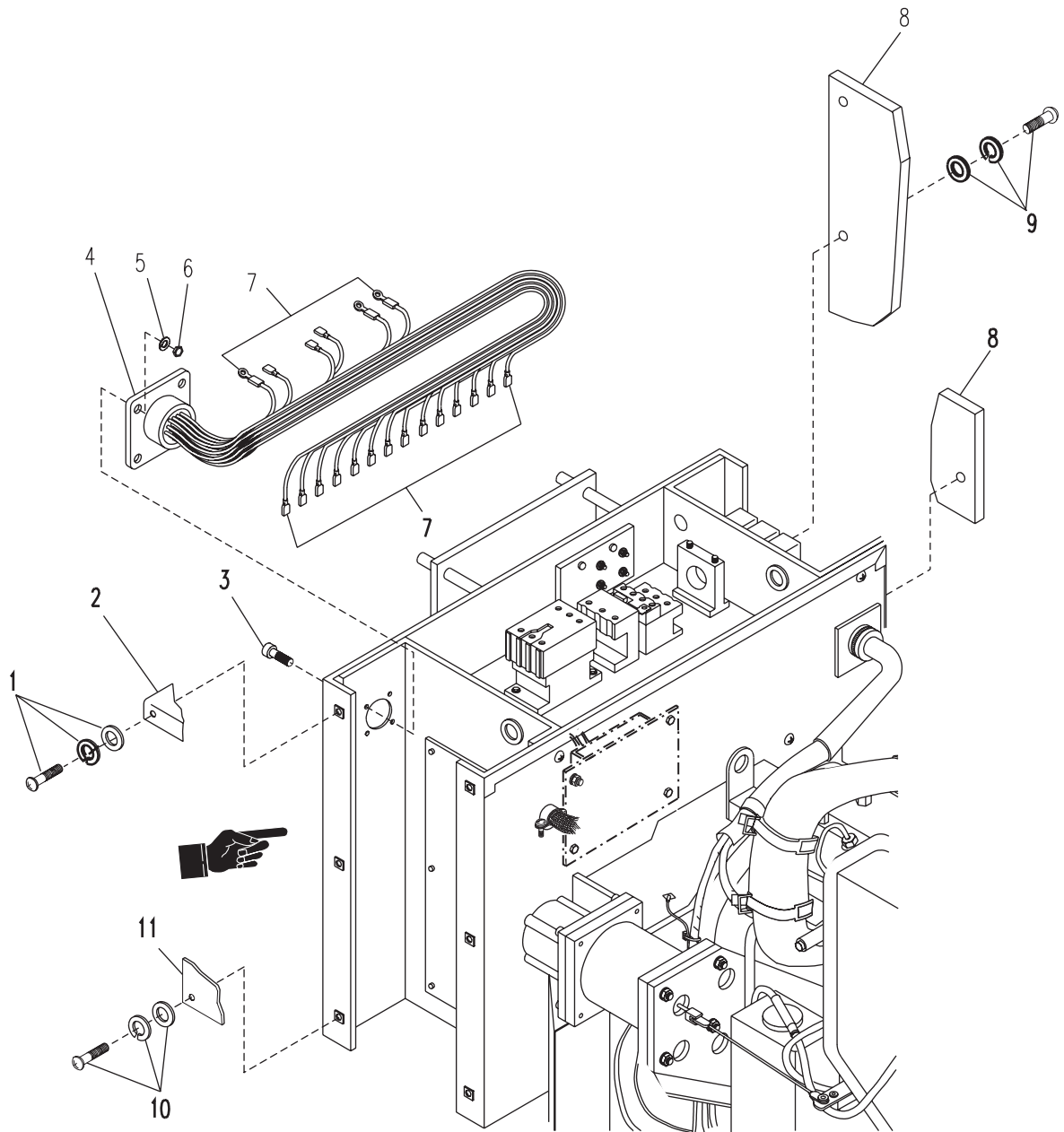

Figure 5-19. APU DC Box Wiring Harness J3

5.27. WIRING HARNESS, ENGINE P1.

This task covers: a. Inspect b. Test c. Repair d. Replace

INITIAL SETUP

Tools

General Mechanic's Tool Kit
(Item 1, Appendix B)

Shop Equipment, Electrical Repair,
Semi-trailer Mount
(Item 3, Appendix B)

Materials/Parts

Wiring Harness, Engine P1

Wire Strap, Tie-down, Elect.
(Item 22, Appendix F)

References: Figures FO-1 (SICPS/WIN-T) or FO-7
(JTACS) and FO-2

Equipment Conditions

Master ON-OFF switch in APU control unit set to OFF.

Air Filter removed (para 4.45)

WARNING

Ensure that APU DC power supply is disconnected. Failure to observe this warning could result in severe injury or DEATH to personnel.

WARNING

Ensure that the APU is turned off and completely de-energized. Failure to observe this warning could result in severe injury or DEATH to personnel.

INSPECT

Visually inspect for damaged wires or components.

TEST

NOTE

Disconnect test leads one at a time, observe each location. Reconnect after testing.

- a. Refer to Table 5-2 and use a Multi-meter to test for continuity between connector P1 pins (5, Figure 5-20) and corresponding leads.
- b. If no continuity is found in one or more positions, repair or replace control interconnect cable.
- c. Using a Multi-meter, test for continuity between each pin position and connector shell of P1.
- d. If continuity is found in one or more pin positions, repair or replace wiring harness.

Table 5-2. Engine Wiring Harness P1 Continuity Test

Wire Ref No.	Termination		Wire Ref No.	Termination		Wire Ref No.	Termination	
	From	To		From	To		From	To
1	P1-A	P4-A	6	P1-F	P4-C	11	P1-N	WTS
2	P1-B	P4-B	7	P1-J	SB	12	P1-P	P8-A
3	P1-C	P5	8	P1-K	ALT	13	P1-R	P7-B
4	P1-D	STR	9	P1-L	GP	14	P1-S	P7-D
5	P1-E	AF	10	P1-M	MH	15	P1-T	P7-A
16	P1-U	P8-B	18	P1-W	TS			
17	P1-V	OPS	19	P1-X	P7-C			

REPAIR

Refer to para 5.25. for repair of Engine Wiring Harness P1.

REPLACE

- a. Tag and disconnect connectors P1 (5), P4 (3), P5 (4), P7 (1), and P8 (2).
- b. Tag and disconnect nine electrical leads (6).

CAUTION

Take care not to cut wires or other APU components when removing tiedown straps.

NOTE

When removing, make note of tiedown strap locations. Wiring harness will need to be secured at approximately the same places.

NOTE

Cut and remove tiedown straps as needed to remove wiring harness.

- c. At generator coupling, remove one bolt (12), washer (11), nut (7), lock washer (8), lifting eye (9), and wire loop clamp (10).
- d. Remove screw and lock washer (13) securing wire loop clamp (14) to injection nozzle lines (15) and remove wire clamp (14).
- e. Cut and remove tiedown straps securing wiring harness.
- f. Remove wiring harness

ARMY TM 9-6115-670-14&P

- g. Referring to old wiring harness, tag new wiring harness.
- h. Place wiring harness on engine.
- i. Reconnect nine electrical leads (6). Remove tags.
- j. Reconnect connectors P1 (5), P4 (3), P5 (4), P7 (1), and P8 (2).
- k. Install wire loop clamp (10) on wire harness and secure along with lifting eye (9), one bolt (12), washer (11), lock washer (8), and nut (7).
- l. Install wire loop clamp (14) on wire harness and secure to injection nozzle lines (15) with screw and lock washer (13).
- m. Secure wiring harness with tiedown straps.

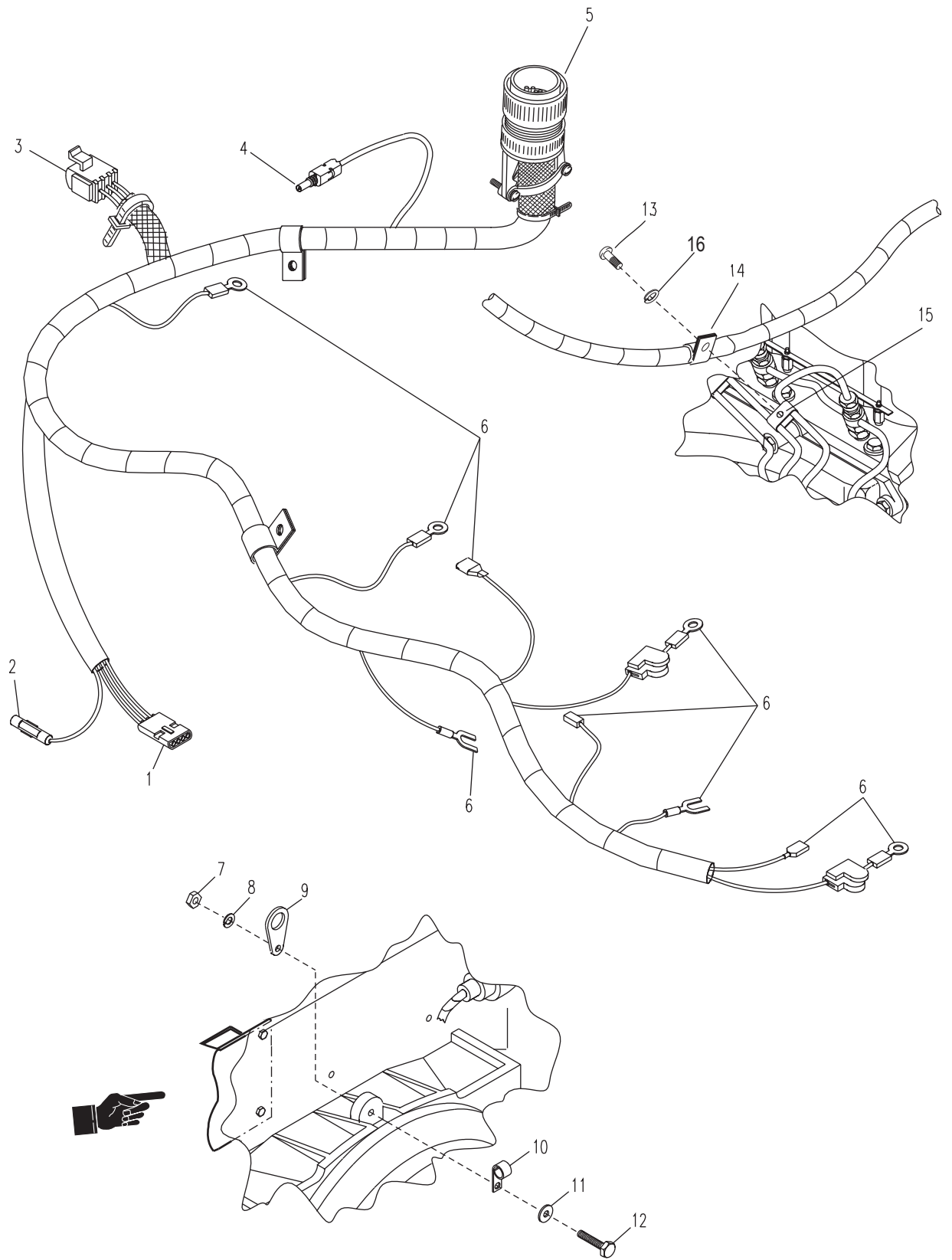

Figure 5-20. Engine Wiring Harness P1

5.28. WIRING HARNESS J1

This task covers: a. Inspect b. Test c. Repair d. Replace

INITIAL SETUP

Tools

General Mechanic's Tool Kit
(1, Appendix B)

Shop Equipment, Electrical Repair,
Semi-trailer Mounted
(Item 3, Appendix B)

Materials/Parts

Wiring Harness J1

Strap, Tie-down, Elect.
(Item 22, Appendix F)

References: Figures FO-1 (SICPS/WIN-T) or FO-7
(JTACS) and FO-4

Equipment Conditions

MASTER ON-OFF switch on APU control unit (Item
set to OFF

Air filter removed (para 4.45.).

WARNING

Ensure that APU DC power supply is disconnected.
Failure to observe this warning could result in
severe injury or DEATH to personnel.

WARNING

Ensure that the APU is turned off and completely de-
energized before opening generator housing.
Failure to observe this warning could result in severe
injury or DEATH to personnel.

INSPECT

Visually inspect for damaged wires or components.

TEST

NOTE

Disconnect test leads one at a time. Reconnect after
testing.

- a. Remove four screws (JTACS), or slotted hex-head bolts (SICPS and WIN-T), flat and lock washers (10, Figure 5-21), and remove the generator housing top cover (11).
- b. Remove four screws (JTACS), or slotted hex-head bolts (SICPS and WIN-T), flat and lock washers (9), and remove generator housing side cover (8) (fuel transfer pump side).
- c. Remove two screws, wing nuts and lock washers (JTACS), or four slotted hex-head bolts (SICPS and WIN-T), flat and lock washers (6), and remove generator housing side cover (5) (muffler side).
- d. Refer to Table 5-3 and use a Multi-meter to test for continuity between pins at connector J1 (4, Figure 5-21) and corresponding leads (1).
- e. If no continuity is found in one or more positions, repair or replace wiring harness.
- f. Using a Multi-meter, test for continuity between each pin position and connector shell of J1 (4).
- g. If continuity is found in one or more pin positions, repair or replace wiring harness...

Table 5-3. Wiring Harness J1 Continuity Test

Wire Ref. No.	Termination		Wire Ref. No.	Termination		Wire Ref. No.	Termination	
	From	To		From	To		From	To
1	J1-A	R187	3	J1-B	R130	5	R186	R230
2	R287	R187	4	R186	R130	6	J1-C	IGN
7	J3-J	J	13	J1-M	MH	19	J1-U	GND
8	J1-E	IGN	14	J1-N	WT	20	J1-V	BC19
9	J1-F	R185	15	J1-P	FP	21	J1-W	BC21
10	J1-J	S1	16	J1-R	FPR	22	J1-Z	BC23
11	J1-K	S2	17	J1-S	GND			
12	J1-L	GP	18	J1-T	GND			

REPAIR

Refer to para 5.25. for repair of Wiring Harness J1.

REPLACE

WARNING

Ensure that APU DC power supply is disconnected. Failure to observe this warning could result in severe injury or DEATH to personnel.

WARNING

Ensure that the APU is turned off and completely de-energized before opening generator housing. Failure to observe this warning could result in severe injury or DEATH to personnel.

- a. Tag and disconnect wiring harness electrical leads (1, Figure 5-21) and hex head socket captive screws (JTACS and WIN-T).
- b. Remove connector J1 (4) from housing by removing four pan head screws (caged nuts (SICPS), machine screws (JTACS and WIN-T)) (7), assembled nuts (2), and lock washers (3).

CAUTION

Take care not to cut wires or other APU components when removing tiedown straps.

NOTE

Cut and remove tiedown straps as needed to remove wiring harness.

NOTE

When removing, make note of tiedown strap locations. Wiring harness will need to be secured at approximately the same places.

- c. Cut and remove tiedown straps as needed to remove wiring harness.
- d. Remove wiring harness from generator housing.
- e. Refer to old wiring harness and tag leads on new wiring harness.
- f. Install connector J1 (4) and secure with four screws, (caged nuts (SICPS), machine screws (JTACS and WIN-T)) (7), lock washers (3), and nuts (2).
- g. Reconnect wiring harness electrical leads (1). Remove tags.
- h. Secure wiring harness with tiedown straps as needed.
- i. Install generator housing side cover (5) (muffler side) and secure with two screws, wing nuts and lock washers (JTACS), or four slotted hex-head bolts (SICPS and WIN-T), flat and lock washers (6).
- j. Install generator housing side cover (8) (fuel transfer pump side) and secure with four screws (JTACS), or slotted hex-head bolts (SICPS and WIN-T), flat and lock washers (9).
- k. Install generator housing top cover (11) and secure with four screws (JTACS), or slotted hex-head bolts (SICPS and WIN-T), flat and lock washers (10).

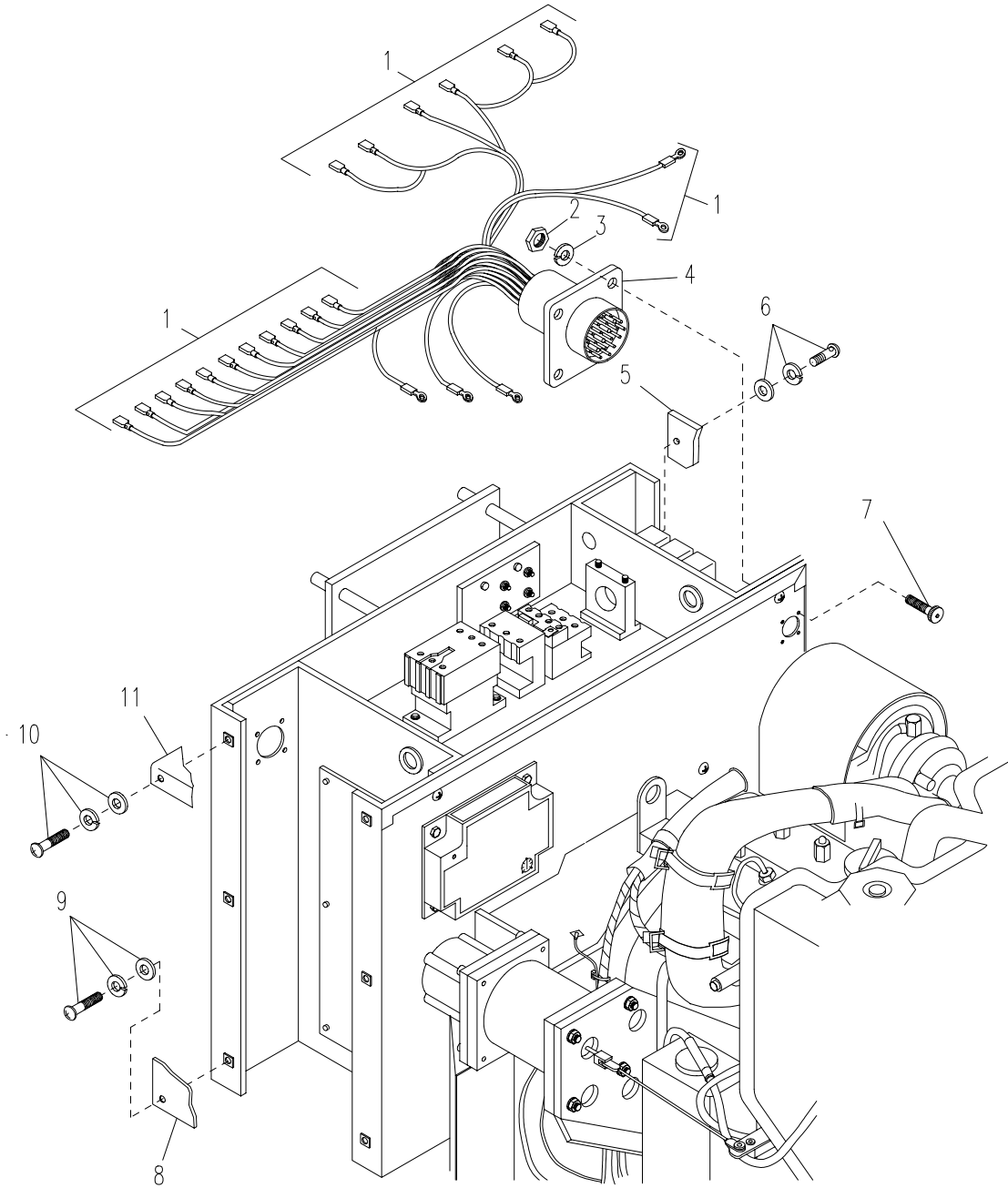

Figure 5-21. Wiring Harness J1

5.29. WIRING HARNESS CONTROL CABLE.

This task covers: a. Test b. Repair c. Replace

INITIAL SETUP

Tools

General Mechanic's Tool Kit
(Item 1, Appendix B)

Shop Equipment, Electrical Repair,
Semitrailer Mounted
(Item 3, Appendix B)

Materials/Parts

Wiring Harness Control Cable

Reference: Foldout FO-6

Equipment Conditions

Master ON-OFF switch on APU control unit set to off.

Wiring harness control cable removed from APU and system shelter (see system TM).

TEST

- a. Refer to Table 5-4 and use a Multi-meter to test for continuity between pins connector P1 and corresponding leads.
- b. If no continuity is found in one or more positions, replace control interconnect cable.
- c. Using a Multi-meter, test for continuity between each pin position and connector shells of P2 and P3.
- d. If continuity is found in one or more pin positions, repair or replace wiring harness.

Table 5-4. Wiring Harness Control Cable Continuity Test

Wire Ref No.	Wire Color Code	Termination		Wire Ref No.	Wire Color Code	Termination	
		From	To			From	To
1	Black	P2-A	P3-A	8	Red/Black	P2-H	P3-H
2	White	P2-B	P3-B	9	Green/Black	P2-J	P3-J
3	Red	P2-C	P3-C	10	Orange/Black	P2-K	P3-K
4	Green	P2-D	P3-D	11	Blue/Black	P2-L	P3-L
5	Orange	P2-E	P3-E	12	Black/White	P2-M	P3-M
6	Blue	P2-F	P3-F	13	Red/White	P2-N	P3-N
7	White/Black	P2-G	P3-G	14	Green/White	P2-P	P3-P
15	Blue/White	P2-Q	P3-Q	21	Orange/White	P2-W	P3-W

Table 5-4. Wiring Harness Control Cable Continuity Test - Continued

Wire Ref No.	Wire Color Code	Termination		Wire Ref No.	Wire Color Code	Termination	
		From	To			From	To
16	Black/Red	P2-R	P3-R	22	Black/White/Red	P2-X	P3-X
17	White/Red	P2-S	P3-S	23	White/Black/Red	P2-Y	P3-Y
18	Orange/Red	P2-T	P3-T	24	Red/Black/White	P2-Z	P3-Z
19	Blue/Red	P2-U	P3-U				
20	Red/Green	P2-V	P3-V				

REPAIR

Refer to para 5.25. for repair of the Wiring Harness control cable.

REPLACE

Refer to the system TM for replacement of the Wiring Harness control cable.

5.30. WATER TEMPERATURE GAUGE.

This task covers: a. Test b. Replace

INITIAL SETUP

Tools

General Mechanic's Tool Kit
(Item 1, Appendix B)

Equipment Conditions

APU control unit disconnected from shelter
(JTACS and WIN-T).

Materials/Parts

Multi-meter

Water Temperature Gauge

TEST

- a. Refer to FO-1 (SICPS/WIN-T), or FO-7 (JTACS), and disconnect plug J2 from P2.
- b. Perform step "a." of REPLACE procedure to gain access to meter.
- c. Identify and tag terminal leads at rear of meter.
- d. For each terminal, disconnect female terminal from spade terminals marked "+", "-", and "S".
- e. Measure resistance on terminals marked "+" to "-" at rear of meter. Resistance reading should be 192.0 ohms +/- 10 ohms.
- f. Measure resistance on terminals marked "+" to "S" at rear of meter. Resistance reading should be 140.0 ohms +/- 5 ohms.
- g. If meter is not within the specified resistance, replace meter.

REPLACE

- a. Remove ten screws, (caged nuts (SICPS), machine screws (JTACS and WIN-T)) (1, Figure 5-22) securing APU control unit cover to chassis and remove cover.
- b. At rear of gauge (2), identify and tag terminal leads (3).
- c. Disconnect terminal leads (3) from terminals by gently pulling apart.
- d. Remove two nuts and lock washers (4) securing water temperature gauge (2) to mounting bracket.
- e. Carefully pull gauge (2) through front of APU control unit front panel (5).

- f. Position new gauge (2) in APU control unit front panel (5) mounting hole.
- g. Secure gauge (2) to mounting bracket with two nuts and lock washers (4).
- h. Install terminal leads (3) on terminals and remove tags.
- i. Secure APU control unit cover (5) to chassis with ten screws, (caged nuts (SICPS), machine screws (JTACS and WIN-T)) (1).
- j. Install APU control unit.

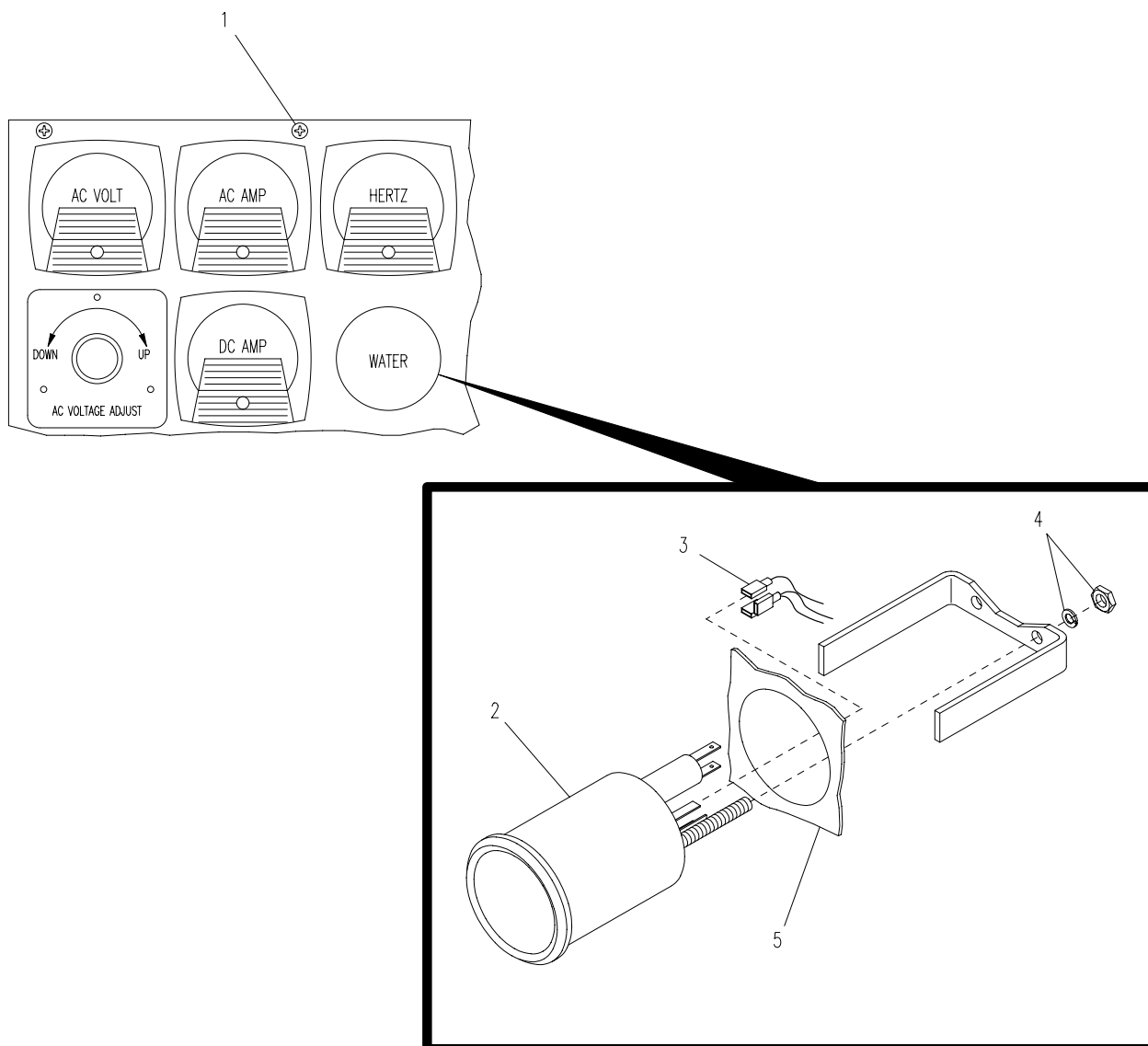

Figure 5-22. Water Temperature Gauge

5.31. WIRING HARNESS J2.

This task covers: a. Inspect b. Test c. Repair d. Replace

INITIAL SETUP

Tools

General Mechanic's Tool Kit
(Item 1, Appendix B)

Shop Equipment, Electrical, Repair,
Semitrailer Mounted
(Item 3, Appendix B)

Materials/Parts

Wiring Harness J2

Strap, Tiedown, Elect
(Item 22, Appendix J)

Reference: Figure FO-5

Equipment Conditions

APU control unit disconnected from shelter.

INSPECT

Inspect cable for damage, charring, and broken wires.

TEST

NOTE

Disconnect test leads one at a time. Reconnect after testing.

- a. Remove ten screws (caged nuts (SICPS), machine screws (JTACS and WIN-T)) (6, Figure 5-23) securing APU control unit front panel cover to chassis and remove cover.
- b. Refer to Table 5-5 and use a Multi-meter to test for continuity between pins of connector J2 and corresponding leads.
- c. If no continuity is found in one or more positions, replace wiring harness.
- d. Using a Multi-meter, test for continuity between each pin position and connector shell of J2.
- e. If continuity is found in one or more pin positions, repair or replace wiring harness.

Table 5-5. Wiring Harness J2 Continuity Test

Wire Ref No.	Termination		Wire Ref No.	Termination		Wire Ref No.	Termination	
	From	To		From	To		From	To
1	J2-A	ACA	9	J2-J	BSS1	17	J2-S	ESS1
2	J2-B	ACA+	10	J2-K	WTRS	18	J2-T	MOOS4
3	J2-C	ACV	11	J2-L	ACS3	19	J2-U	TP1-2
4	J2-D	ACV+	12	J2-M	TP1-1	20	J2-V	GND
5	J2-E	P2	13	J2-N	SPS1	21	J2-W	BSS6
6	J2-F	P3	14	J2-P	DCA	22	J2-X	TBS-5
7	J2-G	AUX1	15	J2-Q	DCA+	23	J2-Y	TBS-4
8	J2-H	AUX2	16	J2-R	SPS4	24	J2-Z	TBS-3

REPAIR

Refer to para 5.25. to repair APU DC BOX Wiring Harness J3.

REPLACE

- a. Identify and tag electrical leads.

CAUTION

Take care not to cut wires or other APU components when removing tiedown straps.

NOTE

Cut and remove tiedown straps as needed to remove wiring harness.

NOTE

When removing, make note of tiedown strap locations. Wiring harness will need to be secured at approximately the same places.

- b. Cut and remove wire ties as necessary to remove wiring harness (4).
- c. Remove non-soldered electrical leads.
- d. Remove four socket head screws (1) and nuts (5) securing connector J2 (2) to control unit box (3).
- e. Carefully pull connector J2 (2) and wiring harness (4) through hole inside of control unit box (3).

- f. Install wiring harness (4) through hole inside of control unit box (3).
- g. Secure connector J2 (2) to control unit box (3) with four socket head screws (1) and nuts (5).
- h. Install electrical leads and remove tags.
- i. Slide insulation sleeving over soldered connections. Use heat gun to shrink sleeving and secure soldered connections (JTACS and WIN-T).
- j. Secure wiring harness with wire ties as needed.
- k. Install APU control unit front panel and secure with ten screws (6).

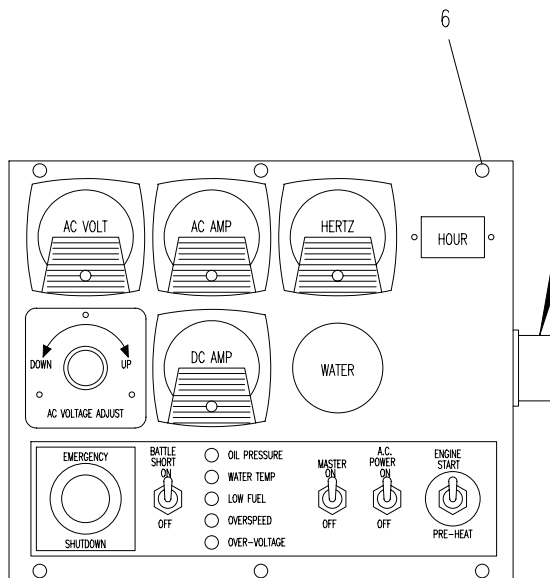
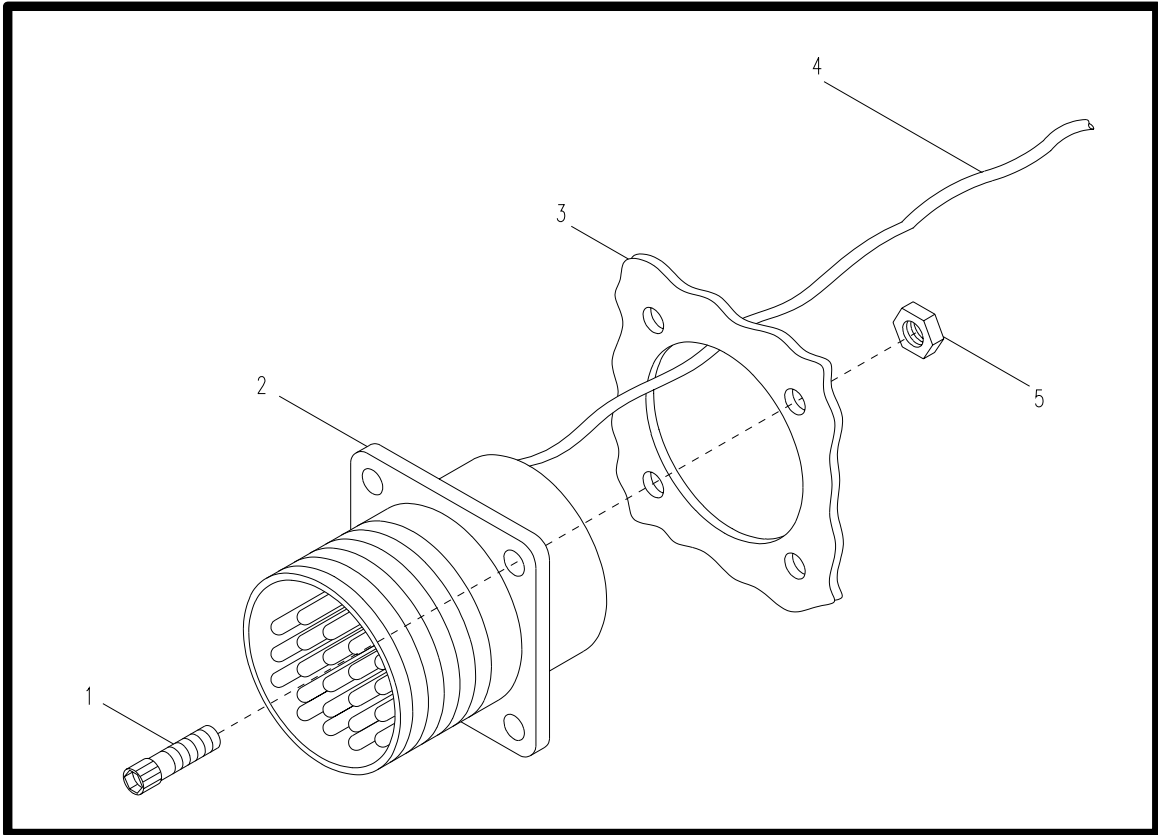

Figure 5-23. Wiring Harness J2

5.32. FRAME ASSEMBLY (MODELS MEP-903A, MEP-903B, AND MEP-903C AND VIBRATION ISOLATOR MOUNT ASSEMBLY (JTACS AND WIN-T)).

This task covers: a. Inspect b. Replace c. Repair

INITIAL SETUP

Tools

General Mechanic's Tool Kit
(Item 1, Appendix B)

Shop Equipment, Electrical Repair,
Semitrailer Mounted
(Item 3, Appendix B)

DS Shop Equipment
(Item 52, Appendix B)

Equipment Conditions

MASTER ON-OFF switch on APU control unit set to OFF.

APU Engine stopped and allowed to cool completely.

APU removed from shelter (para 5.6.).

Air filter removed (para 4.45.).

Materials/Parts

Frame Assembly (SICPS)
or
Frame Assembly (JTACS and WIN-T)
Vibration Isolator Mount Assembly

WARNING

Ensure APU is shut down and completely de-energized before performing any work on APU. Failure to observe this warning could result in severe injury or DEATH to personnel.

Personnel Required

Two

WARNING

A lifting device capable of lifting 600 pounds (271.8 KG) is required to lift APU. Failure to observe this warning could result in severe injury or DEATH to personnel.

INSPECT

Inspect frame assembly for signs of damage or corrosion.

REPLACE

CAUTION

Air intake pipe needs to be moved aside to access lifting eyes and prevent damage to equipment.

- a. Drain coolant from radiator subassembly (para 4.19.).
- b. Remove two nuts and lock washers (1, Figure 4-35) (JTACS), or two bolts (SICPS and WIN-T), securing air intake pipe to turbo charger. Slide pipe to the side.
- c. Remove two screws, flat and lock washers (15, Figure 4-5), two screws (JTACS), or two slotted hex-head screws (SICPS and WIN-T), flat and lock washers (17), and radiator support bracket (16).

- d. Remove two nuts and flat washers (2, Figure 4-6), two rubber washers (3), two lock washers and bolts (4) securing radiator (1) to radiator mount (5).
- e. Remove one bolt, flat washer and lock washer (8, Figure 4-42) and ground strap (7) from frame.
- f. Remove four bolts, flat and lock washers (9, Figure 4-19) (JTACS and WIN-T), or four bolts and flat washers (5, Figure 4-20) (SICPS) securing fuel day tank assembly to frame.
- g. (JTACS and WIN-T) remove one bolt, flat and lock washer (31, Figure 5-24) and hex nut (33) securing fuel hose clamp (32) to isolator mount.

NOTE

Do not remove fuel pump assembly from fuel pump bracket. Place hardware back on bracket after removing bracket from frame/mount.

- h. Remove one screw, flat and lock washer (3, Figure 4-18) (SICPS) securing fuel pump bracket (1) to generator mount (8), or one bolt, flat and lock washer, and spacer (JTACS and WIN-T) securing fuel pump bracket (1) to isolator mount.
- i. Remove four hex-head socket screws (20, Figure 5-24) and spacers (19) securing alternator to isolator mount (JTACS and WIN-T only).

CAUTION

Prior to removing the bolts that secure the unit to the frame, ensure the lifting device is attached to lifting eyes in order to prevent damage to equipment or serious injury to personnel.

NOTES

- The four spacers are located between frame and alternator. They are not accessible until unit is removed from frame.
- Ensure 24 VDC to starter is disconnected (para 4.37.) and AC output is disconnected before removing APU from frame assembly.

- j. Secure lifting device to lifting eyes (5 and 6).
- k. (SICPS) remove four bolts, flat and lock washers (5) securing APU (9) to resilient mounts (6).
- l. (JTACS and WIN-T) remove two bolts, flat washers (26) and lock nuts (29) securing APU to vibration isolator mount (28)

WARNINGS

DO NOT stand or sit on the generator as it is being hoisted, lowered, or transported.

DO NOT lift the generator over personnel.

When using lift ring, ensure that a closed ring with safety latch is used. NO OPEN HOOKS are to be used when lifting APU.

Lift ring must have a swivel attached to prevent equipment from swinging.

Hard hats must be worn when APU is removed by overhead lift ring.

- m. Lift APU (9) off resilient mounts (6) or vibration isolator mount (18), and set on surface where there is support for generator brackets (8) and engine brackets (7).

CAUTION

Avoid blocking unit using the oil pan located beneath unit. Ensure unit is blocked using alternator space in front of oil pan and alternator to avoid damage to equipment.

- n. (SICPS) use lifting device to set generator brackets (8) and engine brackets (7) on resilient mounts (6).
- o. (JTACS and WIN-T) Align spacers (19) over installation holes on isolator mount (18). Using lifting device, place and align APU over spacers. Slowly lower unit to frame and carefully adjust APU over spacers as needed.

NOTE

Once APU is correctly aligned over spacers, APU can be secured to isolator mount. Hardware is installed beneath isolator mount.

- p. (JTACS and WIN-T) Secure alternator to isolator mount (18) with four hex-head socket screws (20).
- q. (JTACS and WIN-T) secure generator (10) brackets to vibration isolator mount (18) with two bolts, flat washers and lock nuts; and secure engine brackets (9) to vibration isolator mount (20) with four allen screws and lock washers.
- r. (SICPS) Secure generator brackets (8) and engine brackets (7) on resilient mounts (6).
- s. Remove lifting device from lifting eyes (5 and 6).
- t. Install 24 VDC to starter and reconnect AC output.
- u. Install fuel pump bracket (1, Figure 4-18) to generator mount (8) (SICPS) with one screw, flat and lock washer (3), or to isolator mount (JTACS and WIN-T) with one bolt, flat and lock washer.

- v. (JTACS and WIN-T) Install fuel hose clamp (32, Figure 5-24) to isolator mount with one bolt, flat and lock washer (31) and hex nut (33).
- w. Install fuel day tank assembly to frame with four bolts, flat and lock washers (9, Figure 4-19) (JTACS and WIN-T), or four bolts and flat washers (5, Figure 4-20) (SICPS).
- x. Install ground strap (7, Figure 4-42) to frame with one bolt, flat washer and lock washer (8).
- y. Install radiator (1, Figure 4-6) on radiator mount (5), and secure with two bolts, lock washers, rubber washers, flat washers, and nuts.
- z. Install radiator support bracket to frame and radiator with two screws, flat and lock washers (15, Figure 4-5), two screws (JTACS), or two slotted hex-head screws (SICPS and WIN-T), flat and lock washers (17).
- aa. Install air intake pipe to turbo charger with two nuts and lock washers (1, Figure 4-35) (JTACS), or two bolts (SICPS and WIN-T).
- ab. Service radiator with coolant (para 4.19.).

REPAIR

NOTE

If repairing JTACS (MODEL MEP-903B) or WIN-T (MODEL MEP-903C) frame assembly, proceed to step b.

- a. To repair SICPS (MODEL MEP-903A) frame assembly (10), proceed as follows:
 - (1) Remove eight screws, lock washers, and washers (12) and remove two engine vibration mounts (11).
 - (2) Remove eight screws, lock washers, and washers (13) and remove two generator vibration mounts (14).
 - (3) Remove eighteen screws (16) and remove two runners (15).
 - (4) Install two runners (15) and secure with eighteen screws (16).
 - (5) Install two generator vibration mounts (14) and secure with eight screws, lock washers, and washers (13).
 - (6) Install two engine vibration mounts (11) and secure with eight screws, lock washers, and washers (12).
- b. To repair JTACS (MODEL MEP-903B) or WIN-T (MODEL MEP-903C) APU frame assembly (17), refer to Figure 5-24 (sheet 4 and 5) and proceed as follows:
 - (1) Remove ten hex-head bolts (30), flat and lock washers securing isolator mount assembly (18) to frame.
 - (2) Remove four screws, washers, and lock washers (21) and remove two pull handle brackets (22 and 24) and pull handle (23).

- (3). Install pull handle brackets (22 and 24) and pull handle (23) and secure with four screws, washers, and lock washers (21).
 - (4) Install vibration isolator mount assembly (18) to frame with ten hex-head bolts (30), flat and lock washers.
- c. To repair APU Vibration Isolator Mount Assembly (18), refer to Figure 5-24 (sheet 6) and proceed as follows:

NOTE

There are a total of 40 screws securing both top and bottom isolator mount plates to isolator mount assembly.

- (1) Remove 20 countersunk screws (37) securing top isolator mount plate (36) to isolator mount
- (2) Remove two screws and flat washers (41) securing coupling plate (40) to top isolator mount plate (36).

NOTE

Each coil is attached to bottom plate with two screws. Remove screws as necessary for each coil being replaced.

- (3) Remove two screws (37) securing coil (38) to bottom plate (39).
- (4) Install coil (38) to bottom plate (39) with two screws (37).
- (5) Install plate (40) to top isolator mount plate (36) with two screws and flat washers (41).
- (6) Install top isolator mount plate (36) to isolator mount assembly (18) with 20 screws (37).

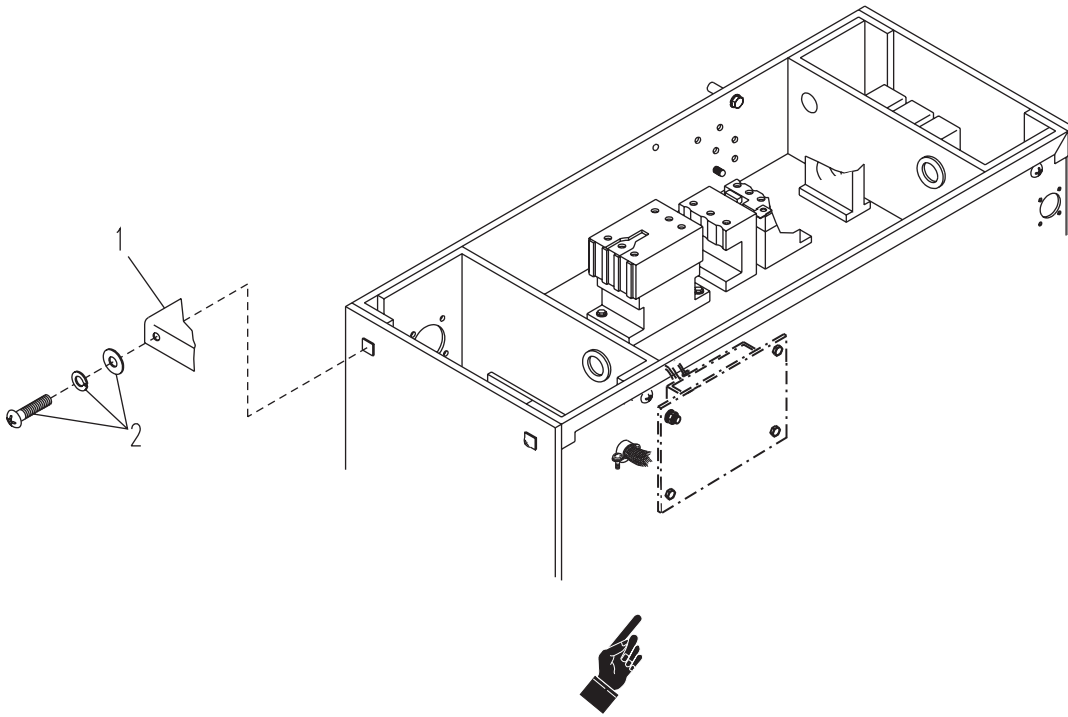

Figure 5-24. Frame Assembly and Vibration Isolator Mount Assembly (Sheet 1 of 6)

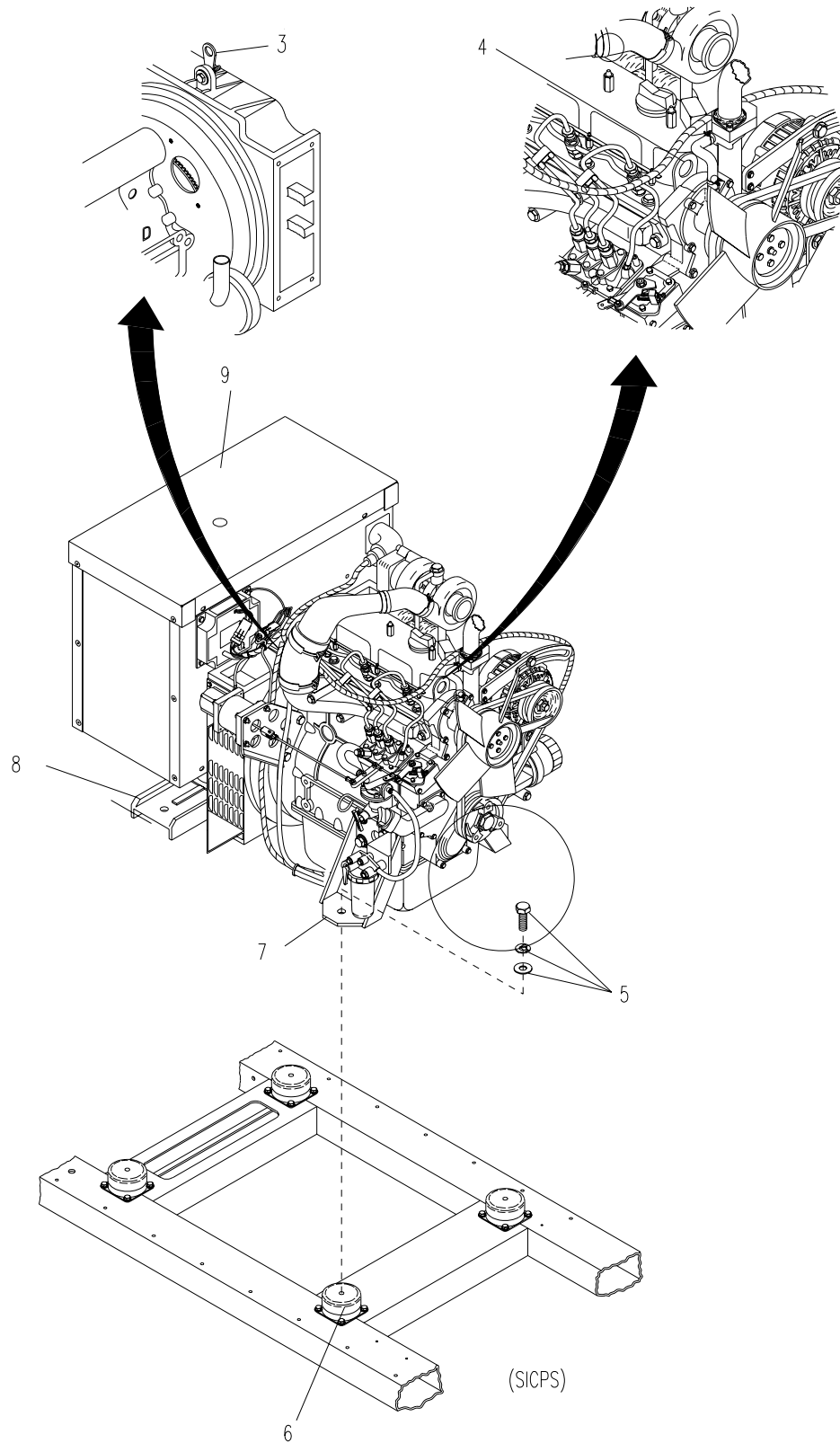

Figure 5-24. Frame Assembly and Vibration Isolator Mount Assembly (Sheet 2 of 6)

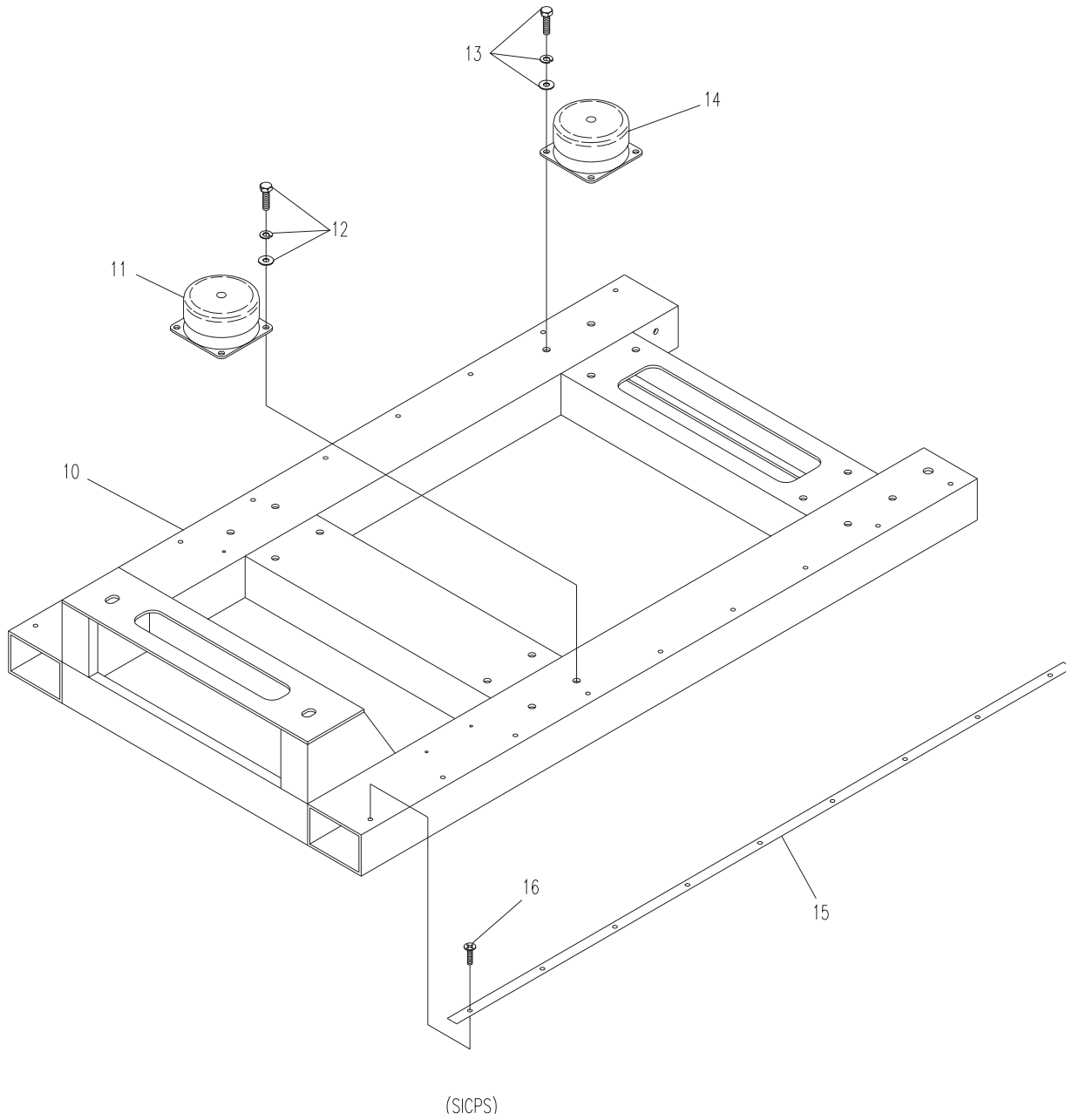
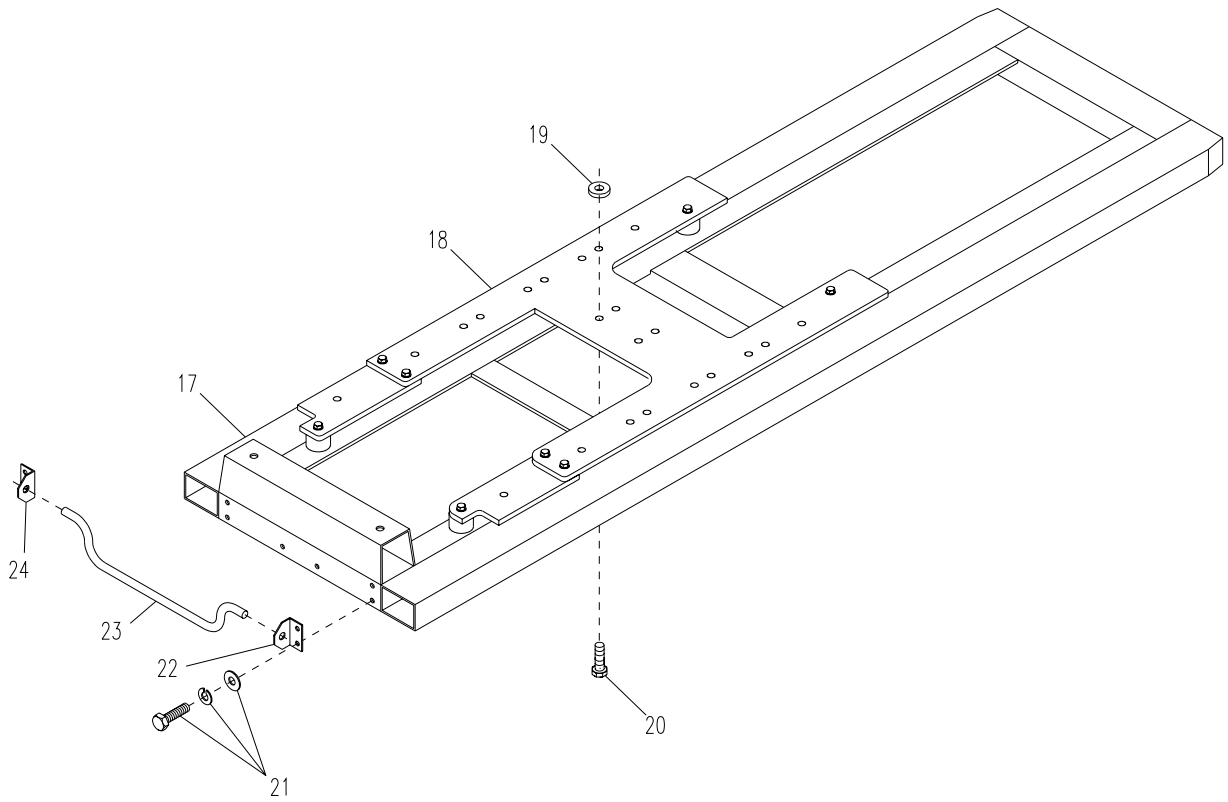

Figure 5-24. Frame Assembly and Vibration Isolator Mount Assembly (Sheet 3 of 6)



(WIN-T, JTACS)

Figure 5-24. Frame Assembly and Vibration Isolator Mount Assembly (Sheet 4 of 6)

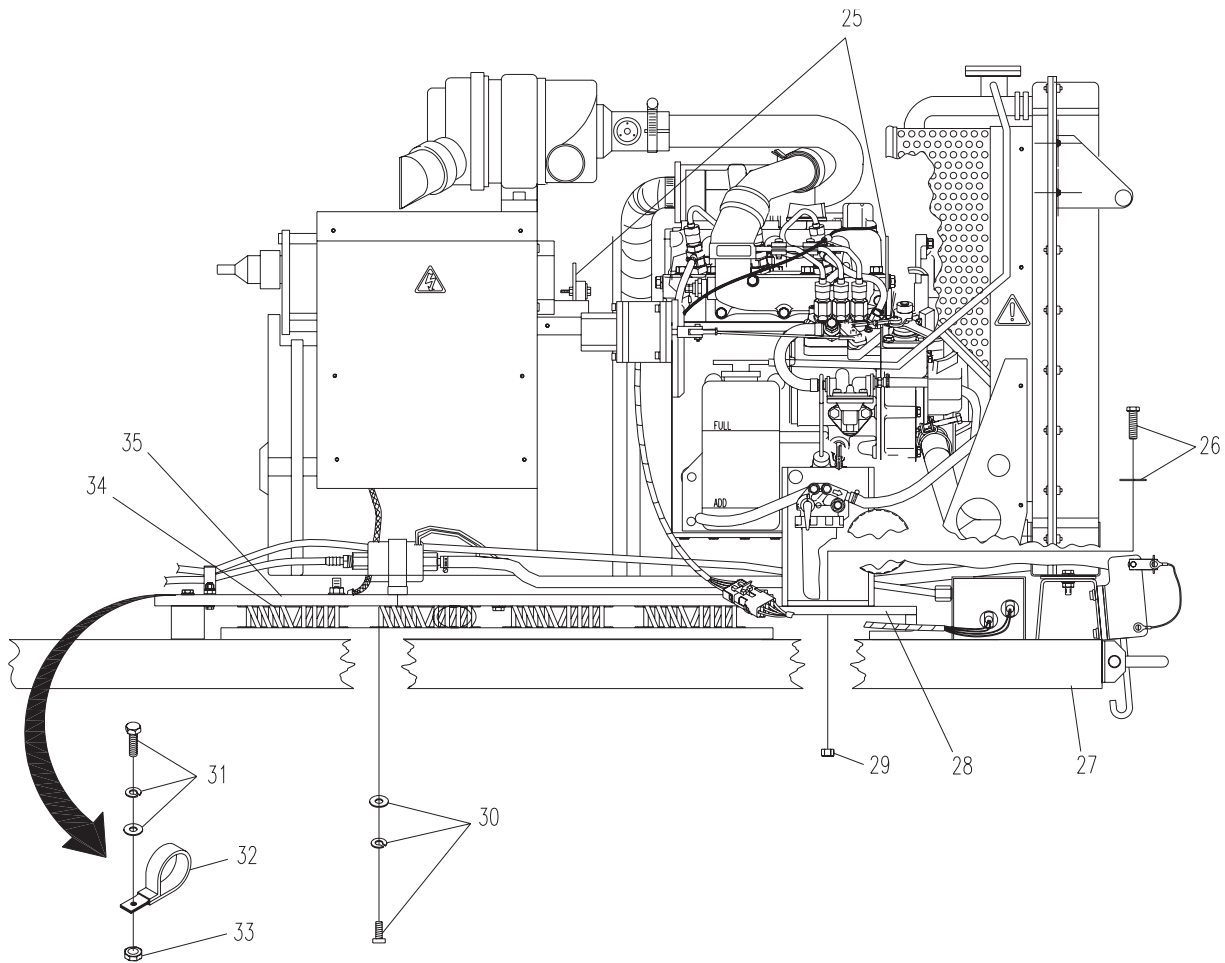

Figure 5-24. Frame Assembly and Vibration Isolator Mount Assembly (Sheet 5 of 6)

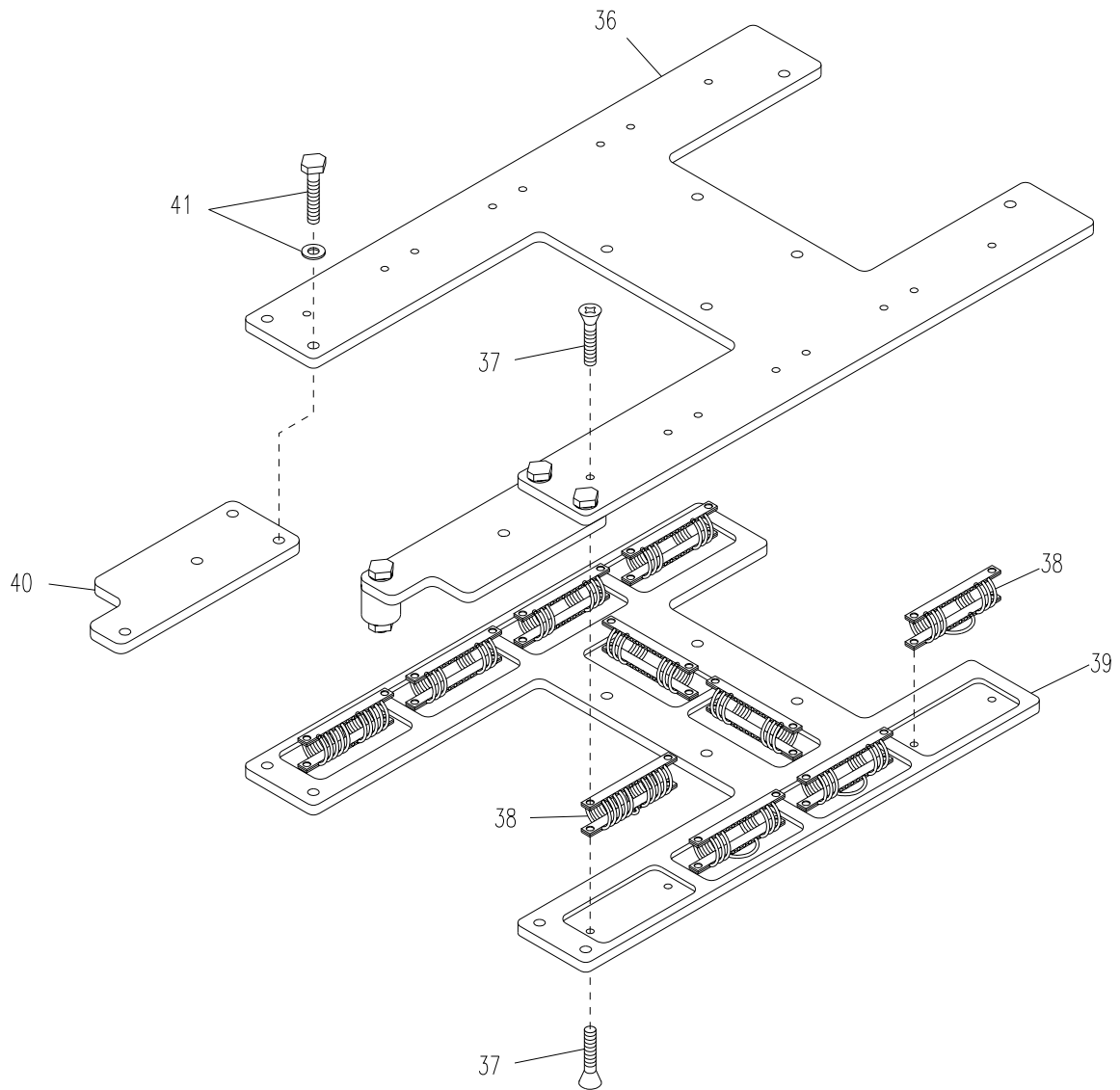

Figure 5-24. Frame Assembly and Vibration Isolator Mount Assembly (Sheet 6 of 6)

5.33. DIESEL ENGINE.

This task covers: a. Test b. Replace c. Install

INITIAL SETUP

Tools

General Mechanic's Tool Kit
(Item 1, Appendix B)

Torque Wrench
(Item 2, Appendix B)

Shop Equipment, Semitrailer Mounted
Electrical Repair
(Item 3, Appendix B)

Flywheel Puller
(Item 6, Appendix B)

Diesel Engine Compression Tester
(Item 11, Appendix B)

24 Vdc Battery
(Item 20, Appendix B)

Materials/Parts

Diesel Engine
or
Frame Assembly (WIN-T)

Personnel Required

Two

TEST

- a. Install diesel engine compression tester (1, Figure 5-25) into nozzle holder hole (2) on a cylinder.
- b. Ensure that speed control lever is set at stop position.
- c. Start engine with 24 VDC battery. Proceed as follows:

WARNING

Batteries contain explosive gas. ALWAYS make jumper connections at battery FIRST, then at starter. Failure to heed this warning could cause severe injury or DEATH.

- (1) Connect jumper lead from post of battery to starter solenoid positive binding post.
- (2) Connect second jumper to the battery negative post and touch starter body with jumper lead.

- d. Read compression pressure and stop engine. Compression pressure should read between 412 and 469 psi (2.84 and 3.24 MPa).
- e. Repeat steps a - d to ensure an accurate reading.
- f. Test remaining cylinders repeating steps a - d.

NOTE

The lowest allowable limit is 327 psi (2.26 MPa). If compression pressure is below allowable limit, test the cylinder (para 6.30.), piston ring (para 6.24.), valve clearance (para 5.37.), valves (para 6.7.), and cylinder head (para 6.5.).

NOTE

Variance between cylinders should be under 10%.

NOTE

If conditions are not met, refer to next higher level of maintenance.

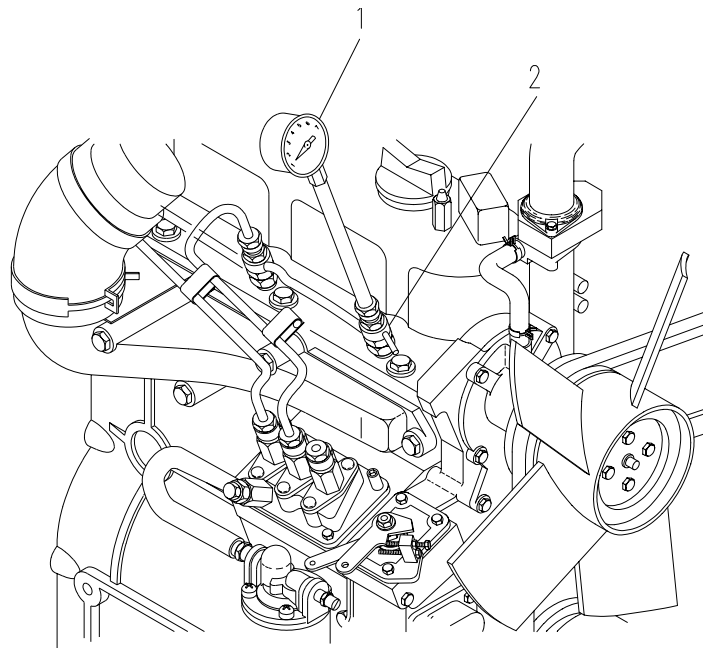

Figure 5-25. Diesel Engine (Sheet 1 of 11)

REPLACE

WARNING

A heavy lifting device and two personnel are required to lift the diesel engine on and off the frame. The diesel engine weighs 139 pounds (62 kg). A lifting device with lifting capacity of 500 pounds (1100 kg) is required to lift the diesel engine. DO NOT use a lifting device with lifting capacity of less than 500 pounds (1100 kg). Failure to observe this warning could result in damage to equipment, serious injury to personnel, or DEATH.

WARNING

Ensure that the APU DC power supply is disconnected. Failure to observe this warning could result in damage to equipment, serious injury to personnel, or DEATH.

WARNING

Ensure that the APU is turned off and completely de-energized before opening generator housing. Failure to observe this warning could result in damage to equipment, serious injury to personnel, or DEATH.

- a. Loosen two clamps (17), (Figure 4-22 SICPS) or (Figure 4-23 JTACS and WIN-T) and remove fuel line (18) from between day tank (16) and fuel filter (15).
- b. Loosen two clamps (23) and remove fuel line (24) from between injection nozzles (8) and day tank (16).
- c. Disconnect P1 from J1.
- d. Disconnect P8 from J8.
- e. Disconnect P5 from J5.
- f. Disconnect P4 from J4.
- g. Disconnect P7 from J7.
- h. Disconnect P6 from J6.

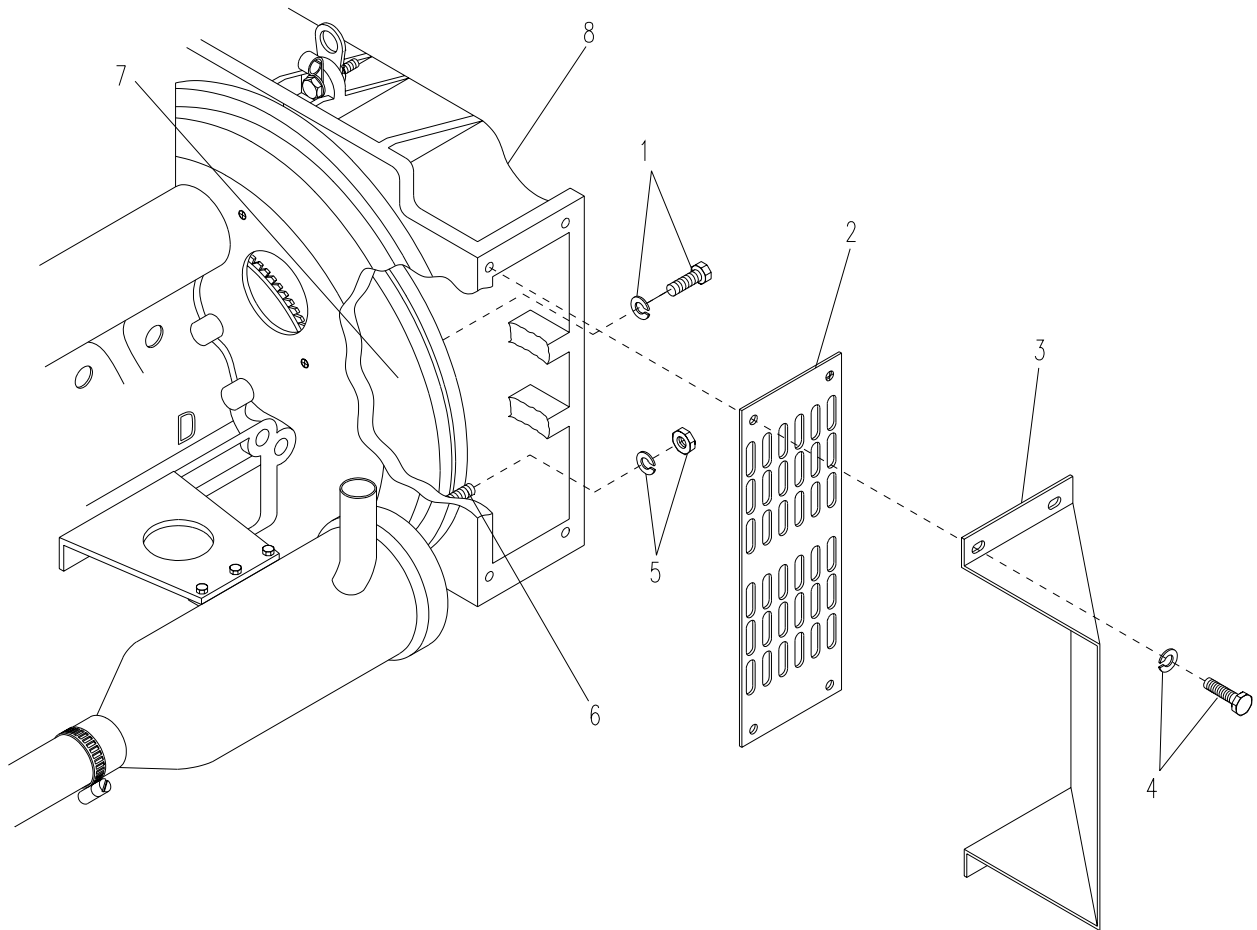

Figure 5-25. Diesel Engine (Sheet 2 of 11)

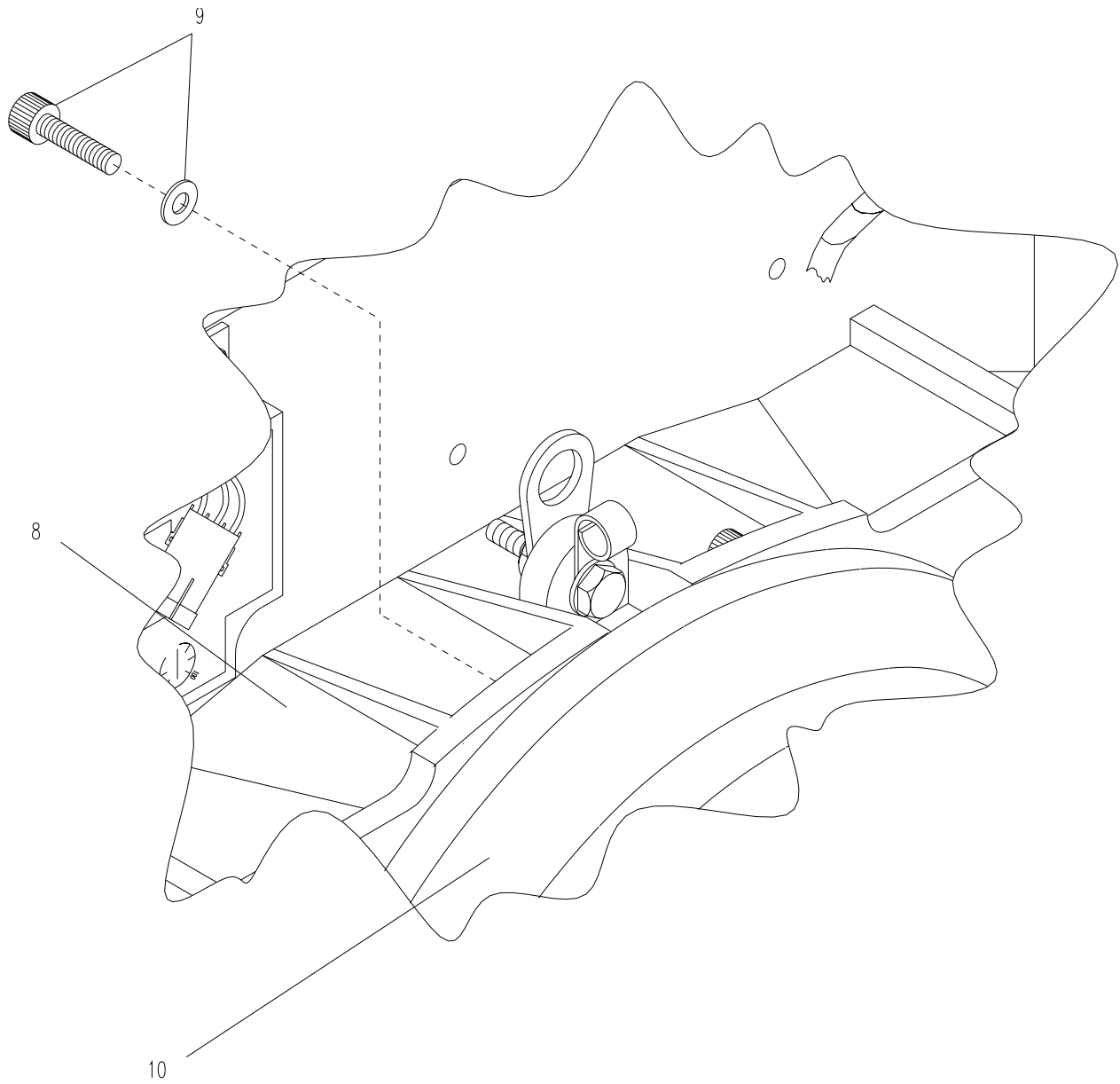

Figure 5-25. Diesel Engine (Sheet 3 of 11)

- i. Disconnect all wiring harness connections from engine.

NOTE

Hold wiring harness for connection to new engine.

- j. At generator coupling remove one bolt (12, Figure 5-20), washer (11), nut (7), lock washer (8), lifting eye (9), and wire clamp (10).
- k. Install lifting eye to threaded hole on generator engine cylinder head.

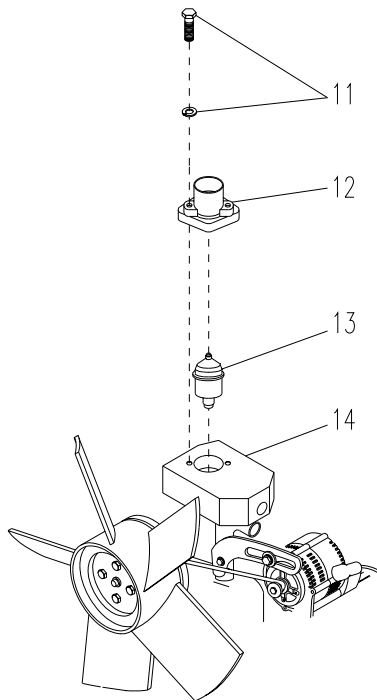

Figure 5-25. Diesel Engine (Sheet 4 of 11)

- I. Remove eight bolts and lock washers (4), two generator air deflectors (3), and two generator grills (2) (Figure 5-25, Sheet 2).

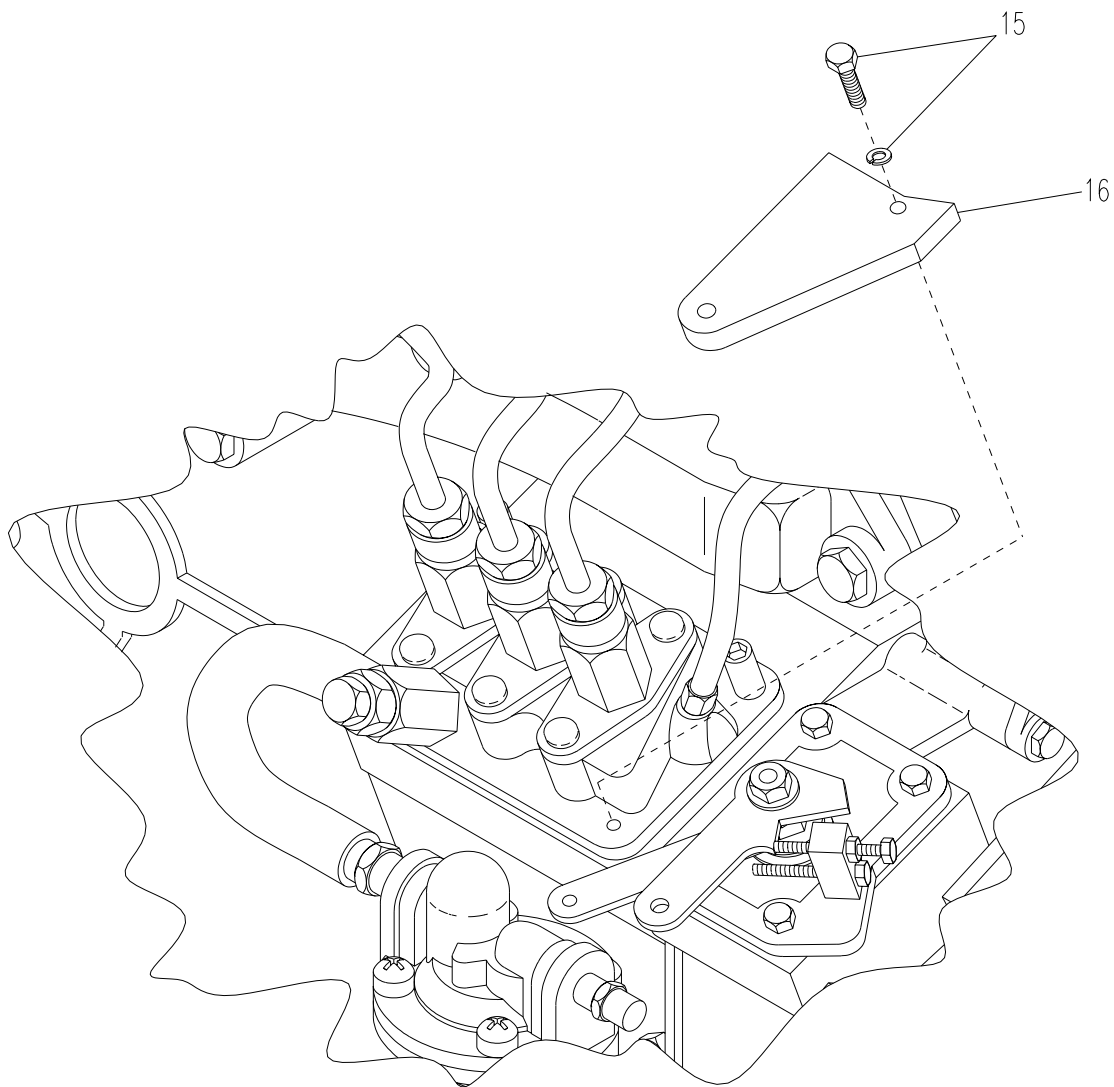

Figure 5-25. Diesel Engine (Sheet 5 of 11)

m. Remove resilient mount bracket support (7) and generator bracket (6) (Figure 4-5, STEPS a and c).

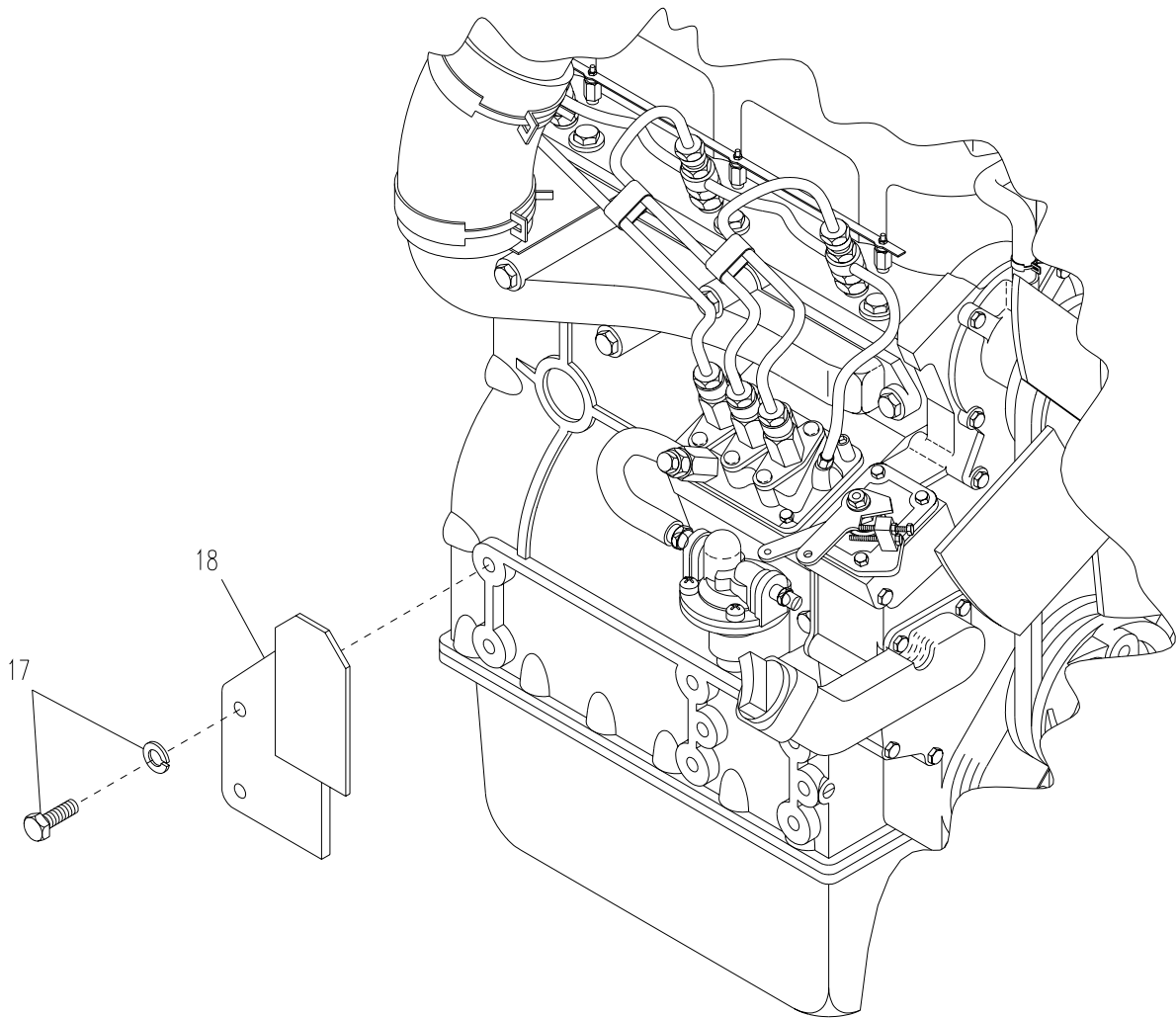

Figure 5-25. Diesel Engine (Sheet 6 of 11)

n. Connect hoist and chain to lifting eyes located on engine.

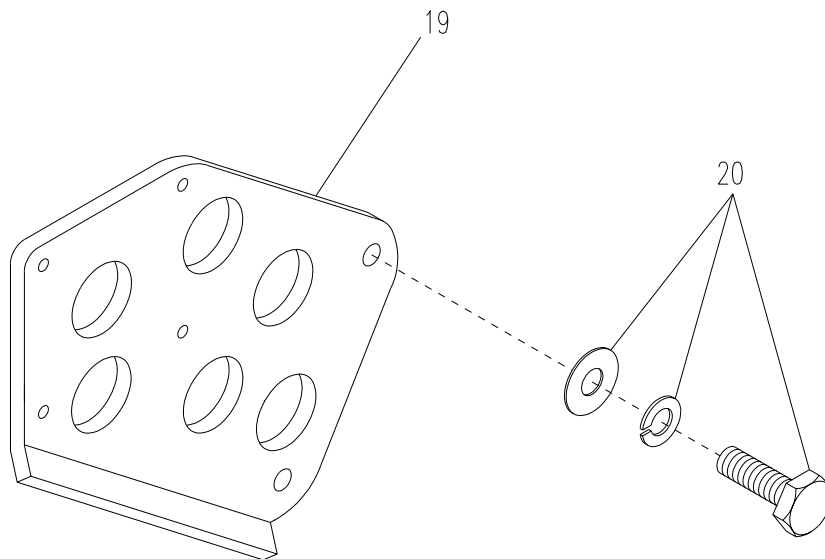

Figure 5-25. Diesel Engine (Sheet 7 of 11)

- o. Lift engine/generator mule.
- p. On generator exterior bottom remove two hex head socket bolts (SICPS, two hex head bolts) and lock washers (9), securing generator couplings (8), to bell housing (10) (Figure 5-25).

WARNING

Do not use oil pan located at bottom of generator to block generator set. Failure to heed this warning could result in severe damage to equipment or injury to personnel.

- q. Lower engine/generator mule on to suitable support system.
- r. Reach inside generator air vent and remove six screws and lock washers (1), (Figure 5-25) securing generator to flywheel adapter (7).

NOTE

Rotate engine to access hidden bolts using crankshaft pulley nut.

- s. On generator exterior, remove two socket head screws (SICPS, two hex head bolts and washer) and lock washers (9) from top securing generator coupling (8) to bell housing (10).

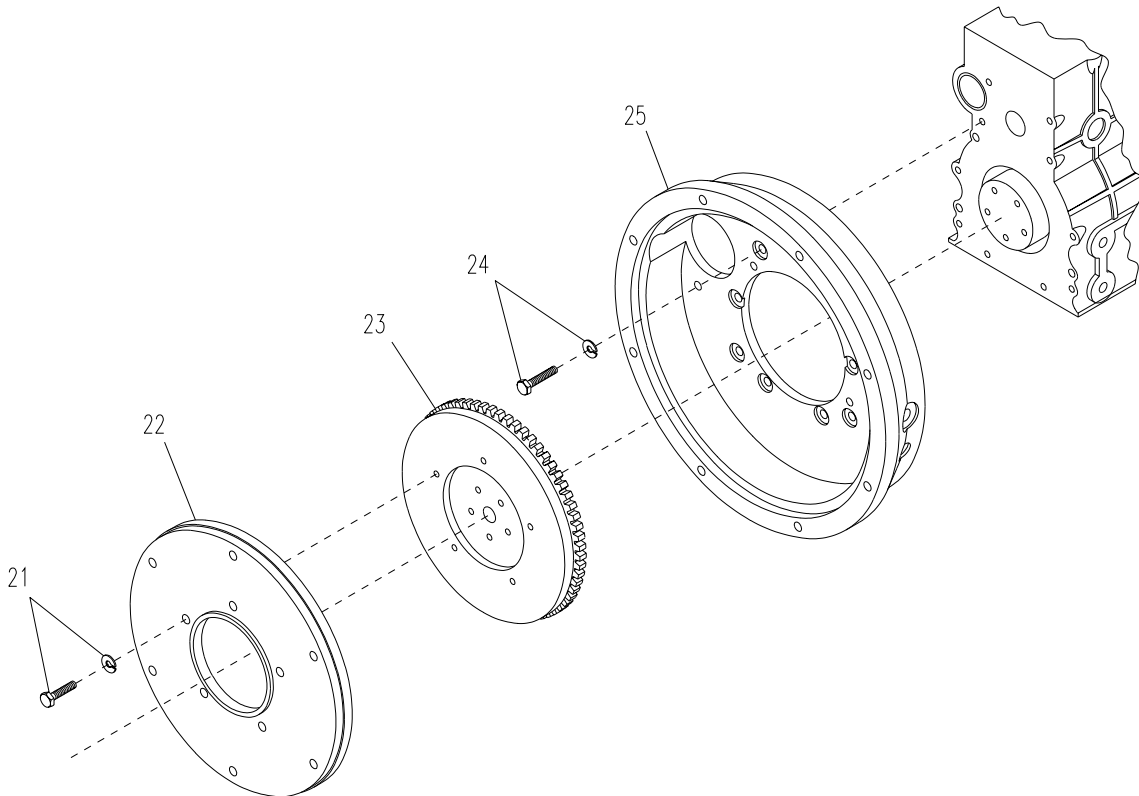

Figure 5-25. Diesel Engine (Sheet 8 of 11)

- t. Reach inside generator air vents and remove four nuts and lock washers (JTACS and WIN-T) (SICPS – hex head bolts and lock washers) (5) from four studs (6) (two on each side of APU) securing generator coupling (8) to bell housing (10).

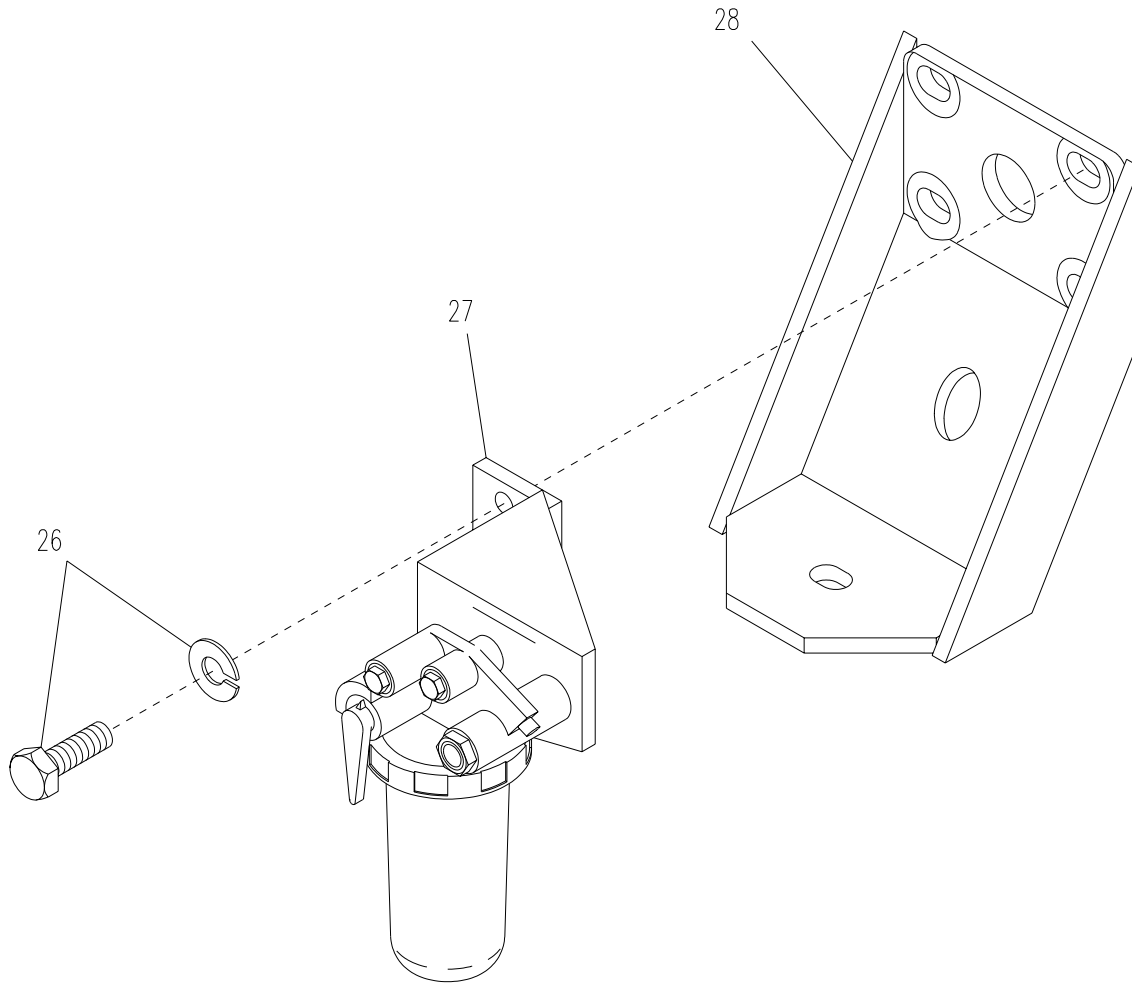

Figure 5-25. Diesel Engine (Sheet 9 of 11)

u. Using lifting device, remove diesel engine from generator.

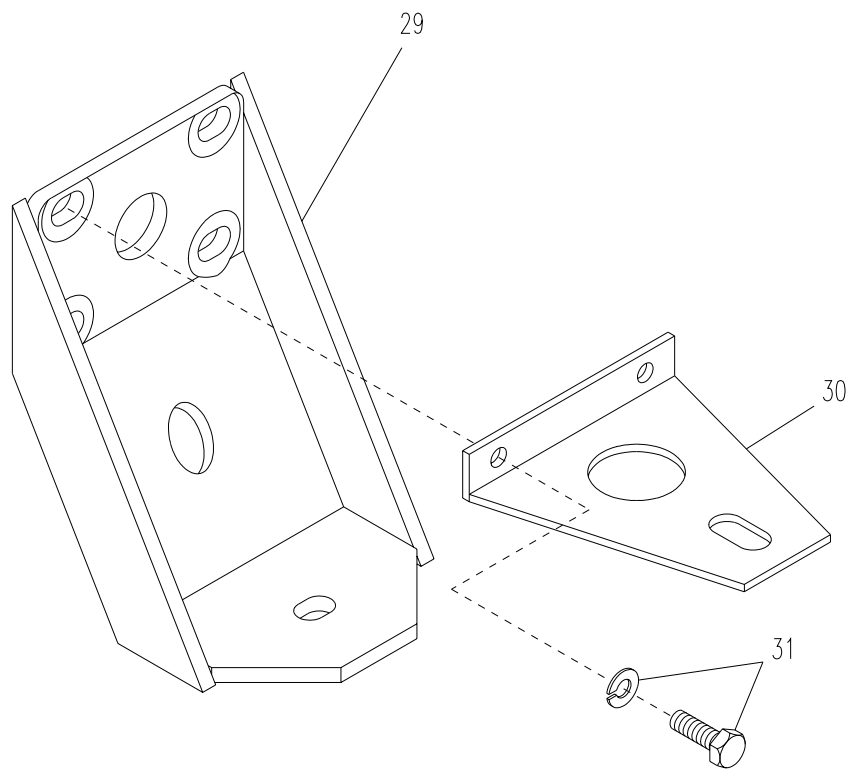

Figure 5-25. Diesel Engine (Sheet 10 of 11)

- v. Remove five bolts and lock washers (21) (Figure 5-25, Sheet 8) and flywheel adapter (22) from old engine.
- w. Mark the flywheel (23) and bolt (24) (Figure 5-25, Sheet 8) holding bell housing (25) to engine.
- x. Use socket or box end wrench on bolt on crankshaft pulley to prevent the flywheel (3, Figure 5-30) from turning.

CAUTION

Flywheel must be reinstalled with the timing marks/ flywheel at the exact same relative position to the crankshaft as the flywheel was when removed.

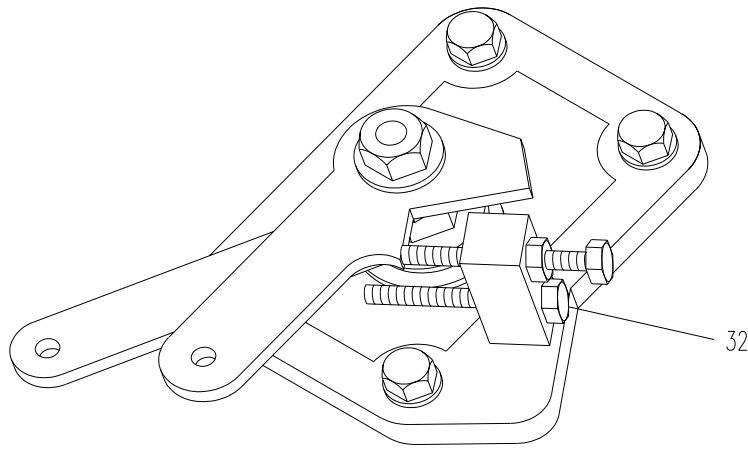

Figure 5-25. Diesel Engine (Sheet 11 of 11)

- y. Remove flywheel from old engine (refer to para 5.38., REPLACE steps a through d).
- z. Remove flywheel from new engine (refer to para 5.38., REPLACE steps a through d).
- aa. Remove eight bolt and lock washers (24) and bell housing from old engine.
- ab. Remove eight bolts and lock washers, and plate from old engine.

INSTALL

- a. Install plate on old engine and secure with eight bolts and lock washers.
- b. Install old flywheel on old engine (refer to para 5.38., REPLACE steps e through g).

CAUTION

Flywheel must be reinstalled with the timing marks/ flywheel at the exact same relative position to the crankshaft as the flywheel was when removed.

- c. Align timing marks on new flywheel (23) and bell housing (25). Install new flywheel (23) on new engine (refer to para 5.38., REPLACE steps e through g).

- d. Install flywheel adapter (22) on new engine with five bolts and lock washers (21, Figure 5-25, Sheet 8).
- e. On new engine, use adjusting screw (32) to move throttle to fully open position.
- f. Secure lift hook to lifting eyes on new engine.
- g. Align studs (6) on bell housing (10) and holes in generator coupling (8). Install engine to generator.
- h. Reach inside generator air vents and secure generator coupling (8) to bell housing (10) with four nuts and lock washers, JTACS and WIN-T (SICPS-hex head bolts and lock washers) (5) on four studs (6) (two on each side of APU).
- i. On generator exterior, secure generator coupling (8) to bell housing (10) with two socket head screws (SICPS-two hex head bolts and washers) and lock washers (9).
- j. On generator exterior bottom, secure generator coupling (8) to bell housing (10) with two socket head screws (SICPS-two hex head bolts and washers) and lock washers (9).
- k. Secure generator to flywheel adapter (7) with six screws and lock washers (1). Torque between 28.9 and 33.3 ft-lbs (32.9 and 45.1 Nm).
- l. Install two generator grills (2) and air deflectors (3) with eight bolts and lock washers (4).
- m. Install resilient mount bracket support (7) and generator bracket (6, Figure 4-5, STEP a and c).
- n. Install SICPS muffler (refer to para 4.41., REPLACE steps c through f; Figure 4-29).
- o. Install JTACS and WIN-T muffler (refer to para 4.40., REPLACE steps c through g; Figure 4-28).
- p. At generator coupling, install one wire clamp (10, Figure 5-20), lifting eye (9), lock washer (8), nut (7), washer (11) and bolt (12).
- q. Refer to para 4.22. and remove two bolts and lock washers (11), thermostat cover (12), thermostat (13), and temperature sender block (14) from old engine. Discard thermostat (13) and thermostat cover (12).
- r. Remove thermostat cover and thermostat from new engine. Install temperature sender block (14) from old engine to new engine.
- s. Install new thermostat (13) and thermostat cover (12) on temperature sender block (14) and secure with hardware from old engine.
- t. Remove one bolt and lock washers (15, Figure 5-25) and pivot arm bracket (16) from old engine. Install bracket on new engine.
- u. Remove two bolts and lock washers (17) and radiator overflow tank bracket from old engine. Install bracket on new engine.
- v. Remove two screws, flat washers, and lock washers (20) and remove actuator/solenoid bracket (19) from old engine. Install bracket on new engine.

- w. Remove four bolts and lock washers (26), fuel filter bracket (27), and engine mount (28) from old engine. Install bracket and mount on new engine.
- x. Remove four bolts and lock washers (31), muffler bracket (30), and remaining engine mount (29) from old engine. Install bracket and mount on new engine.
- y. Reconnect blade terminal.
- z. Reconnect P6 to J6.
- aa. Reconnect P7 to J7.
- ab. Reconnect P4 to J4.
- ac. Reconnect P5 to J5.
- ad. Reconnect P8 to J8.
- ae. Reconnect P1 to J1.
- af. Install fuel line (24, Figure 4-22 SICPS or Figure 4-23 JTACS and WIN-T) between injection nozzles (8) and day tank (16). Secure with two clamps (23).
- ag. Install fuel line (18, Figure 4-22 SICPS or Figure 4-23 JTACS and WIN-T) between day tank (16) and fuel filter (15). Secure with two clamps (17).
- ah. Remove lift ring.
- ai. Install the following items on the new diesel engine:
 - (1) Generator 10 kW to APU frame (para 5.24.).
 - (2) Wiring Harness P1 (para 5.27.).
 - (3) Exhaust pipe (JTACS and WIN-T, para 4.40.; SICPS, para 4.41.).
 - (4) Radiator overflow tank (para 4.28.).
 - (5) Radiator hoses (para 4.24.).
 - (6) Fuel lines and fittings (para 4.35.).
 - (7) Temperature sender (para 4.25.).
 - (8) Temperature switch (para 4.26.).
 - (9) Actuator/Solenoid (para 4.49.).
 - (10) Actuator Linkage (para 4.50.).

5.34. EXHAUST MANIFOLD.

This task covers: Replace

INITIAL SETUP

Tools

General Mechanic's Tool Kit
(Item 1, Appendix B)

Torque Wrench
(Item 2, Appendix B)

Materials/Parts

Exhaust Manifold

Exhaust Manifold Gasket
(Item 3, Appendix J)

Equipment Condition

Engine turbocharger removed (para 4.44.).

REPLACE

- a. Remove three nuts (5, Figure 5-26), bolts (6), exhaust manifold (4) and manifold gasket (3).
- b. Refer to Figure 5-26 for proper sequence and install manifold gasket (3) and exhaust manifold (4) on mounting studs (2), using three nuts (5) and three bolts (6). Torque between 13.0 and 15.2 ft-lbs (17.7 and 20.6 Nm).

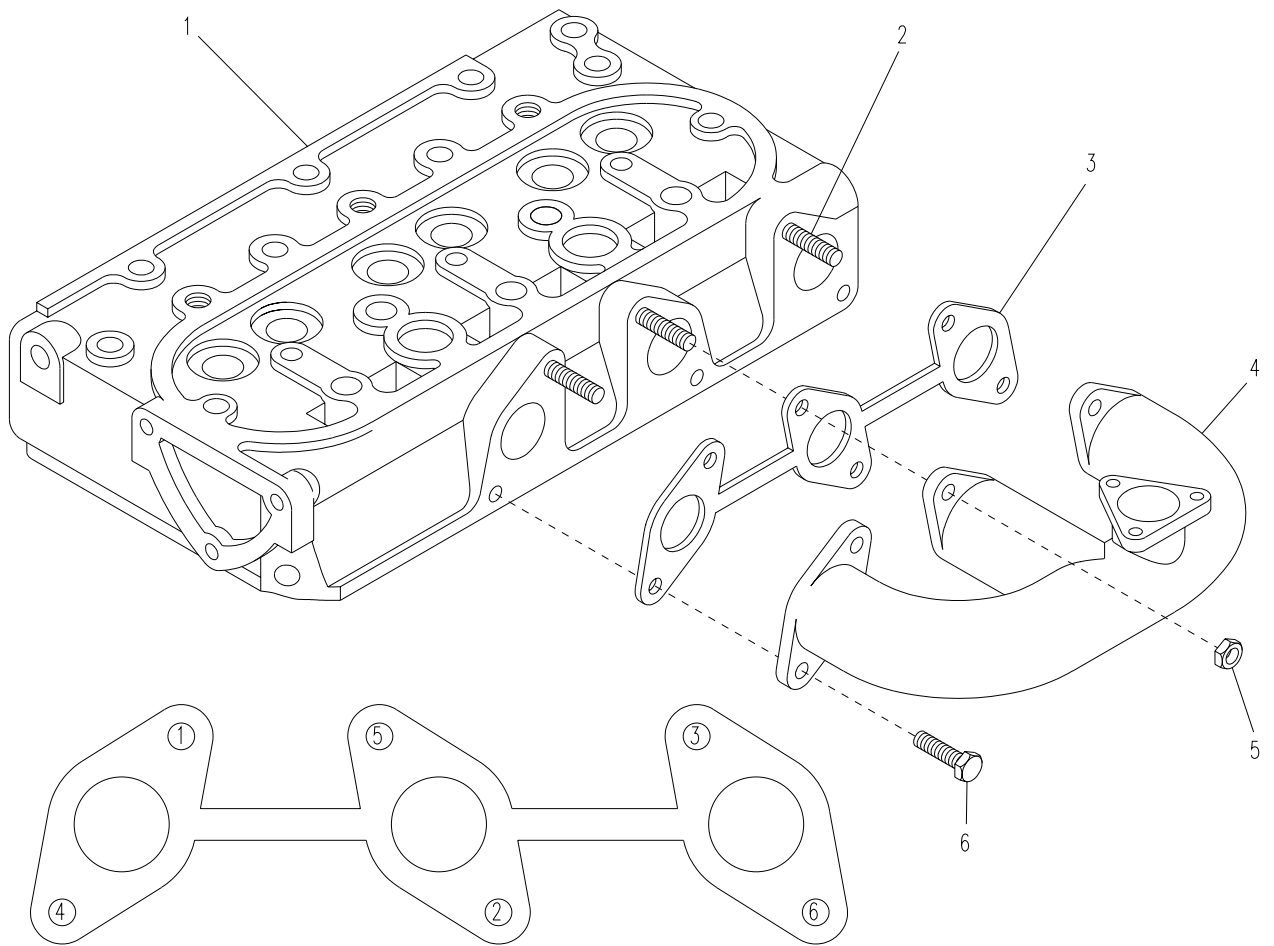

Figure 5-26. Exhaust Manifold

5.35. INTAKE MANIFOLD.

This task covers: Replace

INITIAL SETUP

Tools

General Mechanic's Tool Kit
(Item 1, Appendix B)

Equipment Condition

Air intake pipe removed (para 4.47.).
Manifold glow plug removed (para 4.38.).
Injection pumplines removed (para 5.14.).

Materials/Parts

Intake Manifold

Intake Manifold Gasket
(Item 6, Appendix J)

REPLACE

- a. Loosen four clamps (2 and 5, Figure 5-27) and remove hoses (3 and 6) and elbow (4).

NOTE

Observe position of bolts (9), (10), and (11) prior to removal to ensure correct position during installation.

- b. Remove two bolts (11), two bolts (10), two bolts (9), intake manifold (1), and manifold gasket (8).
- c. Install new manifold gasket (8) and intake manifold (1) and secure with two bolts (9, 10 and 11).
- d. Install two intake hoses (3 and 6) and intake elbow (4) and secure with four clamps (2 and 5).

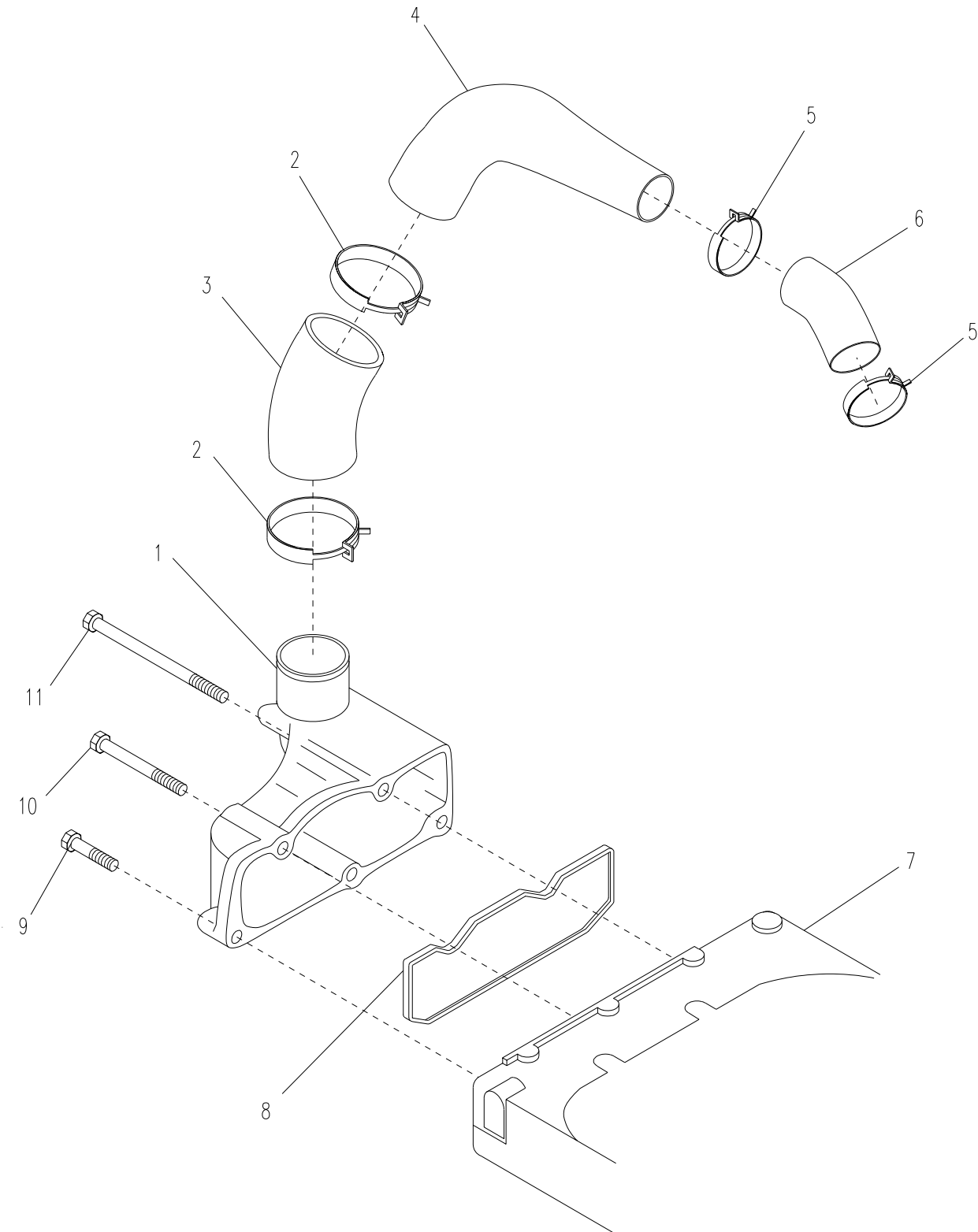

Figure 5-27. Intake Manifold

5.36. ROCKER ARM ASSEMBLY.

This procedure covers: a. Test b. Repair c. Replace

INITIAL SETUP

Tools

General Mechanic's Tool Kit
(Item 1, Appendix B)

Inside Micrometer Caliper
(Item 42, Appendix B)

Outside Micrometer Caliper
(Item 43, Appendix B)

Torque Wrench
(Item 2, Appendix B)

Equipment Conditions

Remove the air filter cleaner tube assembly.

Valve head cover removed (para 4.64.).

MASTER ON/OFF switch on APU controller set to OFF.

Materials/Parts

Rocker Arm Assembly

TEST

- a. Remove rocker arm assembly (steps a - b of REPLACE).
- b. Disassemble rocker arm assembly:
 - (1) Remove one bolt, thrust spring, lock washer, and flat washer (1, Figure 5-28) from end of rocker arm assembly.
 - (2) Remove first rocker arm (2), rocker arm bracket (3), second rocker arm (5), and first rocker arm spring (6) from rocker arm shaft (7).
 - (3) Repeat step 2 for remaining rocker arms, brackets, and spring.
- c. Use inside micrometer caliper to measure the inside diameter (ID) of the first rocker arm (2). ID should be between 0.41339 in. (10.5 mm) and 0.41410 in. (10.518 mm).
- d. Use outside micrometer caliper to measure the outside diameter (OD) of the rocker arm shaft (7). OD should be between 0.41233 in. (10.473 mm) and 0.41276 in. (10.484 mm).
- e. Calculate oil clearance. Oil clearance should be between 0.00063 and 0.00177 in. (0.016 and 0.045 mm).
- f. If oil clearance exceeds allowable limit, replace rocker arm.
- g. Recalculate the oil clearance. If the oil clearance still exceeds allowable limit, replace rocker arm shaft.
- g. Repeat steps c - f for remaining rocker arms.

REPAIR

Repair rocker arm assembly by replacing rocker arms or shaft, as determined in TEST procedure.

REPLACE

NOTE

Always adjust valve clearance after removing or disassembling rocker arm assembly.

- a. Remove three nuts, lock washers, and washers (4) securing rocker arm assembly to mounting studs (8).
- b. Remove rocker arm assembly.
- c. Install rocker arm assembly on mounting studs (8).
- d. Secure rocker arm assembly to mounting studs (8) with three nuts, lock washers, and washers (4). Torque nuts between 7.23 and 8.32 ft-lbs (1.0 to 1.15 Nm).
- e. Refer to para 5.37 for adjusting valve clearances.

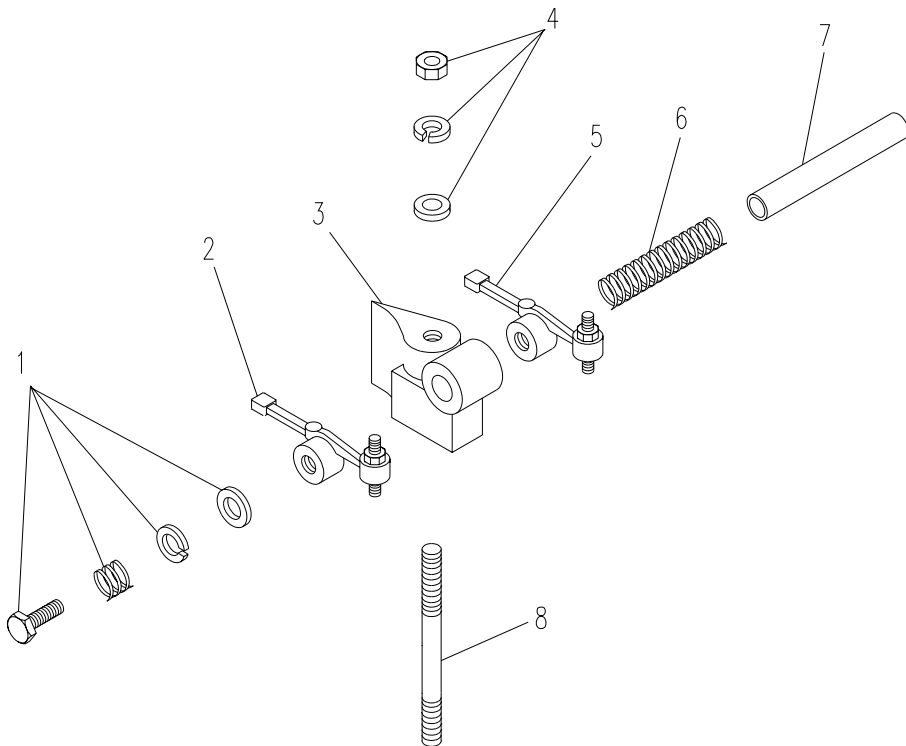

Figure 5-28. Rocker Arm Assembly

5.37. VALVE CLEARANCE.

This task covers: Adjust

INITIAL SETUP

Tools

General Mechanic's Tool Kit
(Item 1, Appendix B)

Materials/Parts

None

Equipment Conditions

Engine shut down and allowed to cool completely.

Generator assembly removed (para 5.24.).

Flywheel adapter removed (para 5.33., REPLACE, step o).

Valve cover removed (para 4.64.).

ADJUST

- a. Bring piston no. 1 to compression top dead center. Proceed as follows:

CAUTION

Use retaining nut on crankshaft pulley to turn crankshaft. Do not turn crankshaft by any other means.

- (1) Turn flywheel (1, Figure 5-29) until "1TC" (3) mark on flywheel (1) aligns with timing hole (2) in bell housing.

NOTES

- Looking directly at the flywheel, the timing hole is located above speed sensor mounting hole, at approximately two o' clock on the bell housing.
 - When the "1TC" mark on the flywheel aligns dead center with the timing hole on the bell housing, piston no. 1 is either in the compression top dead center or overlap top dead center position.
- (2) Rotate flywheel cw and ccw about 15° and observe intake and exhaust valves on piston no. 1. If intake and exhaust valves on piston no. 1 do not move while rotating flywheel, piston no. 1 is in compression position. Proceed to step b. If intake and exhaust valves move while rotating flywheel, piston is in overlap position. Proceed to step a(3).
- (3) Rotate flywheel 360°. Realign "1TC" mark on flywheel with timing hole on bell housing and repeat step a(2). Piston no. 1 should be in compression position.
- b. Refer to Figure 5-29 and use a feeler gauge to measure valve clearance (4) of intake and exhaust valves on piston no. 1, exhaust valve on piston no. 2, and intake valve on piston no. 3. Valve clearance (4) should measure between 0.0059 and 0.0073 in. (0.145 and 0.185 mm).
- c. If valve clearance (4) is out of tolerance, loosen lock on adjusting screw, and turn adjusting screw to adjust clearance.

- d. Bring piston no. 1 to overlap top dead center.

NOTE

Perform (1) and (2) of step a to bring piston no. 1 to overlap top dead center with the exception that you will observe for movement in the exhaust and intake valves in step (2).

- e. Refer to Figure 5-29 and use a feeler gauge to measure valve clearance of intake valve on piston no. 2 and exhaust valve on piston no. 3. Valve clearance should measure between 0.0059 and 0.0073 in. (0.145 and 0.185 mm).
- f. If valve clearance (4) is out of tolerance, loosen lock nut on adjusting screw and turn adjusting screw to adjust clearance.

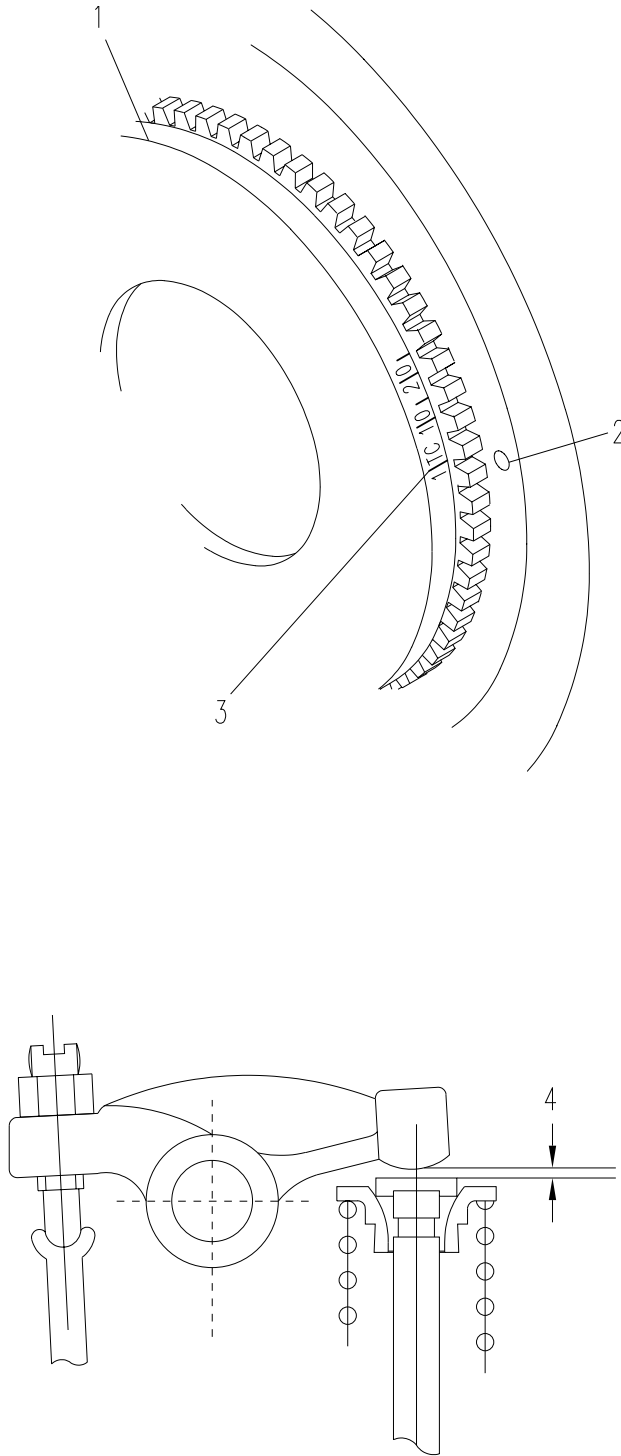

Figure 5-29. Valve Clearance

5.38. FLYWHEEL.

This task covers: Replace

INITIAL SETUP

Tools

General Mechanic's Tool Kit
(Item 1, Appendix B)

Flywheel Puller
(Item 6, Appendix B)

Flywheel Lock
(Item 46, Appendix B)

Materials/Parts

Lubricating Oil
(Items 10-13, Appendix F)

Flywheel

REPLACE

CAUTION

Flywheel must be reinstalled with the timing marks and flywheel at the exact same relative position to the crankshaft as the flywheel was when removed.

- a. Mark flywheel and bolt (24, Figure 5-25, sheet 8) holding bell housing to engine.
- b. Using an appropriate wrench on the crankshaft pulley nut, lock the flywheel (3, Figure 5-30) to prevent it from turning.

CAUTION

Do not use air wrench to remove or install flywheel bolts. Use of an air wrench may strip the thread requiring crankshaft replacement.

- c. Remove five bolts (1) securing flywheel (3) to crankshaft (4).
- d. Install flywheel puller and remove flywheel (3).
- e. Remove flywheel puller from flywheel (3).
- f. Apply lubricating oil to five bolts (1).
- g. Install new flywheel (3) and secure to crankshaft (4) with five bolts (1). Torque between 39.8 and 43.4 ft-lbs (53.9 to 58.8 Nm).
- h. Remove flywheel puller and flywheel lock.

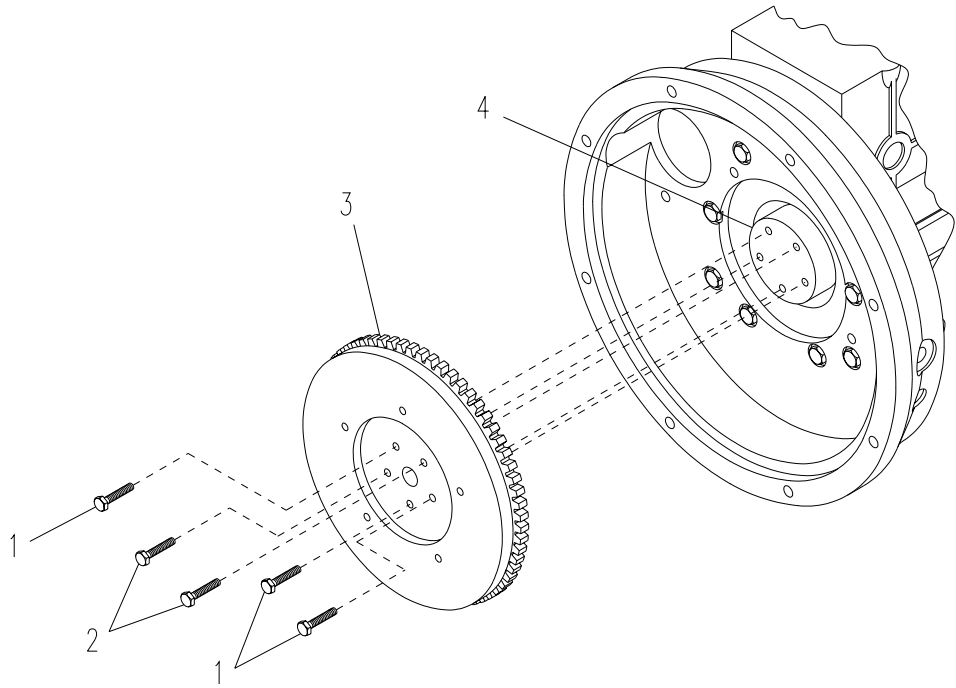

Figure 5-30. Flywheel

THIS PAGE INTENTIONALLY LEFT BLANK

CHAPTER 6

GENERAL SUPPORT MAINTENANCE INSTRUCTIONS

	Page
Section I. Repair Parts; Special Tools; Test, Measurement, and Diagnostic Equipment (TMDE); and Support Equipment	6-2
6.1. Common Tools and Equipment	6-2
6.2. Special Tools, TMDE, and Support Equipment	6-2
6.3. Repair Parts.....	6-2
Section II General Support Maintenance Procedures	6-3
6.4. Push Rods	6-3
6.5. Cylinder Head.....	6-5
6.6. Tappets.....	6-11
6.7. Valves.....	6-12
6.8. Valve Guide	6-17
6.9. Valve Spring	6-19
6.10. Valve Seat	6-21
6.11. Speed Control Plate	6-24
6.12. Gear Case	6-26
6.13. Idle Gear.....	6-30
6.14. Idle Gear Bushing.....	6-33
6.15. Idle Gear Shaft	6-35
6.16. Camshaft	6-36
6.17. Camshaft Gear	6-41
6.18. Fuel Camshaft	6-43
6.19. Injection Pump Gear	6-45
6.20. Crankshaft Gear	6-47
6.21. Oil Pump Gear.....	6-49
6.22. Pistons.....	6-50
6.23. Connecting Rod.....	6-54
6.24. Piston Rings	6-59
6.25. Bearing Case Cover	6-64
6.26. Crankshaft	6-66
6.27. Connecting Rod Bearing.....	6-69
6.28. Crankshaft Bearing 1	6-71
6.29. Crankshaft Bearings 2 and 3	6-74
6.30. Cylinder	6-76
6.31. Oil Pump Assembly	6-78
6.32. Radiator Seal Faring.....	6-80
6.33. Water Flange	6-82
6.34. Exciter Stator	6-84
6.35. Main Rectifier Assembly	6-88
6.36. Generator Bearing	6-90
6.37. Rotor.....	6-91

NOTE

Refer to "Table 1-1. Differences Between Models" for differences between MEP-903A, MEP-903B and MEP-903C, which may not be depicted in the TM illustrations.

Section I. REPAIR PARTS; SPECIAL TOOLS, TEST, MEASUREMENT, AND DIAGNOSTIC EQUIPMENT (TMDE); AND SUPPORT EQUIPMENT

6.1. COMMON TOOLS AND EQUIPMENT.

For authorized common tools and equipment, refer to the Modified Table of Organization and Equipment (MTOE), CTA 50-970, or CTA 81-010 as applicable to your unit.

6.2. SPECIALS TOOLS, TMDE, AND SUPPORT EQUIPMENT.

For all listing of special tools, TMDE, and support equipment authorized for use on this equipment, refer to Appendix C, Repair Parts and Special Tools List (RPSTL), and Appendix B, Maintenance Allocation Chart, of this manual.

6.3. REPAIR PARTS.

Repair parts are listed and illustrated in Appendix C, Repair Parts and Special Tools List, of this manual.

Section II. GENERAL SUPPORT MAINTENANCE PROCEDURES

6.4. PUSH RODS.

This task covers: Replace

INITIAL SETUP

Tools

None

Equipment Conditions

Rocker arm removed (para 5.36.).

Materials/Parts

Push Rods

REPLACE

- a. Remove push rods (1, Figure 6-1) from tappets by hand.

CAUTION

When replacing push rods, ensure that their ends are properly engaged with the grooves on the tappets.

- b. Install push rods (1) by hand.

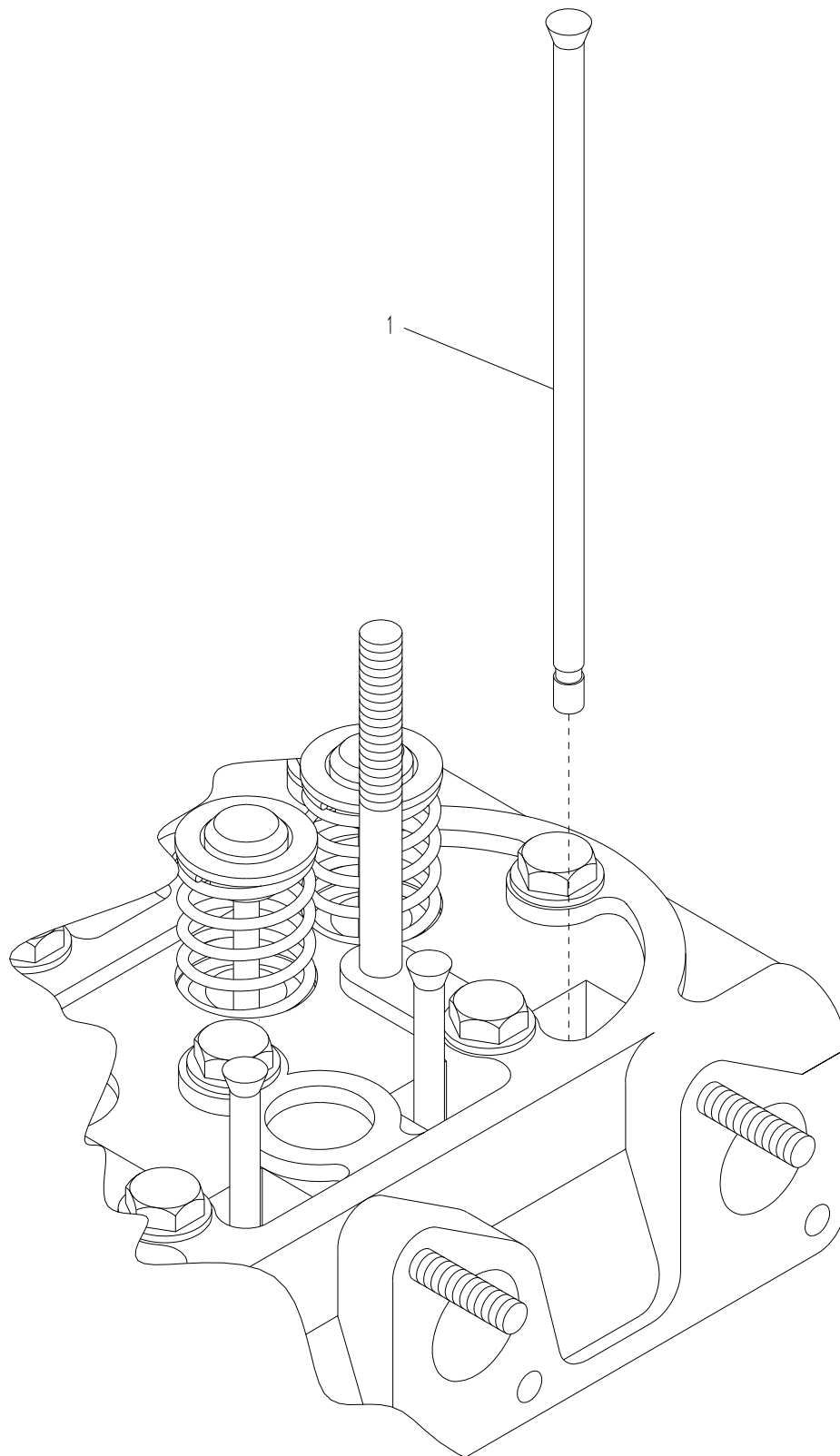

Figure 6-1. Push Rods

6.5. CYLINDER HEAD.

This procedure covers: a. Test b. Repair c. Replace

INITIAL SETUP

Tools

General Mechanic's Tool Kit
(Item 1, Appendix B)

Torque Wrench
(Item 2, Appendix B)

Depth Gauge
(Item 44, Appendix B)

Shop Equipment, Semitrailer Mounted,
Electrical Repair
(Item 3, Appendix B)

Surface Grinder
(Item 37, Appendix B)

Gloves, Chemical and Oil Protective
(Item 19, Appendix B)

Materials/Parts

Lubrication Oil
(Items 10-13, Appendix F)

Cylinder Head

Cylinder Head Gasket
(Item 2, Appendix J)

Inspection Penetrant Kit
(Item 8, Appendix F)

Equipment Conditions

Water flange removed (para 6.33.).

Injection nozzle assembly removed (para 5.13.).

Exhaust manifold removed (para 5.34.).

Intake manifold removed (para 5.35.).

Push rods removed (para 6.4.).

WARNING

Compressed air shall not be used for cleaning purposes except where reduced to less than 29 pounds per square inch gauge (psig) (199.94 kPa) and then only with effective chip guarding and personnel protective equipment. Compressed air is dangerous and can cause serious bodily harm if protective means or methods are not observed to prevent chip or particle (of whatever size) from being blown into the eyes or unprotected skin of the operator or other personnel.

TEST

- a. Remove cylinder head from engine block (perform steps a - d of REPLACE).
- b. Test cylinder head flatness. Proceed as follows:
 - (1) Clean cylinder head thoroughly.
 - (2) Place a straight edge along one side of cylinder head.
 - (3) Use a feeler gauge to measure clearance between cylinder head and straight edge. Allowable limit is 0.0020 in. (0.05 mm).

- (4) Refer to Figure 6-2 (Sheet 1) and repeat step 3, placing the straightedge along remaining three sides and diagonally across the face of the cylinder head.
- (5) If the clearance exceeds the allowable limit, repair cylinder.

NOTE

After refinishing the cylinder head, always check valve recessing.

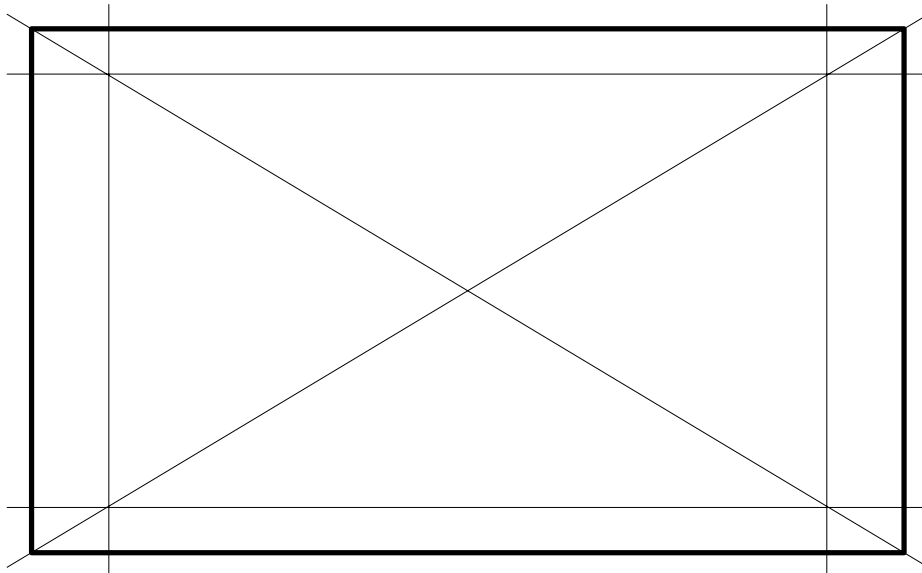

Figure 6-2. Cylinder Head (Sheet 1 of 4)

c. Inspect cylinder head for flaws.

- (1) Clean cylinder head ensuring that all dirt, grease, and water are removed.
- (2) Apply penetrant to cylinder head making sure to cover the entire surface of cylinder head.
- (3) Wait about ten minutes before proceeding to allow penetrant sufficient time to penetrate any flaws that may exist.
- (4) Remove penetrant with penetrant remover.
- (5) Apply a thin, uniform layer of developer. If flaws exist, they will become apparent when developer is applied.
- (6) If flaws exist on cylinder head, replace cylinder head.

d. Test valve recessing.

- (1) Clean cylinder head, valve face, and valve seat.
- (2) Insert valve into the valve guide.
- (3) Use depth gauge (1, sheet 2) to measure valve recessing. The valve recessing should be between -0.0039 in. (-0.10 mm) and -0.0039 in. (-0.10 mm).
- (4) If valve recessing exceeds tolerance, replace valve (para 6.7.).
- (5) Test valve recessing again. If recessing still exceeds allowable limit, adjust the valve seat (para 6.10.).
- (6) Test valve recessing a final time. If recessing continues to exceed allowable limit, repair cylinder head.

REPAIR

Refinish cylinder head within tolerance (step b, TEST).

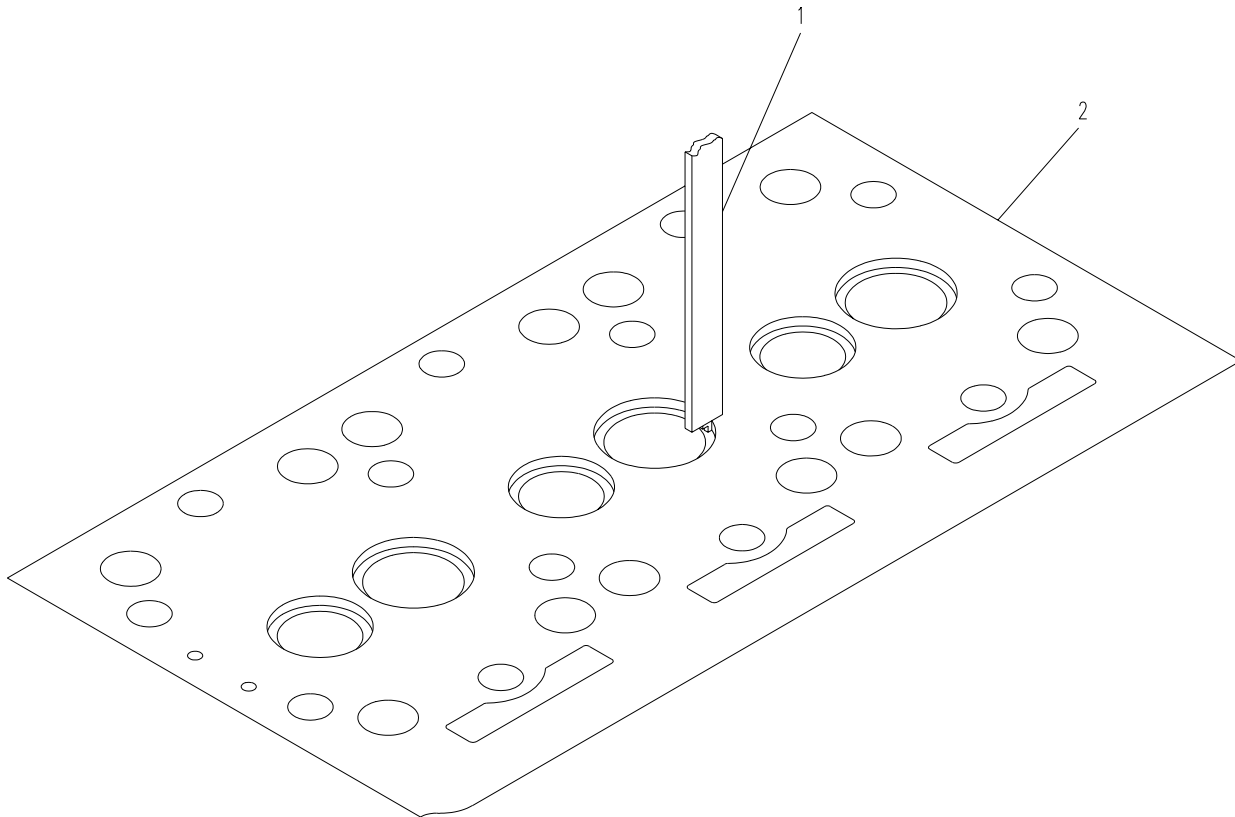

Figure 6-2. Cylinder Head (Sheet 2)

CAUTION

Refer to Figure 6-2 (Sheet 3) and observe sequence of cylinder head bolts removal to ensure proper installation.

REPLACE

- a. Refer to Figure 6-2 (sheets 3 and 4) and remove 14 bolts (2, sheet 4) securing cylinder head (1) to engine block in the following order (sheet 3): 10, 14, 13 through 11, 9 through 1. Retain hardware.
- b. Remove cylinder head (1, sheet 2) from engine block.
- c. Remove head gasket (3, sheet 4) from cylinder head (1). Ensure there is no debris on engine block. Clean cylinder head thoroughly if required.

- d. Remove water flange (para 6.33.).

CAUTION

When installing, take care not to damage the head gasket and cylinder head gasket (3).

- e. Install water flange and gasket on new cylinder head (para 6.33.).
- f. Install new cylinder head (1) and cylinder head gasket (3), Figure 6-2, sheet 4.
- g. Apply lubricating oil to screws (2) used to secure cylinder head.
- h. Refer to sheet 3 and secure cylinder head to engine block in the following order: Torque cylinder head bolts in increments of 10ft-lbs, 1 through 9, 11 through 13, 14, 10. Torque between 28.9 and 32.5 ft-lbs (4.0 to 4.5 kg-fm).
- i. Run engine for 30 minutes and tighten screws to torque values in step h.

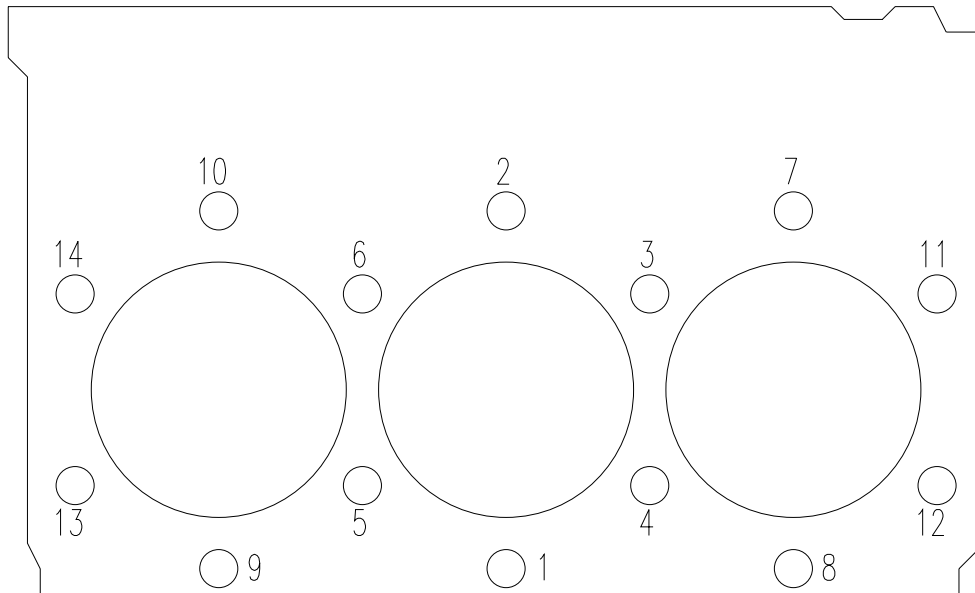

Figure 6-2. Cylinder Head (Sheet 3)

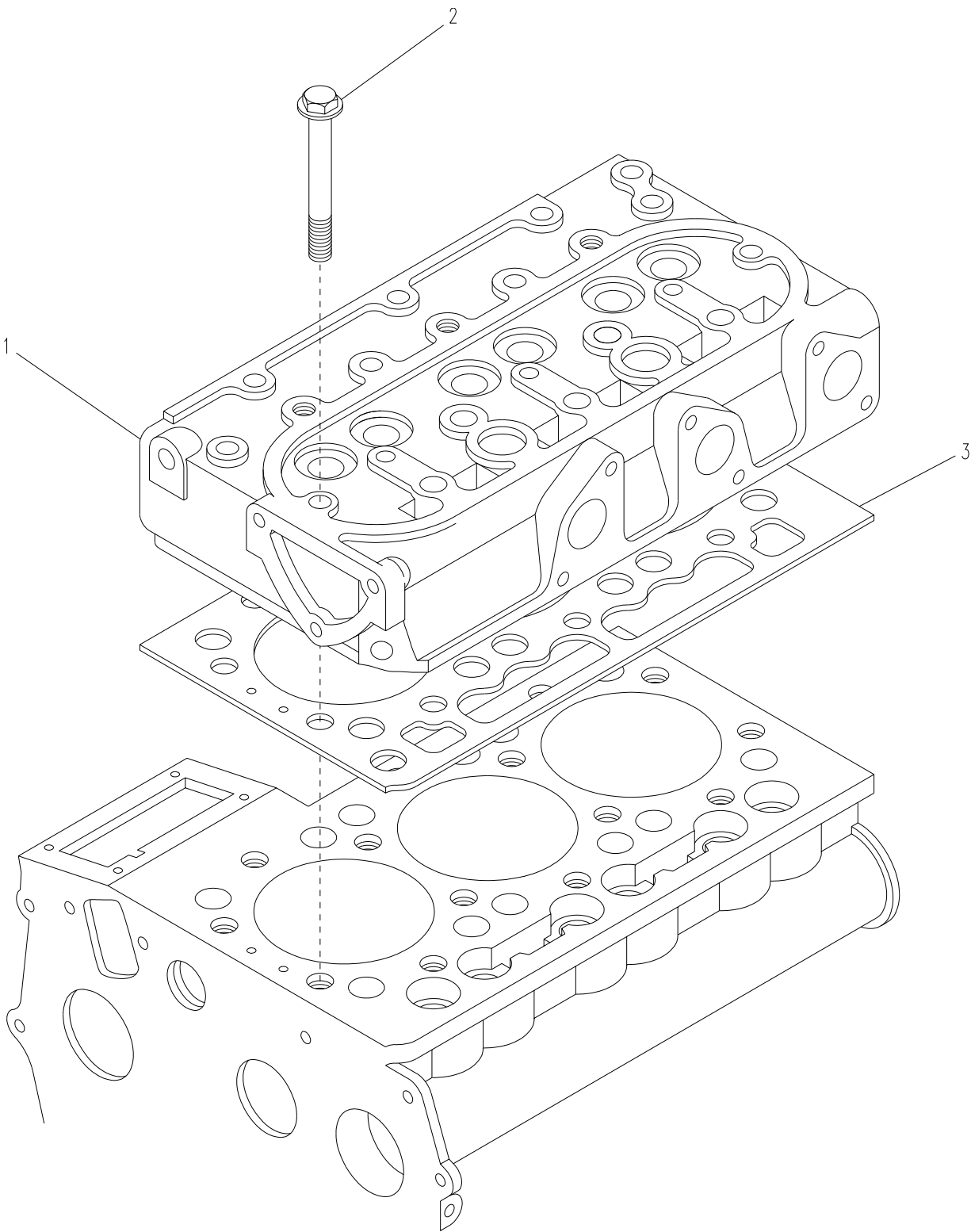

Figure 6-2. Cylinder Head (Sheet 4)

6.6. TAPPETS.

This task covers: Replace

INITIAL SETUP

Tools

None

Equipment Conditions

Cylinder head removed (para 6.5.).

Materials/Parts

Tappets

Lubricating Oil
(Items 10-13, Appendix F)

REPLACE

CAUTION

Mark each cylinder (1) and tappet (2) to prevent interchanging tappets upon replacement.

- a. Remove tappets (2, Figure 6-3) from crankcase by hand and discard.
- b. Apply a thin layer of oil to each new tappet (2).
- c. Replace tappets (2) by hand in the same order they were removed.

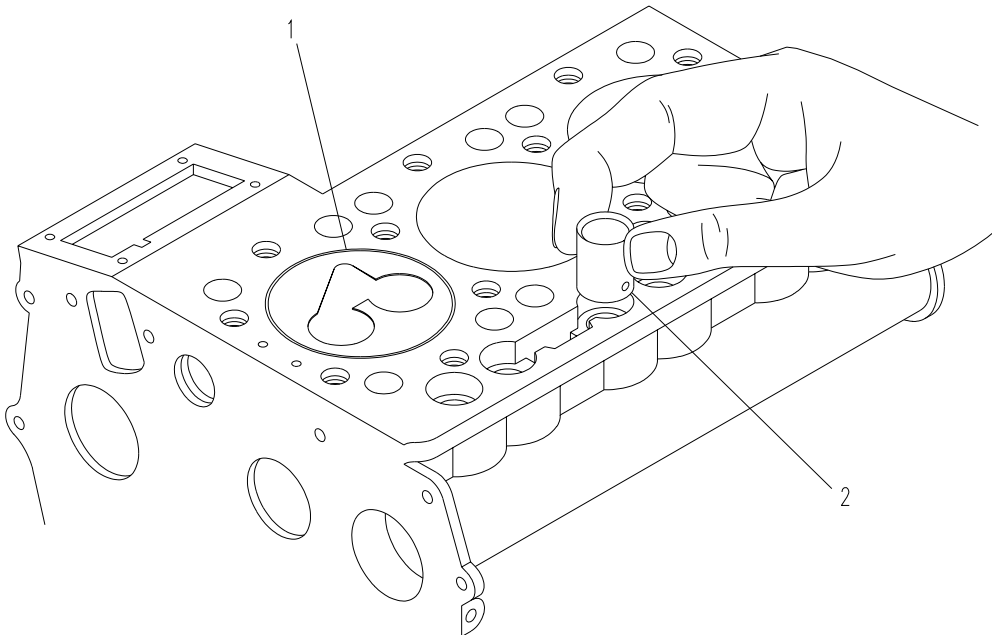

Figure 6-3. Tappets

6.7. VALVES.

This task covers: a. Test b. Adjust c. Replace

INITIAL SETUP

Tools

Shop Equipment, Electrical, Repair,
Semitrailer Mounted
(Item 3, Appendix B)

Valve Spring Lifter
(Item 38, Appendix B)

Outside Micrometer Caliper
(Item 43, Appendix B)

Small Hole Gauge
(Item 5, Appendix B)

Gloves, Chemical and Oil Protective
(Item 34, Appendix B)

Materials/Parts

Lubricating Oil
(Items 10-13, Appendix F)

Valve

Lapping Compound
(Item 24, Appendix F)

Red Lead
(Item 14, Appendix F)

TEST

- a. Remove and disassemble valve (perform steps a - e of REPLACE).
- b. Remove carbon from valve guide.
- c. Measure valve stem OD with an outside micrometer caliper. Refer to Figure 6-4, Sheet 1) for measurement locations. The OD should be between 0.23496 and 0.23543 in. (5.968 and 5.980 mm).
- d. Measure valve guide ID with a small hole gauge. ID should be between 0.23661 and 0.23720 in. (6.010 and 6.025 mm).
- e. Calculate oil clearance (refer to Figure 6-4). Clearance should be between 0.00118 and 0.00224 in. (0.030 and 0.057 mm) with an allowable limit of ± 0.0039 in. (0.10 mm). If clearance exceeds allowable limit, replace valve and valve guide (para 6.8.) (Figure 6-4) (Sheet 1).

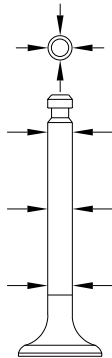

0.23496 to 0.23543 in.
(5.968 to 5.980 mm)

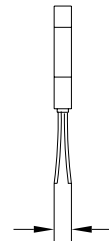
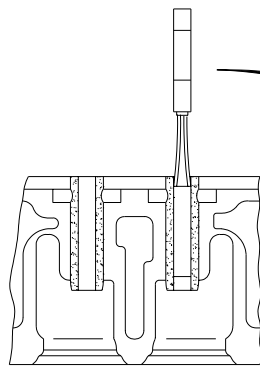

0.23661 to 0.23720 in.
(6.010 to 6.025 mm)

Figure 6-4. Valves (Sheet 1 of 3)

ADJUST

- a. Remove valve (perform step a through e of REPLACE).
- b. Apply lapping compound evenly to valve face.
- c. Insert valve (1, Figure 6-4 (sheet 3)) into valve guide.
- d. Use a screwdriver to lap the valve (1) onto its seat.
- e. After lapping the valve, wash the compound away, apply lubricating oil and repeat steps c and d.

WARNING

Wear protective gloves when using red lead. Dispose of red lead in accordance with local ordinances.

- f. Apply red lead to contact surface of valve and visually check and note the seated rate.

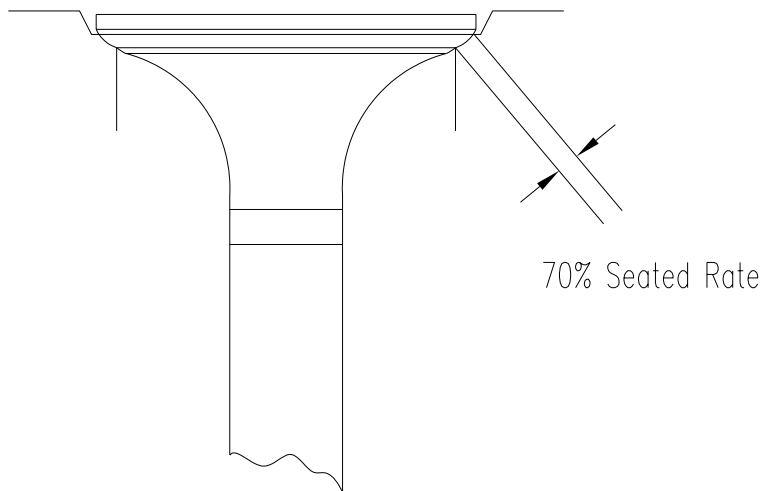

Figure 6-4. Valves (Sheet 2)

- g. Clean off red lead with approved solvent with a clean rag.
- h. If sealed rate is under 70%, repeat steps a - d.

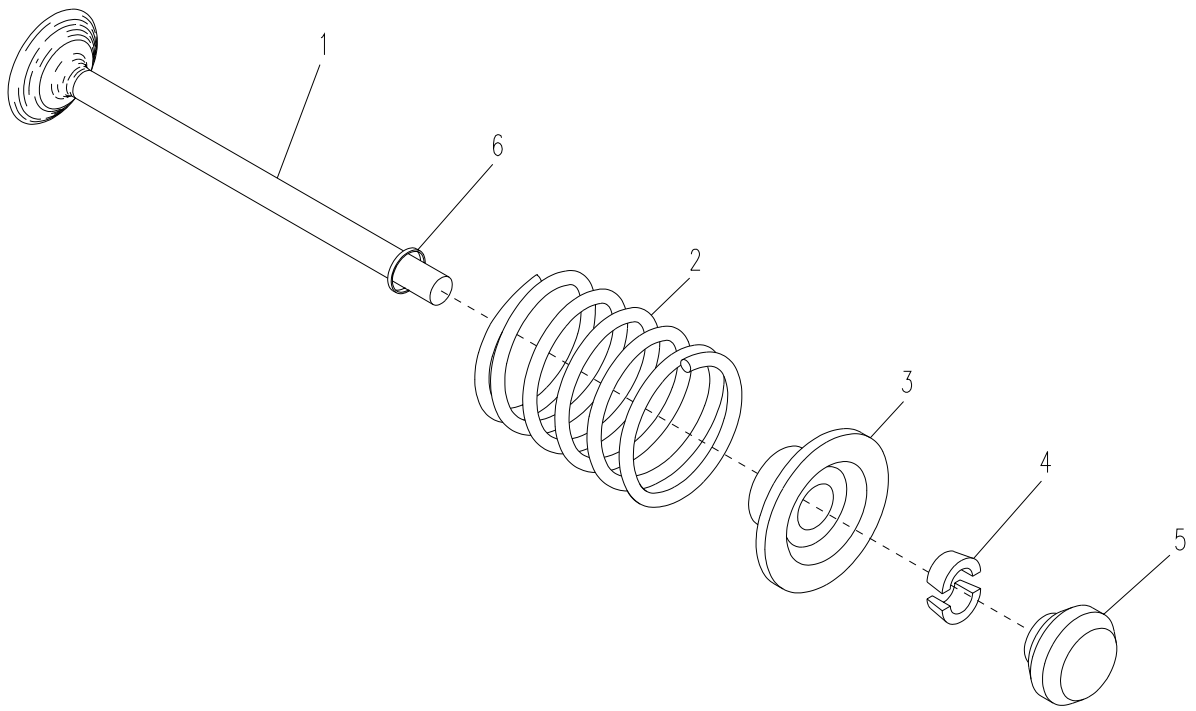

Figure 6-4. Valves (Sheet 3)

REPLACE

CAUTION

Make a note of which valve comes out from each valve guide. Valves must be replaced in the same location they were removed from.

- a. Remove valve cap (5) by hand.
- b. Use valve lifter to remove valve spring collet (4) from valve (1).
- c. Remove valve spring retainer (3) from valve (1).
- d. Remove valve spring (2) from valve (1) by hand.
- e. Remove valve stem seal (6) from valve (1) by hand.
- f. Remove valve (1) from cylinder head by hand (Figure 6-4, sheet 3).

NOTE

Before reassembling valve, clean and apply engine oil to the valve stem and valve guide hole.

- g. Lap the new valves (perform steps b - f of ADJUST).
- h. Install new valve stem seal (6).
- i. Install valve spring (2) on valve (1).
- j. Install valve spring retainers (3) on valve (1).
- k. Use valve lifter to install valve spring collet (4) on valve (1).
- l. Install valve cap (5) on valve (1).
- m. Use a plastic hammer to lightly tap on the valve stem to ensure a proper fit.

6.8. VALVE GUIDE.

This task covers: Replace

INITIAL SETUP

Tools

Valve Guide Replacing Tool
(Item 15, Appendix B)

Reamer (special tool)
(Item 32, Appendix B)

Materials/Parts

Lubricating Oil
Valve Guide

Equipment Conditions

Cylinder head removed (para 6.5.).

Valves removed (para 6.7.).

REPLACE

- a. Press valve guide (3, Figure 6-5) out of cylinder head (2) with a valve guide replacing tool (1).
- b. Clean and apply lubricating oil to new valve guide.

CAUTION

Do not use a hammer or similar instrument to strike the valve guide during replacement.

- c. Using a valve guide replacing tool (1), press valve guide (3) into cylinder head (2) until flush with the cylinder head (2).
- d. Use reamer to ream the ID of valve guide between 0.23661 and 0.23721 in. (6.010 and 6.025 mm).

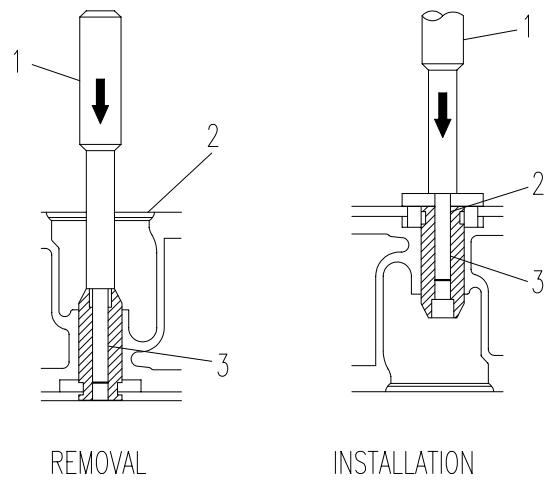

Figure 6-5. Valve Guide

6.9. VALVE SPRING.

This task covers: Test

INITIAL SETUP

Tools

Shop Equipment, Electrical Repair,
Semitrailer Mounted
(Item 3, Appendix B)

Outside Micrometer Caliper
(Item 43, Appendix B)

Materials/Parts

Valve Spring

Equipment Conditions

Valve spring removed from valve (para 6.9.).

TEST

- a. Test free length and tilt.
 - (1) Refer to Figure 6-6 and use outside micrometer caliper to measure length of valve spring. If length is less than 1.118 in. (28.4 mm), replace valve spring.
 - (2) Place valve spring on a surface plate and place a square (1) on the side of valve spring (2).
 - (3) Rotate valve spring to ensure that entire valve spring is flush with the square (1).
 - (4) If valve spring is not flush with the square, refer to Figure 6-6 and measure the distance from edge of spring and square (1). If length exceeds 0.047 in. (1.2 mm), replace valve spring.
 - (5) Check the entire surface of valve spring for scratches. If any scratches exist, replace valve spring.
- b. Test valve spring setting load.
 - (1) Place valve spring on setting tester.
 - (2) Compress valve spring to 1.063 in. (27 mm).
 - (3) Observe the compression load on the setting tester gauge. If it is less than 12.3 lbs (54.9 N), replace the valve spring.

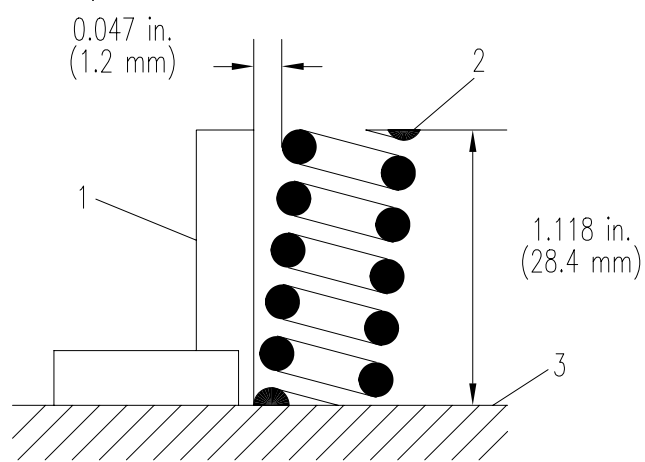

Figure 6-6. Valve Spring

6.10. VALVE SEAT.

This task covers: a. Test b. Adjust

INITIAL SETUP

Tools

General Mechanic's Tool Kit
(Item 1, Appendix B)

Valve Seat Cutter
(Item 8, Appendix B)

Grinding Machine, Valve Face
(Item 35, Appendix B)

Gloves, Chemical and Oil Protective
(Item 34, Appendix B)

Red Lead
(Item 14, Appendix F)

Materials/Parts

Valves

Equipment Conditions

Valves removed (para 6.7.).

Engine shut down and allowed to cool completely.

TEST

- a. Remove valve (perform step a thru f of REPLACE, para 6.7.).
- b. Refer to Figure 6-7 (Sheet 1) and measure width of contact between valve face and valve seat. Contact should be 0.0835 in. (2.12 mm).
- c. If width of contact is excessive or uneven, adjust seat.

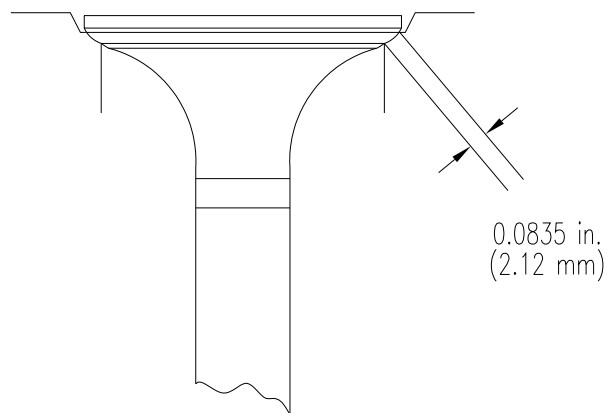

Figure 6-7. Valve Seat (Sheet 1 of 2)

ADJUST

NOTE

Before adjusting the valve and seat, check clearance between valve stem and the valve guide (para 6.7., steps c. and d.).

NOTE

After adjusting valve seat, check cylinder head for valve recessing (para 6.5., TEST, step d).

- a. Use a valve grinder to grind the face of the valve to a 45° to 45.5° angle.
- b. Correct valve seat. Proceed as follows:
 - (1) Use a 45° valve seat cutter to grind the valve seat surface (1, Figure 6-7).
 - (2) Apply red lead to valve.

WARNING

Wear protective gloves when using red lead and dispose of red lead in accordance with local ordinance.

- (3) Fit valve in valve seat and visually check the contact position of valve face and valve seat (2).

NOTE

If the valve has been used for a long period, the seat will tend to come in contact with the upper side of the valve face.

- (4) Grind the upper surface of valve seat with a 15° valve seat cutter until the contact area between valve seat and valve face is centered on the valve face.
- (5) Use a 45° valve seat cutter and regrind valve seat.
- (6) Check the contact between the valve and valve seat.
- (7) If contact between the valve and valve seat is not correct, repeat steps b(3) - b(6) until the correct contact is achieved.
- (8) Once correct contact is achieved, lap the valve (para 6.7., ADJUST) until the seated rate becomes more than 70% of the total contact area.

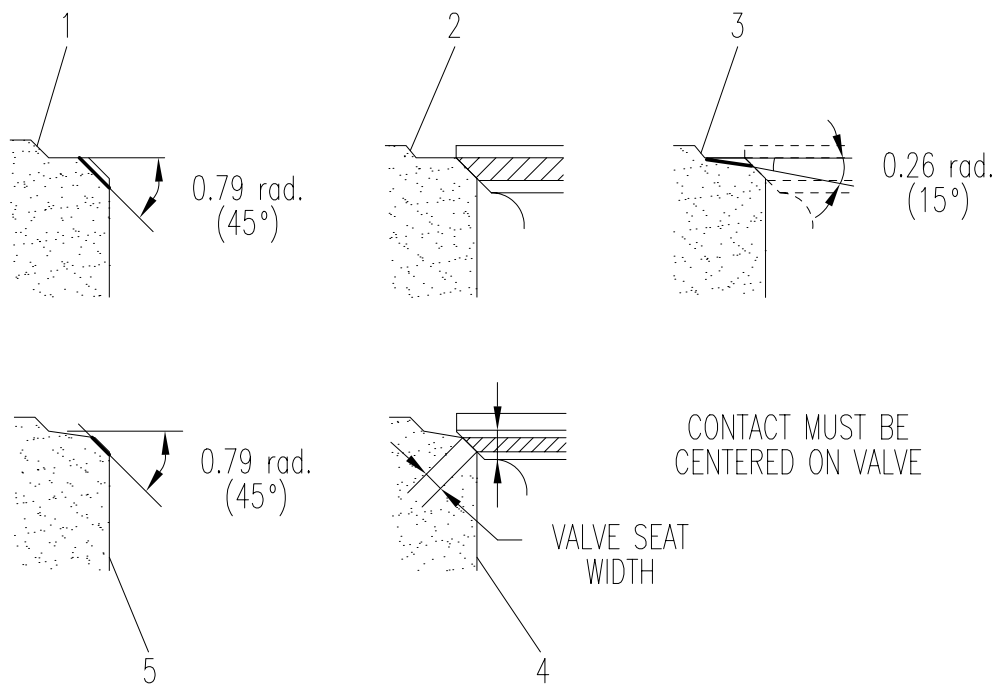

Figure 6-7. Valve Seat (Sheet 2)

6.11. SPEED CONTROL PLATE.

This task covers: Replace

INITIAL SETUP

Tools

General Mechanic's Tool Kit
(Item 1, Appendix B)

Equipment Conditions

Engine off and allowed to cool for 30 minutes.

Materials/Parts

Speed Control Plate

MASTER ON-OFF switch on APU controller set to OFF.

Sealing Compound
(Item 18, Appendix F)

Actuator linkage removed (para 4.50.).

REPLACE

- a. Remove four bolts and washers (1, Figure 6-8) securing speed control plate (2) to engine.

CAUTION

When separating speed control plate from engine body,
take care not to damage the speed control plate spring.

- b. Carefully separate speed control plate (2) from engine, but DO NOT REMOVE.
- c. Disconnect speed control plate spring (4) from lever (3) on under side of speed control plate (2).
- d. Remove speed control plate (2) and clean parts to be reinstalled.
- e. Apply sealing compound to new speed control plate (2).
- f. Connect loose end of speed control plate spring (4) to lever (3) on under side of speed control plate (2).
- g. Install speed control plate (2) and secure with four washers and bolts (1).

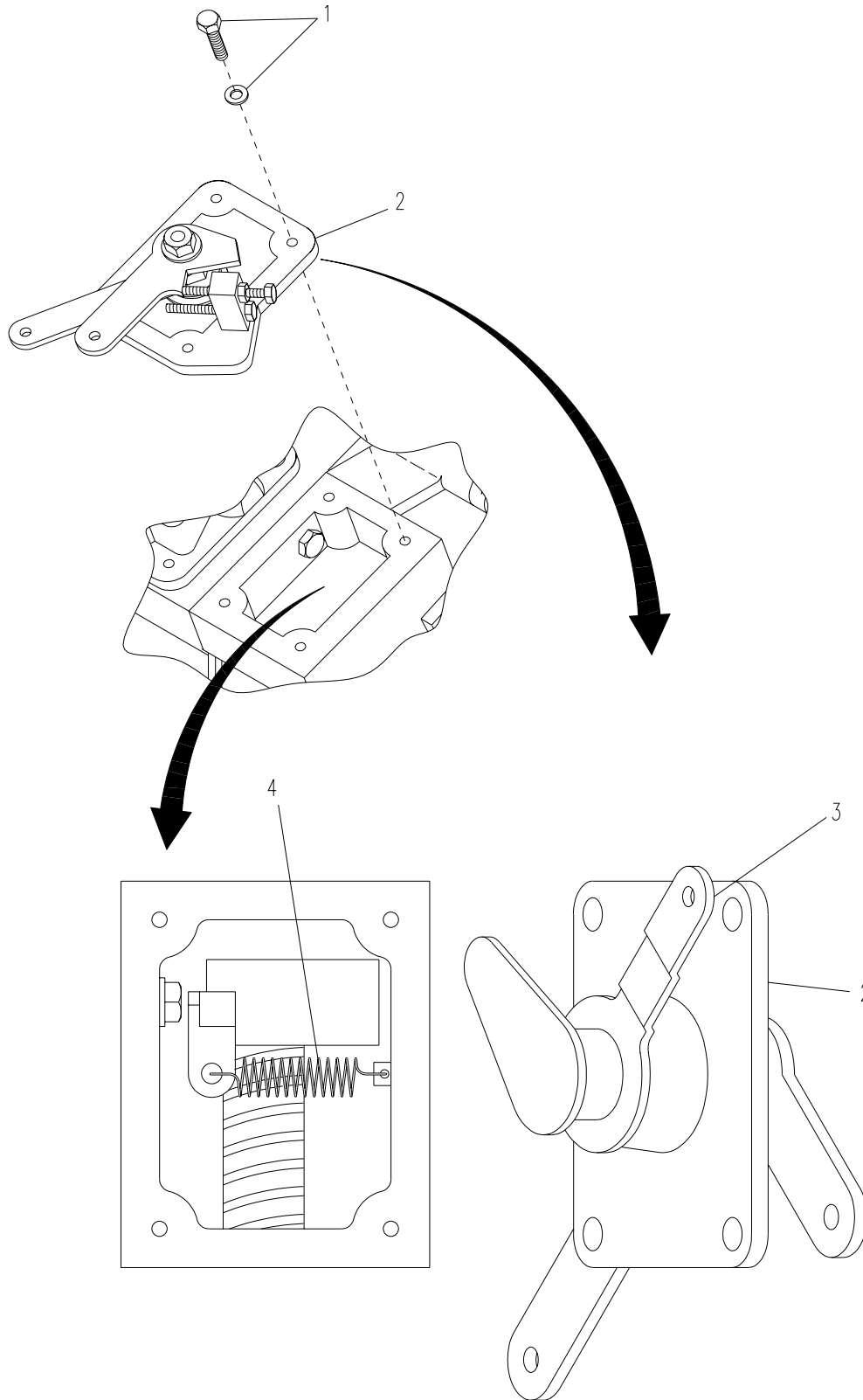

Figure 6-8. Speed Control Plate

6.12. GEAR CASE.

This task covers: Replace

INITIAL SETUP

Tools

General Mechanic's Tool Kit
(Item 1, Appendix B)

Materials/Parts

Gear puller, if needed (spec tool)

Gear Case

Gear Case Gasket

Sealing Compound
(Item 18, Appendix F)

Oil Seal
(Item 15, Appendix J)

Gear Case O-rings
(Item 13, Appendix J)

Equipment Conditions

Oil cooler removed (para 4.16.).
Water pump removed (para 5.12.).
Fuel feeder pump removed (para 4.34.).
Radiator removed (para 4.19.).
Injection pump removed (para 5.14.).
Speed control plate removed (para 6.11.).

REPLACE

- a. Remove one bolt (3, Figure 6-9) securing crankshaft pulley (4) to crankshaft and remove pulley (4).
- b. Inside speed control plate mounting hole, disconnect start spring (6).
- c. Inside speed control plate mounting hole, remove one bolt (1) securing gear case (2) to engine.
- d. Remove three nuts and lock washers (11) and remove oil filler (12).
- e. Remove three oil filler studs (10).
- f. Remove fifteen bolts (13) securing gear case (2) to engine and remove gear case (2).
- g. Remove three O-rings (8) from gear case (2).
- h. Remove gasket (7) from gear case (2).
- i. Remove oil ring (9) from gear case (2).
- j. Apply sealing compound to both sides of new gasket (7) and install gasket (7) on gear case (2).
- k. Install three O-rings (8) to gear case (2).
- l. Install oil ring (9) in gear case (2).

- m. Install gear case (2) to engine and secure with fifteen bolts (13). Torque between 7.23 and 8.32 ft-lbs (9.81 and 11.3 Nm).
- n. Inside speed control plate mounting hole, reconnect start spring (6).
- o. Inside speed control plate mounting hole, install one bolt (1).
- p. Install three oil filler studs (10).
- q. Install oil filler (12) on three studs and secure with three lock washers and nuts (11).
- r. Ensuring marks (5) on crankshaft pulley (4) and crankshaft are aligned, install crankshaft pulley (4) and secure with one bolt (3). Torque between 72.3 and 79.6 ft-lbs (98.1 to 11.3 Nm).

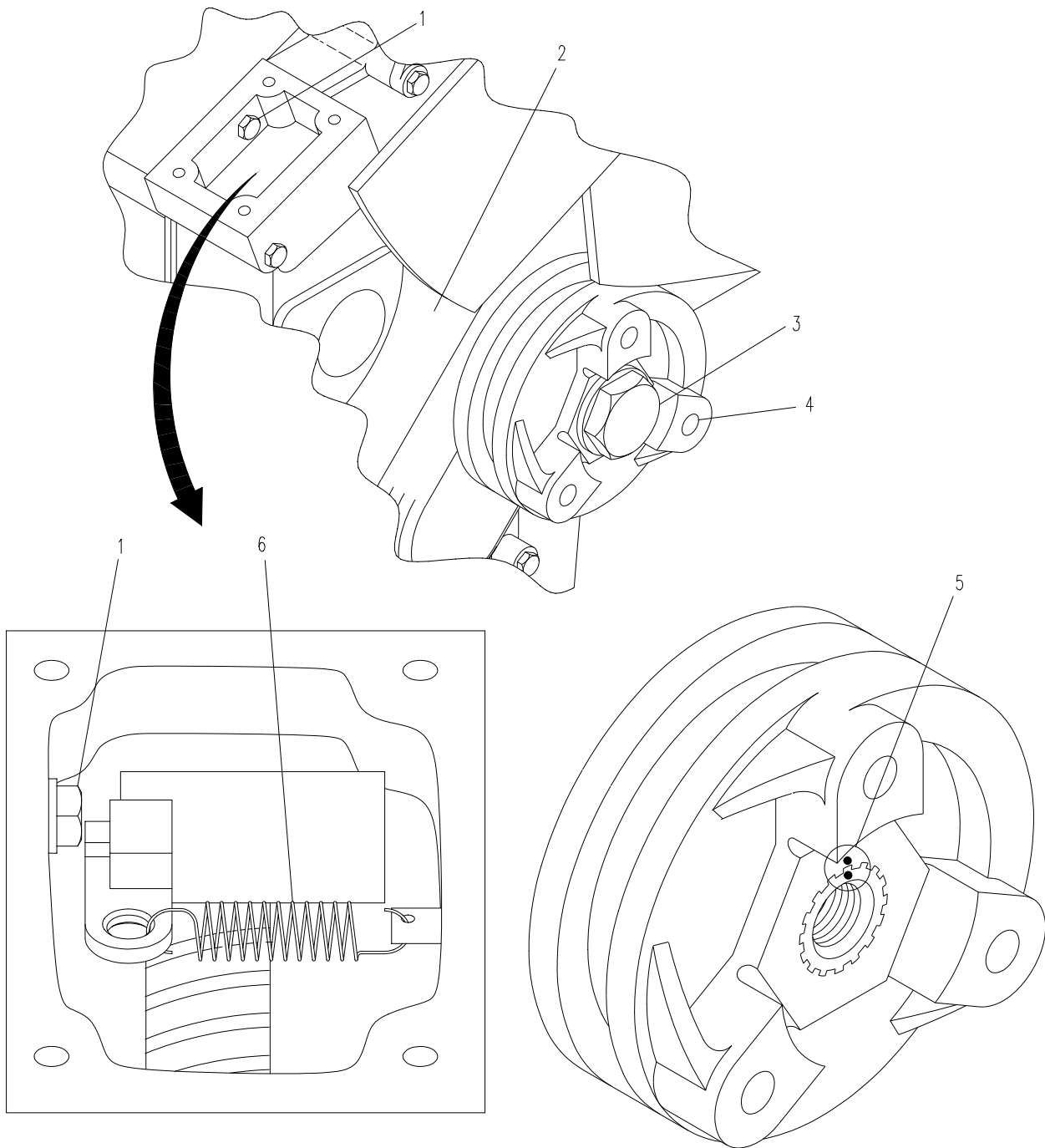

Figure 6-9. Gear Case (Sheet 1 of 2)

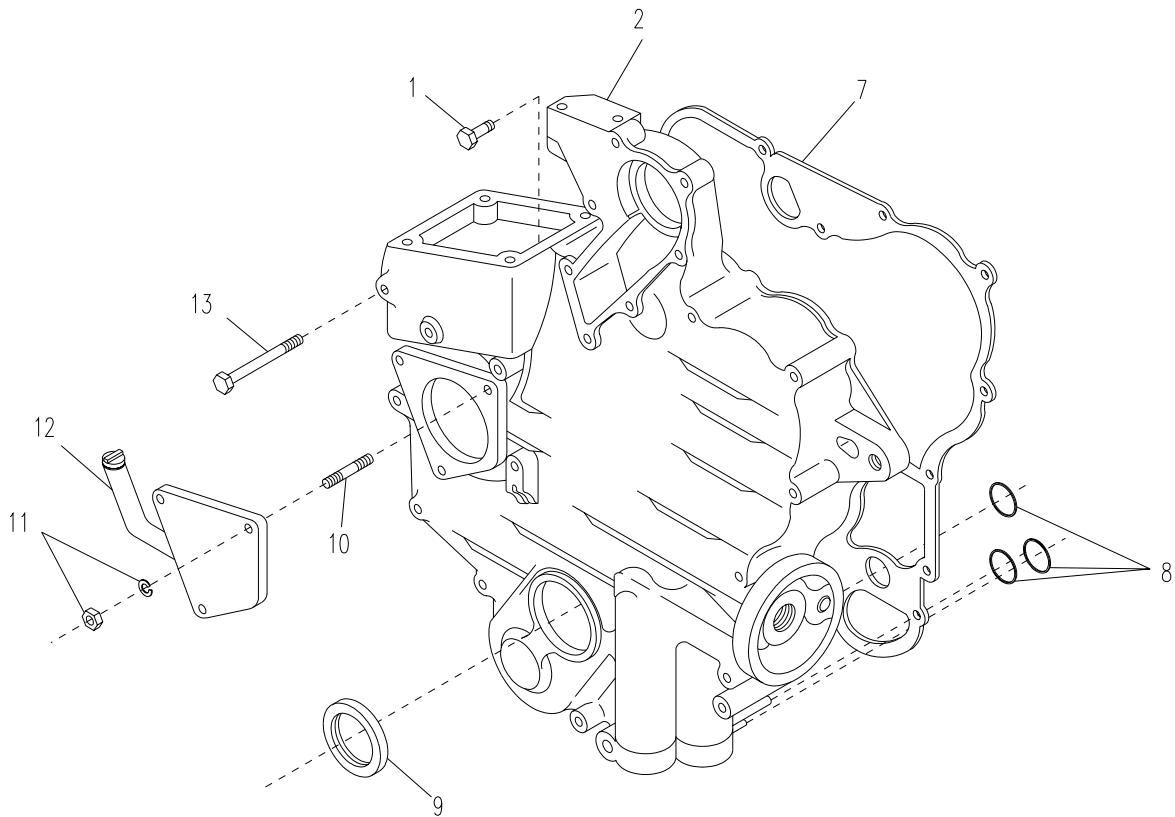

Figure 6-9. Gear Case (Sheet 2 of 2)

6.13. IDLE GEAR.

This task covers: a. Test b. Replace

INITIAL SETUP

Tools

General Mechanic's Tool Kit
(Item 1, Appendix B)

Shop Equipment

Special Use Puller Set
(Item 9, Appendix B)

Dial Indicator
(Item 36, Appendix B)

Materials/Parts

Idle Gear

Equipment Conditions

Gear case removed (para 6.12.).

TEST

NOTE

When performing this procedure, also check camshaft gear (para 6.17.), injection pump gear (para 6.19.), and crankshaft gear (para 6.20.).

- a. Set up a dial indicator with its tip on the idle gear (1, Figure 6-10).
- b. Measure side clearance by moving idle gear to the front and rear.
- c. If side clearance is beyond 0.0236 in. (0.60 mm), replace idle gear or idle gear shaft (para 6.21.).

REPLACE

- a. Remove external snap ring (3) and collar (2).
- b. Use special use puller set to remove gear (1).
- c. Install idle gear, ensuring that marks (4) on all gears are aligned (sheet 2).
- d. Secure idle gear with collar (2) and snap ring (3).

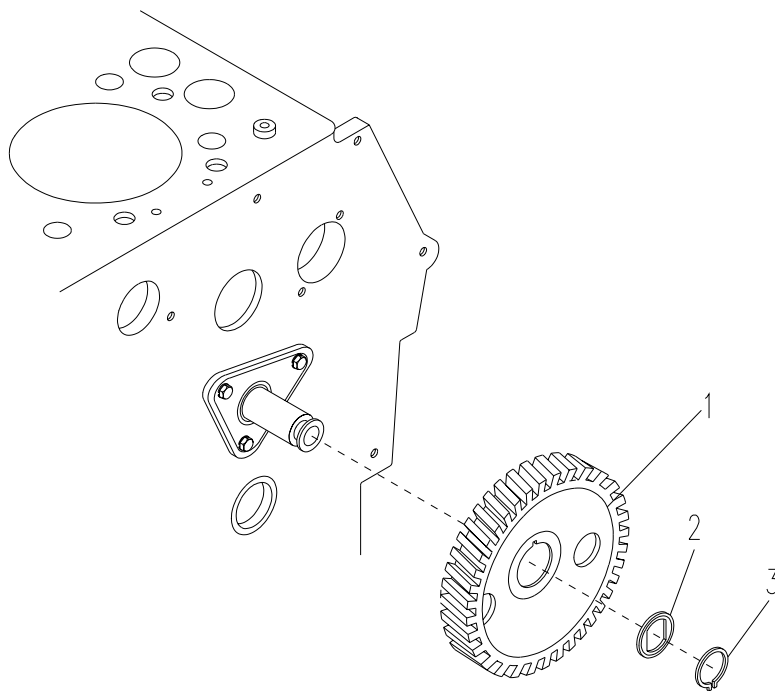
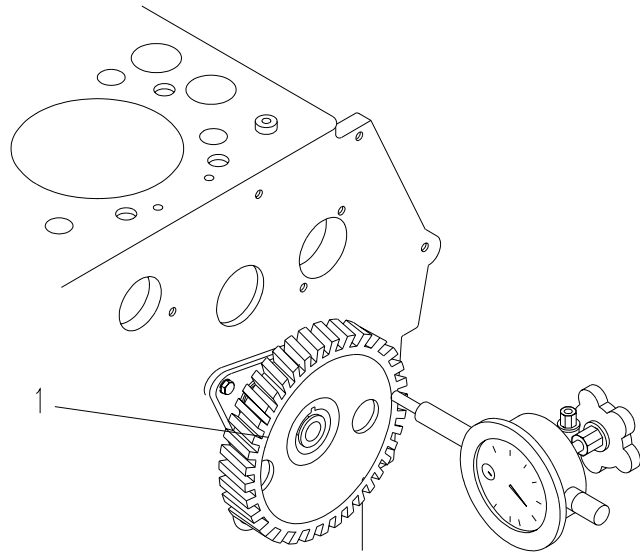

Figure 6-10. Idle Gear (Sheet 1 of 2)

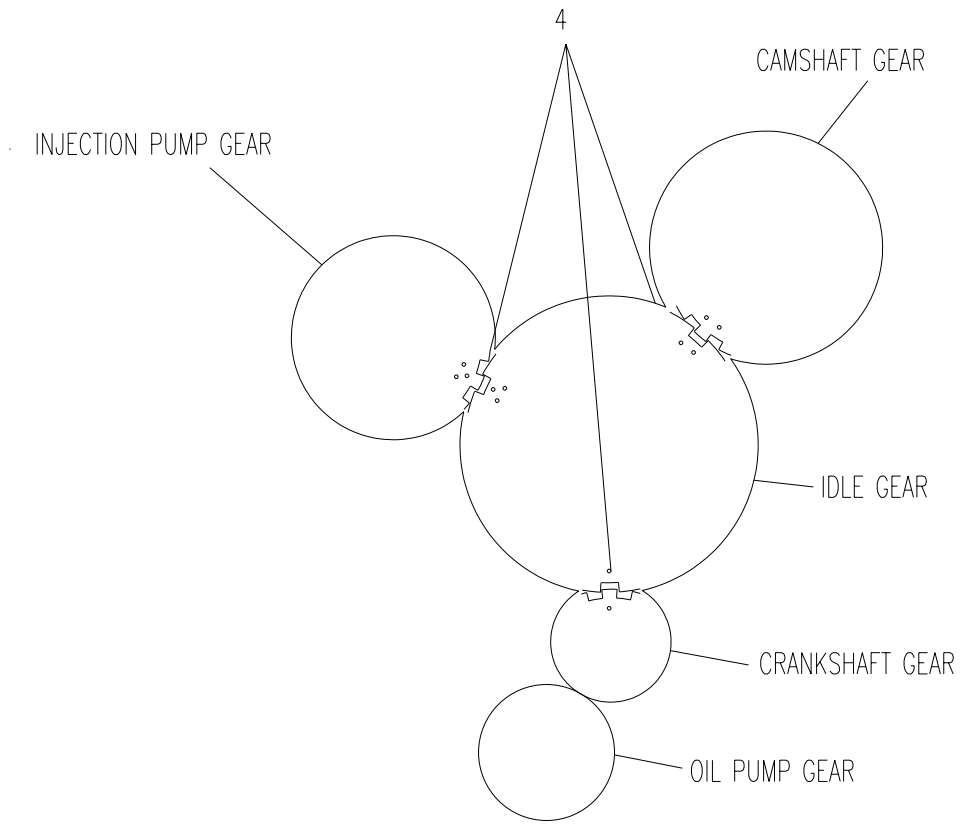

Figure 6-10. Idle Gear (Sheet 2)

6.14. IDLE GEAR BUSHING.

This task covers: a. Test b. Replace

INITIAL SETUP

Tools

General Mechanic's Tool Kit
(Item 1, Appendix B)

Inside Micrometer Caliper
(Item 42, Appendix B)

Outside Micrometer Caliper
(Item 43, Appendix B)

Idle Gear Bushing Replacing Tool
(Item 18, Appendix B)

Equipment Conditions

Gear case removed (para 6.12.).

Materials/Parts

Idle Gear

TEST

- a. Refer to Figure 6-11 and use inside micrometer caliper to measure the ID of idle gear bushing. It should measure between 0.78740 and 0.78941 in. (20 and 20.051 mm).
- b. Use outside micrometer caliper to measure the OD of idle gear shaft. It should measure between 0.78610 and 0.78661 in. (19.967 and 19.980 mm).
- c. Calculate oil clearance between idle gear bushing and idle gear. It should be between 0.00079 and 0.00331 in. (0.020 and 0.084 mm).
- d. If oil clearance exceeds allowable limit, replace bushing and retest oil clearance.
- e. If oil clearance still exceeds allowable limit, replace idle gear shaft (para 6.15.).

REPLACE

- a. Refer to Figure 6-11 and use idle gear bushing replacing tool to press idle gear bushing out from idle gear.
- b. Use idle gear bushing tool to install idle gear bushing in idle gear. Leave 0 to 0.0079 in. (0 to 0.2 mm) clearance between ends of idle gear bushing and idle gear.

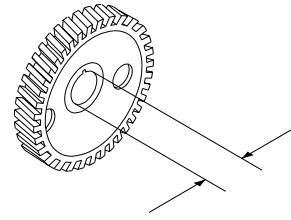
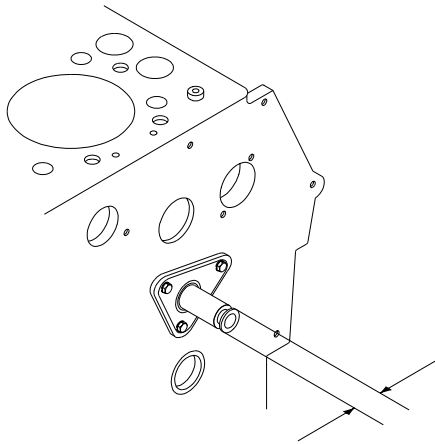

0.78610 to 0.78661 in.
(19.967 to 19.980 mm)

0.78740 to 0.78941 in.
(20.000 to 20.051 mm)

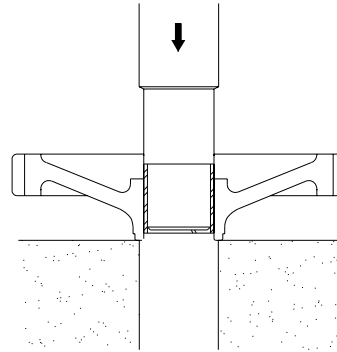
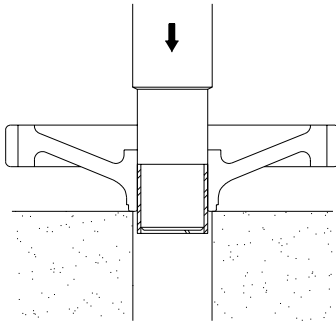

0 to 0.0079 in.
(0 to 0.2 mm)

0 to 0.0079 in.
(0 to 0.2 mm)

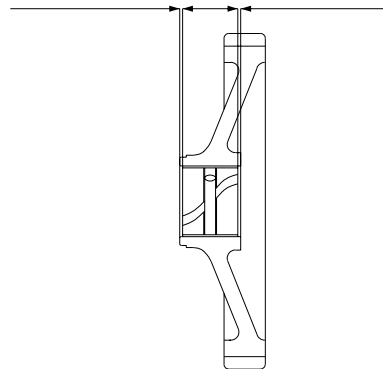

Figure 6-11. Idle Gear Bushings

6.15. IDLE GEAR SHAFT.

This task covers: Replace

INITIAL SETUP

Tools

General Mechanic's Tool Kit
(Item 1, Appendix B)

Equipment Conditions

Idle gear removed (para 6.13.).

Materials/Parts

Idle Gear Shaft

REPLACE

- a. Remove three bolts (2, Figure 6-12) and remove idle gear shaft (1).
- b. Install idle gear shaft (1) and secure with three bolts (2).

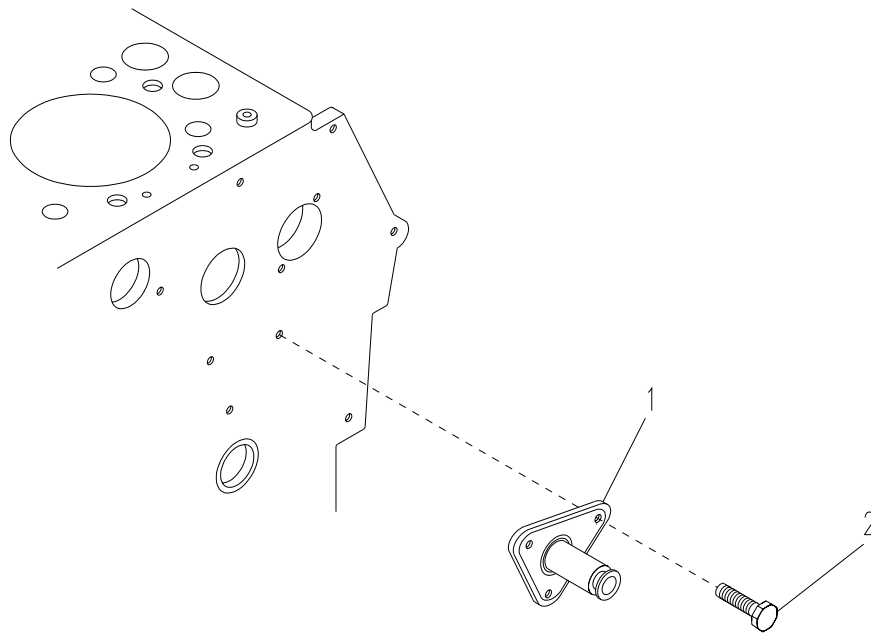

Figure 6-12. Idle Gear Shaft

6.16. CAMSHAFT.

This task covers: a. Test b. Replace

INITIAL SETUP

Tools

General Mechanic's Tool Kit
(Item 1, Appendix B)

Shop Equipment, Electrical Repair,
Semitrailer Mounted
(Item 3, Appendix B)

Inside Micrometer Caliper
(Item 47, Appendix B)

Outside Micrometer Caliper
(Item 48, Appendix B)

Dial Indicator
(Item 36, Appendix B)

Materials/Parts

Camshaft

TEST

- a. Remove camshaft (perform steps a - b of REPLACE).
- b. Test camshaft alignment:
 - (1) On a surface plate, set camshaft (2, Figure 6-13) on two V-blocks.
 - (2) Set up a dial (1) indicator at a right angle to the camshaft with its tip on camshaft's middle journal.
 - (3) Rotate camshaft on the V-blocks and check for misalignment.
 - (4) If the misalignment exceeds 0.0004 in. (0.01 mm), replace camshaft.

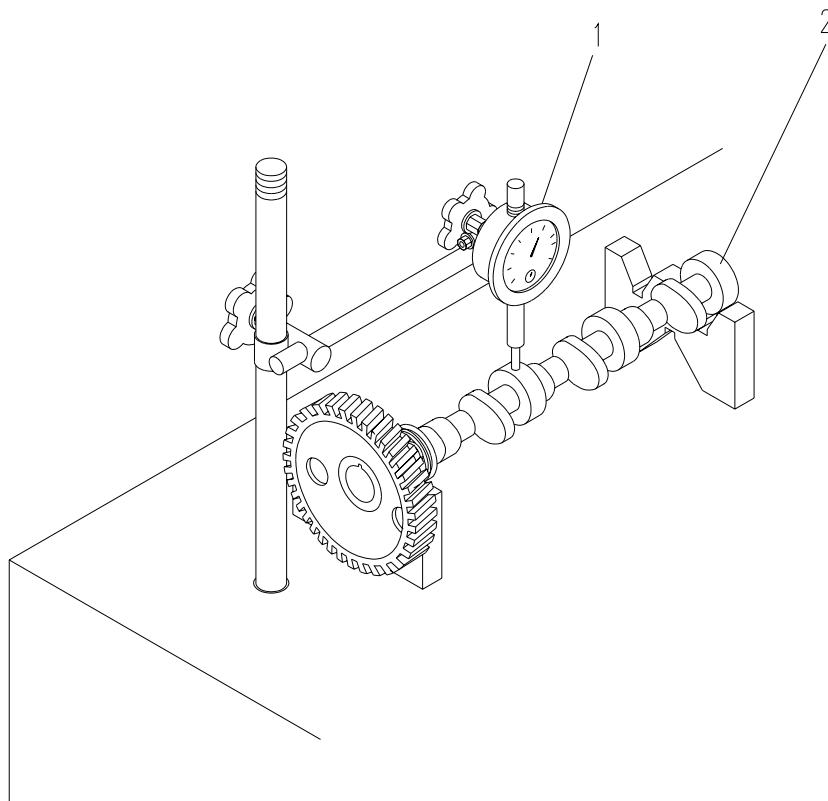

Figure 6-13. Camshaft (Sheet 1 of 4)

c. Test camshaft journal oil clearance:

- (1) Measure camshaft journal OD with outside micrometer caliper. It should be between 1.29662 and 1.29725 in. (32.934 and 32.950 mm).
- (2) Measure cylinder block bore ID for camshaft journal with inside micrometer caliper. It should be between 1.29921 and 1.30020 in. (33 and 33.025 mm).
- (3) Calculate oil clearance. It should be between 0.00197 and 0.00358 in. (0.050 and 0.091 mm). If oil clearance exceeds allowable limit, replace the camshaft.

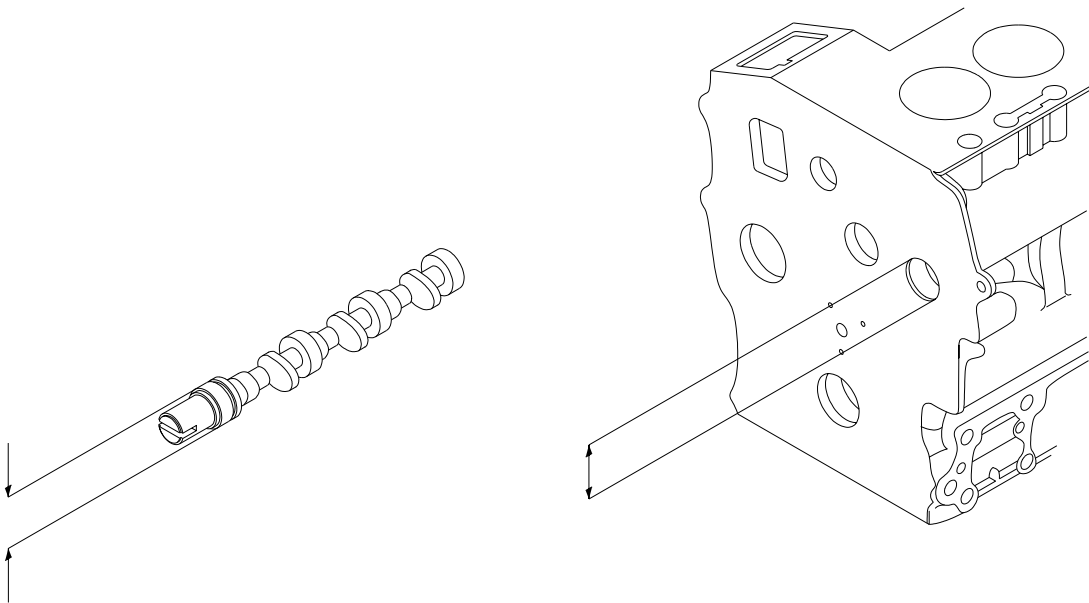

Figure 6-13. Camshaft (Sheet 2 of 4)

d. Test intake and exhaust cam heights.

- (1) Use outside micrometer caliper to measure the cam at its highest point. Measurement should be between 1.0563 in. and 1.0583 in. (26.88 mm and 28.83 mm).
- (2) If measurement is out of tolerance, replace camshaft.

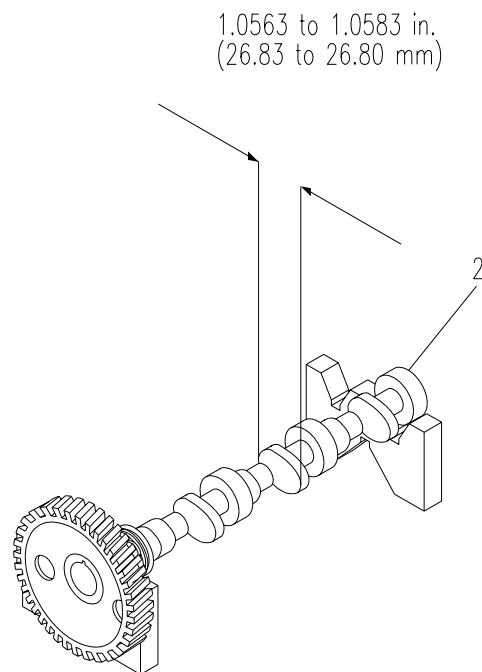

Figure 6-13. Camshaft (Sheet 3 of 4)

REPLACE

- a. Remove two bolts (4) securing camshaft (2) to engine block.
- b. Remove camshaft gear (3), stopper (5), and camshaft (2).
- c. Install new camshaft (2), stopper (5), timing gear (3) and secure with two bolts (4).

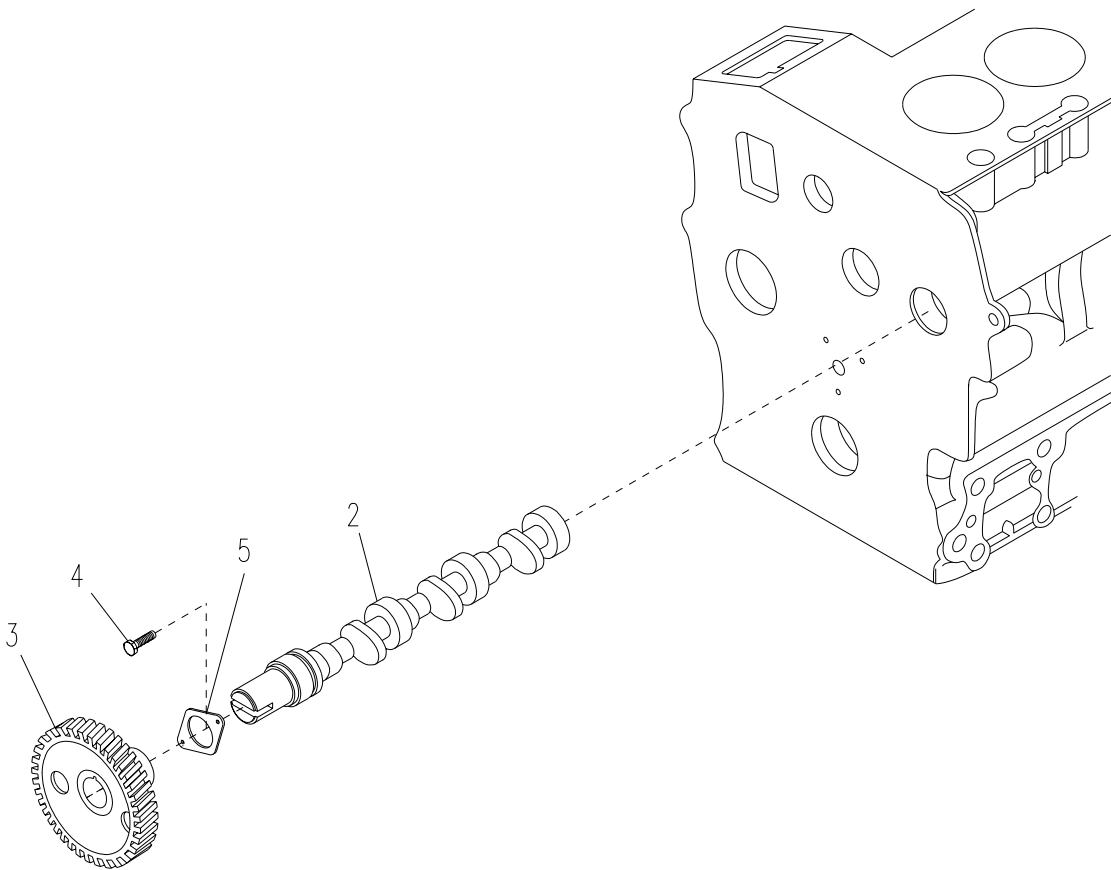

Figure 6-13. Camshaft (Sheet 4 of 4)

6.17. CAMSHAFT GEAR.

This task covers: a. Test b. Replace

INITIAL SETUP

Tools

Special Use Puller Set
(Item 9, Appendix B)

Dial Indicator
(Item 36, Appendix B)

Materials/Parts

Timing Gear

Equipment Conditions

Gear case removed (para 6.12.).

TEST

NOTE

When performing this procedure also check idle gear (para 6.13.), injection pump gear (para 6.19.), and crankshaft gear (para 6.26.).

- a. Set up a dial indicator (1, Figure 6-14) with its tip on a tooth of the camshaft gear (3).
- b. Measure camshaft gear backlash by holding idle gear still while moving camshaft gear.
- c. If backlash exceeds 0.0059 in. (0.15 mm), test oil clearance between idle gear bushing and idle gear (para 6.14.).
 - (1) If oil clearance between idle gear shaft and idle gear bushing is within tolerance, replace camshaft gear.
 - (2) If oil clearance between idle gear shaft and idle gear is out of tolerance, replace idle gear bushing (para 6.14.) or idle gear shaft (para 6.15.) and retest camshaft gear backlash. If backlash still exceeds 0.0059 in. (0.15 mm), replace camshaft gear.

REPLACE

- a. Remove idle gear (para 6.13.).
- b. Use puller set to remove old camshaft gear (3) from camshaft (2).
- c. Install new camshaft gear (3) on camshaft (2).
- d. Ensure that gear is properly aligned (para 6.13.).

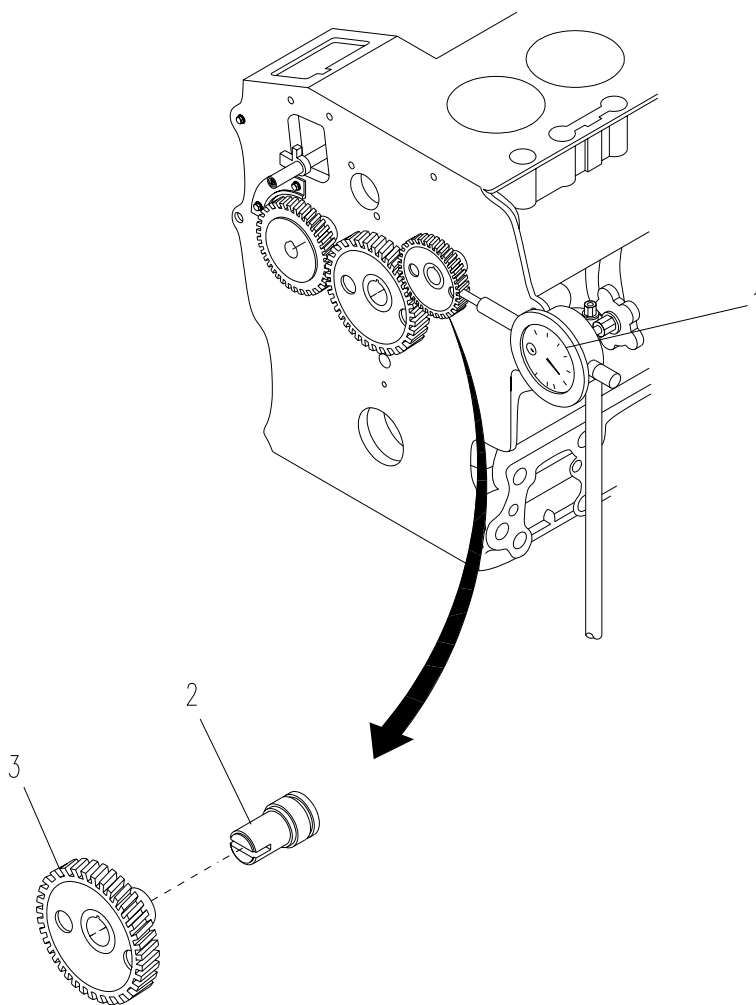

Figure 6-14. Camshaft Gear

6.18. FUEL CAMSHAFT.

This task covers: Replace

INITIAL SETUP

Tools

General Mechanic's Tool Kit
(Item 1, Appendix B)

Equipment Conditions

Camshaft removed (para 6.16.).

Materials/Parts

Fuel Camshaft

REPLACE

- a. Remove two bolts (16, Figure 6-15) and stopper (15).
- b. Remove two bolts (10) securing governor fork holder (9) to engine.
- c. Remove injection pump gear (1), large balls (2), governor sleeve (3), governor ball case and balls (4), and governor sleeve circular clip (5).
- d. Remove spring (7) from fork lever 2 (8) and carefully remove governor fork assembly (6).
- e. Remove bearing case (14), fuel camshaft (13), bearing case (12) and external circular clip (11).
- f. Install external circular clip (11), bearing case (12), new fuel camshaft (13) and bearing case (14).
- g. Install governor fork assembly (6). Carefully install spring (7) to fork lever 2 (8).
- h. Install governor sleeve circular clip (5), governor sleeve ball case and balls (4), governor sleeve (3), large balls (2), and injection pump gear (1).
- i. Secure governor fork holder (9) to engine with two bolts (10).
- j. Secure stopper (15) to engine with two bolts (16).

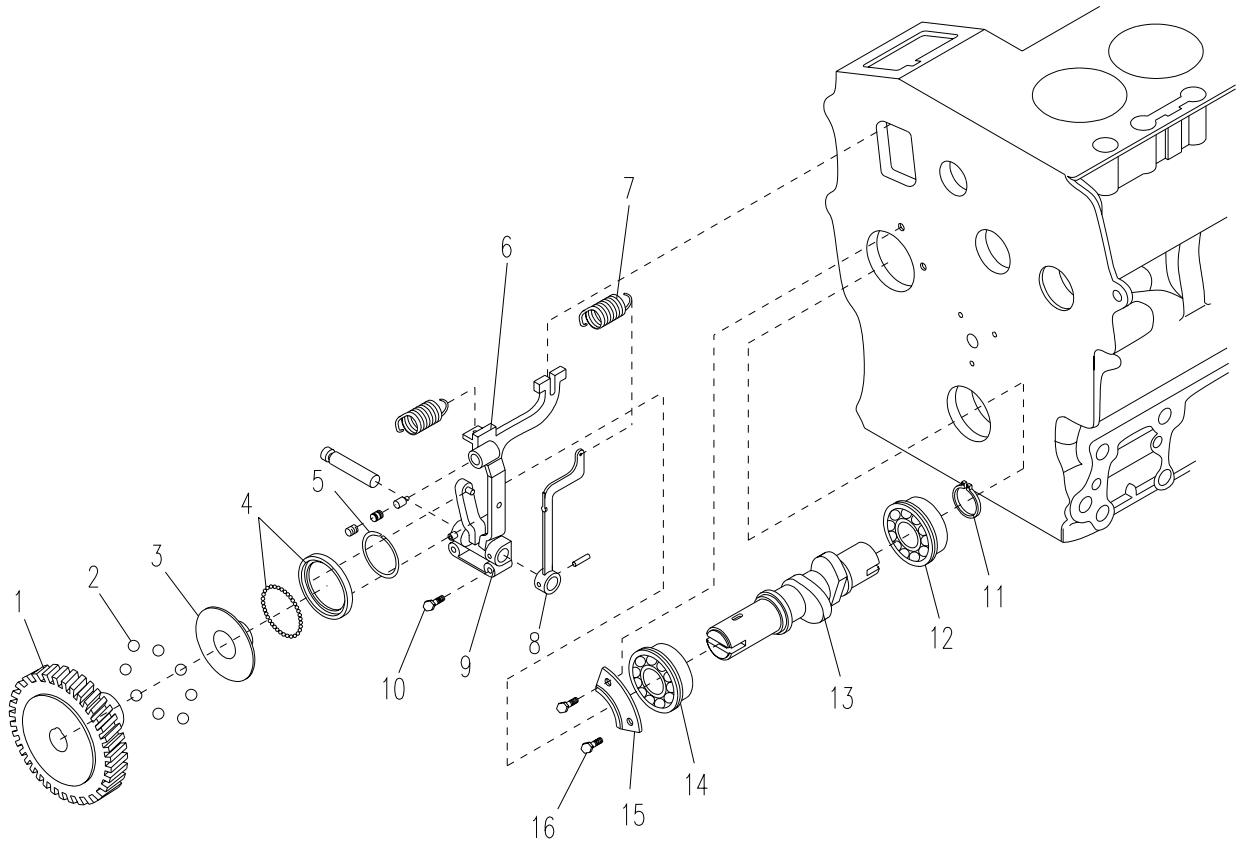

Figure 6-15. Fuel Camshaft

6.19. INJECTION PUMP GEAR.

This task covers: a. Test b. Replace

INITIAL SETUP

ToolsGeneral Mechanic's Tool Kit
(Item 1, Appendix B)Special Use Puller Set
(Item 9, Appendix B)Dial Indicator
(Item 36, Appendix B)Materials/PartsInjection Pump

Equipment Conditions

Gear case removed (para 6.12.).

TEST

NOTE

When performing this procedure, also test idle gear (para 6.13.), camshaft gear (para 6.17.), and crankshaft gear (para 6.20.).

- a. Set up a dial indicator (1, Figure 6-16) with its tip on a tooth of the injection pump gear (3).
- b. Measure injection pump gear backlash by holding idle gear still while moving injection pump gear.
- c. If backlash exceeds 0.0059 in. (0.15 mm), test oil clearance between idle gear bushing and idle gear shaft (para 6.15.).
 - (1) If oil clearance between idle gear shaft and idle gear bushing is within tolerance, replace injection pump gear.
 - (2) If oil clearance between idle gear shaft and idle gear is out of tolerance, replace idle gear bushing (para 6.14.) or idle gear shaft (para 6.15.) and retest injection pump gear backlash. If backlash still exceeds 0.0059 in. (0.15 mm), replace injection pump gear.

REPLACE

- a. Remove idle gear (para 6.13.).
- b. Use special use puller set to remove injection pump gear (3) from fuel camshaft (2).
- c. Install injection pump gear (3) on fuel camshaft (2).
- d. Install idle gear (para 6.13.).
- e. Ensure that gear is properly aligned (para 6.13.).

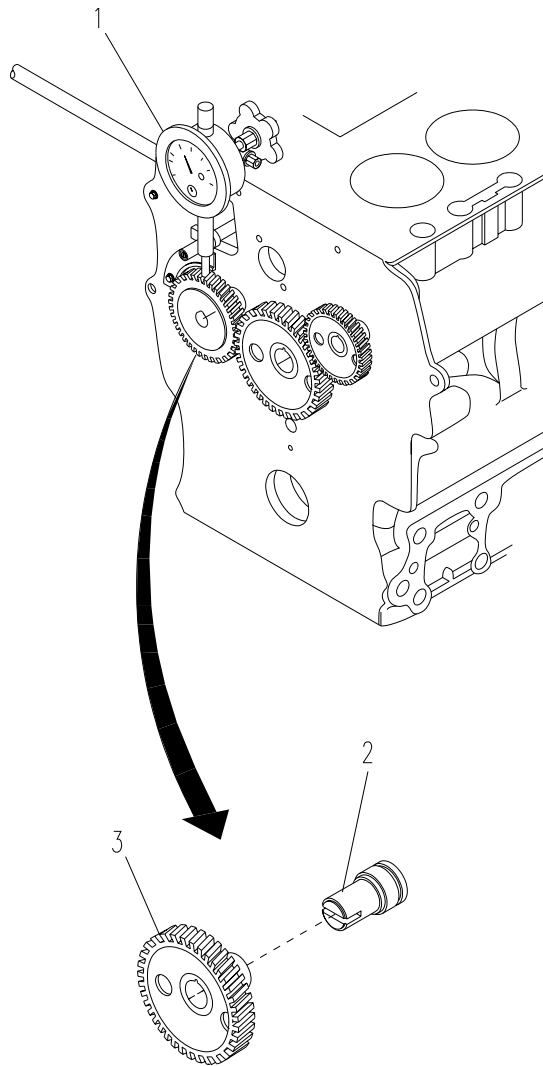

Figure 6-16. Injection Pump Gear

6.20. CRANKSHAFT GEAR.

This task covers: a. Test b. Replace

INITIAL SETUP

ToolsGeneral Mechanic's Tool Kit
(Item 1, Appendix B)Special Use Puller Set
(Item 9, Appendix B)Dial Indicator
(Item 36, Appendix B)Materials/PartsCrankshaft Gear
Collar
Preformed Packing
Oil Slinger

Equipment Conditions

Oil pump gear removed (para 6.31.).

TEST

NOTE

When performing this procedure, check idle gear (para 6.13.), camshaft gear (para 6.17.), and injection pump gear (para 6.19.).

- a. Set up a dial indicator with its tip on a tooth of the crankshaft gear (4, Figure 6-17).
- b. Measure crankshaft gear backlash by holding idle gear still while moving crankshaft gear.
- c. If backlash exceeds 0.0059 in. (0.15 mm), test oil clearance between idle gear bushing and idle gear shaft (para 6.15.).
 - (1) If oil clearance between idle gear shaft and idle gear bushing is within tolerance, replace crankshaft gear.
 - (2) If oil clearance between idle gear shaft and idle gear is out of tolerance, replace idle gear bushing (para 6.14.) or idle gear shaft (para 6.15.) and retest crankshaft gear backlash. If backlash still exceeds 0.0059 in. (0.15 mm), replace crankshaft gear.

REPLACE

- a. Remove idle gear (para 6.13.).
- b. Remove collar (1), preformed packing (2), and oil slinger (3) by hand.
- c. Use special use puller set to remove crankshaft gear (4).
- d. Install crankshaft gear (4).

- e. Install idle gear (para 6.13.).
- f. Ensure that gear is properly aligned (para 6.13.).
- g. Install oil slinger (3), preformed packing (2), and collar (1).

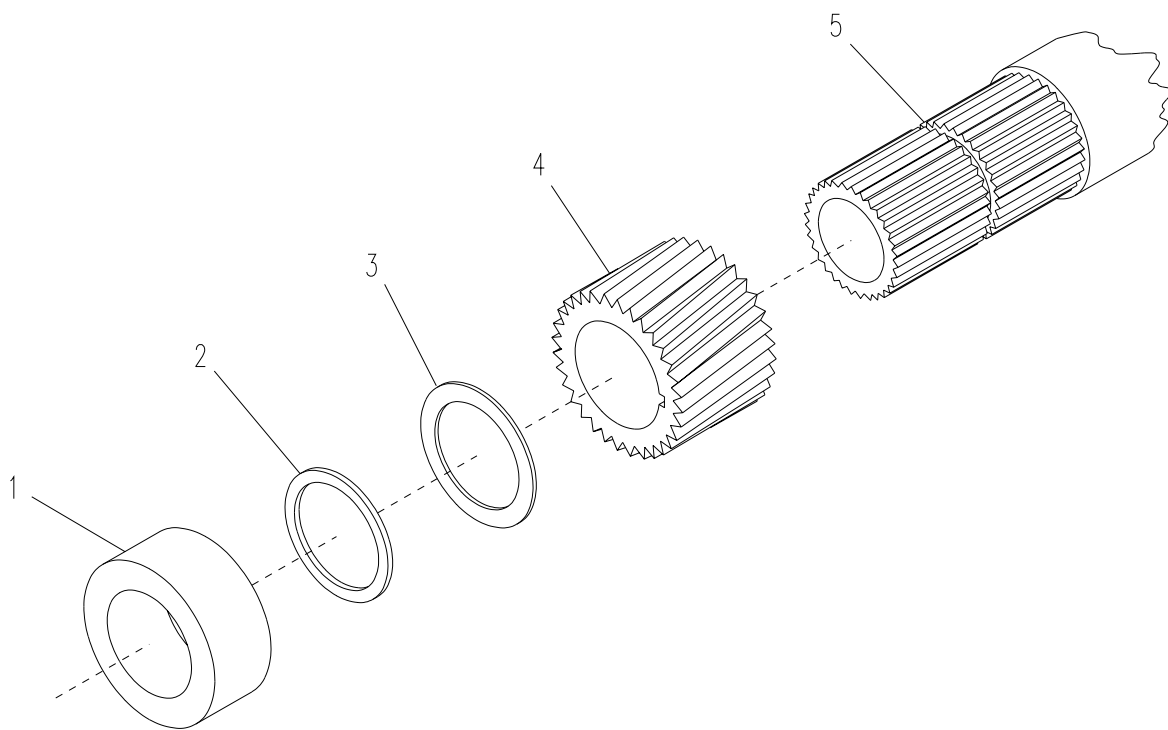

Figure 6-17. Crankshaft Gear

6.21. OIL PUMP GEAR.

This task covers: a. Test b. Replace

INITIAL SETUP

Tools

General Mechanic's Tool Kit
(Item 1, Appendix B)

Dial Indicator
(Item 36, Appendix B)

Materials/Parts

Oil Pump Gear

Equipment Conditions

Gear case removed (para 6.12.).

TEST

- a. Set up a dial indicator with its tip on a tooth of the oil pump gear (2, Figure 6-18).
- b. Measure oil pump gear backlash by holding crankshaft gear still while moving oil pump assembly.
- c. If backlash exceeds 0.0059 in. (0.15 mm), replace oil pump gear.

REPLACE

- a. Remove one nut (1) and remove oil pump gear (2).
- b. Install oil pump gear (2) and secure with nut (1).

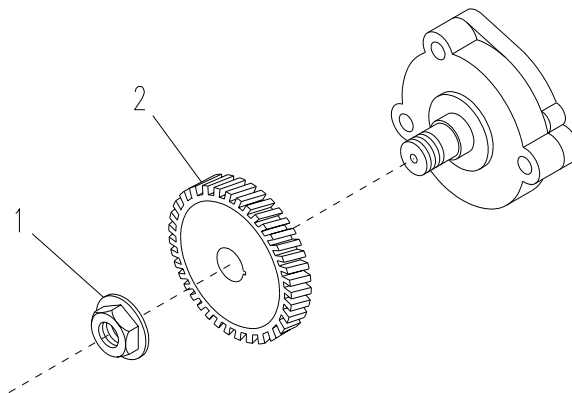

Figure 6-18. Oil Pump Gear

6.22. PISTONS.

This task covers: a. Test b. Replace

INITIAL SETUP

Tools

General Mechanic's Tool Kit
(Item 1, Appendix B)

Inside Micrometer Caliper
(Item 42, Appendix B)

Piston Ring Compressor
(Item 41, Appendix B)

Materials/Parts

Lubricating Oil
(Items 10-13, Appendix F)

Piston

Equipment Conditions

Oil pan strainer removed (para 5.9.).
Cylinder head removed (para 6.5.).

TEST

CAUTIONS

- Install piston ONLY into the same cylinder it was removed from.
 - Pistons are not symmetrical. Make sure piston is aligned in cylinder properly.
-
- a. Remove piston from cylinder (perform steps a - d of REPLACE).
 - b. Remove connecting rod from piston (perform steps a - b of REPLACE, para 6.23.).
 - c. Use inside micrometer caliper to measure the ID of the piston pinbore in both the horizontal and vertical positions. It should measure between 0.78740 and 0.78791 in. (20.000 and 20.013 mm).
 - d. If piston pinbore exceeds 0.7894 in. (20.05 mm), replace piston.

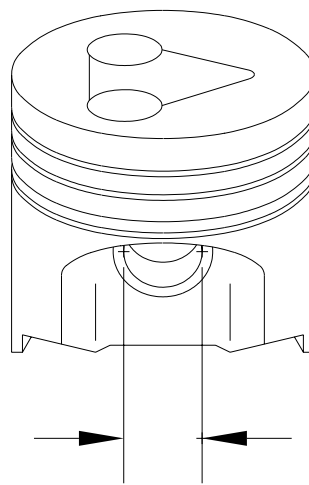

0.78740 TO 0.78791 IN.
(20.000 TO 20.013 mm.)

Figure 6-19. Piston (Sheet 1 of 2)

REPLACE

- a. Remove two bolts (3) securing connecting rod cap (4) to connecting rod (1).

CAUTION

Use retaining nut on crankshaft pulley to turn crankshaft. Do not turn crankshaft by any other means.

- b. Bring the piston (5) to top dead center by turning the crankshaft.
- c. Use the grip of a hammer to push the connecting rod (1) from the bottom of the cylinder until piston (5) emerges from cylinder.
- d. Pull piston (5) out from cylinder by hand.
- e. Apply lubricating oil to the inside surface of the cylinder.
- f. Apply lubricating oil to the crank pin bearings and connecting rod screws (3).

CAUTIONS

- When installing piston, the number engraved on the piston head (6) must be positioned on the side of the engine opposite the injection pump.
 - Piston rings must be properly aligned. See para 6.24., REPLACE, for alignment of piston rings.
- g. Align rings and use piston ring compressor to compress rings, install piston (5) and connecting rod (1) into the cylinder.
 - h. Align marks (2) on connecting rod (1) and connecting rod cap (4) and install connecting rod cap (4) with two bolts (3). Torque between 19.5 and 22.4 ft-lbs (26.5 to 30.4 Nm).

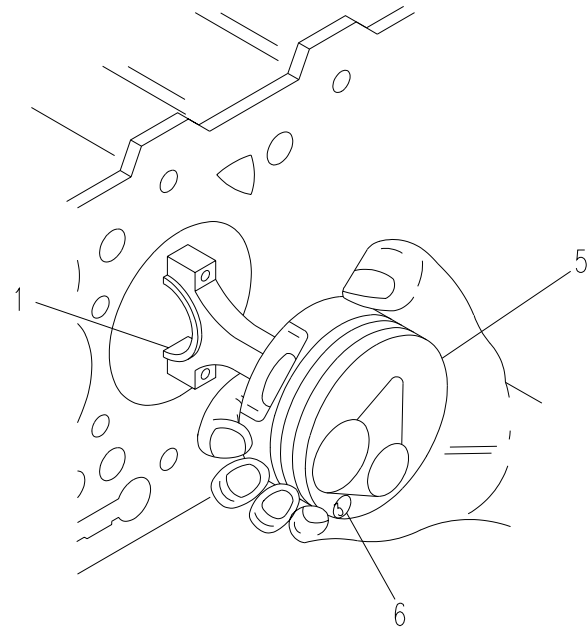
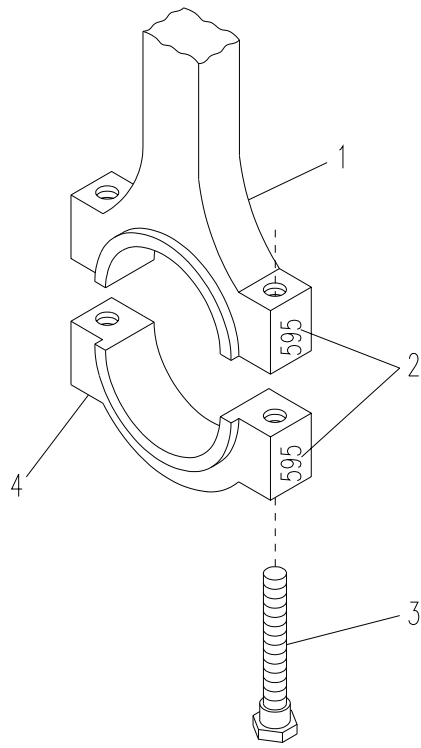

Figure 6-19. Piston (Sheet 2 of 2)

6.23. CONNECTING ROD.

This task covers: a. Test b. Repair c. Replace

INITIAL SETUP

Tools

General Mechanic's Tool Kit
(Item 1, Appendix B)

Inside Micrometer Caliper
(Item 42, Appendix B)

Outside Micrometer Caliper
(Item 43, Appendix B)

Connecting Rod Alignment Tool
(Item 14, Appendix B)

Connecting Rod Small End Bushing Tool
(Item 17, Appendix B)

Materials/Parts

Connecting Rod
Small End Bushing
Piston Pin
Crankpin Bearing

Equipment Conditions

Piston removed from cylinder (para 6.22.).

TEST

- a. Remove connecting rod from piston (perform steps a and b of REPLACE).
- b. Test oil clearance between piston pin and small end bushing.
 - (1) Use outside micrometer caliper to measure the OD of the piston pin where it contacts the bushing. OD should be between 0.78748 and 0.78783 in. (20.002 and 20.011 mm) (Sheet 1).
 - (2) Use inside micrometer caliper to measure the ID of the small end bushing. ID should be between 0.78839 and 0.78897 in. (20.025 and 20.040 mm) (Sheet 1).
 - (3) Calculate the oil clearance.
 - (4) If oil clearance exceeds 0.0039 in. (0.10 mm), repair connecting rod by replacing small end bushing.
 - (5) Recalculate the oil clearance. If it still exceeds 0.0039 in. (0.10 mm), replace the piston pin.

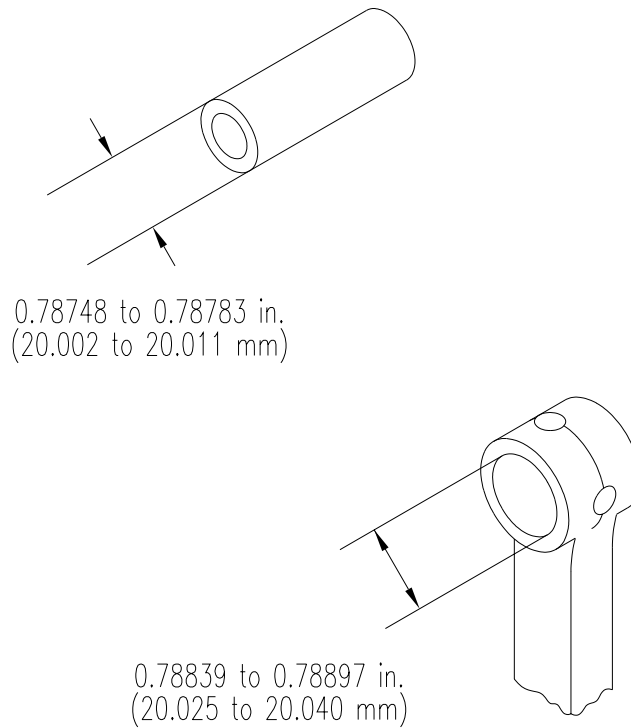

Figure 6-20. Connecting Rod (Sheet 1 of 4)

c. Test connecting rod alignment.

- (1) Install connecting rod cap to connecting rod (para 6.28., REPLACE, step h).
- (2) Refer to Figure 6-20 (sheet 2) and install connecting rod to connecting rod alignment tool.
- (3) Install piston pin (1, Figure 6-20 (sheet 4)) in connecting rod and set gauge on pin (Figure 6-20, sheet 2).
- (4) Refer to Figure 6-20 (sheet 2) and measure the gaps of the three points between the pins and the flat surface of the alignment tool.
- (5) Gaps should not exceed 0.0020 in. (0.05 mm). If gap exceeds tolerance, replace connecting rod.

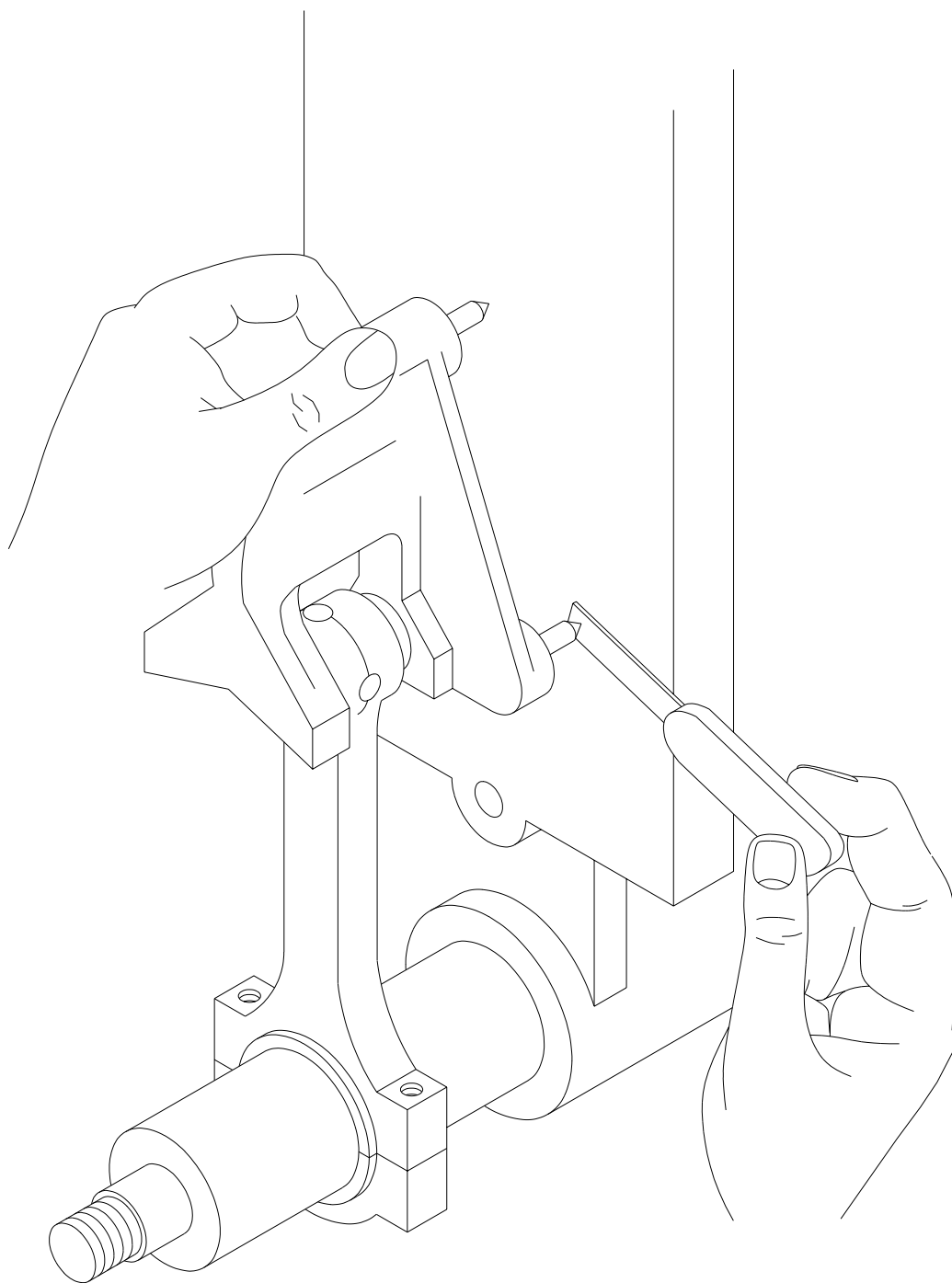

Figure 6-20. Connecting Rod (Sheet 2 of 4)

REPAIR

- a. Use small end bushing tool to remove small end bushing (1, Figure 6-20) from connecting rod (2).
- b. Use small end bushing tool to install new small end bushing (1) into connecting rod (2).

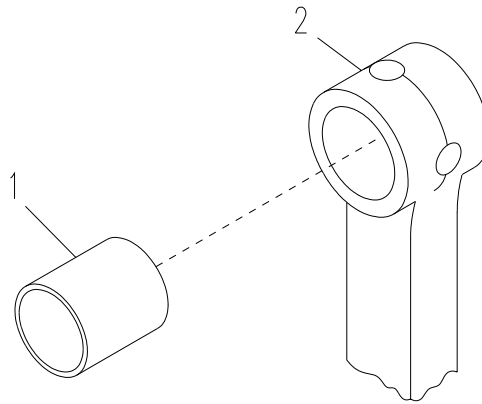

Figure 6-20. Connecting Rod (Sheet 3)

REPLACE

- a. Remove two snap rings (3) from piston pin (1), Figure 6-20, Sheet 4.
- b. Remove piston pin (1) and connecting rod (2) from piston (4).
- c. Install connecting rod (2) in piston (4) and secure with piston pin (1).
- d. Secure piston pin (1) with two snap rings (3).

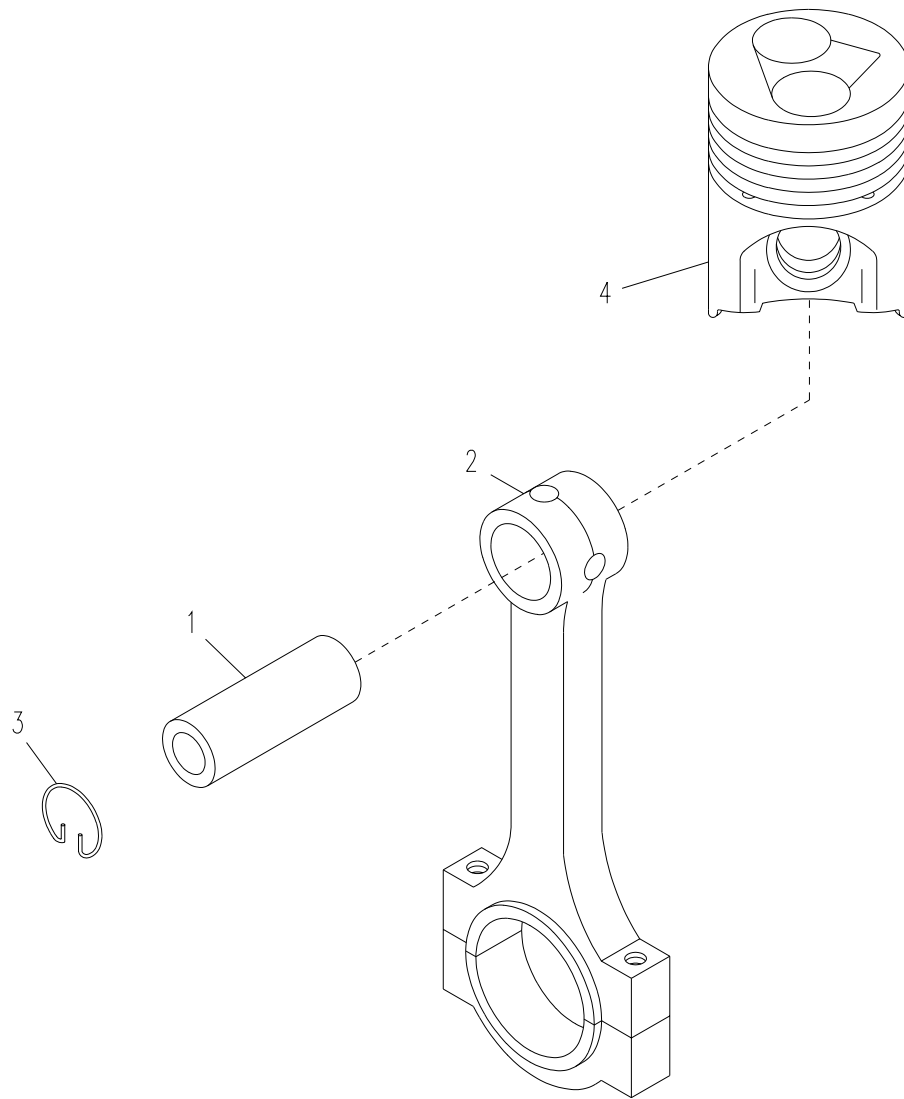

Figure 6-20. Connecting Rod (Sheet 4)

6.24. PISTON RINGS.

This task covers: a. Test b. Replace

INITIAL SETUP

Tools

General Mechanic's Tool Kit
(Item 1, Appendix B)

Piston Ring Expander
(Item 40, Appendix B)

Piston Compressor
(Item 41, Appendix B)

Materials/Parts

Piston Rings

TEST

NOTE

Ensure that piston rings are reinstalled on same piston from which they were removed from (Figure 6-21, Sheets 3 and 4).

- a. Remove piston ring from piston (perform step a of REPLACE).
- b. Test piston ring gap.
 - (1) Use piston compressor and piston to insert compression ring 1 into the least worn out part of the cylinder.
 - (2) Measure the ring gap.
 - (3) If gap exceeds 0.0472 in. (1.2 mm), replace ring.
 - (4) Perform step 1 with compression ring 2 and measure ring gap.
 - (5) If gap exceeds 0.0472 in. (1.2 mm), replace ring.

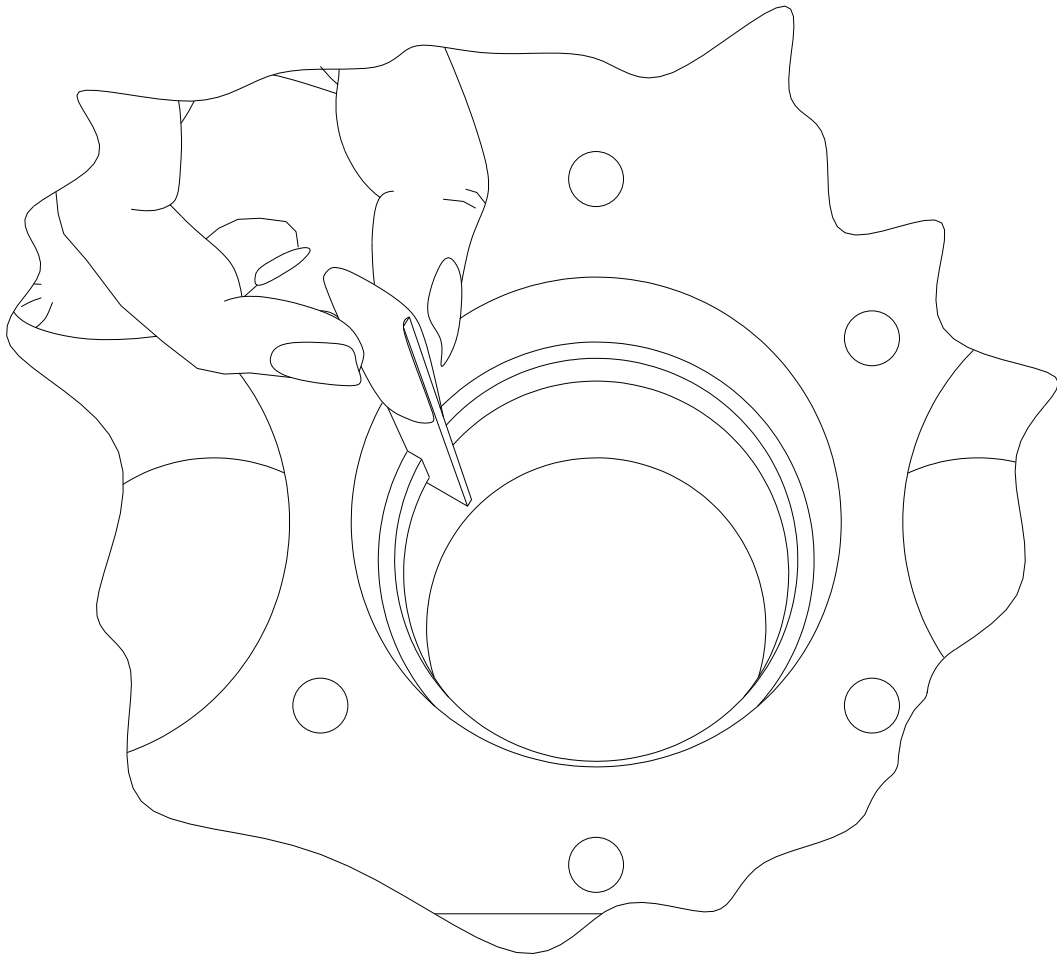

Figure 6-21. Piston Rings (Sheet 1 of 4)

NOTE

Install rings into same groove from which they were removed from.

NOTE

When installing piston rings, ensure that manufacturer's mark (5), near gap, faces up.

c. Test clearance between piston rings and grooves.

- (1) Remove carbon from grooves.
- (2) Place compression ring 1 in groove and measure clearance at several points around ring.
- (3) If clearance exceeds 0.0059 in. (0.15 mm), replace compression ring.

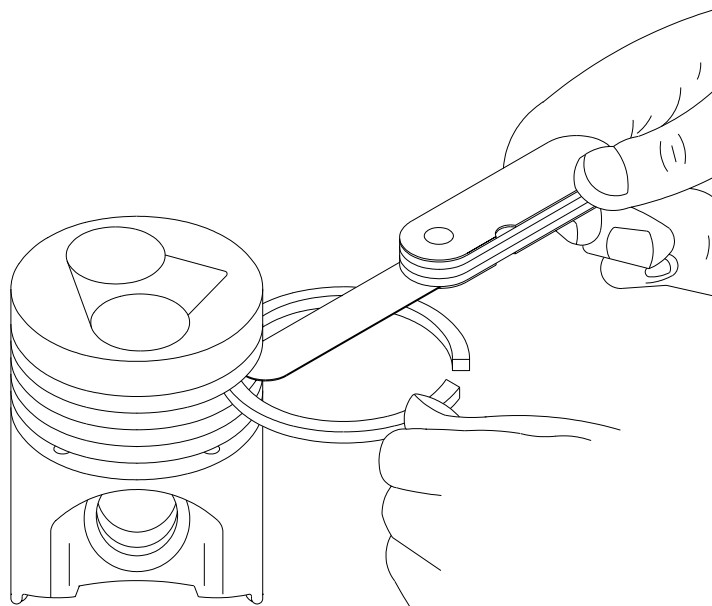

Figure 6-21. Piston Rings (Sheet 2 of 4)

- (4) Perform steps 1 - 3 with compression ring 2.
- (5) Place oil ring in groove and measure clearance.
- (6) If clearance exceeds 0.0059 in. (0.15 mm), replace oil ring.

REPLACE

- a. Use piston ring expander to remove two compression rings (1 and 2, Figure 6-21), Sheet 3, expander joint (3), and oil ring (4).

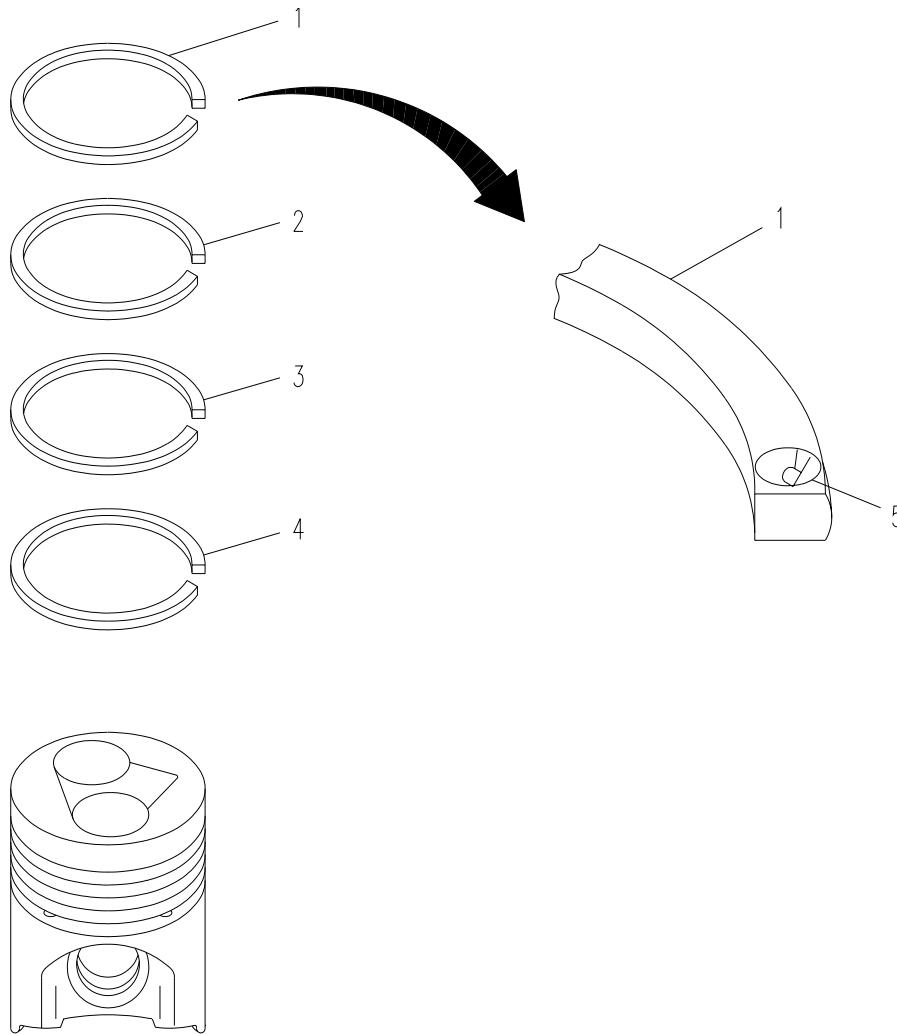

Figure 6-21. Piston Rings (Sheet 3 of 4)

- b. Refer to Figure 6-21 (sheets 3 and 4) and use ring expander to install two compression rings (1 and 2), expander joint (3), and oil ring (4). Proceed as follows:

NOTE

When installing compression ring 1, ensure that the gap is on the side opposite of the combustion chamber.

- (1) Install compression ring 1 (1). Place gap on opposite side of combustion chamber.
- (2) Install compression ring 2 (2). Place gap 90° ccw of compression ring 1 gap.
- (3) Install expander (3). Place expander joint 45° ccw of compression ring 1 gap.
- (4) Install oil ring (4). Place gap 180° ccw of expander joint.

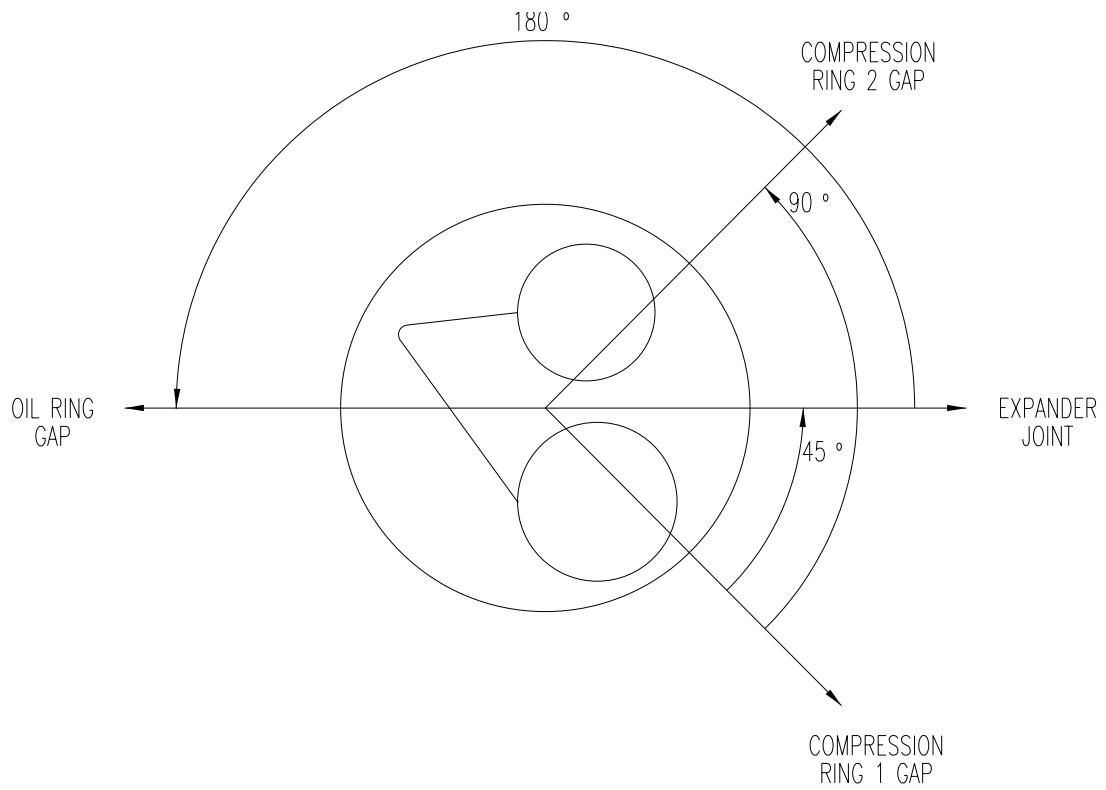

Figure 6-21. Piston Rings (Sheet 4 of 4)

6.25. BEARING CASE COVER.

This task covers: Replace

INITIAL SETUP

Tools

General Mechanic's Tool Kit
(Item 1, Appendix B)

Equipment Conditions

Flywheel removed (para 5.38).

Materials/Parts

Sealing Compound
(Item 18, Appendix B)

Bearing Case Cover

Bearing Case Cover Gasket
(Item 1, Appendix J)

REPLACE

- a. Remove ten bolts (1, Figure 6-22) and remove bell housing (2).
- b. Remove sixteen bolts (3) securing bearing case cover (4) to engine (6).
- c. Install two of the bolts (3) removed in step b into two bolt holes (7) on either side of cover (4).
- d. Remove cover (4) by pulling on two bolts (3).
- e. Remove two bolts (3) from cover (4).
- f. Remove gasket (5) from cover.
- g. Apply sealing compound to both sides of new gasket (5) and install new gasket (5) on cover (4).

NOTE

Ensure that the up-arrow casting mark on bearing case cover is pointing up.

- h. Install cover (4) and secure with sixteen bolts (3). Torque bolts between 7.23 and 8.32 ft-lbs (9.81 to 11.28 Nm).
- i. Install bell housing (2) and secure with 10 bolts (1).

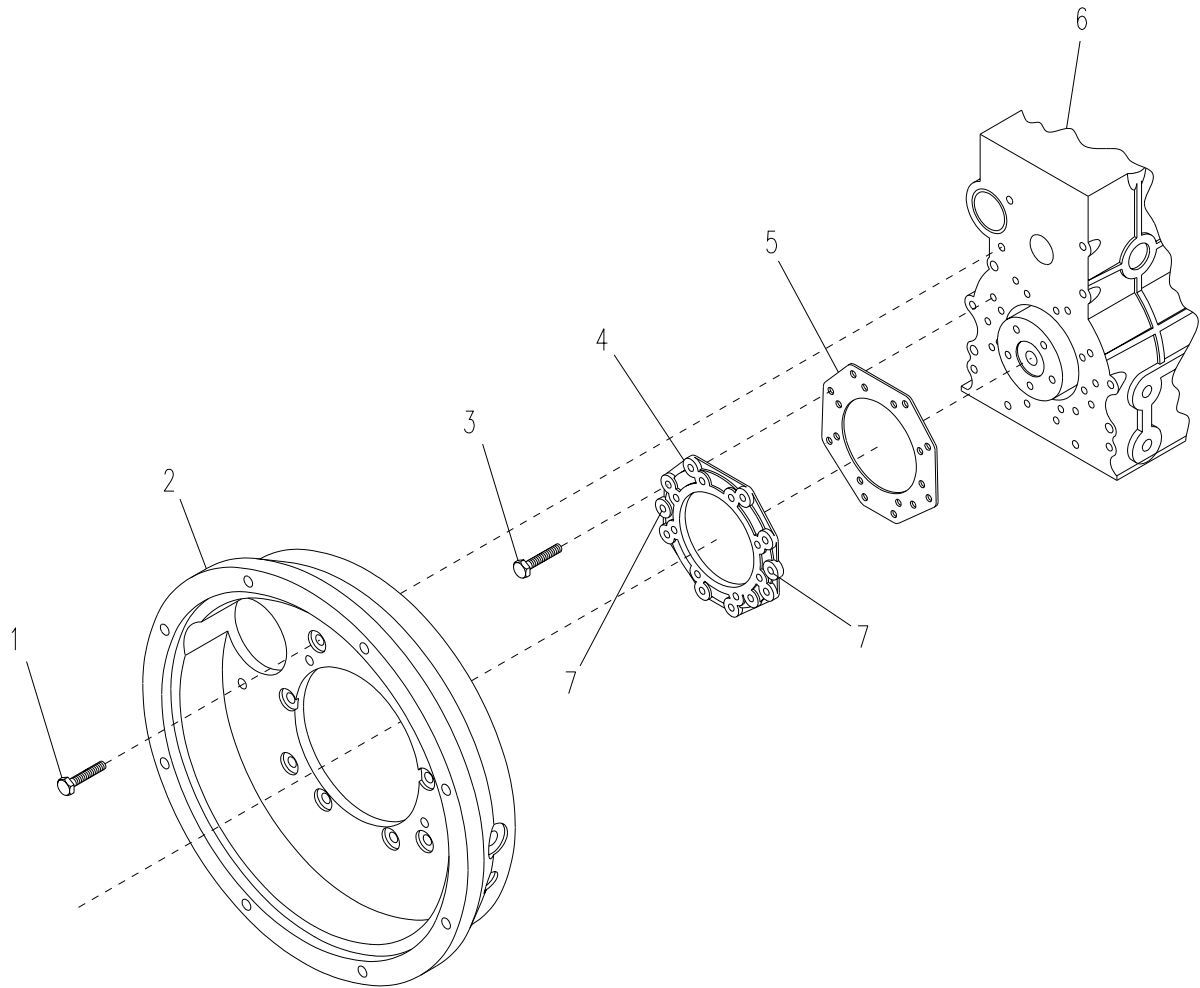

Figure 6-22. Bearing Case Cover

6.26. CRANKSHAFT.

This task covers: a. Test b. Replace

INITIAL SETUP

Tools

General Mechanic's Tool Kit
(Item 1, Appendix B)

Dial Indicator
(Item 36, Appendix B)

Materials/Parts

Crankshaft

Bearing Case Gasket
(Item 19, Appendix J)

Equipment Conditions

Bearing case cover removed (para 6.25.).

Piston removed (para 6.22.).

TEST

NOTE

When performing this procedure, check camshaft bearing (para 6.28. and/or 6.29.).

a. Test end clearance.

- (1) Set tip of dial indicator on the end of the crankshaft.
- (2) Measure end clearance by moving the crankshaft front and rear. Side clearance should be between 0.0059 and 0.0122 in. (0.15 and 0.31 mm).
- (3) If end clearance exceeds 0.020 in. (0.5 mm), replace thrust bearing (perform steps c and e of REPLACE). Refer to Appendix C and replace with an oversize bearing if necessary.

b. Test alignment.

- (1) Remove crankshaft from engine (perform steps a - d of REPLACE).
- (2) Support the crankshaft on suitable supports.
- (3) Place tip of dial indicator at a right angle on middle journal.
- (4) Check for misalignment by rotating crankshaft. If misalignment exceeds 0.0008 in. (0.02 mm), replace crankshaft.

REPLACE

- a. Remove two bolts (1, Figure 6-23) securing bearing case assembly 2 and bearing case assembly 3 to engine.
- b. Remove crankshaft from engine (2).
- c. Remove bearing case gasket (3).
- d. Remove one bolt (4), bearing case assembly 1 (5), and thrust bearings (6).
- e. Remove two bolts (11 and 12), remove bearing case assemblies 2 and 3 (7 and 10) and crankshaft bearings 2 and 3 (8 and 9).

CAUTION

Install crankshaft bearings into original positions. THEY ARE NOT INTERCHANGEABLE.

NOTE

When installing bearing case assemblies 2 and 3, face the "FLYWHEEL" mark towards the flywheel.

NOTE

Apply lubricating oil to a crankshaft bearing 2 and thrust bearing before installation.

NOTE

Install thrust bearing with oil groove facing outward.

- f. Install thrust bearing (6) and bearing case assembly 1 (5). Secure with two bolts (4).
- g. Install crankshaft bearings 2 and 3 (8 and 9) and bearing case assemblies 2 and 3 (7 and 10). Secure with two bolts (11 and 12).
- h. Install bearing case gasket (3).
- i. Install crankshaft (2).
- j. Secure bearing case 2 and bearing case 3 to engine with two bolts (1).

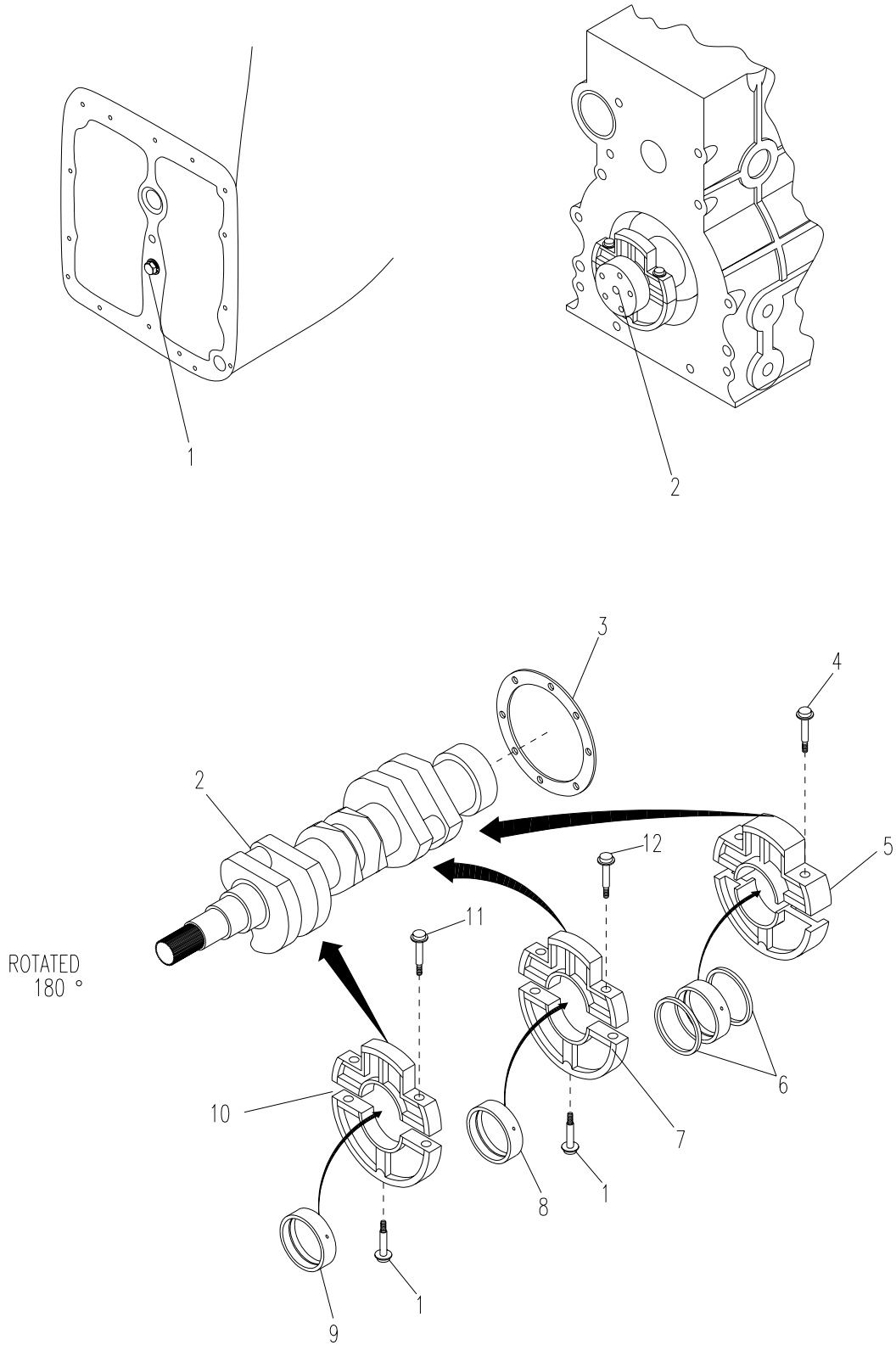

Figure 6-23. Crankshaft

6.27. CONNECTING ROD BEARING.

This task covers: a. Test b. Replace

INITIAL SETUP

Tools

General Mechanic's Tool Kit
(Item 1, Appendix B)

Equipment Conditions

Piston removed (para 6.22.).

Materials/Parts

Gage, Bearing Clearance (Plastigage)
(Item 7, Appendix F)

Connecting Rod

TEST

- a. Clean connecting rod and connecting rod bearing.

CAUTION

Do not press Plastigage into the connecting rod oil hole.

- b. Place a strip of Plastigage on the center of the connecting rod.
- c. Install piston and connecting rod (para 6.22.).
- d. Remove two bolts and remove connecting rod cap.
- e. Measure oil clearance by measuring amount of Plastigage strip flattening.
- f. If the oil clearance exceeds 0.0059 in. (0.15 mm), replace connecting rod bearing. Refer to Table 6-1 and Appendix C and replace with an undersize bearing if necessary.

Table 6-1. Undersize Connecting Rod Bearing

Connecting Rod OD	Undersize Connecting Rod Bearing
1.32910 to 1.32122 in. (33.759 to 33.775 mm)	0.008 in. (0.2 mm)
1.32122 to 1.32185 in. (33.559 to 33.575 mm)	0.016 in. (0.4 mm)

REPLACE

- a. Remove connecting rod bearing (1, Figure 6-24) from connecting rod (2).
- b. Install connecting rod bearing (1) on connecting rod (2).

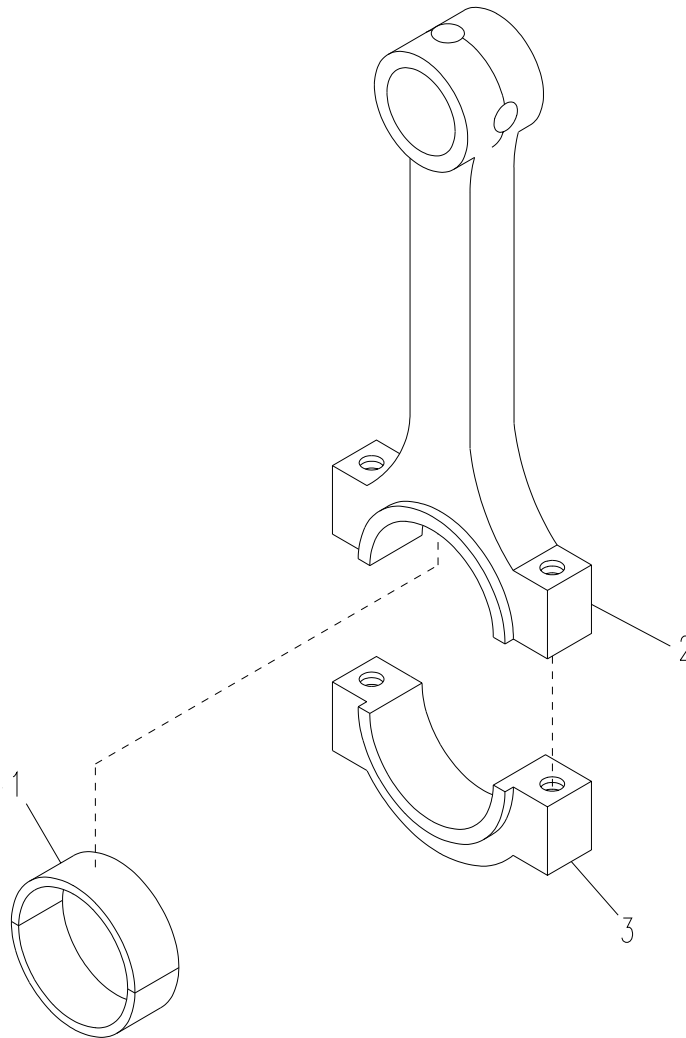

Figure 6-24. Connecting Rod Bearing

6.28. CRANKSHAFT BEARING 1.

This task covers: a. Test b. Replace

INITIAL SETUP

Tools

Inside Micrometer Caliper
(Item 47, Appendix B)

Outside Micrometer Caliper
(Item 48, Appendix B)

Crankshaft Bearing 1 Replacing Tool
(Item 16, Appendix B)

Equipment Conditions

Crankshaft bearing case 1 removed from crankshaft (para 6.25.).

Materials/Parts

Crankshaft Bearing 1

TEST

- a. Refer to Figure 6-25 (sheet 1) and use inside micrometer caliper to measure the ID of crankshaft bearing 1. ID should be between 1.57418 and 1.57638 in. (33.984 and 40.040 mm).
- b. Use outside micrometer caliper to measure the OD of crankshaft journal. OD should be between 1.57221 and 1.57284 in. (33.934 and 39.950 mm).
- c. Calculate oil clearance. Oil clearance should be between 0.00134 and 0.00417 in. (0.034 and 0.016mm).
- d. If oil clearance exceeds 0.0079 in. (0.20 mm), replace bearing. Refer to Table 6-2 and Appendix C and replace with an undersize bearing if necessary.

Table 6-2. Undersize Crankshaft Bearing I

Crankshaft Journal OD	Undersize Crankshaft Bearing I
1.56433 to 1.56496 in. (39.734 to 39.750 mm)	0.008 in. (0.2 mm)
1.55646 to 1.55709 in. (39.534 to 39.550 mm)	0.016 in. (0.4 mm)

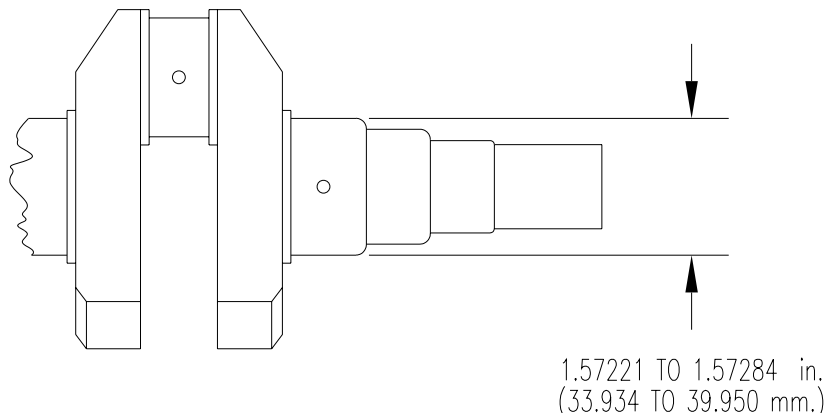
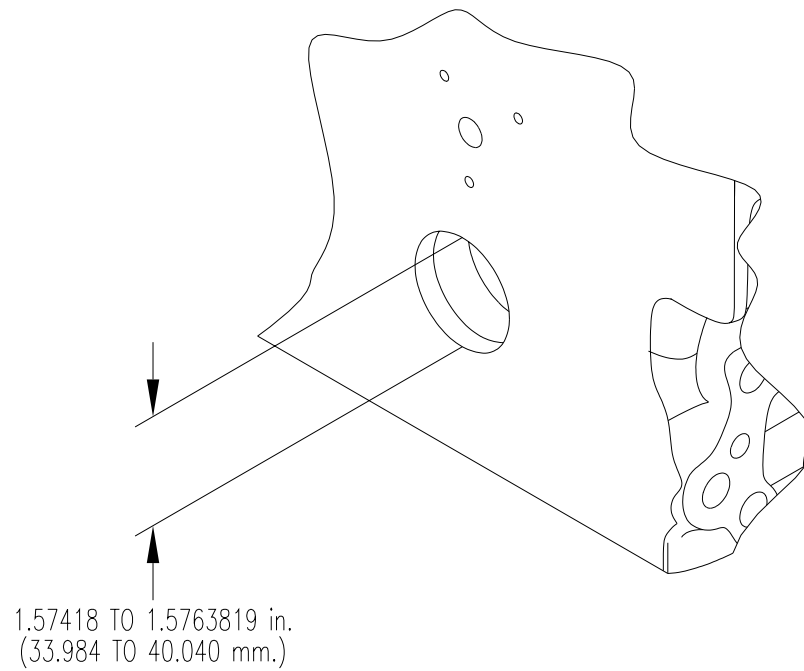

Figure 6-25. Crankshaft Bearing 1 (Sheet 1 of 2)

REPLACE

- a. Use crankshaft bearing 1 replacing tool to remove old crankshaft bearing 1 (3).

NOTE

Chamfer oil hole (2) on Crankshaft Journal (1) before installing crankshaft bearing 1 (3).

NOTE

Ensure that seam (5) of bearing (3) faces exhaust side of cylinder block (4).

- b. Use crankshaft bearing 1 replacing tool to install new crankshaft bearing 1 (3). Allow no more than 0.012 in. gap between face of cylinder block (4) and crankshaft bearing 1 (3).

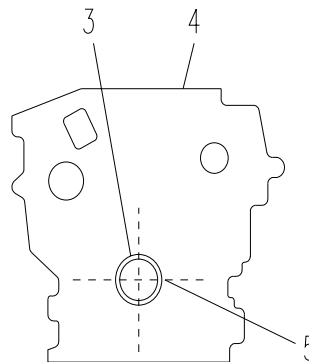
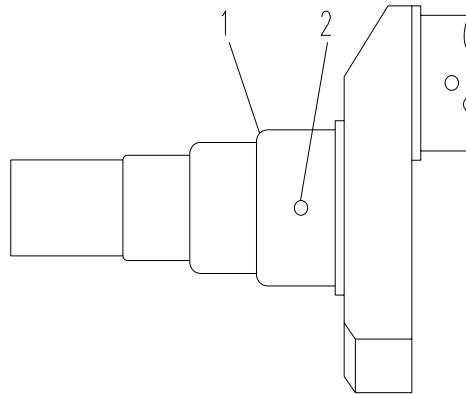

Figure 6-25. Crankshaft Bearing 1 (Sheet 2)

6.29. CRANKSHAFT BEARINGS 2 AND 3.

This task covers: a. Test b. Replace

INITIAL SETUP

Tools

General Mechanic's Tool Kit
(Item 1, Appendix B)

Equipment Conditions

Crankshaft bearing case 2 and 3 removed from crankshaft (para 6.26.).

Materials/Parts

Gage, Bearing Clearance (Plastigage)
(Item 6, Appendix F)

Crankshaft Bearing 2
Crankshaft Bearing 3

TEST

- a. Place a strip of Plastigage on center of crankshaft journal.

NOTE

Do not move crankshaft while securing bearing case assembly.

- b. Install the bearing case assembly and secure with one bolt (para 6.25.). Torque between 9.4 and 11.6 ft-lbs (12.75Nm and 15.7Nm).
- c. Remove bearing case (para 6.25.) and measure oil clearance by measuring amount of Plastigage strip flattening. Oil clearance should be between 0.00134 and 0.00362 in. (0.034 and 0.092 mm).
- d. If oil clearance exceeds 0.0079 in. (0.20 mm), replace bearing. Refer to Table 6-3 and Appendix C and replace with undersize bearing if necessary.

Table 6-3. Undersize Crankshaft Bearings 2 and 3

Crankshaft Journal 2 OD	Crankshaft Journal 3 OD	Crankshaft Bearing
1.56433 to 1.56496 in. (39.734 to 39.750 mm)	1.72181 to 1.72244 in. (43.734 to 43.750 mm)	0.008 in. (0.2 mm)
1.55646 to 1.55709 in. (39.534 to 39.550 mm)	1.71394 to 1.71457 in. (43.534 to 43.550 mm)	0.016 in. (0.4 mm)

REPLACE

- a. Remove bearing (1, Figure 6-26) from bearing case assembly (2).
- b. Install bearing (1) in bearing case assembly (2).

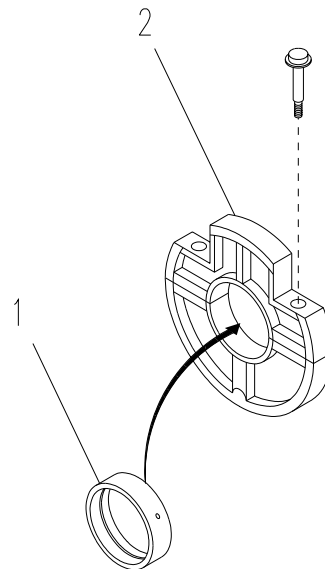

Figure 6-26. Crankshaft Bearings 2 and 3

6.30. CYLINDER.

This task covers: a. Test b. Adjust

INITIAL SETUP

Tools

General Mechanic's Tool Kit
(Item 1, Appendix B)

Cylinder Gage
(Item 39, Appendix B)

Boring Tool Bar
(Item 49, Appendix B)

Cylinder Hone Stone and Holder
(Item 45, Appendix B)

Materials/Parts

None.

Equipment Conditions

Crankshaft removed from crankcase (para 6.26.).

TEST

- a. Refer to Figure 6-27 and use cylinder gage to measure cylinder ID at the following depths:

NOTE

At each depth, measure cylinder ID in two different directions: parallel to the piston pin and perpendicular to the piston pin.

- (1) 0.394 in. (10 mm)
- (2) 1.771 in. (45 mm)
- (3) 3.740 in. (90 mm)

- b. Cylinder ID should be between 2.63779 and 2.63854 in. (67.000 and 67.019 mm).
- c. From the six measurements, determine the maximum wear by calculating the difference between the largest and smallest ID.
- d. If maximum wear is greater than 0.0059 in. (0.15 mm), adjust the cylinder.

ADJUST

- a. Bore and hone cylinder to obtain an ID 2.64764 to 2.64839 in. (67.250 to 67.269 mm).
- b. Refer to Appendix C and replace pistons with oversize pistons (para 6.28.) and rings (para 6.24.).

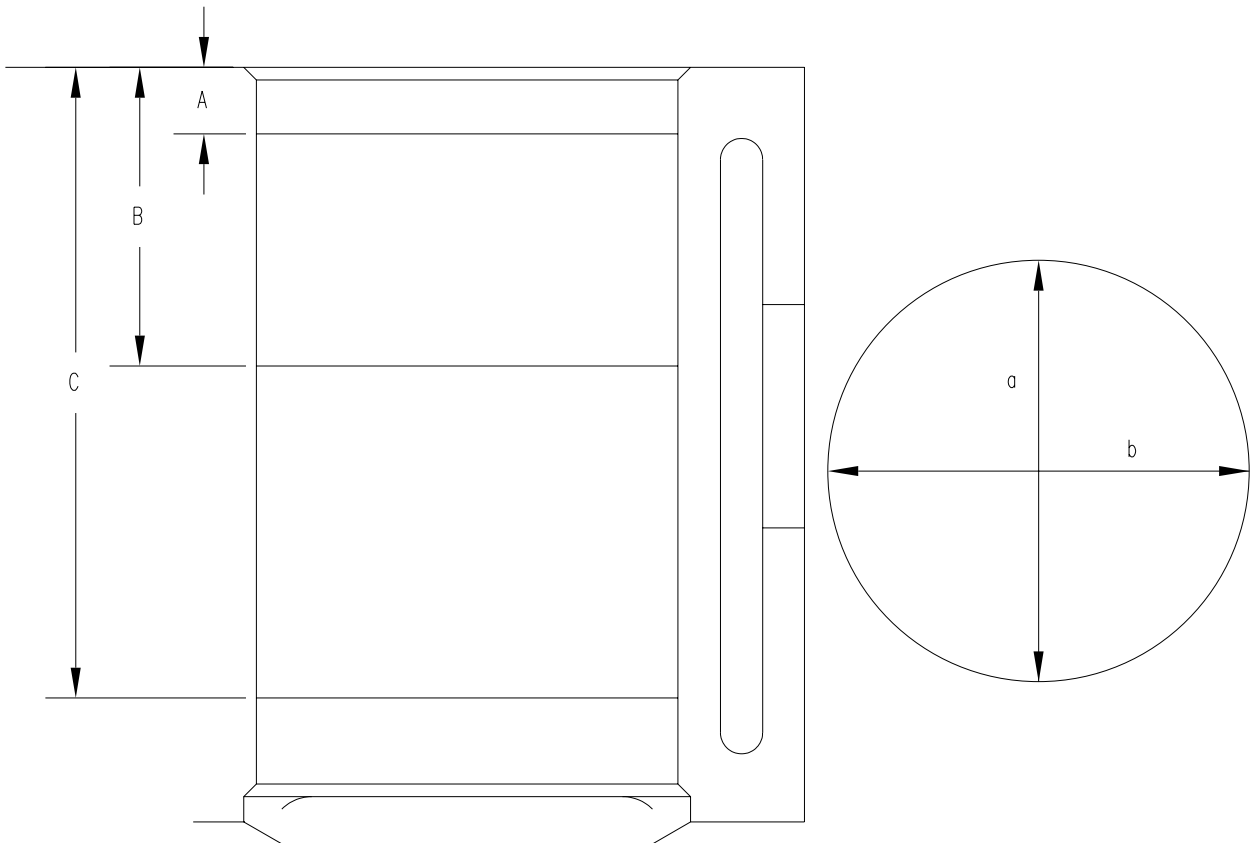

- A. Approx. 0.394 in. (10mm.)
- B. Approx. 1.771 in. (45mm.)
- C. Approx. 3.740 in. (90mm.)
- a. Perpendicular to piston pin
- b. Parallel to piston pin

Figure 6-27. Cylinder

6.31. OIL PUMP ASSEMBLY.

This task covers: a. Test b. Replace

INITIAL SETUP

Tools

General Mechanic's Tool Kit
(Item 1, Appendix B)

Equipment Conditions

Oil pump gear removed (para 6.21.).

Materials/Parts

Gage, Bearing Clearance (Plastigage)
(Item 7, Appendix F)

Oil Pump Rotor Assembly

Oil Pump Gasket
(Item 9, Appendix J)

TEST

- a. Remove oil pump assembly (1, Figure 6-28) (perform step a of REPLACE).
- b. Measure the clearance between lobes of inner rotor (3) and outer rotor (2). Clearance should be between 0.012 and 0.0055 in. (0.03 and 0.14 mm).
- c. If clearance is out of tolerance, replace oil pump assembly (1).
- d. Measure clearance between outer rotor (2) and pump body. Clearance should be between 0.0028 and 0.0059 in. (0.07 and 0.15 mm).
- e. If clearance is out of tolerance, replace oil pump assembly (1).
- f. Measure clearance between inner rotor and cover.
 - (1) Remove inner rotor (3) from cover.
 - (2) Place a strip of plastigage on rotor (3).
 - (3) Install rotor (3) in cover.
 - (4) Install, then remove, oil pump assembly (1) (perform steps a and b of REPLACE).
 - (5) Remove inner rotor (3) from cover and measure plastigage to find clearance. Clearance should be between 0.0029 and 0.0053 in. (0.075 and 0.135 mm).
 - (6) If clearance is out of tolerance, replace oil pump assembly (1).

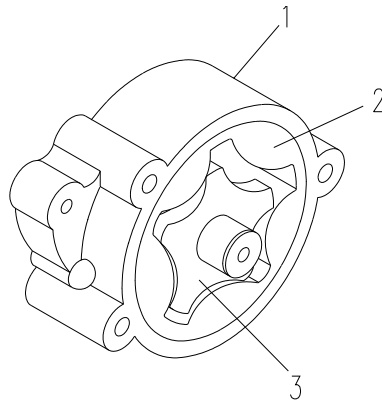

Figure 6-28. Oil Pump Assembly (Sheet 1 of 2)

REPLACE

- a. Remove three bolts (5) and remove oil pump assembly (1) and gasket (4).
- b. Install oil pump assembly (1) and gasket (4) and secure with three bolts (5).

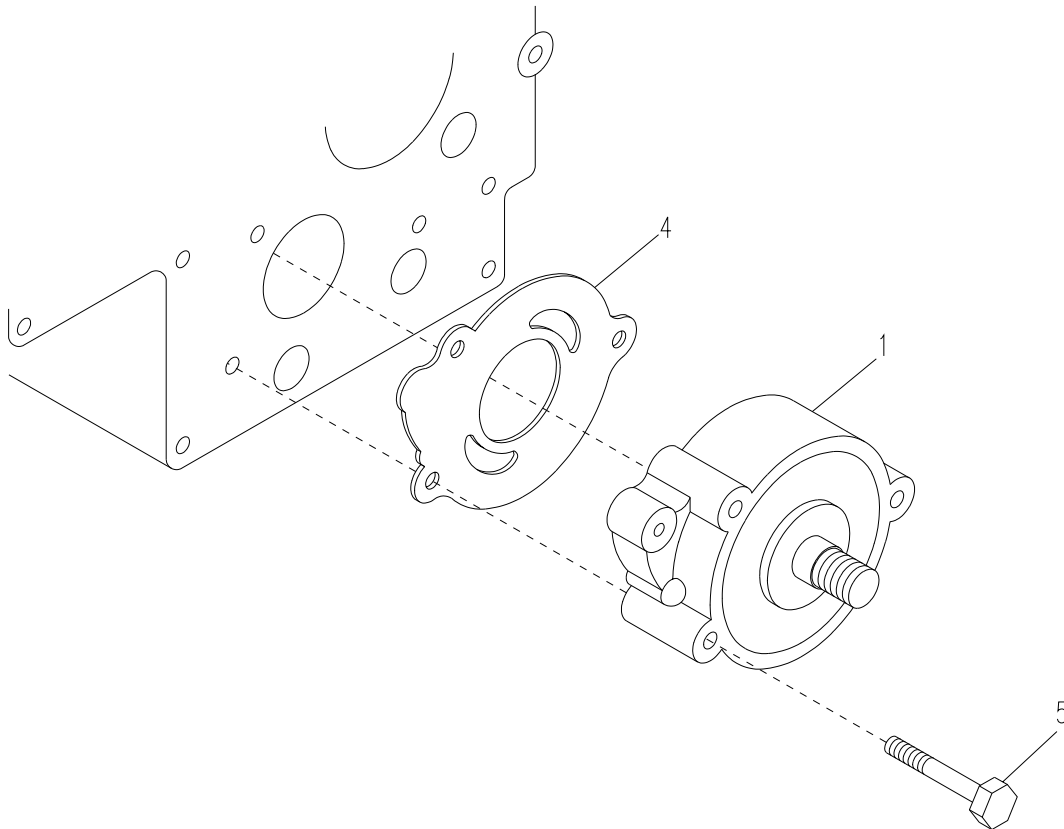

Figure 6-28. Oil Pump Assembly (Sheet 2 of 2)

6.32. RADIATOR SEAL FARING.

This task covers: Replace

INITIAL SETUP

Tools

General Mechanic's Tool Kit
(Item 1, Appendix B)

Shop Equipment, Electrical Repair,
Semitrailer Mounted
(Item 3, Appendix B)

Riveter
(Item 31, Appendix B)

Materials/Parts

Radiator Seal Faring

Rivets
(Item 15, Appendix F)

Equipment Conditions

Engine shutdown and allowed to cool for ten minutes.

REPLACE

- a. Set up a drill with a 3/16-in. bit dia. Drill out the heads of 14 rivets (4, Figure 6-29).
- b. Remove rivets (4). Use a punch if necessary.

NOTE

There is a difference between SICPS, JTACS and WIN-T faring width.

- c. Remove four bolts and washers (3), nuts with captive washers (5), and pull handle (2) and faring (1).

NOTE

Do not install rivets in bolt holes for pull handle.

- d. Install faring (1) and pull handle (2) and secure with four bolts and washers (3) and nuts with captive washers (5).
- e. Use riveter to secure faring (1) with 14 rivets (4).

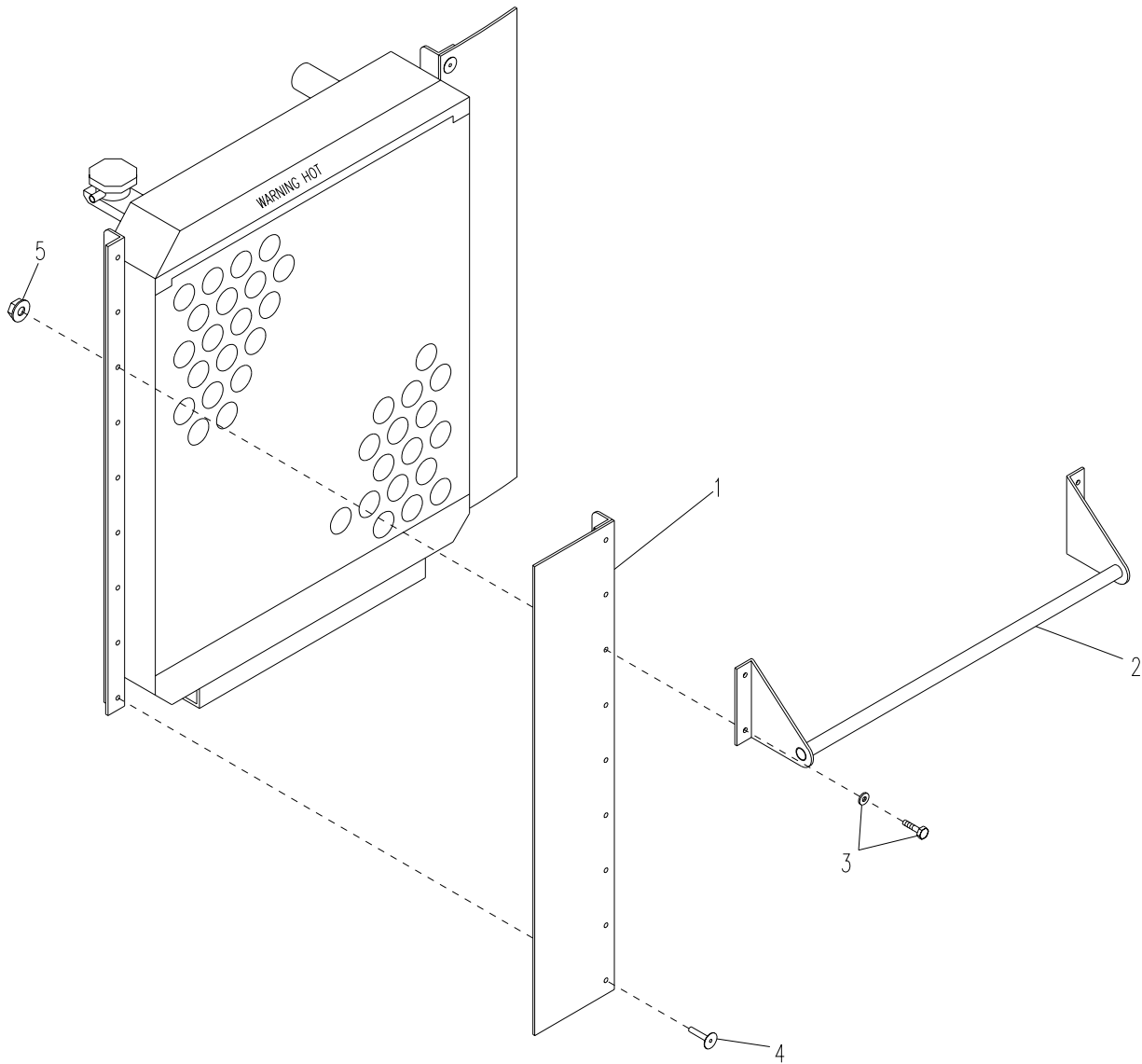

Figure 6-29. Radiator Seal Faring

6.33. WATER FLANGE.

This task covers: Replace

INITIAL SETUP

Tools

General Mechanic's Tool Kit
(Item 1, Appendix B)

Equipment Conditions

Gear box case and/or cylinder head removed.

Materials/Parts

Water Flange
Water Flange Gasket

Sealing Compound 88205952
(Item 18, Appendix F)

REPLACE

NOTE

Hardware securing temperature sender block is removed when thermostat is removed in initial SET-UP.

- a. Remove the temperature sender block (1, Figure 6-30).
- b. Remove two bolts and lockwashers (8) and alternator bracket (7) from water flange.
- c. Remove three screws (5 and 6) securing water flange (2) to engine block (4).
- d. Remove water flange (2) and water flange gasket (3).
- e. Apply sealing compound to both sides of new water flange gasket (3).
- f. Install new water flange gasket (3) and new water flange (2) to engine block (4) and secure with three screws (5 and 6).
- g. Install temperature sender mount block (1).

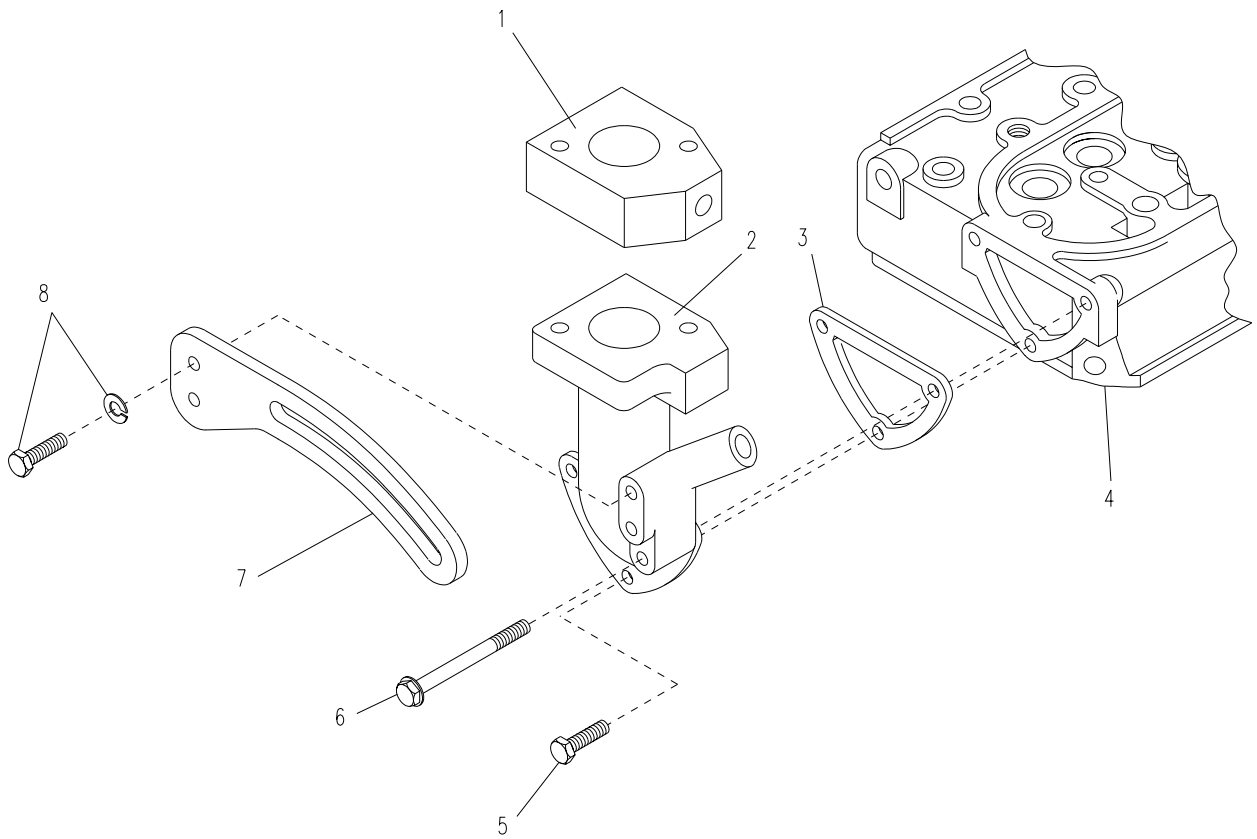

Figure 6-30. Water Flange

6.34. EXCITER STATOR.

This task covers: Replace

INITIAL SETUP

Tools

General Mechanic's Tool Kit
(Item 1, Appendix B)

Shop Equipment, Electrical Repair,
Semitrailer Mounted
(Item 3, Appendix A)

Materials/Parts

Exciter Stator

Strap, Tiedown Elect
(Item 22, Appendix F)

Equipment Conditions

MASTER ON/OFF switch on APU control unit set to OFF.

WARNING

Ensure that the APU is off and completely deenergized before working on generator. Failure to heed this warning could result in severe injury or DEATH by electrocution.

REPLACE

- a. Remove four screws (JTACS) or slotted hex-head bolts (SICPS and WIN-T), flat and lock washers (2, Figure 6-31) and remove generator housing top cover (1).
- b. Remove two screws, wing nuts and lock washers (4a) (JTACS) or four slotted hex-head bolts (SICPS and WIN-T), flat and lock washers (4), and generator housing side cover (3) (muffler side).
- c. Remove four screws and flat washers (5) securing louvered cover (6) to generator.
- d. Remove six bolts, lock washers, and flat washers (7) securing bearing housing (8) to generator.
- e. Use a two-jaw puller to remove bearing housing (8) from generator.

CAUTION

If bearing comes loose when removing bearing housing, use a rubber mallet to tap bearing in.

- f. Tag and remove leads from AVR terminals X and XX (9).

CAUTION

Do not cut wires when removing tiedown straps.

CAUTION

If necessary, cut tiedown straps to remove two electrical wires between AVR terminals X and XX and excitor stator.

- g. Remove four bolts and lock washers (10) and exciter stator (11) from bearing housing (12).
- h. Install exciter stator (11) in bearing housing (12) and secure with four bolts and lock washers (10).
- i. Connect two leads from exciter stator to AVR terminals X and XX (9).
- j. Install bearing housing (8) and secure with six bolts, lock washers, and flat washers (7).
- k. Install generator housing side cover (3) and secure with two screws, wing nuts and lock washers (4a) (JTACS), or four slotted hex-head bolts (SICPS and WIN-T), and flat and lock washers (4).
- l. Install generator housing top cover (1) and secure with four screws (JTACS) or slotted hex-head bolts (SICPS and WIN-T), flat and lock washers (2).
- m. Install louvered cover (6) and secure with four bolts and flat washers (5).

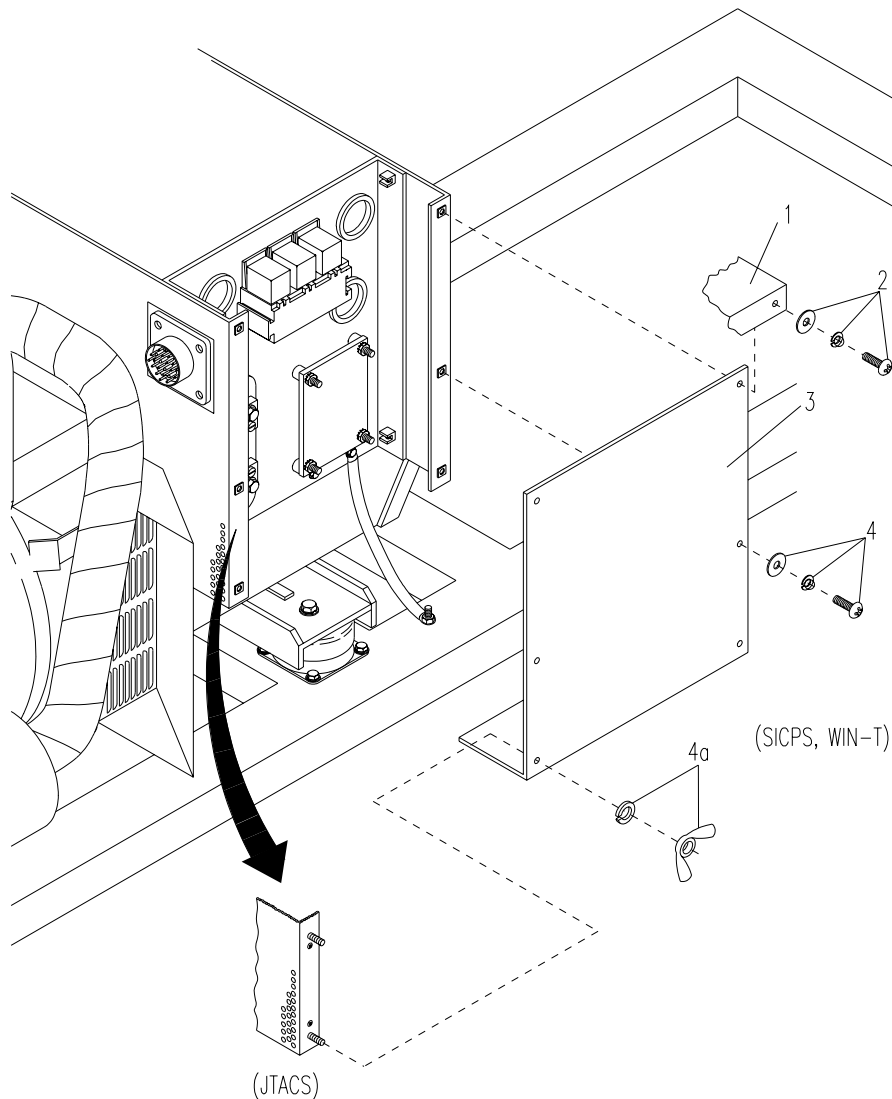

Figure 6-31. Exciter Stator (Sheet 1 of 4)

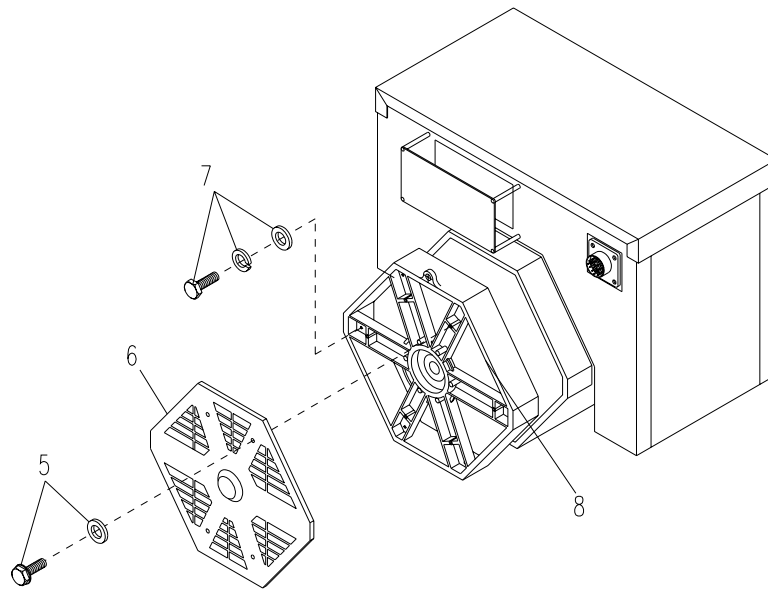

Figure 6-31. Exciter Stator (Sheet 2 of 4)

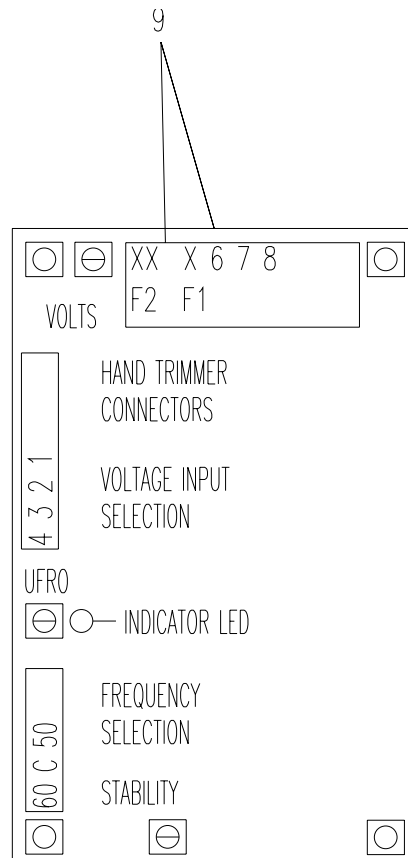

Figure 6-31. Exciter Stator (Sheet 3 of 4)

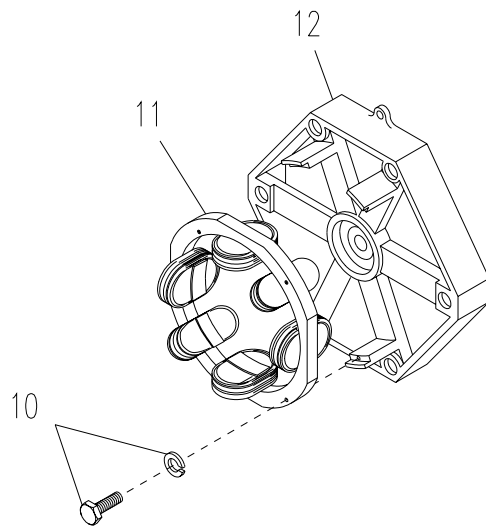

Figure 6-31. Exciter Stator (Sheet 4 of 4)

6.35. MAIN RECTIFIER ASSEMBLY.

This task covers: a. Inspect b. Test c. Repair

INITIAL SETUP

Tools

Shop Equipment, Electrical Repair,
Semitrailer Mounted
(Item 3, Appendix B)

Equipment Conditions

Exciter stator removed (para 6.34.).

WARNING

Materials/Parts

Main Rectifier Assembly Diodes
Varistor

Ensure that the APU is off and completely deenergized before working on generator. Failure to heed this warning could result in severe injury or DEATH by electrocution.

INSPECT

Inspect varistor (1, Figure 6-32) and replace (REPAIR, steps e - f) if showing signs of deterioration.

TEST

- a. Tag and unsolder leads (3) from diodes (2).
- b. Loosen nut (4) and remove diodes (2) from rectifier assembly (5).
- c. Use diode checker on an ohmmeter to test diodes. Replace bad diodes (REPAIR, steps a - d).

REPAIR

- a. Tag and unsolder leads (3) from diodes (2).
- b. Loosen nut (4) and diodes (2) from rectifier assembly.

CAUTION

When replacing, observe the polarity of the diodes. Place positive diodes in positive position and negative diodes in negative position.

- c. Install diode (2) and secure with nut (4).
- d. Solder lead (3) to diode (2). Remove tag.
- e. Remove two bolts, lock washers (6), and remove varistor (1).
- f. Install varistor and secure with two bolts and lock washers (6).

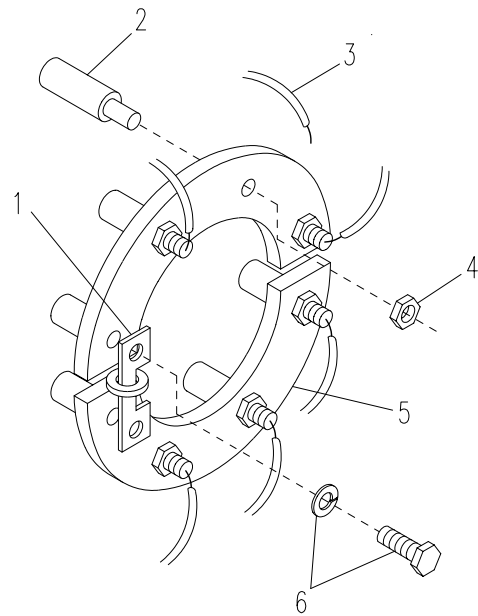

Figure 6-32. Main Rectifier Assembly

6.36. GENERATOR BEARING.

This task covers: a. Inspect b. Replace

INITIAL SETUP

Tools

Shop Equipment, Electrical Repair,
Semitrailer Mounted
(Item 3, Appendix B)

Equipment Conditions

Exciter stator removed (para 6.34.).

WARNING

Materials/Parts

Generator Bearing

Ensure that the APU is off and completely deenergized before working on generator. Failure to heed this warning could result in severe injury or DEATH by electrocution.

Bearing Grease
(Item 23, Appendix F)

INSPECT

Inspect bearing for signs of wear or loss of grease.

REPLACE

- a. Use a two pronged puller to carefully remove bearing (1, Figure 6-33) from shaft (2).
- b. Apply grease to shaft (2).
- c. Install bearing (1). Tap lightly with a rubber mallet if necessary. Wipe off excess grease.

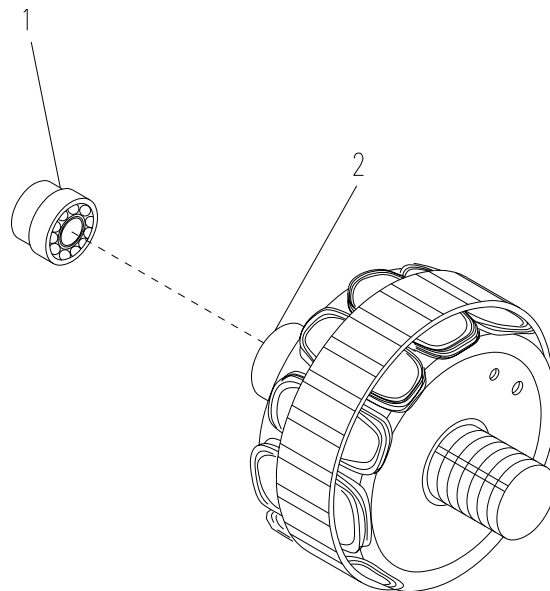

Figure 6-33. Generator Bearing

6.37. ROTOR.

This task covers: Replace

INITIAL SETUP

Tools

Shop Equipment, Electrical Repair,
Semitrailer Mounted
(Item 3, Appendix B)

Equipment Conditions

Generator assembly removed from APU (para
5.24.).

Materials/Parts

Rotor

REPLACE

- a. Remove four bolts and flat washers (9, Figure 6-34) securing louvered cover and removed cover (7).
- b. Remove six bolts and washers (5), pressure plate (4), and coupling hub (3) from rotor (1).
- c. Remove four bolts and lock washers (6) and remove generator fan (2).
- d. Secure lift sling to rotor (1) at drive end.
- e. At generator non drive end, tap on the rotor to loosen generator bearing (7) and rotor (1) free from bearing housing (10).

CAUTION

Ensure lifting sling fully supports rotor at all times.

- f. Continue to push rotor (1) through stator bore, gradually moving sling along rotor (1) as it is removed.
- g. Install rotor into stator bore and gradually move sling along rotor (1) as it is installed.
- h. At generator non drive end, install generator bearing (7) and rotor (1) into bear housing (10).
- i. Remove lift sling.
- j. Install generator fan (2) and secure with four bolts and lock washers (6).
- k. Install pressure plate (4) and coupling hub (3) and secure with six bolts and washers (5). Torque to 55 ft-lbs (74.8 Nm).
- l. Install louvered cover (7) and secure with four bolts and flat washers (9).

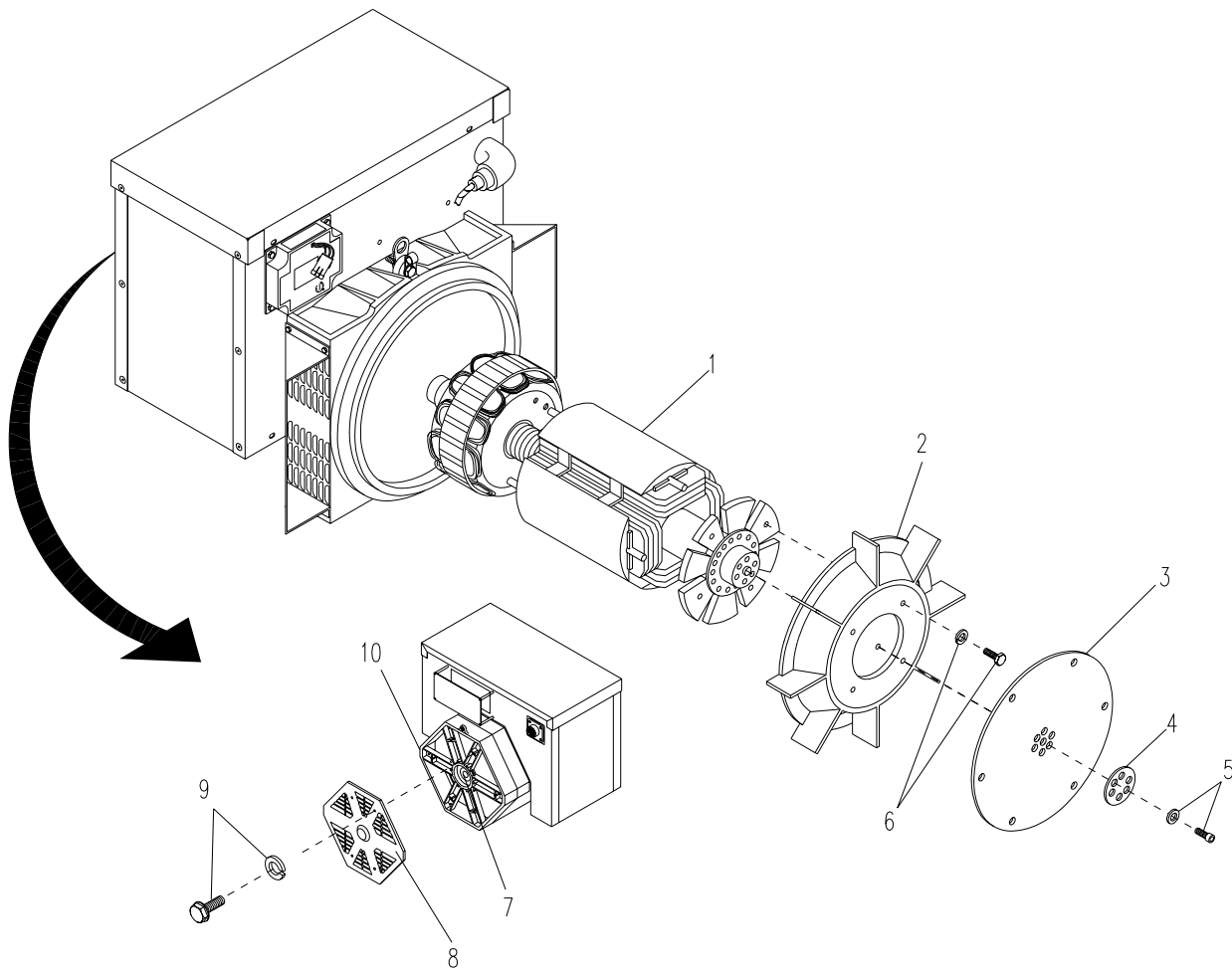

Figure 6-34. Rotor

APPENDIX A**REFERENCES****A-1. SCOPE.**

The following is a list of Army regulations, pamphlets, forms, service bulletins, technical bulletins, and technical manuals, and field manuals applicable to the APU.

A-2. PAMPHLETS.

DA PAM 25-30	Consolidated Index of Army Publications and Blank Forms
DA PAM 738-750	The Army Maintenance Management System (TAMMS)

A-3. FIELD MANUAL.

FM 21-11	First Aid for Soldiers
FM 3-3, FM 3-4, FM 3-5	Nuclear, Biological, and Decontamination Procedures
FM 20-31	Electric Power Generation in the Field
FM 9-207	Operation and Maintenance of Ordnance Material in Cold Weather (0°F to -65°F)

A-4. FORMS.

DA FORM 2028	Recommended Changes to Publications and Blank Forms
DA FORM 2028-2	Recommended Changes to Equipment Technical Publications
DA FORM 2404	Equipment Inspection and Maintenance Worksheet
SF-361	Transportation Discrepancy Report (TDR)
SF-364	Report of Discrepancy (ROD)
SF-368	Product Quality Deficiency Report
TO 00-35D-54	USAF Deficiency Reporting and Investigating System

A-5. TECHNICAL MANUALS.

TM 9-2320-280-10	Operator's Manual for: Truck, Utility: Heavy Variant, 4X4, M1097 (NSN 2320-01-346-9317)
TM 750-254	Cooling Systems: Tactical Vehicles
TM 750-244-3	Destruction of Army Equipment to Prevent Enemy Use

A-6. MISCELLANEOUS PUBLICATIONS.

MIL-HDBK-729	Corrosion and Corrosion Prevention: Metals
MIL-STD-129N	Marking for Shipment and Storage
TB 740-97-2	Preservation of USAMECOM Mechanical Equipment for Shipment and Storage
TM 43-0139	Painting Instruction for Army Materiel

THIS PAGE INTENTIONALLY LEFT BLANK

APPENDIX B

MAINTENANCE ALLOCATION CHART

Section I. INTRODUCTION

B-1. GENERAL.

- a. This section provides a general explanation of all maintenance and repair functions authorized at various maintenance categories.
- b. The Maintenance Allocation Chart (MAC) in Section II designates overall authority and responsibility for the performance of maintenance functions on Auxiliary Power Unit (APU). The application of maintenance functions to the generator sets or components will be consistent with the capacities and capabilities of the designated maintenance categories.
- c. Section III lists the tools and test equipment (both special tools and common tool sets) required for each maintenance function as referenced for Section II.
- d. Section IV contains supplemental instructions and explanatory notes for particular maintenance functions.

B-2. MAINTENANCE FUNCTIONS.

Maintenance functions will be limited to and defined as follows:

- a. **Inspect.** To determine the serviceability of an item by comparing its physical, mechanical and/or electrical characteristics with established standards through examination (e.g., by sight, sound, or feel).
- b. **Test.** To verify serviceability and to detect incipient failure by measuring the mechanical or electrical characteristics of an item and comparing those characteristics with prescribed standards.
- c. **Service.** Operations required periodically to keep an item in proper operating condition, i.e., to clean (decontaminate), to preserve, to drain, to paint, or to replenish fuel, lubricants, chemical fluids, or gases.
- d. **Adjust.** To maintain, within prescribed limits, by bringing into proper or exact position, or by setting the operating characteristics to specified parameters.
- e. **Align.** To adjust specified variable elements of an item to bring about optimum or desired performance.
- f. **Calibrate.** To determine and cause corrections to be made or to be adjusted on instruments or test, measuring and diagnostic equipment used in precision measurement. Consists of comparisons of two instruments, one of which is a certified standard of known accuracy, to detect and adjust any discrepancy in the accuracy of the instrument being compared.
- g. **Remove/Install.** To remove and install the same item when required to perform service or other maintenance functions. Install may be the act of emplacing, seating, or fixing into position a spare, repair part, or module (component or assembly) in a manner to allow the proper functioning of the equipment or system.

- h. Replace. To remove an unserviceable item and install a serviceable counterpart in its place.
- i. Repair. The application of maintenance services (inspect, test, service, adjust, align, calibrate, replace) or other maintenance actions (welding, grinding, riveting, straightening, facing, re-machining, or resurfacing) to restore serviceability to an item by correcting specific damage, fault, malfunction, or failure in a part, subassembly, module (component or assembly) end item, or system.
- j. Overhaul. That maintenance effort (service/action) necessary to restore an item to a completely serviceable/operational condition as prescribed by maintenance standards (i.e., DMWR) in appropriate technical publications. Overhaul is normally the highest degree of maintenance performed by the Army. Overhaul does not normally return an item to like-new condition.
- k. Rebuild. Consists of those services/actions necessary for the restoration of unserviceable equipment to a like-new condition in accordance with original manufacturing standards. Rebuild is the highest degree of material maintenance applied to Army equipment. The rebuild operation includes the act of returning to zero those age measurements (hours, miles, etc.) considered in classifying Army equipment/components.

B-3. EXPLANATION OF COLUMNS IN THE MAC, SECTION II.

- a. Column 1, Group Number. Column 1 lists functional group code numbers, the purpose of which is to identify components, assemblies, subassemblies, and modules within the next higher assembly.
- b. Column 2, Component/Assembly. Column 2 contains the names of components, assemblies, subassemblies, and modules for which maintenance is authorized.
- c. Column 3, Maintenance Function. Column 3 lists the functions to be performed on the item listed in column 2.
- d. Column 4, Maintenance Level. Column 4 specifies, by the listing of a work time figure in the appropriate subcolumn(s), the lowest level of maintenance authorized to perform the functions listed in column 3. This figure represents the active time required to perform that maintenance function at the indicated level of maintenance. If the number or complexity of tasks within the listed maintenance function vary at different maintenance levels, appropriate work time figures will be shown for each level. The work time figure represents the average time required to restore an item (assembly, subassembly, component, module, end item or system) to a serviceable condition under typical field operating conditions. This time includes preparation time, including necessary disassembly/assembly time, troubleshooting/fault location time, and quality assurance/quality control time in addition to the time required to perform the specific tasks identified for the maintenance function authorized in the Maintenance Allocation Chart (MAC). The symbol designations for the various maintenance levels are as follows:

- C Operator/Crew (Unit Level Maintenance)
- O Organizational (Unit Level Maintenance)
- F Direct Support
- H General Support
- D Depot

- e. Column 5, Tools and Equipment. Column 5 specifies by code, those common tool sets (not individual tools) and special tools, TMDE, and support equipment required to perform the designated function.

TM 9-6115-670-14&P

f. Column 6, Remarks. Column 6 identifies remarks defined in section IV of the MAC.

B-4. EXPLANATION OF COLUMNS IN TOOL AND TEST EQUIPMENT REQUIREMENTS, SECTION III.

- a. Column 1, Reference Code. The tool and test equipment reference code correlates with a code used in the MAC, Section II, Column 5.
- b. Column 2, Maintenance Level. The lowest level of maintenance authorized to use the tool or test equipment.
- c. Column 3, Nomenclature. Name or identification of the tool or test equipment.
- d. Column 4, National/NATO Stock Number. The National Stock Number of the tool or test equipment.
- e. Column 5, Tool Number. The manufacturer's part number, model number, or type number.

B-5. EXPLANATION OF COLUMNS IN REMARKS, SECTION IV.

- a. Column 1, Reference Code. The code recorded in Column 6, Section II.
- b. Column 2, Remarks. This column, along with the related codes, should be used to clarify maintenance and inspection functions by different MOS' involved in maintaining some components.

**MAINTENANCE ALLOCATION CHART
FOR
AUXILIARY POWER UNIT, 10kW, 120/240 VAC, 60Hz, MEP-903A, MEP-903B AND MEP-903C**

(1) GROUP NUMBER	(2) COMPONENT ASSEMBLY	(3) MAINTENANCE FUNCTION	(4) MAINTENANCE LEVEL					(5) TOOLS AND EQUIPMENT	(6) REMARKS
			UNIT		DIRECT SUPPORT	GENERAL SUPPORT	DEPOT		
			C	O	F	H	D		
00	AUXILIARY POWER UNIT, 10 KW, 120/240v, 60 HZ								
01	GENERATOR 10 KW, APU	Inspect	0.5	0.5				A	
0101	FRAME ASSEMBLY, SICPS	Inspect			0.1			AC	
		Repair			0.5		1,52	Z,AM	
		Replace			2.0		1,52	AM	
0102	FRAME ASSEMBLY, JTACS/ WIN-T	Inspect			0.1			AC	
		Repair			1.0		1,52	Z,AM	
		Replace			2.5		1,52	AM	
0103	FUEL DAY TANK ASSEMBLY, SICPS	Service		0.5			1,22		
		Test		0.5			1,3,22		
		Repair		1.0			1	H	
		Replace		1.0			1		
0104	FUEL DAY TANK ASSEMBLY, JTACS/WIN-T	Service		0.5			1,22		
		Test		0.5			1,3,22		
		Repair		1.0			1	H	
		Replace		1.0			1		
0105	ENGINE ASSEMBLY	Inspect	0.2	0.2				A	
010501	ENGINE; DIESEL, TURBO, 3 CYLINDER, LIQUID COOLED	Test			2.5	2.5	1,3,5,11,12,39, 42,43,47,48	Y,AA	
		Replace			2.0		1,3,52	AM	
		Repair			12	12	1,2,4-6,8-10, 14-18,32,33,38, 45,49,52	V,N,AM	
01050101	LUBRICATING SYSTEM	Inspect	0.1					C	
		Service	0.1	0.5			1	A	
		Test			0.5	1.2	1,3	AI,AJ	
		Repair		0.5	1.0	1.2	1	B,W,AG	
01050102	COOLING SYSTEM	Inspect	0.1					Q	
		Test		1.0			1,3,21	A	
		Adjust		0.5			1, 50, 51	R	
		Repair		0.5	0.5	2.3	1, 50, 51	D,E,AL	
01050103	ELECTRICAL SYSTEM	Test		0.5			3,20		
		Service		0.5			1	K	
		Repair		0.8			1	J	

**MAINTENANCE ALLOCATION CHART
FOR
AUXILIARY POWER UNIT, 10kW, 120/240 VAC, 60Hz, MEP-903A, MEP-903B AND MEP-903C
(Continued)**

(1) GROUP NUMBER	(2) COMPONENT ASSEMBLY	(3) MAINTENANCE FUNCTION	(4) MAINTENANCE LEVEL					(5) TOOLS AND EQUIPMENT	(6) REMARKS
			UNIT		DIRECT SUPPORT	GENERAL SUPPORT	DEPOT		
			C	O	F	H	D		
01050104	FUEL SYSTEM	Service	0.3	0.3				1	A,AF
		Test			0.5			1,19,22,29,30	A
		Adjust			0.5			1	I
		Repair		0.8	1.5			1	G,F
0105010401	INJECTOR PUMP	Adjust				4.5		1	
		Repair			0.5			1	AB
		Replace			0.5			1	
		Inspect	0.2						
0105010402	FUEL FILTER ASSEMBLY	Service		0.3				1	A
		Repair		0.5				1	Z
		Replace		0.5				1	
		Test				1.0		1,44	
01050105	CYLINDER HEAD	Repair				1.5		3,37	
		Replace				2.0		1,2	
		Test				1.0		1,14,42,43	
01050106	CONNECTING ROD	Repair				1.0		1,17	
		Replace				1.0		1	
		Test		0.2				3	
0106	FUEL PUMP ASSEMBLY	Repair		0.3				3	P
		Replace		0.3				1	
		Inspect	0.3						
0107	RADIATOR SUBASSEMBLY	Service	0.3	0.2				1	A
		Test		0.5	0.2			7	A
		Repair		1.0	1.0	0.5		1,31	AH
		Replace		2.0	2.0			1	
		Test		0.3					
0108	SPEED SENSOR ASSEMBLY	Adjust		0.3				1	
		Replace		0.5				3	
		Inspect			0.1			1	Q
0109	WIRING HARNESS, J3, DC BOX, APU	Test			0.2			1,3	X
		Repair			1.0			1,3	
		Replace			0.5			1,3,28	
		Inspect							
0110	WIRING HARNESS, ENGINE, P1	Test		0.1	1.0			1,3	X
		Repair			0.2			1,3	
		Replace			0.5			1,3,28	

**MAINTENANCE ALLOCATION CHART
FOR
AUXILIARY POWER UNIT, 10kW, 120/240 VAC, 60Hz, MEP-903A, MEP-903B AND MEP-903C
(Continued)**

(1) GROUP NUMBER	(2) COMPONENT ASSEMBLY	(3) MAINTENANCE FUNCTION	(4) MAINTENANCE LEVEL					(5) TOOLS AND EQUIPMENT	(6) REMARKS
			UNIT		DIRECT SUPPORT	GENERAL SUPPORT	DEPOT		
			C	O	F	H	D		
0111	WIRING HARNESS, J1	Inspect			0.1				Q
		Test			1.0			1,3	X
		Repair			0.2			1,3	
		Replace			0.5			1,3,28	
0112	GOVERNOR CONTROL ASSEMBLY	Repair		0.5				1,3	O
		Replace		0.5				1,3	
0113	GENERATOR, 10 KW, 60HZ	Inspect	0.2	0.1					
		Test		2.0	2.0	1.0		1,3,4,23-27	M
		Repair			1.5	0.5		1,52	T,S,AM
		Replace		2.0	2.0			1,52	AM
011301	MAIN RECTIFIER ASSEMBLY	Inspect				1.0		1,3	AE
		Test				0.8		1,3	X
		Repair				0.8		1,3	AD
		Replace				2.0		1,3	
02	WIRING HARNESS, CONTROL CABLE	Inspect	0.1						Q
		Test			1.0			1,3	X
		Repair			0.2			1,3	
		Replace			1.0			1,3,28,33	
03	CONTROL BOX ASSEMBLY	Inspect	0.1						
		Test		0.2	0.2			1,3	X
		Repair			1.0			1,3,33	U,AK
		Replace		0.8	0.8			1,3	
0301	WIRING HARNESS J2	Inspect			0.1				Q
		Test			1.0			1,3	X
		Repair			0.5			1,3	
		Replace			0.5			1,3,28,33	

**Section III.
TOOLS AND TEST EQUIPMENT REQUIREMENTS FOR AUXILIARY POWER UNIT,
10 kW, 120/240 VAC, 60 Hz, MEP-903A, MEP-903B AND MEP-903C**

TOOL OR TEST EQUIPMENT REF CODE	MAINTENANCE CATEGORY	NOMENCLATURE	NATIONAL/NATO STOCK NUMBER	TOOL NUMBER
1	O,C,F,H	TOOL KIT, GENERAL MECHANIC'S	5180-00-177-7033	SC5180-95-N26
2	FH	SHOP EQUIPMENT, ELECTRICAL REPAIR, SEMITRAILER MOUNTED	4940-00-294-9517	SC4940-95-B05
3	O	SHOP EQUIPMENT, AUTOMOTIVE MAINTENANCE AND REPAIR: ORG COMMON NO.1	4910-00-754-0654	SC4910-95-A74
4	F	SHOP EQUIPMENT, AUTOMOTIVE MAINTENANCE AND REPAIR: FIELD MAINTENANCE, BASIC, LESS POWER	4910-00-754-0705	SC4910-95-A31
5	O,F,H	WRENCH, TORQUE	5120-00-242-3264	B107.14M
6	F	PULLER SET, MECHANICAL		07916-32011
7	H	TESTER, LEAKGAE		KTST 10080
8	H	TOOL KIT, VALVE SEAT		07909-33102
9	H	PULLER, MECHANICAL	5120-01-486-5065	07916-09032
10	H	RETAINER, SLEEVE SETTER		07916-34041
11	H	TESTER, CYLINDER, COMPRESSION		KTST 10060-G
12	H	ADAPTER, CYLINDER, COMPRESSION		KTST 10060-E
13	F	GAUGE, PRESSURE, DIAL	6685-01-486-0361	07916-32032
14	H	ALIGNING TOOL, ROTATION	5120-01-479-5832	07909-31661
15	H	VALVE GUIDE REPLACING TOOL		APUMT1
16	H	CRANKSHAFT BEARING 1 REPLACING TOOL		APUMT2
17	H	CONNECTING ROD SMALL END BUSHING TOOL		APUMT3
18	H	IDLE GEAR BUSHING REPLACING TOOL		APUMT4
19	F,H	INJECTION PUMP PRESSURE TESTER		APUMT5
20	F	BATTERY, 24 VOLT DC	6140-00-484-1528	MP405
21	O	THERMOMETER	6685-00-051-4845	52S0TC
22	F	HAND SIPHON	4320-01-226-3773	9894K32
23	F	TRANSFORMER, 240 VAC ISOLATING	5950-00-921-4908	
24	F	TRANSFORMER, POWER, AUTOTRANSFORMER	5950-00-921-4908	VTI0H
25	F	5 AMP FUSE	5920-01-019-0879	F283-5AMP
26	F	2 AMP FUSE	5920-00-284-9494	L00475
27	F	NEON LAMP	5120-01-085-0685	193477-1
28	F	REMOVER, PIN	5120-01-361-3067	910112104
29	F	TESTER, DIESEL FUEL		KTST 20010
30	F	NOZZLE KIT TESTER		KTST 20020

Section III.
TOOLS AND TEST EQUIPMENT REQUIREMENTS FOR AUXILIARY POWER UNIT,
10 kW, 120/240 VAC, 60 Hz, MEP-903A, MEP-903B AND MEP-903C (Continued)

TOOL OR TEST EQUIPMENT REF CODE	MAINTENANCE CATEGORY	NOMENCLATURE	NATIONAL/NATO STOCK NUMBER	TOOL NUMBER
31	H	RIVETER	5120-01-377-1079	PRG-402HC
32	H	REAMER, HAND	5110-01-492-8462	KTST 10030A
33	F	HEATER, GUN TYPE, ELECTRIC	4940-00-028-7493	991609
34	O,F,H	GLOVES, CHEMICAL AND OIL PROTECTIVE	8415-01-235-0076	37-185TAILLE8-8 1/2
36	H	INDICATOR, DIAL	5210-00-540-6517	665JZ (DISC)
38	H	LIFTER, VALVE SPRING	5210-01-209-6870	J29834
39	H	GAGE, CYLINDER	5210-00-494-1774	A-A-52212
40	H	EXPANDER, PISTON RING	5120-00-857-3190	PRS8
41	H	COMPRESSOR, PISTON RING	5120-00-250-6055	RC40C
42	H	CALIPER, MICROMETER, INSIDE	5210-00-525-8159	7913326 (NO INFO)
43	H	ADAPTER, CABLE CLAMP TO CONNECTOR	5935-00-356-7895	731XFLZ-1
44	H	GAGE, DEPTH, MICROMETER	5210-00-058-0898	445B2-3RL
45	H	HONE,, CYLINDER	3460-01-048-5624	K16-J83
46	H	LOCK, FLYWHEEL	5120-01-333-1849	J36375
47	H	CALIPER, MICROMETER, INSIDE	5210-00-221-1919	599-263-1
48	H	CALIPER, MICROMETER, OUTSIDE	5210-01-356-7896	
49	H	BAR, BORING TOOL	3460-00-143-7996	801500
50	O	SOCKET, SOCKET WRENCH, 12.0 mm	5120-00-263-4137	MA-13
51	O	SOCKET, SOCKET WRENCH, 14.0 mm	5120-00-263-4136	MA-14

**Section IV. REMARKS FOR AUXILIARY POWER UNIT,
10 KW, 120/240 VAC, 60 HZ MEP-903A, MEP-903B AND MEP-903C**

REFERENCE CODE	REMARKS
A	PERFORM PREVENTIVE MAINTENANCE CHECKS AND SERVICES (PMCS).
B	UNIT LEVEL REPAIR LIMITED TO REPLACEMENT OF LINES, FITTINGS, RELIEF VALVE, OIL COOLER AND DIP STICK.
C	UNIT LEVEL INSPECTION LIMITED TO CHECKING OIL LEVEL.
D	UNIT LEVEL REPAIR LIMITED TO REPLACEMENT OF HOSES AND THERMOSTAT.
E	DIRECT SUPPORT REPAIR LIMITED TO REPLACEMENT OF WATER PUMP.
F	UNIT REPAIR LIMITED TO REPLACEMENT OF LINES, FITTINGS, FEEDER PUMP, FUEL FILTER, AND TRANSFER PUMP.
G	DIRECT SUPPORT REPAIR LIMITED TO REPLACEMENT OF INJECTION PUMP AND INJECTION NOZZLES.
H	REPAIR LIMITED TO REPLACEMENT OF LOW FUEL CUT-OFF SWITCH.
I	DIRECT SUPPORT ADJUSTMENT LIMITED TO REPLACEMENT OF ADJUSTING WASHER IN NOZZLE HOLDER ASSEMBLIES.
J	REPAIR LIMITED TO REPLACEMENT OF ALTERNATOR, TEMPERATURE SWITCH, TEMPERATURE SENDER, STARTER, AND LOW OIL PRESSURE SWITCH.
K	SERVICE BY REPLACING GLOW PLUGS.
L	REPAIR SPEED SENSOR BY REPLACING TERMINAL LUGS.
M	TEST AS PART OF TROUBLESHOOTING PROCEDURES.
N	REPLACE SEALING CAPS IF NECESSARY.
O	REPAIR GOVERNOR CONTROL ASSEMBLY BY REPLACING TERMINAL LUGS AND CONNECTORS.
P	REPAIR FUEL PUMP BY REPLACING TERMINAL LUGS AND CONNECTORS.
Q	INSPECT COMPONENTS FOR WEAR, FRAYING, CRACKS, SPLITS, SPLINTERING, ETC.
R	ADJUST FAN BELT.
S	DIRECT SUPPORT LEVEL REPAIR LIMITED TO REPLACEMENT OF RELAY BOARD, AUTOMATIC VOLTAGE REGULATOR, OVERLOAD RELAY, AND 24 VDC CONTACTOR.
T	GENERAL SUPPORT REPAIR LIMITED TO REPLACEMENT OF EXCITER STATOR AND ROTOR.
U	REPAIR LIMITED TO REPLACEMENT OF METERS, GAUGES, SWITCHES, AND LAMPS.
V	GENERAL SUPPORT REPAIR INCLUDES TESTING AND REPLACEMENT OF PISTONS, CRANKSHAFT, CAMSHAFT, GEARS, ROCKER ARM ASSEMBLY COMPONENTS, AND VALVES.
W	GENERAL SUPPORT LEVEL REPAIR INCLUDES REPLACEMENT OF OIL PUMP.
X	PERFORM CONTINUITY CHECKS.
Y	TEST ENGINE COMPRESSION PRESSURE.
Z	REPAIR BY REPLACEMENT OR REPAIR OF COMPONENTS.
AA	GENERAL SUPPORT LEVEL TEST INCLUDES TESTING OF PISTONS, CRANKSHAFT, CAMSHAFT, FUEL CAMSHAFT, AND GEARS.
AB	REPAIR BY REPLACING GASKETS.
AC	VISUAL AND MECHANICAL INSPECTION OF UNIT/ASSY FOR DAMAGE, CRACKS, CORROSION, LOOSE OR MISSING HARDWARE, ETC.
AD	REPAIR BY REPLACING DIODES.
AE	INSPECT VARISTOR FOR DETERIORATION.
AF	UNIT LEVEL SERVICE INCLUDES BLEEDING FUEL SYSTEM.
AG	DIRECT SUPPORT REPAIR LIMITED TO REPLACEMENT OF OIL PAN, OIL PAN COVER AND OIL STRAINER.

**Section IV. REMARKS FOR AUXILIARY POWER UNIT,
10 KW, 120/240 VAC, 60 HZ MEP-903A, MEP-903B AND MEP-903C (Continued)**

REFERENCE CODE	REMARKS
AH	GENERAL SUPPORT REPAIR LIMITED TO REPLACEMENT OF FARINGS.
AI	DIRECT SUPPORT TEST LIMITED TO CHECKING OIL PRESSURE.
AJ	GENERAL SUPPORT TEST INCLUDES CLEARANCE CHECKS ON OIL PUMP.
AK	REPAIR INDICATOR LIGHT ASSEMBLY BY REPLACING TERMINAL LUGS.
AL	GENERAL SUPPORT REPAIR INCLUDES REPLACEMENT OF WATER FLANGE.
AM	LIFTING DEVICE REQUIRED FOR MAINTENANCE.

APPENDIX C

Operator, Unit, Direct Support and General Support Maintenance Repair Parts and Special Tools List for AUXILIARY POWER UNIT, 10 KW, 120/240 VAC, 60 HZ

Section I. Introduction

C-1. Scope

This manual lists and authorizes spares and repair parts; special tools; special test, measurement, and diagnostic equipment (TMDE); and other special support equipment required for the performance of Operator, Unit, Direct Support and General Support Maintenance of the Auxiliary Power Unit, 10KW, 120/240 VAC, 60Hz. It authorizes the requisitioning, issue, and disposition of spares, repair parts and special tools as indicated by the source, maintenance, and recoverability (SMR) codes.

C-2. General

In addition to Section I, Introduction, this Repair Parts and Special Tools List (RPSTL) is divided into the following sections:

a. Section II. Repair Parts List. A list of spares and repair parts authorized by this RPSTL for use in the performance of maintenance. This list also includes parts, which must be removed for replacement of the authorized parts. Parts lists are composed of functional groups in ascending numeric sequence, with the parts in each group listed in ascending item number sequence. Figure numbers are listed directly beneath the group header. Bulk materials are listed in item name sequence. Items listed are shown on the associated illustration.

b. Section III. Special Tools List. A list of special tools, special TMDE and other special support equipment authorized by this RPSTL (as indicated by Basis of Issue (BOI) information in DESCRIPTION AND USABLE ON CODE (UOC) column) for the performance of maintenance.

c. Section IV. Cross-Reference Indexes. A list, in National Item Identification Number (NIIN) sequence, of all National stock numbered items appearing in the listings, followed by a list in alphanumeric sequence of all part numbers appearing in the listing. National Stock Numbers (NSNs) and part numbers are crossed referenced to each illustration figure and item number appearance.

C-3. Explanation of Columns (Sections II and III)

a. ITEM NO. (Column (1)). Indicated the number used to identify items called out in the illustration.

b. SMR Code (Column (2)). The Source, Maintenance, and Recoverability (SMR) code is a five-position code containing supply/requisitioning information, maintenance category authorization criteria, and disposition instructions, as shown in the following breakout:

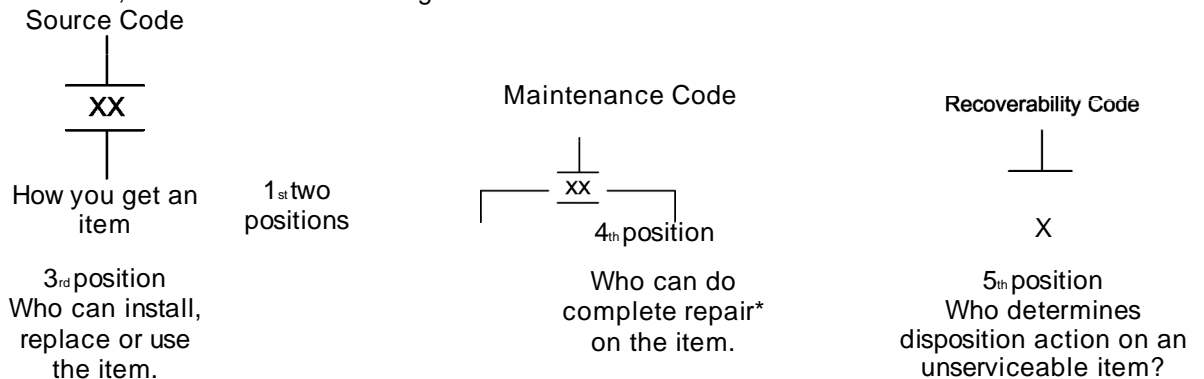

ARMY TM 9-6115-670-14&P

*Complete repair: Maintenance capacity, capability, and authority to perform all corrective maintenance tasks of the "repair" function is a use/user environment in order to restore serviceability to a failed item.

(1) *Source code*. The source code tells you how to get an item needed for maintenance, repair, or overhaul of an end item/equipment. Explanations of source codes follows:

Code	<u>Explanation</u>
PA PB PC** PD PE PF PG	Stocked items: use the applicable NSN to request/requisition items with these source codes. They are authorized to the category indicated by the code entered in the third position of the SMR code. **NOTE: Items coded PC are subject to deterioration.
KD KF KB	Items with these codes are not be requested/requisitioned individually. They are part of a kit which is authorized to the maintenance category indicated in the third position of the SMR code. The complete kit must be requisitioned and applied.
MO – Made at org/AVUM Level MF – Made at DS/AVIM Level MH – Made at GS Level ML – Made at Specialized Repair Activity (SRA) MD – Made at Depot	Items with these codes are not to be requested/requisitioned individually. They must be made from bulk material which is identified by the part number in the DESCRIPTION AND USABLE ON CODE (UOC) column and listed in the Bulk Material group of the repair parts list in this RPSTL. If the item is authorized to you by the third position code of the SMR code, but the source code indicates it is made at a higher level, order the item from the higher level of maintenance.
AO – Assembled by Unit/AVIIM Level AF – Assembled by DS/AVIM Level AH – Assembled by GS Level AL – Assembled by SRA AD – Assembled by Depot	Items with these codes are not to be requested/requisitioned individually. The parts that make up the assembled item must be requisitioned or fabricated and assembled at the level of maintenance indicated by the source code. If the third position code of the SMR code authorizes you to replace the item, but the source code indicates the item is assembled at a higher level of maintenance, order the item from the higher level of maintenance.

Code**Explanation**

XA - Do not requisition an "XA" coded item. Order its next higher assembly. (Refer to NOTE below.) XB - If an "XB" item is not available from salvage, order it using the CAGEC and part number given. XC - Installation drawing, diagram, instruction sheet, field service drawing, that is identified by manufacturer's part number.

XD - Item is not stocked. Order an "XD" coded item through normal supply channels using the CAGEC and part number given if no NSN is available.

NOTE

Cannibalization or controlled exchange, when authorized, may be used as a source of supply for the items with the above source codes, except for those source coded "XA" or those aircraft support items restricted by requirements of AR 750-1.

(2) *Maintenance code.* Maintenance codes tell you the level of maintenance authorized to USE and REPAIR support items. The maintenance codes are entered in the third and fourth positions of the SMR Code as follows:

(a) *Maintenance Code Third Position.* The maintenance code entered in the third position tells you the lowest maintenance level authorized to remove, replace, and use an item. The maintenance code entered in the third position will indicate authorization to one of the following levels of maintenance.

Code**Application/Explanation**

- C - Crew or operator maintenance done within organizational or aviation maintenance.
- - Organizational or aviation unit level can remove, replace, and use the item.
- F - Direct support or aviation intermediate level can remove, replace, and use the item.
- - General support level can remove, replace, and use the item.
- L - Specialized repair activity can remove, replace, and use the item.
- - Depot level can remove, replace, and use the item.

(b) *Maintenance Code Fourth Position.* The maintenance code entered in the fourth position tells whether or not the item is to be repaired and identifies the lowest maintenance level with the capability to do complete repair (i.e., perform all authorized repair functions). (NOTE: Some limited repair may be done on the item at a lower category of maintenance, if authorized by the Maintenance Allocation Chart (MAC) and SMR codes.) This position will contain one of the following maintenance codes:

Code**Application/Explanation**

- - Organizational or aviation unit is the lowest that can do complete repair of the item.
- F - Direct support or aviation intermediate is the lowest level that can do complete repair of the item.
- - General support is the lowest level that can do complete repair of the item.
- L - Specialized Repair Activity (designate the SRA) is the lowest level that can do complete repair of the item.
- - Depot is the lowest level that can do complete repair of the item.
- Z - Nonrepairable. No repair is authorized.
- B - No repair is authorized. (No parts or special tools are assigned for the maintenance of a "B" coded item.) However, the item may be reconditioned by adjusting, lubricating, etc., at the user level.

ARMY TM 9-6115-670-14&P

(3) *Recoverability code*. Recoverability codes are assigned to items to indicate the disposition action on unserviceable items. The recoverability code is entered in the fifth position of the SMR code as follows:

Recoverability Code

Application Explanation

Z - Nonreparable item. When unserviceable, condemn and dispose of the item at the level of maintenance shown in the third position of SMR code.

- - Repairable item. When uneconomically repairable, condemn and dispose of the item at unit or aviation unit level.

F - Repairable item. When uneconomically repairable, condemn and dispose of the item at direct support or aviation intermediate level.

- - Repairable item. When uneconomically repairable, condemn and dispose of the item at general support level.
- - Repairable item. When beyond lower level repair capability, return to depot. Condemnation and disposal of item not authorized below depot level.

L - Repairable item. Condemnation and disposal not authorized below specialized repair activity (SRA).

A - Item requires special handling or condemnation procedures because of specific reasons (e.g., precious metal content, high dollar value, critical material, or hazardous material). Refer to appropriate manuals/directives for specific instructions.

c. *CAGEC (Column (3))*. The Commercial and Government Entity Code (CAGEC) is a 5-digit numeric code which is used to identify the manufacturer, distributor, or Government agency, etc., that supplies the item.

d. *PART NUMBER (Column (4))*. Indicates the primary number used by the manufacturer (individual company, firm, corporation, or Government activity), which controls the design and characteristics of the item by means of its engineering drawings, specifications, standards, and inspection requirements to identify an item or range of items.

NOTE

When you use an NSN to requisition an item, the item you receive may have a different part number from the part ordered.

e. *DESCRIPTION AND USABLE ON CODE (UOC) (Column (5))*. This column includes the following information:

(1) The Federal item name and, when required, a minimum description to identify the item.

(2) Part numbers for bulk materials are referenced in this column in the line entry for the item to be manufactured/fabricated.

The usable on code, when applicable (see paragraph 5, Special Information)

(3)

(4) In the Special Tools List section, the basis of issue (BOI) appears as the last line in the entry for each special tool, special TMDE, and other special support equipment. When density of equipments supported exceeds density spread indicated in the basis of issue, the total authorization is increased proportionately.

The statement "End of Figure" appears just below the last item description in Column (5) for a given figure in Section II and Section III.

(5)

f. *Qty (Column (6))*. Indicates the quantity of the item used in the breakout shown on the illustration figure, which is prepared for a functional group, subfunctional group, or an assembly. A "V" appearing in this column in lieu of a quantity indicates the quantity is variable and may vary from application to application.

C-4. EXPLANATION OF COLUMNS (Section IV). a.

NATIONAL STOCK NUMBER (NSN) INDEX.

(1) *STOCK NUMBER Column.* This column lists the NSN by National item identification number (NIIN) sequence. The NIIN consists of the last nine digits of the NSN. When using this column to locate an item, ignore the first four digits of the NSN. When requisitioning items, use the complete NSN (13 digits).

(2) *FIG. Column.* This column lists the number of the figure where the item is identified/located. The figures are in numerical sequence in Section II and Section III.

(3) *ITEM Column.* The item number identifies the item associated with the figure listed in the adjacent FIG. column. This item is also identified by the NSN listed on the same line.

b. PART NUMBER INDEX. Part numbers in this index are listed by part number in ascending alpha numeric sequence.

(1) *CAGEC Column.* This column lists the CAGEC.

(2) *PART NUMBER Column.* This column indicates the part number assigned to the item.

(3) *STOCK NUMBER Column.* This column lists the NSN for the associated part number and manufacturer identified in the part number and CAGEC columns to the left.

(4) *FIG. Column.* This column lists the number of the figure where the item is identified/located in sections II and III.

(5) *ITEM Column.* The item number is that number assigned to the item as it appears in the figure referenced in the adjacent figure number column.

c. FIGURE AND ITEM NUMBER INDEX.

(1) *FIG. Column.* This column lists the number of the figure where the item is identified/located in Section II and III.

(2) *ITEM Column.* The item number is that number assigned to the item as it appears in the figure referenced in the adjacent figure number column.

(3) *STOCK NUMBER Column.* This column lists the NSN for the item.

(4) *CAGEC Column.* The Commercial and Government Entity Code (CAGEC) is a 5-digit numeric code used to identify the manufacturer, distributor, or Government agency, etc., that supplies the item.

(5) *PART NUMBER Column.* Indicates the primary number used by the manufacturer (individual, firm, corporation, or Government activity), which controls the design and characteristics of the item by means of its engineering drawings, specifications standards, and inspection requirements to identify an item or range of items.

C-5. SPECIAL INFORMATION.

a. *USABLE ON CODE.* The Usable On Code appears in the lower left corner of the Description column heading. Usable on Codes are shown as "UOC...." in the Description Column (justified left) on the first line applicable item description/nomenclature. Uncoded items are applicable to all models. Identification of the usable on codes in the RPSTL are:

Code	<u>Used On</u>
FPA	JTACS (MEP-903B)
FPB	SICPS (MEP-903A)
LTG	WIN-T (MEP-903C)

ARMY TM 9-6115-670-14&P

b. *FABRICATION INSTRUCTIONS.* Bulk materials required to manufacture items are listed in the bulk material functional group of this RPSTL. Part numbers for bulk materials are also referenced in the description column of the line item entry for the item to be manufactured/fabricated. Detailed fabrication instructions for items source coded to be manufactured are found in the narrative.

c. *NATIONAL STOCK NUMBERS.* National stock numbers (NSNs) that are missing from "P" source coded items have been applied for and will be added to this TM by future change/revision when they are entered in the Army master file (AMDF). Until the NSNs are established and published, submit exception requisitions to: Commander, US Army Communication-Electronics Command and Fort Monmouth, ATTN: AMSEL-LC-MM, Ft. Monmouth, NJ 07703-5007 for the part required to support your equipment.

C-6. HOW TO LOCATE REPAIR PARTS.

a. *When NSN or Part Number is Not Known.*

(1) *First.* Using the table of contents, determine the assembly group or subassembly group to which the item belongs. This is necessary since figures are prepared for assembly groups and subassembly groups, and listings are divided into the same groups.

(2) *Second.* Find the figure covering the assembly group or subassembly group to which the item belongs.

(3) *Third.* Identify the item on the figure and use the Figure and Item Number Index to find the NSN.

b. *When NSN or Part Number is Known.*

(1) *First.* Using the index of NSNs and part numbers, find the pertinent NSN or part number. The NSN index is in NIIN sequence (para 4a(1)). The part numbers in the part number index are listed in ascending alphanumeric sequence (para 4b). Both indexes cross-reference you to the illustration figure and item number of the item you are looking for.

(2) *Second.* After finding the figure and item number, verify that the item is the one you are looking for, then locate the item number in the repair parts list for the figure.

C-7. ABBREVIATIONS.

APU	Auxiliary Power Unit
JTACS	Joint Tactical Area Communications System
SICPS	Standardization Integrated Common Post System

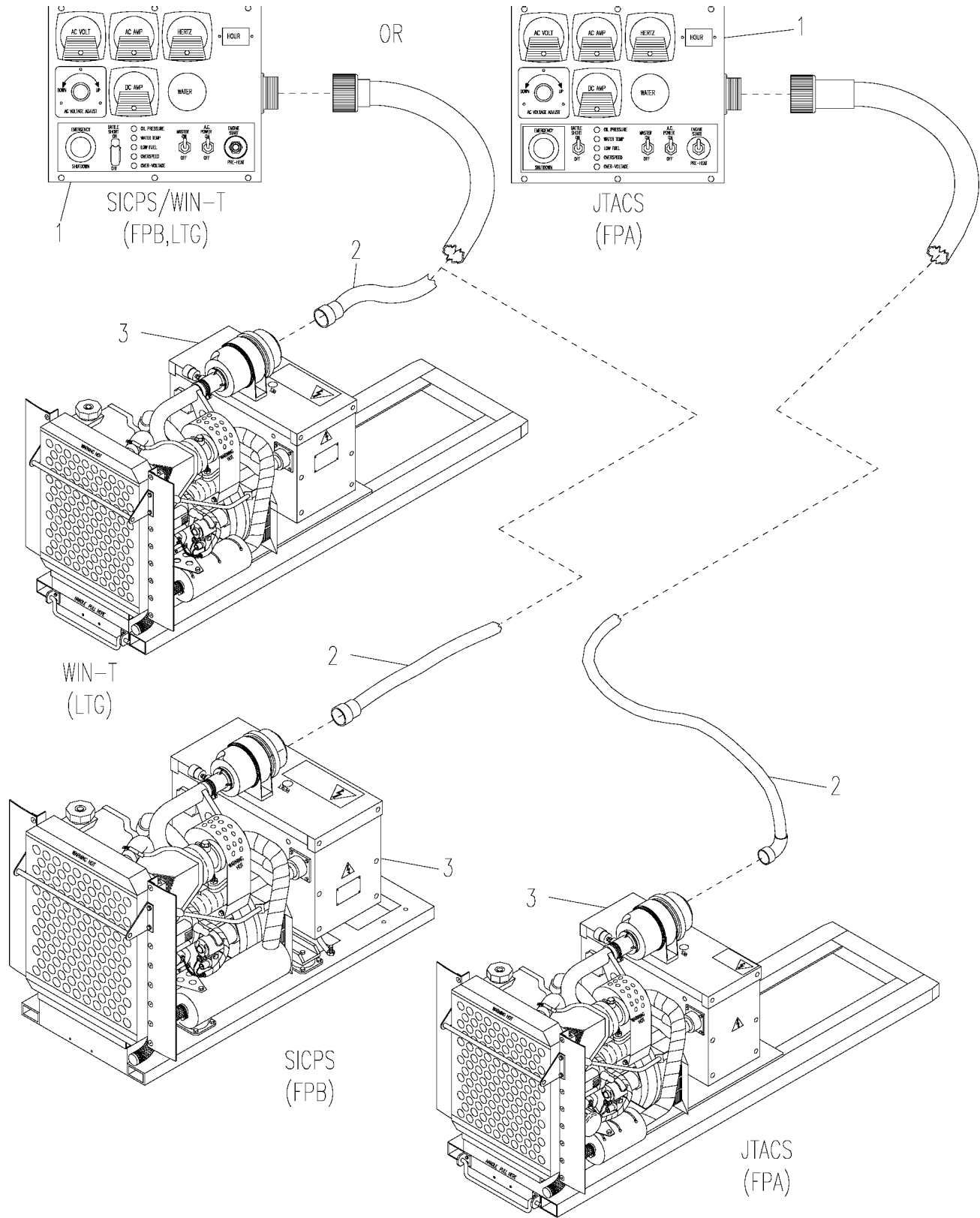

Figure C-1. Auxiliary Power Unit, 10 kW, 120/208 VAC, 60 Hz

Section II.

ARMY TM 9-6115-670-14&P

(1) Item No	(2) SMR CODE	(3) NSN	(4) CAGEC	(5) Part Number	(6) Description and Usable on Code (UOC)	(7) QTY
					GROUP 00 AUXILIARY POWER UNIT, 10KW 120/240V, 60 HZ	
					FIG C-1	
1	PAFFFA	6110-01-478-7200	97403	13230E6220	CONTROL BOX, GENERAT SEE FIGURE C-27 FOR BREAKDOWN.....	1
					UOC:FPB,ABC,LTG	
1	PAOFFA	6110-01-494-3003	29381	4831002C	CONTROL BOX, GENERAT SEE FIGURE C-27 FOR BREAKDOWN.....	1
					UOC:FPA	
2	PAFFFA	6150-01-482-4325	97403	13230E6308	WIRING HARNESS SEE FIGURE C-26 FOR BREAKDOWN.....	1
					UOC:ABC,FPB	
2	XBFFFA		29381	2233007A	WIRING HARNESS, CTRL SEE FIGURE C-26 FOR BREAKDOWN.....	1
					UOC:FPA	
2	XBFFFA		97403	13230E6847	WIRING HARNESS, CTRL SEE FIGURE C-26 FOR BREAKDOWN.....	1
					UOC:LTG	
3	XCFFFA		97403	13230E6300	GENERATOR, 903A SEE FIGURE C-2 FOR BREAKDOWN.....	1
					UOC:FPB	
3	XCFFFA		97403	13230E6816	GENERATOR, 903C SEE FIGURE C-2 FOR BREAKDOWN.....	1
					UOC:LTG	
3	XCFFFA		29381	7032916-501	GENERATOR, 903B SEE FIGURE C-2 FOR BREAKDOWN.....	1
					UOC:FPA	

End of Figure

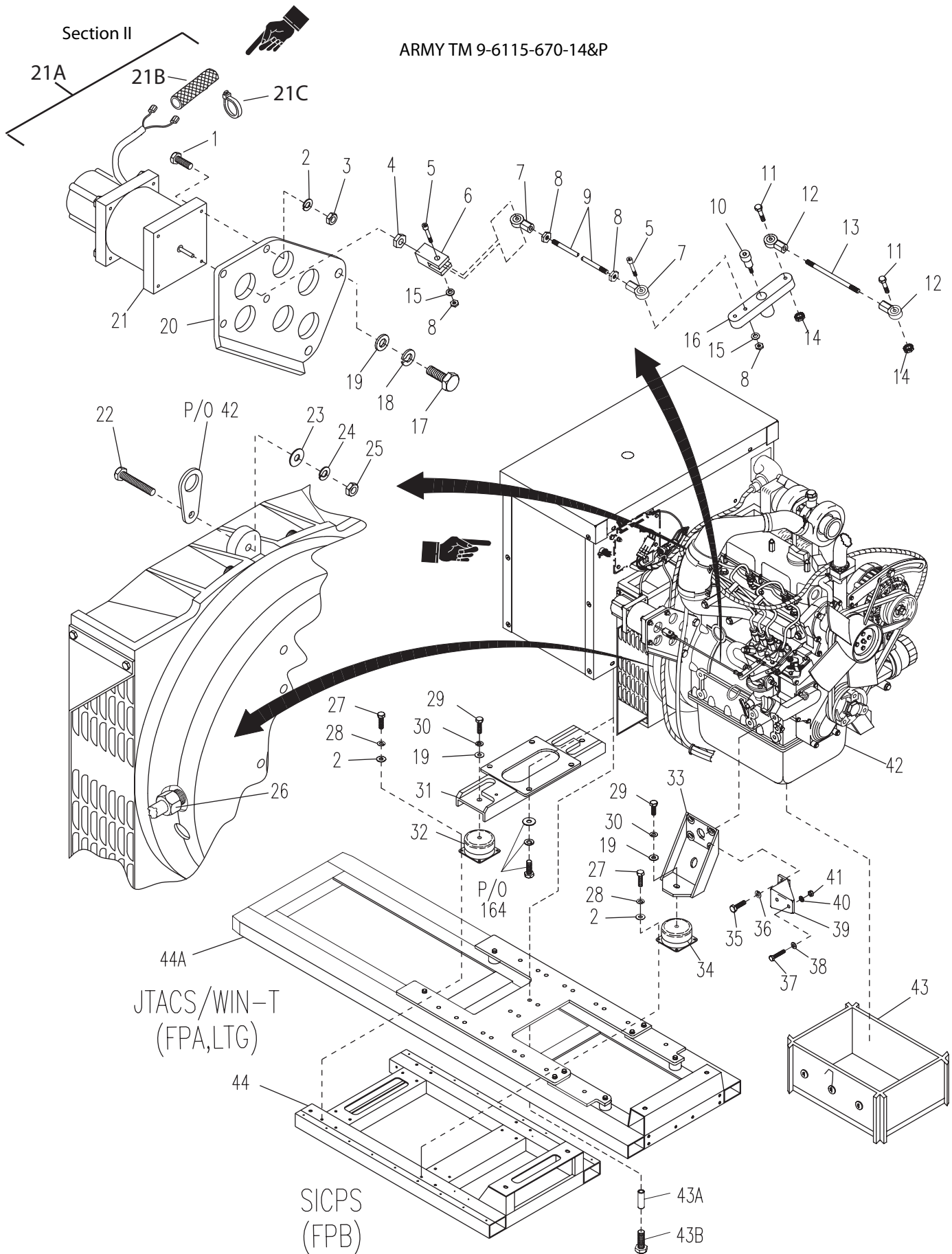

Figure C-2. Generator 10 kW, APU (Sheet 1 of 8)

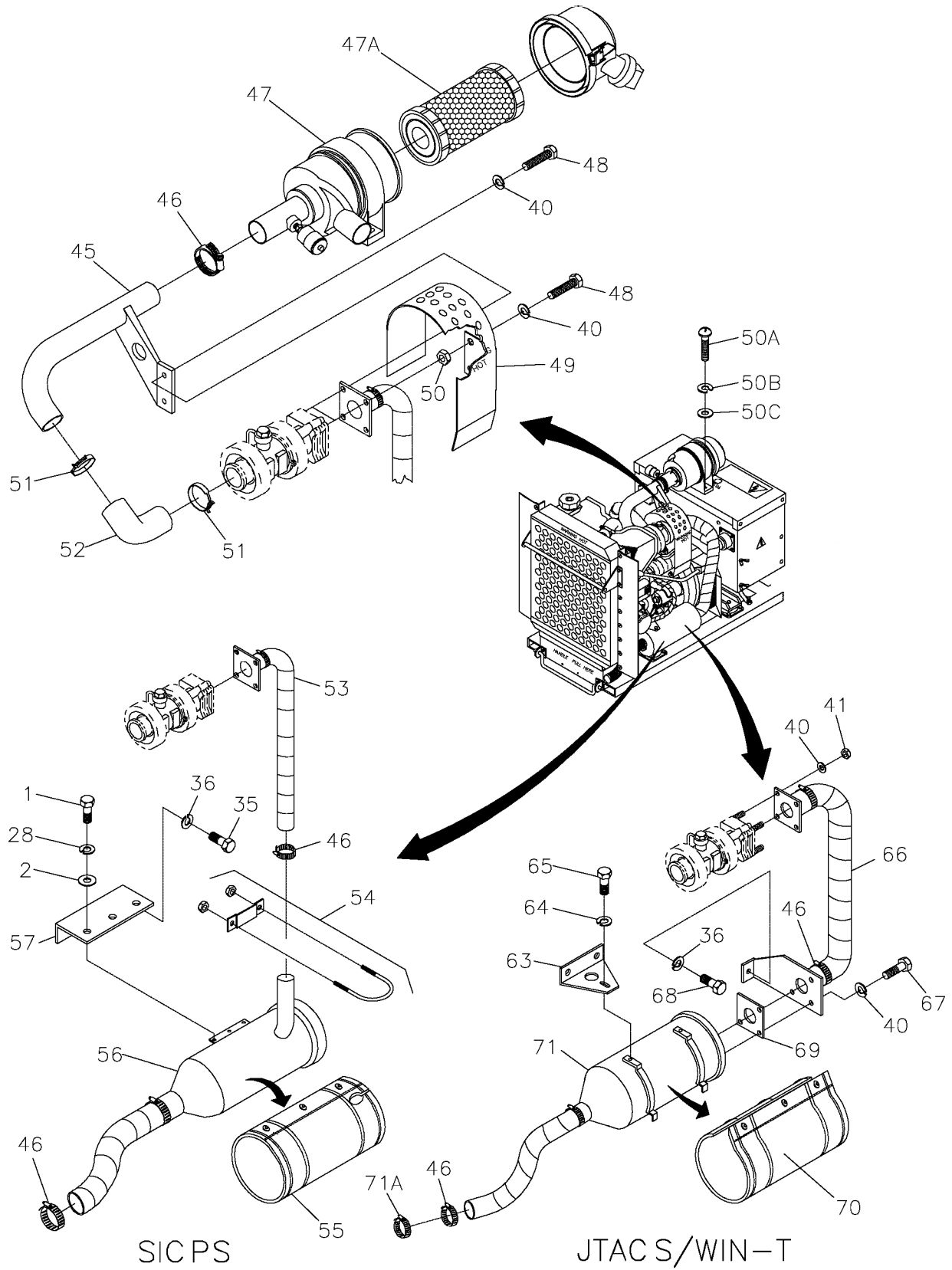

Figure C-2. Generator 10 kW, APU (Sheet 2 of 8)

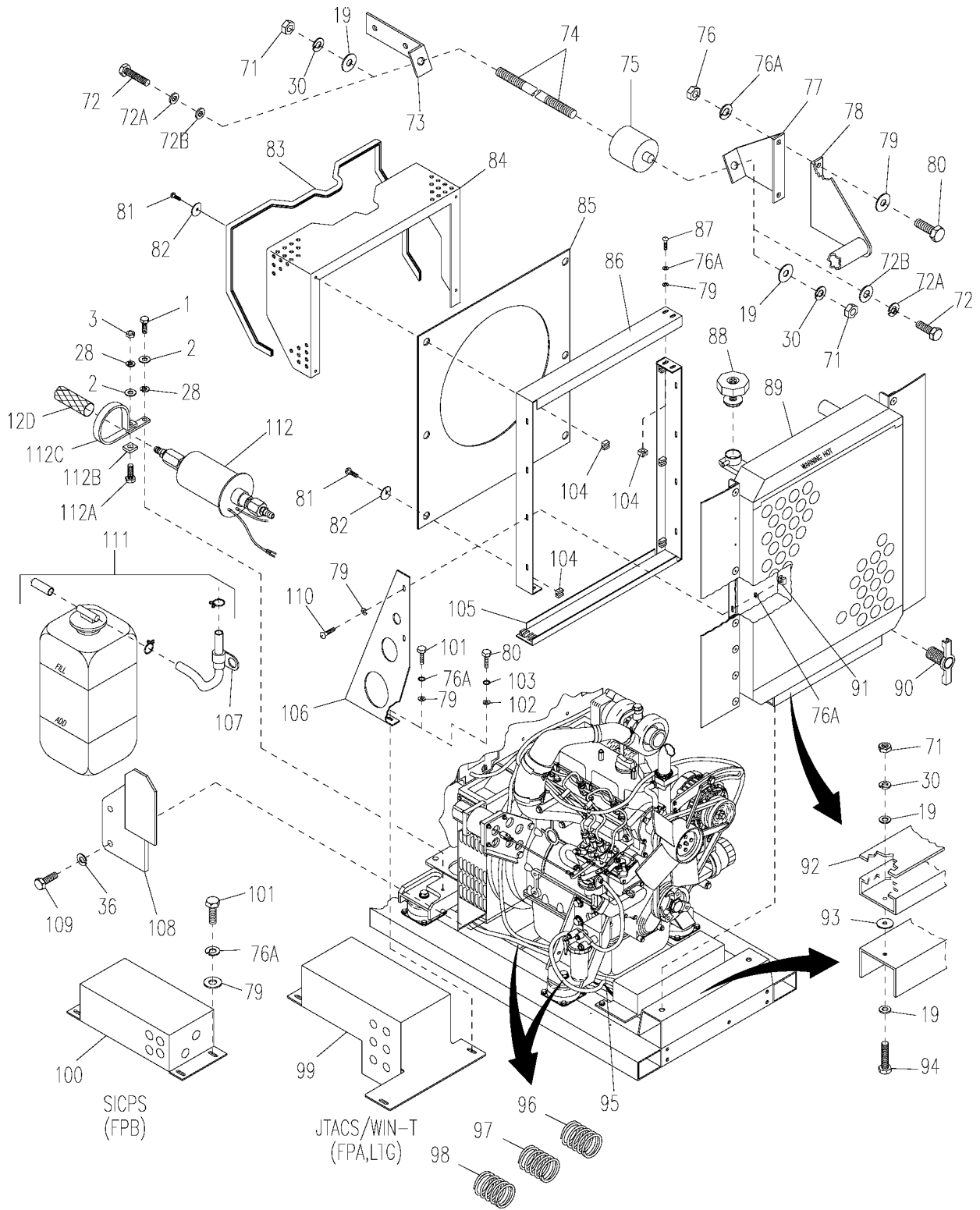

Figure C-2. Generator 10 kW, APU (Sheet 3 of 8)

Section II

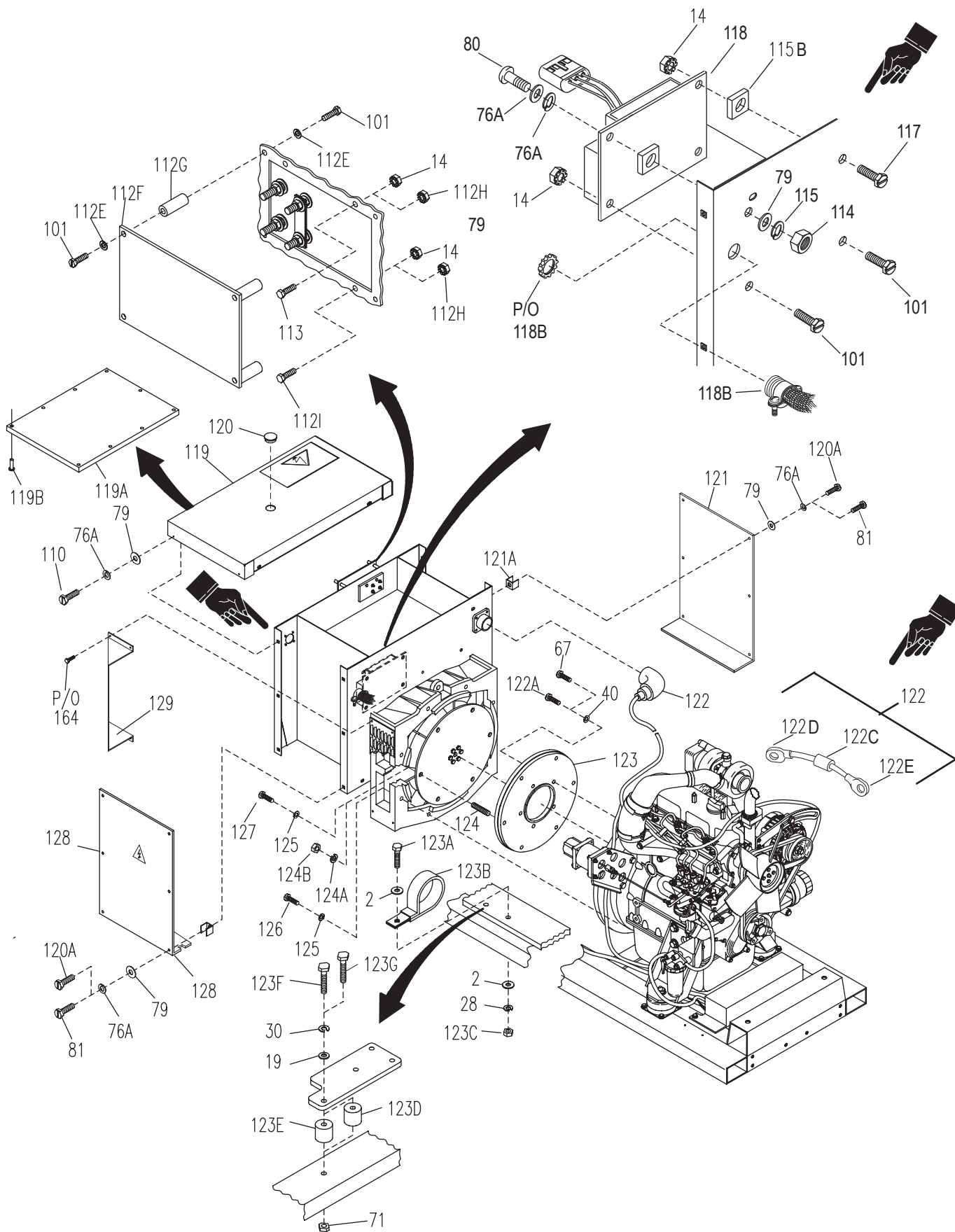

Figure C-2. Generator 10 kW, APU (Sheet 4 of 8)

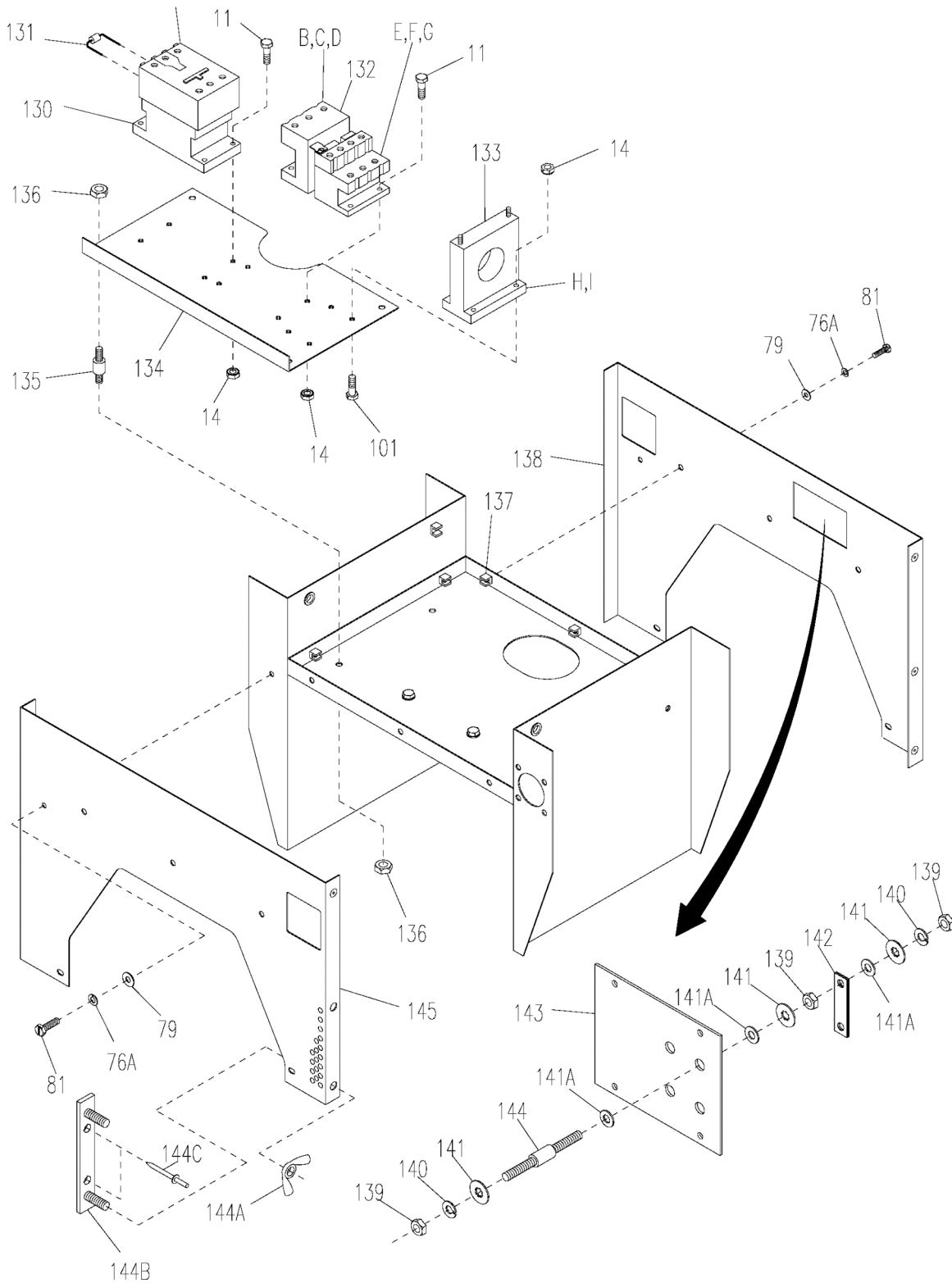

Figure C-2. Generator 10 kW, APU (Sheet 5 of 8)

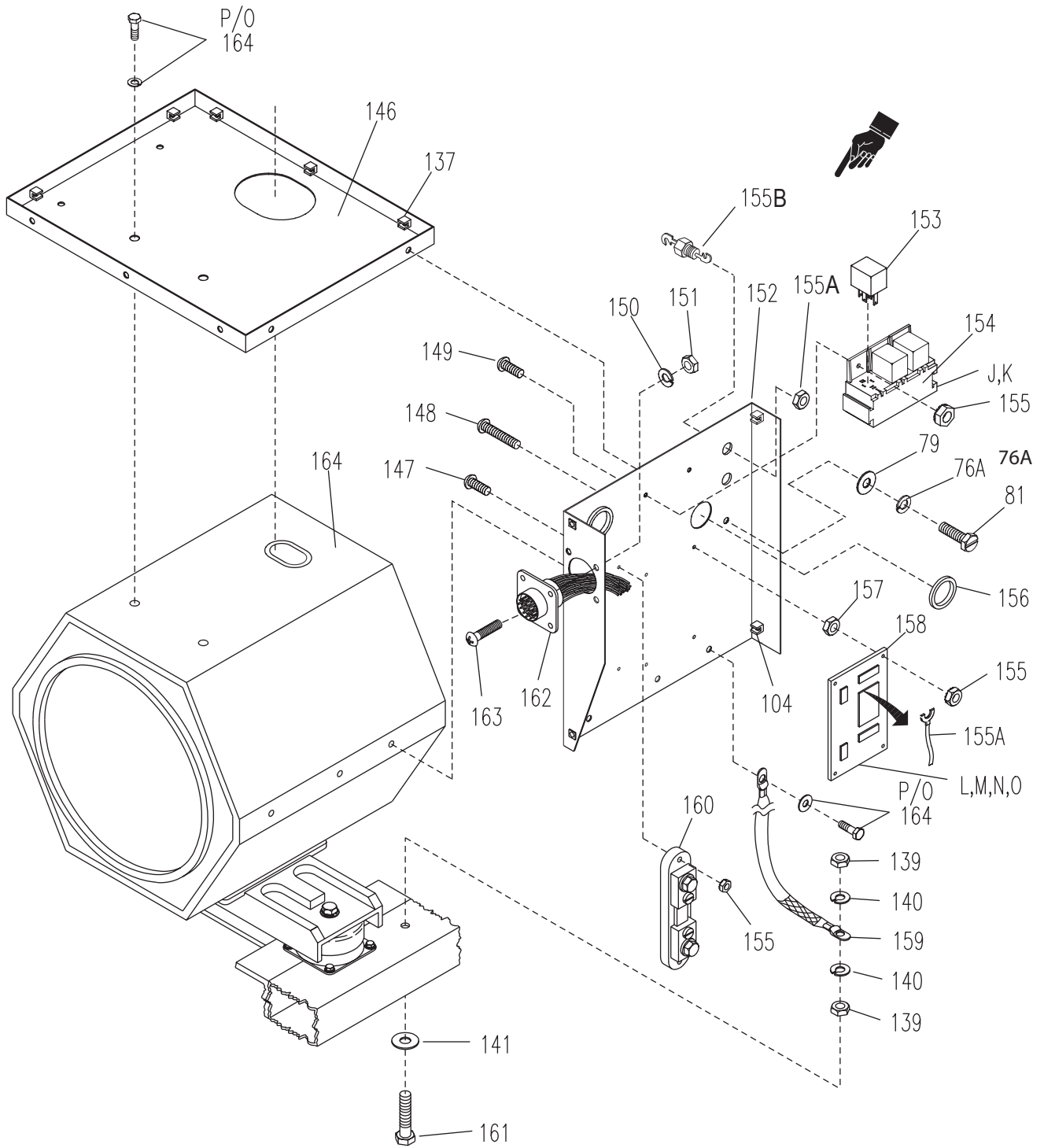

Figure C-2. Generator 10 kW, APU (Sheet 6 of 8)

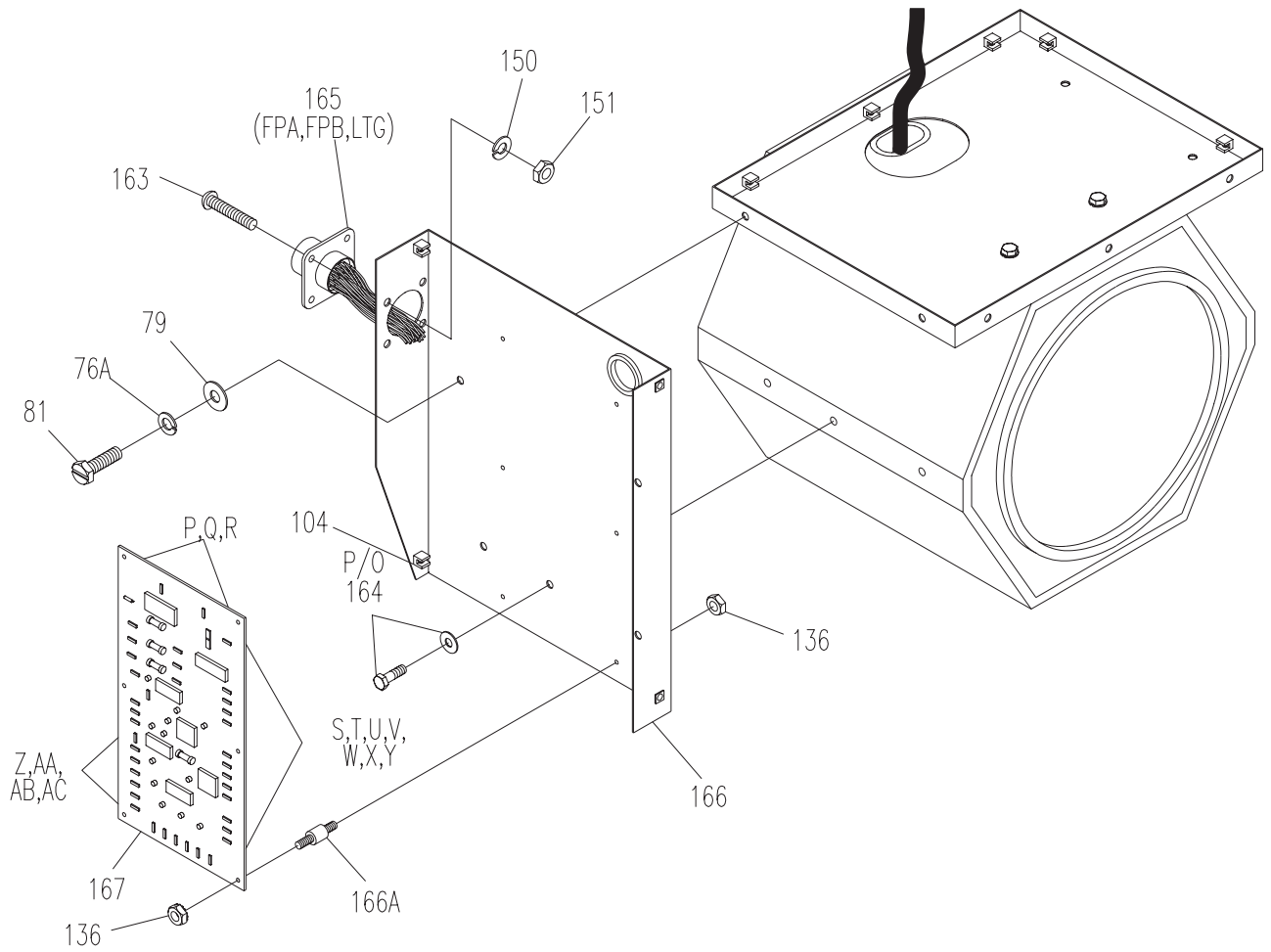

Figure C-2. Generator 10 kW, APU (Sheet 7 of 8)

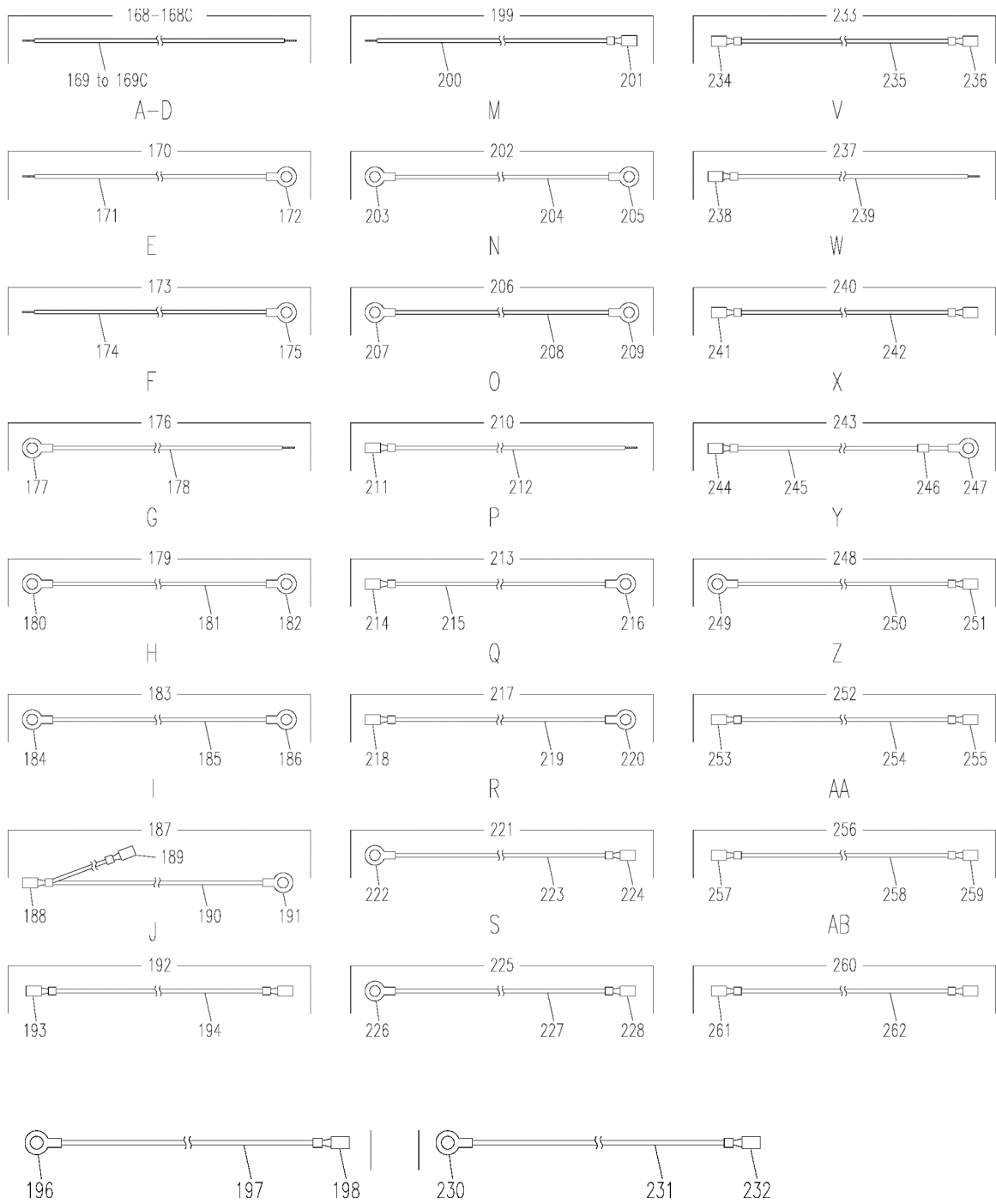

Figure C-2. Generator 10 kW, APU (Sheet 8 of 8)

Section II.

ARMY TM 9-6115-670-14&P

GROUP 1 GENERATOR 10KW,APU						
(1)	(2)	(3)	(4)	(5)	(6)	(7)
Item No	SMR CODE	NSN	CAGEC	Part Number	Description and Usable on Code (UOC)	QTY
GROUP 1 GENERATOR 10KW,APU						
FIG C-2						
1	PAOZZA	5305-01-479-1196	97403	13230E6674-98A	SCREW,MACHINE..... UOC:FPB	8
1	PAOZZA	5305-01-479-1196	97403	13230E6674-98A	SCREW,MACHINE..... UOC:LTG	5
1	PAFZZA	5306-01-500-6442	29381	1131002A	BOLT,MACHINE..... UOC:FPA	4
2	PAOZZA	5310-01-471-0633	30554	88-20033-20C	WASHER,FLAT..... UOC:ABC,FPB	25
2	PAOZZA	5310-01-471-0633	30554	88-20033-20C	WASHER,FLAT..... UOC:LTG	16
2	PAFZZA	5310-01-500-6114	29381	1313006A	WASHER,FLAT..... UOC:FPA	4
3	PAOZZA	5310-01-470-1981	30554	88-20568-1	NUT,PLAIN,CASTELLAT..... UOC:FPB,FPA,ABC,LTG	5
4	XDOZZA		05624	N1-1	.NUT,PLAIN,HEXAGON..... UOC:FPB,ABC,LTG	1
5	XBOZZA		05624	BYRF2516	.SCREW,CAP,SOCKET HD..... UOC:FPB,ABC,LTG	2
5	PAOZZA	5305-01-479-1198	97403	13230E6674-66A	SCREW,MACHINE..... UOC:FPA	2
6	XBOZZA		05624	DYNK218-2	.CLEVIS..... UOC:FPB,ABC,LTG	1
6	XBFZZA		29381	4230103A	CLEVIS..... UOC:FPA	1
7	XBOZZA		65149	AKKH175	.BEARING,PLAIN,ROD E..... UOC:FPB,FPA,ABC,LTG	2
8	XBOZZA		05624	DYRF29	.NUT,PLAIN,HEXAGON..... UOC:FPB,FPA,ABC,LTG	4
9	XBOZZA		05624	DYNK31-006	.ROD,THREADED..... UOC:FPB,ABC,LTG	1
9	MFFZZA		29381	1459027-7INCHES	ROD,THREADED..... UOC:FPA	1
10	XBOZZA	5305-01-479-5515	97403	13230E6669-5A	SCREW,SHOULDER..... UOC:FPA	1
10	PAFZZA	5305-01-500-3112	97403	13230E6669-6A	SCREW,MACHINE..... UOC:FPB,ABC,LTG	1
11	PAOZZA	5305-01-479-1198	97403	13230E6674-66A	SCREW,MACHINE..... UOC:FPB,ABC,LTG	6
12	PAOZZA	3120-00-554-6532	73134	HF3G	BEARING,PLAIN,ROD E..... UOC:FPB,ABC,LTG	2
12	PAFZZA	3120-01-500-4846	29381	3234001A	BALL,JOINT..... UOC:FPA	4
13	MOOZZA		81346	ASTMA582-1INCH	ROD,CONTIN THREAD MAKE FROM ROD,CONTIN THREAD P/N (81346) ATMA582; 1 H..... UOC:FPB,FPA,ABC,LTG	1
14	PAOZZA	5310-01-012-3595	30554	69-561-6	NUT,PLAIN,ASSEMBLED..... UOC:LTG	16
14	PAHZZA	5310-01-012-3595	30554	69-561-6	NUT,PLAIN,ASSEMBLED..... UOC:FPA	4
15	XBOZZA	5310-00-045-3296	96906	MS35338-43	.WASHER,LOCK..... UOC:FPB,FPA,ABC,LTG	2
16	XBOZZA		97403	13230E6337	PIVOT ARM,GOVERNOR..... UOC:FPB,ABC,LTG	1

Section II.

ARMY TM 9-6115-670-14&P

(1) Item No	(2) SMR CODE	(3) NSN	(4) CAGEC	(5) Part Number	(6) Description and Usable on Code (UOC)	(7) QTY
GROUP 1 GENERATOR 10KW,APU						
FIG C-2						
16	XBOZZA		97403	13230E6337	PIVOT ARM,GOVERNOR..... UOC:FPB,ABC,LTG	1
16	XBOZZA		29381	4230010E	PIVOT ARM,GOVERNOR..... UOC:FPA	1
17	PAOZZA	5306-00-226-4827	80204	B1821BH031C100N	BOLT,MACHINE..... UOC:FPA	2
17	PAOZZA	5305-01-479-1199	97403	13230E6674-118A	SCREW,MACHINE..... UOC:FPB,ABC,LTG	2
18	PAOZZA	5310-01-478-5719	97403	13230E6744-140	WASHER,LOCK..... UOC:FPB,ABC,LTG	2
18	PAOZZA	5310-01-500-6069	29381	1323007A	WASHER,LOCK..... UOC:FPA	2
19	PAOZZA	5310-01-478-6340	30554	88-20033-33C	. WASHER, FLAT..... UOC:ABC,FPB	13
19	PAOZZA	5310-01-500-5962	29381	1313008A	WASHER, FLAT..... UOC:FPA	4
19	PAOZZA	5310-01-478-6340	30554	88-20033-33C	WASHER, FLAT..... UOC:LTG	29
20	XBOZZA		97403	13230E6297	BRACKET,GOVERNOR..... UOC:FPB,ABC,LTG	1
20	XBOZZA		29381	4210020C	BRACKET,GOVERNOR..... UOC:FPA	1
21	PAOZZA	2910-01-486-2144	05624	DYNC-10502-000-0 -24	ACTUATOR,ELECTRO-ME..... UOC:LTG,FPB,FPA	1
21	PAOOOA		97403	13230E6976	ACTUATOR ASSEMBLY..... UOC:ABC	1
21A	PAOZZA	2910-01-486-2144	05624	DYNC-10502-000-0 -24	ACTUATOR,ELECTRO-ME..... UOC:ABC	1
21B	MOOOZA		97403	13230E6973-26-12 INCH	BRAID,WIRE..... UOC:ABC	1
21C	PAOZZA	5975-00-111-3208	81343	MS3367-5-9	STRAP,TIEDOWN,ELECT..... UOC:ABC	1
22	PAOZZA	5306-00-226-4829	80204	B1821BH031C125N	BOLT,MACHINE..... UOC:FPB,ABC,LTG	1
22	PAFZZA	5306-01-500-6407	29381	1132002A	BOLT,MACHINE..... UOC:FPA	1
23	PAOZZA	5310-00-044-6477	96906	MS51412-25	WASHER,FLAT..... UOC:FPB,ABC,LTG	1
23	PAOZZA	5310-01-478-6344	30554	88-20033-5C	WASHER,FLAT..... UOC:FPA	1
24	PAOZZA	5310-01-478-5780	97403	13230E6744-45	WASHER,LOCK..... UOC:FPB,ABC,LTG	1
25	PAOZZA	5310-00-767-0445	96906	MS51971-2	NUT,PLAIN,HEXAGON..... UOC:FPB,ABC,LTG	1
26	XCOOOA		97403	13230E6340	SPEED SENSOR ASSY SEE FIGURE C-19 FOR BREAKDOWN..... UOC:LTG,FPB,FPA	1
26	PAOOOA		97403	13230E6966	SPEED SENSOR ASSY SEE FIGURE C-19 FOR BREAKDOWN..... UOC:ABC	1
27	PAOZZA	5305-01-479-1190	97403	13230E6674-96A	. SCREW,MACHINE..... UOC:ABC,FPB	16
28	PAOZZA	5310-00-933-8121	97403	13230E6744-139	. WASHER, LOCK..... UOC:ABC,FPB	27
28	PAOZZA	5310-00-933-8121	97403	13230E6744-139	WASHER, LOCK..... UOC:LTG	19

Section II.

ARMY TM 9-6115-670-14&P

(1) Item No	(2) SMR CODE	(3) NSN	(4) CAGEC	(5) Part Number	(6) Description and Usable on Code (UOC)	(7) QTY
GROUP 1 GENERATOR 10KW,APU						
FIG C-2						
29	PAOZZA	5305-01-479-1193	97403	13230E6674-139A	SCREW,MACHINE..... UOC:ABC,FPB	4
30	PAOZZA	5310-00-984-7042	96906	MS35338-141	WASHER,LOCK..... UOC:FPA,ABC,FPB	8
30	PAOZZA	5310-00-984-7042	96906	MS35338-141	WASHER,LOCK..... UOC:LTG	18
31	XBFZZA		97403	13230E6318	.MOUNT,GENERATOR..... UOC:ABC,FPB	1
31	XBFZZA		29381	4250014C	MOUNT,GENERATOR REA..... UOC:FPA	1
32	PAOZZA	5342-00-684-9456	99687	344-1013P7	MOUNT,RESILIENT..... UOC:ABC,FPB	2
33	XBOZZA		97403	13230E6315	MOUNT,ENGINE..... UOC:FPB,ABC,LTG	2
33	XBOZZA		29381	4250005B	MOUNT,ENGINE..... UOC:FPA	2
34	PAOZZA	5340-00-818-6806	81860	C2060T6	.MOUNT,RESILIENT..... UOC:ABC,FPB	2
35	PAOZZA	5305-01-480-4690	I9008	ISO8676-M10X1.25 X25-8.8	SCREW,CAP,HEXAGON H..... UOC:LTG	8
35	PAOZZA	5305-01-480-4690	I9008	ISO8676-M10X1.25 X25-8.8	SCREW,CAP,HEXAGON H..... UOC:ABC,FPB	9
36	PAOZZA	5310-01-478-5622	80204	B18212HRCZ100	WASHER,LOCK..... UOC:ABC,FPB	11
36	PAOZZA	5310-01-478-5622	80204	B18212HRCZ100	WASHER,LOCK..... UOC:LTG	10
36	PAOZZA	5310-01-500-5958	29381	1324005A	WASHER,LOCK..... UOC:FPA	11
37	PAOZZA	5306-01-478-8895	80204	B18235B08070N	BOLT,MACHINE..... UOC:FPB,ABC,LTG	1
37	PAOZZA	5306-01-500-5939	29381	1143004A	BOLT,MACHINE..... UOC:FPA	1
38	PAOZZA	5310-01-418-2334	80204	B1822BS080R	WASHER,FLAT..... UOC:FPB,ABC,LTG	1
38	PAOZZA	5310-01-500-6111	29381	1314004A	WASHER,FLAT..... UOC:FPA	1
39	XBOZZA		97403	13230E6314	BRACKET,FUEL FILTER..... UOC:FPB,ABC,LTG	1
39	XBOZZA		29381	4210261A	BRACKET,FUEL FILTER..... UOC:FPA	1
40	PAOZZA	5310-01-478-5620	80204	B18212HRCZ080	WASHER,LOCK..... UOC:ABC,FPB	10
40	PAOZZA	5310-01-478-5620	80204	B18212HRCZ080	WASHER,LOCK..... UOC:LTG	13
40	PAOZZA	5310-01-500-6066	29381	1324004A	WASHER,LOCK..... UOC:FPA	9
41	PAOZZA	5310-01-328-7657	80204	B18241B080	NUT,PLAIN,HEXAGON..... UOC:FPB,ABC,LTG	1
41	PAOZZA	5310-01-328-7657	80204	B18241B080	NUT,PLAIN,HEXAGON..... UOC:FPA	3
42	XBFHHA		97403	13230E6324	ENGINE ASSY SEE FIGURE C-7 FOR BREAKDOWN..... UOC:FPB,ABC,LTG	1
42	XBFHHA		29381	3112004E	ENGINE ASSY,903B SEE FIGURE C-7 FOR BREAKDOWN..... UOC:FPA	1

Section II.

ARMY TM 9-6115-670-14&P

(1) Item No	(2) SMR CODE	(3) NSN	(4) CAGEC	(5) Part Number	(6) Description and Usable on Code (UOC)	(7) QTY
GROUP 1 GENERATOR 10KW,APU						
FIG C-2						
41	PAOZZA	5310-01-328-7657	80204	B18241B080	NUT,PLAIN,HEXAGON..... UOC:FPA	3
42	XBFHHA		97403	13230E6324	ENGINE ASSY SEE FIGURE C-7 FOR BREAKDOWN..... UOC:FPB,ABC,LTG	1
42	XBFHHA		29381	3112004E	ENGINE ASSY,903B SEE FIGURE C-7 FOR BREAKDOWN..... UOC:FPA	1
43	XBOZZA		97403	13230E6333	COVER,THERMAL..... UOC:FPA,ABC,FPB,LTG	1
43A	PAOZZA	3120-01-500-4911	97403	13230E6875	BUSHING,SLEEVE..... UOC:LTG	4
43B	PAOZZA	5305-12-126-7056	D8286	DIN912M10X35-8-8	SCREW,CAP,SOCKET HE..... UOC:LTG	4
44	XBFFFA		97403	13230E6328	.FRAME,903A SEE FIGURE C-3 FOR BREAKDOWN..... UOC:ABC,FPB	1
44A	XBFFFA		97403	13230E6649	.FRAME,903C SEE FIGURE C-4 FOR BREAKDOWN..... UOC:LTG	1
44A	XBFFFA		29381	4820046B	.FRAME ASSY,903B SEE FIGURE C-4 FOR BREAKDOWN..... UOC:FPA	1
45	XBOZZA		97403	13230E6329	PIPE,INTAKE..... UOC:FPB,ABC,LTG	1
45	XBOZZA		29381	3124030B	TUBE,INTAKE..... UOC:FPA	1
46	PAOZZA	4730-01-470-1567	30554	88-20561-3	CLAMP,HOSE..... UOC:ABC,FPB	8
46	PAOZZA	4730-01-470-1567	30554	88-20561-3	CLAMP,HOSE..... UOC:LTG	7
46A	PAOZZA		97403	13230E6681-4A	SCREW,TAPPING..... UOC:ABC	1
47	AOOZZA	2940-01-479-1450	97403	13230E6813	AIR CLEANER,INTAKE..... UOC:FPB,FPA,ABC,LTG	1
47A	PAOZZA	2940-01-500-3734	18265	P831520	FILTER ELEMENT,INTA..... UOC:FPB,FPA,ABC,LTG	1
48	PAOZZA	5306-01-478-8896	80204	B18235B08016N	BOLT,MACHINE..... UOC:FPB,ABC,LTG	4
48	PAOZZA	5305-01-500-3540	97403	13218E0493-1810P IIC	SCREW,MACHINE..... UOC:FPA	1
49	XBOZZA		97403	13230E6334	GUARD,TURBO..... UOC:FPB,ABC,LTG	1
49	XBOZZA		29381	4210061C	GUARD,TURBO..... UOC:FPA	1
50	PAOZZA	5310-01-500-6149	29381	1224012A	NUT,PLAIN,ASSEMBLED..... UOC:FPA	1
51	PAOZZA	5305-01-500-3535	97403	13230E6674-68A	SCREW,MACHINE..... UOC:LTG	2
52	PAOZZA	5310-01-500-2428	97403	13230E6744-43	WASHER,LOCK..... UOC:LTG	2
53	PAOZZA	5310-01-500-2482	30554	88-20033-11A	WASHER,FLAT..... UOC:LTG	2
54	PAOZZA	2990-01-478-5686	97403	13230E6791	PIPE,EXHAUST..... UOC:LTG	1
54	PAOZZA	2990-01-500-5964	29381	3123014A	PIPE,EXHAUST..... UOC:FPA	1
55	PAOZZA	5306-01-478-8880	80204	B18235B08020N	BOLT,MACHINE..... UOC:LTG	8

Section II.

ARMY TM 9-6115-670-14&P

(1) Item No	(2) SMR CODE	(3) NSN	(4) CAGEC	(5) Part Number	(6) Description and Usable on Code (UOC)	(7) QTY
GROUP 1 GENERATOR 10KW,APU						
FIG C-2						
55	PAOZZA	5306-01-478-8880	80204	B18235B08020N	BOLT, MACHINE..... UOC:LTG	8
55	PAOZZA	5306-01-500-2740	29381	1143002A	BOLT, MACHINE..... UOC:FPA	3
56	PAOZZA	5330-01-446-2136	0XWR1	15263-12370	. GASKET..... UOC:FPB, FPA, ABC, LTG	1
57	PAOZZA	2990-21-921-2413	0X832	FSP3X9	GUARD, MUFFLER-EXHAU..... UOC:FPA, LTG	1
58	PAOZZA	5305-01-480-4690	I9008	ISO8676-M10X1.25 X25-8.8	SCREW, CAP, HEXAGON H..... UOC:FPA	1
59	PAOZZA	5306-01-478-8897	80204	B18235B06010N	BOLT, MACHINE..... UOC:LTG	1
59	PAOZZA	5306-01-500-6406	29381	1142001A	BOLT, MACHINE..... UOC:FPA	1
60	PAOZZA	5310-01-478-5935	05047	W212NAA0060NN041 NNCG1	WASHER, LOCK..... UOC:LTG	1
60	PAOZZA	5310-01-500-6062	29381	1324003A	WASHER, LOCK..... UOC:FPA	1
61	XBOZZA		97403	13230E6792	BRACE, MUFFLER..... UOC:LTG	1
61	XBOZZA		29381	4110034F	BRACE, MUFFLER SUP..... UOC:FPA	1
62	PAOZZA	2990-01-478-5724	97403	13230E6688	MUFFLER, EXHAUST..... UOC:LTG	1
62	PAOZZA	2990-01-500-6477	29381	3123006A	MUFFLER, EXHAUST..... UOC:FPA	1
63	XDOZZA		81646	6320	CLAMP, HOSE..... UOC:FPA	4
64	PAOZZA	2990-01-485-7699	97403	13230E6317	GUARD, MUFFLER-EXHAU..... UOC:ABC, FPB	1
65	PAOZZA	2990-01-478-6488	97403	13230E6327	. MUFFLER, EXHAUST-INT..... UOC:ABC, FPB	1
66	XBOZZA		97403	13230E6316	. BRACKET, MUFFLER..... UOC:ABC, FPB	1
67	PAOZZA	5340-01-478-7608	58536	AA572406-3-SB	. CLAMP, LOOP..... UOC:ABC, FPB	1
68	PAOZZA	2990-01-478-6489	97403	13230E6310	PIPE, EXHAUST..... UOC:ABC, FPB	1
69	PAOZZA	4730-01-133-2350	59119	UM4073	CLAMP, HOSE..... UOC:FPA	2
70	XDOZZA		97403	13230E6335	HOSE, NON-METALLIC..... UOC:LTG, FPB	1
70	PAOZZA	4720-01-500-5575	29381	5241017A	HOSE, PREFORMED..... UOC:FPA	1
70	MOOZZA		97403	13230E6300 ITEM 209	HOSE, NONMETALLIC..... UOC:ABC	1
71	PAOZZA	5310-00-913-8881	97403	13218E0320-293	. NUT, PLAIN, HEXAGON..... UOC:ABC, FPB	5
71	PAOZZA	5310-00-913-8881	97403	13218E0320-293	NUT, PLAIN, HEXAGON..... UOC:LTG	9
72	PAOZZA	5306-01-500-2668	29381	1132006A	BOLT, MACHINE..... UOC:FPA	2
72A	PAOZZA	5310-01-500-6069	29381	1323007A	WASHER, LOCK..... UOC:FPA	2
72B	PAOZZA	5310-01-478-6344	30554	88-20033-5C	WASHER, FLAT..... UOC:FPB, ABC, LTG	3

Section II.

ARMY TM 9-6115-670-14&P

(1) Item No	(2) SMR CODE	(3) NSN	(4) CAGEC	(5) Part Number	(6) Description and Usable on Code (UOC)	(7) QTY
GROUP 1 GENERATOR 10KW,APU						
FIG C-2						
73	XBOZZA		97403	13230E6645	. BRACKET, GENERATOR..... UOC: FPB, ABC, LTG	1
73	XBOZZA		29381	4210230A	BRACKET, SUPPORT MTG..... UOC: FPA	1
74	PAOZZA	5306-01-479-3983	97403	13230E6347	. ROD, THREADED END..... UOC: FPB, ABC, LTG	1
74	XBOZZA		29381	4230092B	ROD, RADIATOR SUPPOR..... UOC: FPA	1
75	PAOZZA	5342-01-478-7900	97403	13230E6644-1	. MOUNT, RESILIENT, WEA..... UOC: FPB, ABC, LTG	1
75	PAOZZA	2815-01-500-6987	29381	4610002A	DAMPNER, VIBRATION, E..... UOC: FPA	1
76	PAOZZA	5310-01-498-9981	97403	13218E0320-89	. NUT, PLAIN, HEXAGON..... UOC: FPB, ABC, LTG	4
76	PAOZZA	5310-01-012-3595	30554	69-561-6	NUT, PLAIN, ASSEMBLED..... UOC: FPA	3
76A	PAOZZA	5310-00-933-8120	80205	MS35338-138	. WASHER, LOCK..... UOC: FPB, ABC, LTG	51
77	XBOZZA		97403	13230E6346	BRACKET, SUPPORT..... UOC: FPB, ABC, LTG	1
77	XBOZZA		29381	4210229A	BRACKET, RAD SUPPORT..... UOC: FPA	1
78	XBOZZA		97403	13230E6345	BRACKET, PUSH HANDLE..... UOC: FPB, ABC, LTG	1
78	XBOZZA		29381	4250082A	HANDLE, PUSH..... UOC: FPA	1
79	PAOZZA	5310-01-471-0640	30554	88-20033-11C	. WASHER, FLAT..... UOC: ABC, FPB	51
79	PAOZZA	5310-01-471-0640	30554	88-20033-11C	WASHER, FLAT..... UOC: LTG	47
79	PAOZZA	5310-01-500-5960	29381	1313004A	WASHER, FLAT..... UOC: FPA	8
80	PAOZZA	5305-01-479-1198	97403	13230E6674-66A	SCREW, MACHINE..... UOC: FPA	8
80	PAOZZA	5305-01-479-1206	97403	13230E6674-67A	SCREW, MACHINE..... UOC: FPB, ABC, LTG	5
81	PAOZZA	5305-01-479-1181	97403	13230E6674-75A	. SCREW, MACHINE..... UOC: FPB, ABC, LTG	32
81	PAHZZA	5305-01-500-6912	29381	1434011A	SCREW, MACHINE..... UOC: FPA	18
82	PAOZZA	5310-01-478-5208	97403	13230E6294	WASHER, FLAT..... UOC: FPB, ABC, LTG	6
82	PAOZZA	5310-01-500-6118	29381	4210045A	WASHER, FLAT..... UOC: FPA	6
83	MOOZZA		97403	13230E6292-1-46I NCH	NONMETALLIC CHANNEL MAKE FROM NONMETALLIC CHANNEL P/N (97403) 13230E629 ; 46 INCHES..... UOC: FPB, ABC, LTG	1
84	XBOZZA		97403	13230E6289	GUARD, FAN..... UOC: FPB, ABC, LTG	1
84	XBOZZA		29381	4210044A	GUARD, FAN..... UOC: FPA	1
85	XBOZZA		97403	13230E6287	SHROUD, FAN..... UOC: FPB, ABC, LTG	1
85	XBOZZA		29381	4210042B	SHROUD, FAN..... UOC: FPA	1

Section II.

ARMY TM 9-6115-670-14&P

(1) Item No	(2) SMR CODE	(3) NSN	(4) CAGEC	(5) Part Number	(6) Description and Usable on Code (UOC)	(7) QTY
GROUP 1 GENERATOR 10KW,APU						
FIG C-2						
85	XBOZZA		29381	4210042B	SHROUD,FAN..... UOC:FPA	1
86	XBOZZA		97403	13230E6290	HOUSING,SHROUD..... UOC:FPB,ABC,LTG	1
86	XBOZZA		29381	4210009C	SHROUD,HOUSING RT..... UOC:FPA	1
87	PAOZZA	5305-01-479-1201	97403	13230E6674-74A	SCREW,MACHINE..... UOC:FPB,ABC,LTG	4
88	PAOZZA	2930-01-146-3634	72853	10230	CAP,FILLER OPENING..... UOC:FPB,FPA,ABC,LTG	1
89	PAFHHA	2930-01-479-1801	97403	13230E6282	RADIATOR,ENGINE COO SEE FIGURE C-18 FOR BREAKDOWN..... UOC:ABC,FPB	1
89	PAFHHA	2935-01-494-6331	29381	3125002B	RADIATOR,ENGINE COO SEE FIGURE C-18 FOR BREAKDOWN..... UOC:FPA	1
89	PAFHHA	2935-01-494-6330	97403	13230E6846	RADIATOR,ENGINE COO SEE FIGURE C-18 FOR BREAKDOWN..... UOC:LTG	1
90	PAOZZA	4820-01-381-5079	79470	52487	COCK,DRAIN..... UOC:FPB,ABC,LTG	1
90	PAOZZA	4820-00-849-1220	96906	MS35782-5	COCK,DRAIN..... UOC:FPA	1
91	PROZZA	5305-01-479-1189	97403	13230E6674-138A	.SCREW,MACHINE..... UOC:FPB,FPA,ABC,LTG	2
91	PAOZZA	5310-01-197-3108	78553	C7941-1024-3B	.NUT,PLAIN,SQUARE..... UOC:FPB,ABC,LTG	8
92	XBOZZA		97403	13230E6874	SHIM,RADIATOR..... UOC:LTG	1
93	PAFZZA	5310-01-478-4828	97403	13230E6326	.WASHER,FLAT..... UOC:ABC,FPB	2
94	PAOZZA	5306-01-500-2665	29381	1133003A	BOLT,MACHINE..... UOC:FPA	2
94	PAOZZA	5305-01-479-1189	97403	13230E6674-138A	.SCREW,MACHINE..... UOC:ABC,FPB	2
94	PAOZZA	5305-01-479-1189	97403	13230E6674-138A	SCREW,MACHINE..... UOC:LTG	12
95	XBOOOA		97403	13230E6878	HOSE ASSEMBLY,FUEL..... UOC:LTG	1
96	MFFZZA	5975-01-500-7275	97403	13230E6820-3	CONDUIT,NONMETALLIC..... UOC:LTG,FPB,ABC	1
97	MFFZZA	5975-01-500-7273	97403	13230E6820-4	CONDUIT,NONMETALLIC..... UOC:LTG,FPB,ABC	3
98	PROZZA	5305-01-479-1186	97403	13230E6674-76A	.SCREW,MACHINE..... UOC:FPB,FPA,ABC,LTG	16
98	MFFZZA		97403	13230E6820-1	LOOM,PLASTIC FLEX..... UOC:FPA	1
99	XCOOOA		97403	13230E6821	FUEL TANK ASSY,903C SEE FIGURE C-6 FOR BREAKDOWN..... UOC:LTG	1
99	XCOOOA		29381	4820045B	FUEL TANK ASSY,903B SEE FIGURE C-6 FOR BREAKDOWN..... UOC:FPA	1
100	XCOOOA		97403	13230E6299	.FUEL TANK ASSY,903A SEE FIGURE C-5 FOR BREAKDOWN..... UOC:ABC,FPB	1

Section II.

ARMY TM 9-6115-670-14&P

(1) Item No	(2) SMR CODE	(3) NSN	(4) CAGEC	(5) Part Number	(6) Description and Usable on Code (UOC)	(7) QTY
GROUP 1 GENERATOR 10KW,APU						
FIG C-2						
101	PAOZZA	5305-01-479-1180	97403	13230E6674-64A	. SCREW, MACHINE..... UOC: ABC, FPB	14
101	PAOZZA	5305-01-479-1180	97403	13230E6674-64A	SCREW, MACHINE..... UOC: LTG	18
102	PAOZZA	5310-01-500-2416	97403	13230E6743-39A	WASHER, LOCK..... UOC: FPA	2
103	PAOZZA	5310-01-500-5960	29381	1313004A	WASHER, FLAT..... UOC: FPA	2
104	PAOZZA	5340-00-977-3992	78553	C7931-1024-3B	. RETAINER, NUT AND BO..... UOC: FPB, ABC, LTG	25
104	PAHZZA	5325-01-500-5761	29381	1224201A	INSERT, FASTNER..... UOC: FPA	18
105	XBOZZA		97403	13230E6291	HOUSING, SHROUD..... UOC: FPB, ABC, LTG	1
105	XBOZZA		29381	4210008D	SHROUD, HOUSING LEFT..... UOC: FPA	1
106	XBOZZA		97403	13230E6286	. BRACKET, RADIATOR..... UOC: ABC, FPB	1
106	XBOZZA		29381	4210023C	BRACKET, RADIATOR..... UOC: FPA	1
106	XBOZZA		97403	13230E6867-2	BRACKET, RADIATOR..... UOC: LTG	1
107	PAOZZA	5340-01-478-7430	30554	88-20037WWDG8	CLAMP, LOOP..... UOC: FPB, ABC, LTG	2
107	PAOZZA	5340-01-500-5952	29381	1743102A	CLAMP, LOOP..... UOC: FPA	4
108	XBOZZA		97403	13230E6342	. BRKT, OVERFLOW TANK..... UOC: FPB, ABC, LTG	1
108	XBOZZA		29381	4250081A	BRACKET, OVERFLOW TA..... UOC: FPA	1
109	PAOZZA	5305-01-480-4686	I9008	ISO8676-M10X1.25 X20-8.8	SCREW, CAP, HEXAGON H..... UOC: FPB, FPA, ABC, LTG	2
110	PAOZZA	5305-01-479-1186	97403	13230E6674-76A	. SCREW, MACHINE..... UOC: LTG, FPB	16
110	PAOZZA	5305-01-479-1186	97403	13230E6674-76A	SCREW, MACHINE..... UOC: ABC	19
111	PAOZZA	4720-01-479-1362	97403	13230E6343	TANK, RADIATOR OVERF..... UOC: FPB, FPA, ABC, LTG	1
112	PAOOOA	2915-01-478-6910	97403	13230E6344	PUMP, FUEL, METERING SEE FIGURE C-17 FOR BREAKDOWN..... UOC: LTG, FPB	1
112	PAOZZA	2910-01-500-5950	29381	4821025A	PUMP, FUEL, ELECTRICA SEE FIGURE C-17 FOR BREAKDOWN..... UOC: FPA	1
112	PAOOOA		97403	13230E6970	PUMP ASSEMBLY, FUEL SEE FIGURE C-17 FOR BREAKDOWN..... UOC: ABC	1
112A	PAOZZA	5305-01-479-1197	97403	13230E6674-100A	SCREW, MACHINE..... UOC: LTG, FPB, ABC	1
112B	XBOZZA		97403	13230E6873	SPACER, FUEL PUMP..... UOC: LTG	1
112C	XBOZZA		97403	13230E6295	BRACKET, FUEL PUMP..... UOC: FPB, ABC, LTG	1
112D	XBOOOA		97403	13230E6877	HOSE ASSEMBLY, FUEL..... UOC: LTG	1
112E	PAOZZA	5310-01-500-6089	29381	1332102A	WASHER, LOCK..... UOC: FPA	8

Section II.

ARMY TM 9-6115-670-14&P

(1) Item No	(2) SMR CODE	(3) NSN	(4) CAGEC	(5) Part Number	(6) Description and Usable on Code (UOC)	(7) QTY
GROUP 1 GENERATOR 10KW,APU						
FIG C-2						
112F	XBOZZA		97403	13230E6271	.COVER,PROTECTIVE..... UOC:FPB,ABC,LTG	1
112F	XBOZZA		29381	4320001A	COVER,PROTECTIVE..... UOC:FPA	1
112G	XBOZZA		97403	13230E6273	.STAND OFF..... UOC:FPB,ABC,LTG	4
112G	XBOZZA		29381	4230022B	STAND OFF..... UOC:FPA	4
112H	PAOZZA	5310-01-500-6149	29381	1224012A	NUT,PLAIN,ASSEMBLED..... UOC:FPA	10
112I	PAOZZA	5305-01-479-1214	97403	13230E6673-66A	SCREW,MACHINE..... UOC:FPB,ABC,LTG	2
113	PAOZZA	5305-01-500-5968	29381	1452002A	SCREW,CAP, SOCKET HE..... UOC:FPA	10
113	PAOZZA	5342-01-478-7932	97403	13230E6274-1	MOUNT,RESILIENT..... UOC:FPB,ABC,LTG	2
114	PAOZZA	5310-01-478-9244	97403	13218E0320-129	NUT,PLAIN,HEXAGON..... UOC:FPB,FPA,ABC,LTG	2
114A	PAOZZA	5310-01-500-6182	29381	1224011A	NUT,SELF-LOCKING,AS..... UOC:FPA	2
115	PAOZZA	5310-01-478-5772	97403	13230E6744-100	WASHER,LOCK..... UOC:FPB,ABC,LTG	2
115A	PAOZZA		97403	13230E6967	SPACER,GOVERNOR..... UOC:ABC	2
116	PAOZZA	5310-01-478-6341	30554	88-20033-11B	WASHER,FLAT..... UOC:FPB,ABC,LTG	3
117	PAOZZA	5305-00-417-4955	98897	LS12906-87	SCREW,MACHINE..... UOC:FPB,ABC,LTG	1
117	PAOZZA	5305-01-500-7231	29381	1424011A	SCREW,MACHINE..... UOC:FPA	1
117B	PAOZZA	5305-01-479-1180	97403	13230E6674-64A	SCREW,MACHINE..... UOC:FPA	3
118	PAOOOA	2990-01-478-5699	97403	13230E6251	CONTROL UNIT,GOVERN SEE FIGURE C-23 FOR BREAKDOWN..... UOC:FPB,FPA,ABC,LTG	1
118B	PAOZZA	5975-01-244-6418	97403	13226E8549	CLAMP,COUPLING NUT..... UOC:ABC	1
119	XBOZZA		97403	13230E6268	.COVER, TOP..... UOC:FPB,FPA,ABC,LTG	1
119A	XBFZZA		97403	13230E6219	PLATE,WIRING DIAGRA..... UOC:LTG	1
119B	PAHZZA	5320-00-932-1972	97403	13214E3789-2	RIVET,BLIND..... UOC:LTG	10
119C	XBOZZA		97403	13230E6969	PLATE,WIRING DIAGRA..... UOC:ABC	1
120	XBFZZA		97403	13230E6272	PLUG,PROTECTIVE..... UOC:FPB,ABC,LTG	1
120A	PAOZZA	5305-01-500-6912	29381	1434011A	SCREW,MACHINE..... UOC:FPA	9
121	XBOZZA		97403	13230E6269	COVER,REGULATOR BOX..... UOC:FPB,ABC,LTG	1
121	XBOZZA		29381	4210040B	COVER,REGULATOR BOX..... UOC:FPA	1
121A	PAFZZA	5325-01-500-5761	29381	1224201A	INSERT,FASTNER..... UOC:FPA	4

Section II.

ARMY TM 9-6115-670-14&P

(1) Item No	(2) SMR CODE	(3) NSN	(4) CAGEC	(5) Part Number	(6) Description and Usable on Code (UOC)	(7) QTY
GROUP 1 GENERATOR 10KW,APU						
FIG C-2						
122	XBFFFA		97403	13230E6260	WIRING HARNESS,P1 SEE FIGURE C-21 FOR BREAKDOWN.....	1
					UOC:LTG,FPB	
122	MOOOOA		97403	13230E6975	HARNESS,WIRING,P1 SEE FIGURE C-21 FOR BREAKDOWN.....	1
					UOC:ABC	
122	XBFFFA		29381	2233006E	HARNESS,WIRING P1 SEE FIGURE C-21 FOR BREAKDOWN.....	1
					UOC:FPA	
122A	PAOZZA	5306-01-500-5928	29381	1143006A	BOLT,MACHINE.....	3
					UOC:FPA	
122B	MOOOOA		97403	13230E6979	.CAPACITOR ASSEMBLY.....	1
					UOC:ABC	
122C	PAFZZA		97403	13230E6978	. .CAPACITOR, FIXED, ELE.....	1
					UOC:ABC	
122D	PAOZZA	5940-00-143-4771	97403	13226E0107-5	. . TERMINAL, LUG.....	1
					UOC:ABC	
122E	PAOZZA	5940-00-113-8184	96906	MS25036-150	. . TERMINAL, LUG.....	1
					UOC:ABC	
123	XBHZZA		97403	13230E6332	ADAPTER, FLYWHEEL.....	1
					UOC:FPB,ABC,LTG	
123	XBHZZA		29381	4130026B	ADAPTER, FLYWHEEL.....	1
					UOC:FPA	
123A	PAOZZA	5305-01-479-1176	97403	13230E6674-99A	SCREW,MACHINE.....	1
					UOC:LTG	
123B	PAOZZA	5340-01-500-5801	30554	88-20546-8	CLAMP, LOOP.....	1
					UOC:LTG	
123C	PAOZZA	5310-00-250-9477	97403	13218E0320-291	NUT, PLAIN, HEXAGON.....	1
					UOC:LTG	
123D	PAOZZA	5365-01-500-4915	97403	13230E6881-1	SPACER, RING.....	2
					UOC:LTG	
123E	PAOZZA	5365-01-500-4921	97403	13230E6881-2	SPACER, RING.....	2
					UOC:LTG	
123F	PAOZZA	5305-00-782-9489	80204	B1821BH038C200N	SCREW,CAP, HEXAGON H.....	2
					UOC:LTG	
123G	PAOZZA	5305-00-543-2866	80204	B1821BH038C250N	SCREW,CAP, HEXAGON H.....	2
					UOC:LTG	
124	PAOZZA	5307-01-500-4874	29381	1453041A	STUD, SHOULDERED.....	4
					UOC:FPA	
124A	PAOZZA	5310-01-500-6085	29381	1321008A	WASHER, LOCK.....	10
					UOC:FPA	
124B	PAOZZA	5310-01-500-5957	29381	1211009A	NUT, PLAIN, HEXAGON.....	4
					UOC:FPA	
125	PAOZZA	5310-01-478-5703	97403	13230E6744-46	WASHER, LOCK.....	14
					UOC:ABC,FPB	
126	PAOZZA	5305-01-140-9118	80204	B1821BH038C088N	SCREW,CAP, HEXAGON H.....	8
					UOC:FPB,ABC,LTG	
126	PAHZZA	5306-01-500-2740	29381	1143002A	BOLT, MACHINE.....	5
					UOC:FPA	
127	PAOZZA	5305-00-543-4372	80204	B1821BH038C075N	SCREW,CAP, HEXAGON H.....	6
					UOC:FPB,FPA,ABC,LTG	
128	XBOZZA		97403	13230E6270	COVER, RELAY.....	1
					UOC:LTG,FPB	
128	XBOZZA		29381	4210039A	COVER, RELAY.....	1
					UOC:FPA	
128	XBOZZA		97403	13230E6965	COVER, RELAY BOARD.....	1
					UOC:ABC	

Section II.

ARMY TM 9-6115-670-14&P

(1) Item No	(2) SMR CODE	(3) NSN	(4) CAGEC	(5) Part Number	(6) Description and Usable on Code (UOC)	(7) QTY
GROUP 1 GENERATOR 10KW,APU						
FIG C-2						
129	XBOZZA		97403	13230E6312	AIR DEFLECTOR..... UOC:ABC,FPB	2
129	XBOZZA		29381	4210021C	AIR DEFLECTOR..... UOC:FPA	2
129	XBOZZA		97403	13230E6868	AIR DEFLECTOR..... UOC:LTG	2
130	PAOZZA	6110-01-485-9791	97403	13230E6254	CONTACTOR,MAGNETIC..... UOC:FPB,FPA,ABC,LTG	1
131	PAOZZA	5961-00-465-4405	10001	67A7A5-1	SEMICONDUCTOR DEVIC..... UOC:FPB,FPA,ABC,LTG	1
132	PAOZZA	5925-01-478-5111	97403	13230E6253	CIRCUIT BREAKER..... UOC:FPB,FPA,ABC,LTG	1
133	PAOZZA	5950-01-247-3048	59138	5SFT-251	TRANSFORMER,CURRENT..... UOC:FPB,FPA,ABC,LTG	1
134	XBOZZA		97403	13230E6262	PLATE,CONTACTOR..... UOC:FPB,ABC,LTG	1
134	XBFZZA		29381	4210073A	PLATE,CONTACTOR MTG..... UOC:FPA	1
135	PAFZZA	5342-01-478-7932	97403	13230E6274-1	MOUNT,RESILIENT..... UOC:ABC,FPB	10
136	PAOZZA	5310-00-696-5173	30554	69-561-5	NUT,PLAIN,ASSEMBLED..... UOC:FPB,FPA,ABC,LTG	20
137	PAOZZA	5310-01-478-6511	30554	88-21674-4	NUT,PLAIN,CLINCH..... UOC:FPB,ABC,LTG	10
138	XBOZZA		97403	13230E6267	.HOUSING,REAR..... UOC:FPB,ABC,LTG	1
138	XBOZZA		29381	4210013D	HOUSING,REAR..... UOC:FPA	1
139	PAOZZA	5310-01-478-8451	97403	13218E0320-333	NUT,PLAIN,HEXAGON..... UOC:FPB,FPA,ABC,LTG	14
140	XDOZZA		96906	MS35333-110	WASHER,LOCK..... UOC:FPB,FPA,ABC,LTG	2
141	PAOZZA	5310-01-478-6342	30554	88-20033-33B	WASHER,FLAT..... UOC:FPB,FPA,ABC,LTG	13
141A	PAOZZA	5310-01-500-2439	97403	13230E6744-103	WASHER,LOCK..... UOC:LTG,FPB	12
141B	PAOZZA	5310-01-478-5703	97403	13230E6744-46	WASHER,LOCK..... UOC:ABC	12
142	XBFZZA		97403	13230E6275	JUMPER,STRAP..... UOC:FPB,FPA,ABC,LTG	2
143	PAFZAA	5940-01-478-5485	97403	13230E6256	TERMINAL BOARD..... UOC:LTG,FPB,ABC	1
143	PAFZZA	5940-01-500-6581	29381	2173002B	TERMINAL BOARD..... UOC:FPA	1
144	PAOZZA	5307-01-486-0464	97403	13230E6276	STUD,CONTINUOUS THR..... UOC:FPB,FPA,ABC,LTG	4
144A	PAOZZA	5310-01-500-6120	29381	1224001A	NUT,PLAIN,WING..... UOC:FPA	2
144B	XBFZZA		29381	4140013A	STRIP,STUD..... UOC:FPA	1
144C	PAHZZA	5320-01-015-6896	81349	M24243/1-B404	RIVET,BLIND..... UOC:FPA	2
145	XBFZZA		97403	13230E6266	HOUSING,FRONT..... UOC:LTG,FPB	1
145	XBFZZA		29381	4210014D	HOUSING,FRONT..... UOC:FPA	1

Section II.

ARMY TM 9-6115-670-14&P

(1) Item No	(2) SMR CODE	(3) NSN	(4) CAGEC	(5) Part Number	(6) Description and Usable on Code (UOC)	(7) QTY
GROUP 1 GENERATOR 10KW,APU						
FIG C-2						
145	XBOZZ		97403	13230E6977	HOUSING,FRONT..... UOC:ABC	1
146	PAFZZA	5340-01-486-5978	97403	13230E6263	PLATE,MOUNTING..... UOC:LTG,FPB	1
146	PAFZZA	5975-01-500-6573	29381	4210038E	PANEL,BLANK..... UOC:FPA	1
146	XBOZZA		97403	13230E6971	PLATE,CONTACTOR..... UOC:ABC	1
147	PAOZZA	5305-01-479-1844	97403	13218E0493-349PI IC	SCREW,MACHINE..... UOC:FPB,ABC,LTG	2
147	PAOZZA	5305-01-500-2315	97403	13218E0493-350PI IC	SCREW,MACHINE..... UOC:FPA	2
148	PAOZZA	5305-01-479-1842	97403	13218E0493-354PI IC	SCREW,MACHINE..... UOC:FPB,ABC,LTG	4
148	PAOZZA	5305-01-500-6554	29381	1454007A	SCREW,CAP,HEAD..... UOC:FPA	4
149	PAOZZA	5305-01-479-1841	97403	13218E0493-345PI IC	SCREW,MACHINE..... UOC:FPB,ABC,LTG	2
149	PAOZZA	5305-01-500-5980	29381	1423005A	SCREW,MACHINE..... UOC:FPA	4
150	PAOZZA	5310-01-478-5700	97403	13230E6744-59	WASHER,FLAT..... UOC:FPB,ABC,LTG	8
151	PAOZZA	5310-00-934-9739	96906	MS35649-242	NUT,PLAIN,HEXAGON..... UOC:FPB,ABC,LTG	8
151	PAOZZA	5310-01-500-6179	29381	1224017A	NUT,SELF-LOCKING,AS..... UOC:FPA	4
152	XBFZZA		97403	13230E6265	BOX,REGULATOR..... UOC:LTG,FPB	1
152	XBFZZA		29381	4210036C	BOX,REGULATOR LEFT..... UOC:FPA	1
152	XBOZZA		97403	13230E6964	BOX,REGULATOR LEFT..... UOC:ABC	1
153	PAFZZA	5945-01-382-8925	77342	VF4-15H11-S05	RELAY,ELECTROMAGNET..... UOC:LTG,FPB,FPA,ABC	1
154	PAFZZA	5935-01-208-3507	53867	3-334-485-008	SOCKET,PLUG-IN ELEC..... UOC:FPB,FPA,ABC,LTG	3
155	PAOZZA	5310-00-052-3632	30554	69-561-3	NUT,PLAIN,ASSEMBLED..... UOC:FPB,ABC,LTG	8
155	PAOZZA	5310-01-500-6181	29381	1224015A	NUT,SELF-LOCKING,AS..... UOC:FPA	8
155A	XBFZZA		97403	13230E6231-4	TERMINAL,QUICK DISC..... UOC:FPB,FPA,ABC,LTG	2
155B	PAOZZA	5910-01-481-3023	59660	4206-006	CAPACITOR,AIRCRAFT..... UOC:ABC	2
156	PAFZZA	5325-00-276-6343	96906	MS35489-23	GROMMET,NONMETALLIC..... UOC:FPB,FPA,ABC,LTG	3
157	PAOZZA	5310-01-478-9268	97403	13218E0320-248	NUT,PLAIN,HEXAGON..... UOC:FPB,ABC,LTG	4
157	PAOZZA	5310-01-500-6179	29381	1224017A	NUT,SELF-LOCKING,AS..... UOC:FPA	4
158	PAFZZA	6110-01-478-6439	97403	13230E6252	REGULATOR,VOLTAGE..... UOC:FPB,FPA,ABC,LTG	1
159	PAOZZA	5999-01-499-7691	97403	13230E6249	STRIP,ELECTRICAL GR..... UOC:FPB,FPA,ABC,LTG	1
160	XBOZZA		97403	13230E6248	SHUNT,DC..... UOC:FPB,FPA,ABC,LTG	1
161	PAOZZA	5305-01-479-1212	97403	13230E6671-365A	SCREW,MACHINE..... UOC:LTG,FPB,FPA,ABC	1

Section II.

ARMY TM 9-6115-670-14&P

(1) Item No	(2) SMR CODE	(3) NSN	(4) CAGEC	(5) Part Number	(6) Description and Usable on Code (UOC)	(7) QTY
GROUP 1 GENERATOR 10KW,APU						
FIG C-2						
162	PAFFAA	6150-01-479-0594	97403	13230E6258	WIRING HARNESS SEE FIGURE C-22 FOR BREAKDOWN..... UOC:LTG,FPB	1
162	XBFFFA		29381	2233004E	HARNESS,WIRING J1 SEE FIGURE C-22 FOR BREAKDOWN..... UOC:FPA	1
162A	MOOZZA		97403	13230E6961	WIRING HARNESS SEE FIGURE C-22 FOR BREAKDOWN..... UOC:ABC	1
162B	MOOZZA		97403	13230E6962	WIRING HARNESS SEE FIGURE C-22 FOR BREAKDOWN..... UOC:ABC	1
163	PAOZZA	5305-01-479-1839	97403	13218E0493-289PI IC	SCREW,MACHINE..... UOC:FPB,ABC,LTG	8
163	PAOZZA	5305-01-500-6554	29381	1454007A	SCREW,CAP,HEAD..... UOC:FPA	4
164	PAFHHA	6115-01-484-6250	97403	13230E6302	GENERATOR,ALTERNATI SEE FIGURE C-24 FOR BREAKDOWN..... UOC:FPB,FPA,ABC,LTG	1
165	XBFFFA		97403	13230E6261	WIRING HARNESS,J3.....	1
165	XBFFFA		97403	13230E6261	WIRING HARNESS,J3 SEE FIGURE C-20 FOR BREAKDOWN..... UOC:FPB,ABC,LTG	1
165	XBFFFA		29381	2233005E	HARNESS,WIRING J3 SEE FIGURE C-20 FOR BREAKDOWN..... UOC:FPA	1
166	XBFZZA		97403	13230E6264	BOX,DC..... UOC:LTG,FPB	1
166	XBFZZA		29381	4210037B	BOX,DC RIGHT..... UOC:FPA	1
166	XBOZZA		97403	13230E6968	BOX,DC,RIGHT..... UOC:ABC	1
166A	PAFZZA	5340-01-500-6126	97403	13230E6812-1	MOUNT,RESILIENT,GEN..... UOC:FPB,ABC,LTG	6
167	PAFZZA	5945-01-479-0301	97403	13230E6279	RELAY ASSEMBLY..... UOC:FPB,FPA,ABC,LTG	1
168	MFFZZA		97403	13230E6232-16	LEAD,ELECTRICAL..... UOC:FPB,FPA,ABC,LTG	1
168A	MFFZZA		97403	13230E6232-34	LEAD,ELECTRICAL..... UOC:FPB,ABC,LTG	1
168B	MFFZZA		97403	13230E6232-35	LEAD,ELECTRICAL..... UOC:FPB,ABC,LTG	1
168C	MFFZZA		97403	13230E6232-36	LEAD,ELECTRICAL..... UOC:FPB,ABC,LTG	1
169	MFFZZA		97403	13230E6653-4-14I NCH	WIRE,ELECTRICAL MAKE FROM WIRE,ELECTRICAL (97403)13230E6653-4;14 IN S..... UOC:FPB,FPA,ABC,LTG	1
169A	MFFZZA		97403	13230E6653-8-2.5 INCH	WIRE,ELECTRICAL MAKE FROM WIRE,ELECTRICAL (97403)13230E6653-8;2.5 I ES..... UOC:FPB,ABC,LTG	1
169B	MFFZZA		97403	13230E6653-8-2.5 INCH	WIRE,ELECTRICAL MAKE FROM WIRE,ELECTRICAL (97403)13230E6653-8;2.5 I ES..... UOC:FPB,ABC,LTG	1

Section II.

ARMY TM 9-6115-670-14&P

(1) Item No	(2) SMR CODE	(3) NSN	(4) CAGEC	(5) Part Number	(6) Description and Usable on Code (UOC)	(7) QTY
GROUP 1 GENERATOR 10KW,APU						
FIG C-2						
169C	MFFZZA		97403	13230E6653-8-2.5 INCH	WIRE,ELECTRICAL MAKE FROM WIRE,ELECTRICAL (97403)13230E6653-8;2.5 I ES..... UOC:FPB,ABC,LTG	1
170	MFFZZA		97403	13230E6232-19	LEAD,ELECTRICAL..... UOC:FPB,FPA,ABC,LTG	1
171	MFFZZA		97403	13230E6653-8-6.5 INCH	WIRE,ELECTRICAL MAKE FROM WIRE,ELECTRICAL (97403)13230E6653-8;6.5 I ES..... UOC:FPB,FPA,ABC,LTG	1
172	PAFZZA	5940-00-113-9826	96906	MS25036-114	TERMINAL,LUG..... UOC:FPB,FPA,ABC,LTG	1
173	MFFZZA		97403	13230E6232-20	LEAD,ELECTRICAL..... UOC:FPB,FPA,ABC,LTG	1
174	MFFZZA		97403	13230E6653-8-7.2 5INCH	WIRE,ELECTRICAL MAKE FROM WIRE,ELECTRICAL (97403)13230E6653-8;7.25 HES..... UOC:FPB,FPA,ABC,LTG	1
175	PAFZZA	5940-00-113-9826	96906	MS25036-114	TERMINAL,LUG..... UOC:FPB,FPA,ABC,LTG	1
176	MFFZZA		97403	13230E6232-17	LEAD,ELECTRICAL..... UOC:FPB,FPA,ABC,LTG	1
177	PAFZZA	5940-00-113-9826	96906	MS25036-114	TERMINAL,LUG..... UOC:FPB,FPA,ABC,LTG	1
178	MFFZZA		97403	13230E6653-8-28I NCH	WIRE,ELECTRICAL MAKE FROM WIRE,ELECTRICAL (97403)13230E6653-8;28 IN S..... UOC:FPB,FPA,ABC,LTG	1
179	MFFZZA		29381	2231038C	LEAD,ELECTRICAL..... UOC:FPA	1
180	PAFZZA	5940-00-113-8183	96906	MS25036-113	TERMINAL,LUG..... UOC:FPA	1
181	MFFZZA		97403	13230E6653-8-28I NCH	WIRE,ELECTRICAL MAKE FROM WIRE,ELECTRICAL (97403)13230E6653-8;28 IN S..... UOC:FPA	1
182	PAFZZA	5940-00-113-9826	96906	MS25036-114	TERMINAL,LUG..... UOC:FPA	1
183	MFFZZA		29381	2231039D	LEAD,ELECTRICAL..... UOC:FPA	1
184	PAFZZA	5940-01-503-8272	29381	2111001A	TERMINAL,LUG..... UOC:FPA	1
185	MFFZZA		97403	13230E6653-8-28I NCH	WIRE,ELECTRICAL MAKE FROM WIRE,ELECTRICAL (97403)13230E6653-8;28 IN S..... UOC:FPA	1
186	PAFZZA	5940-00-113-8183	96906	MS25036-113	TERMINAL,LUG..... UOC:FPA	1
187	MFFZZA		97403	13230E6259	LEAD,ELECTRICAL..... UOC:FPB,FPA,ABC,LTG	1
188	PAFZZA	5940-01-478-6050	97403	13230E6236-2	TERMINAL,QUICK DISC..... UOC:FPB,FPA,ABC,LTG	1
189	PAFZZA	5940-01-027-4669	56501	A-250	TERMINAL,QUICK DISC..... UOC:FPB,FPA,ABC,LTG	1
190	MFFZZA		97403	13230E6653-4-24I NCH	WIRE,ELECTRICAL MAKE FROM WIRE,ELECTRICAL (97403)13230E6653-4;24 IN S..... UOC:FPB,FPA,ABC,LTG	1

Section II.

ARMY TM 9-6115-670-14&P

(1) Item No	(2) SMR CODE	(3) NSN	(4) CAGEC	(5) Part Number	(6) Description and Usable on Code (UOC)	(7) QTY
GROUP 1 GENERATOR 10KW,APU						
FIG C-2						
191	PAFZZA	5940-00-143-4771	96906	MS25036-103	TERMINAL,LUG..... UOC:FPB,FPA,ABC,LTG	1
192	MFFZZA		97403	13230E6232-15	LEAD,ELECTRICAL..... UOC:FPB,FPA,ABC,LTG	1
193	PAFZZA	5940-01-027-4669	56501	A-250	TERMINAL,QUICK DISC..... UOC:FPB,FPA,ABC,LTG	2
194	MFFZZA		97403	13230E6653-4-4.5 INCH	WIRE,ELECTRICAL MAKE FROM WIRE,ELECTRICAL (97403)13230E6653-4;4.5 I ES..... UOC:FPB,FPA,ABC,LTG	1
195	MFFZZA		97403	13230E6232-21	LEAD,ELECTRICAL..... UOC:FPB,FPA,ABC,LTG	1
196	PAFZZA	5940-00-113-9826	96906	MS25036-114	TERMINAL,LUG..... UOC:FPB,FPA,ABC,LTG	1
197	MFFZZA		97403	13230E6653-7-10I NCH	WIRE,ELECTRICAL MAKE FROM WIRE,ELECTRICAL (97403)13230E6653-7;10 IN S..... UOC:FPB,FPA,ABC,LTG	1
198	PAFZZA	5940-01-264-6657	81495	442 6474	TERMINAL,QUICK DISC..... UOC:FPB,FPA,ABC,LTG	1
199	MFFZZA		97403	13230E6232-18	LEAD,ELECTRICAL..... UOC:FPB,FPA,ABC,LTG	1
200	MFFZZA		97403	13230E6653-7-22I NCH	WIRE,ELECTRICAL MAKE FROM WIRE,ELECTRICAL (97403)13230E6653-7;22 IN S..... UOC:FPB,FPA,ABC,LTG	1
201	PAFZZA	5940-01-264-6657	81495	442 6474	TERMINAL,QUICK DISC..... UOC:FPB,FPA,ABC,LTG	1
202	MFFZZA		97403	13230E6232-22	LEAD,ELECTRICAL..... UOC:FPB,ABC,LTG	1
203	PAFZZA	5940-00-113-9826	96906	MS25036-114	TERMINAL,LUG..... UOC:FPB,ABC,LTG	1
204	MFFZZA		97403	13230E6653-8-15I NCH	WIRE,ELECTRICAL MAKE FROM WIRE,ELECTRICAL (97403)13230E6653-8;15 IN S..... UOC:FPB,ABC,LTG	1
205	PAFZZA	5940-00-113-8183	96906	MS25036-113	TERMINAL,LUG..... UOC:FPB,ABC,LTG	1
206	MFFZZA		97403	13230E6232-23	LEAD,ELECTRICAL..... UOC:FPB,ABC,LTG	1
207	PAFZZA	5940-00-113-9826	96906	MS25036-114	TERMINAL,LUG..... UOC:FPB,ABC,LTG	1
208	MFFZZA		97403	13230E6653-7-14I NCH	WIRE,ELECTRICAL MAKE FROM WIRE,ELECTRICAL (97403)13230E6653-7;14 IN S..... UOC:FPB,ABC,LTG	1
209	PAFZZA	5940-00-143-4794	96906	MS25036-112	TERMINAL,LUG..... UOC:FPB,ABC,LTG	1
210	MFFZZA		97403	13230E6232-28	LEAD,ELECTRICAL..... UOC:FPB,FPA,ABC,LTG	1
211	PAFZZA	5940-01-052-7646	14726	S05300F	TERMINAL,QUICK DISC..... UOC:FPB,FPA,ABC,LTG	1
212	MFFZZA		97403	13230E6653-4-17I NCH	WIRE,ELECTRICAL MAKE FROM WIRE,ELECTRICAL (97403)13230E6653-4;17 IN S..... UOC:FPB,FPA,ABC,LTG	1
213	MFFZZA		97403	13230E6232-29	LEAD,ELECTRICAL..... UOC:FPB,FPA,ABC,LTG	1

Section II.

ARMY TM 9-6115-670-14&P

(1) Item No	(2) SMR CODE	(3) NSN	(4) CAGEC	(5) Part Number	(6) Description and Usable on Code (UOC)	(7) QTY
GROUP 1 GENERATOR 10KW,APU						
FIG C-2						
214	PAFZZA	5940-01-052-7646	14726	S05300F	TERMINAL,QUICK DISC..... UOC:FPB,FPA,ABC,LTG	1
215	MFFZZA		97403	13230E6653-4-24I NCH	WIRE,ELECTRICAL MAKE FROM WIRE,ELECTRICAL (97403)13230E6653-4;24 IN S..... UOC:FPB,FPA,ABC,LTG	1
216	PAFZZA	5940-00-143-4773	97403	13217E3854-5	TERMINAL,LUG..... UOC:FPB,FPA,ABC,LTG	1
217	MFFZZA		97403	13230E6232-24	LEAD,ELECTRICAL..... UOC:FPB,FPA,ABC,LTG	1
218	PAFZZA	5940-01-264-6657	81495	442 6474	TERMINAL,QUICK DISC..... UOC:FPB,FPA,ABC,LTG	1
219	MFFZZA		97403	13230E6653-7-24I NCH	WIRE,ELECTRICAL MAKE FROM WIRE,ELECTRICAL (97403)13230E6653-7-24;24 CHES..... UOC:FPB,FPA,ABC,LTG	1
220	PAFZZA	5940-00-113-9826	96906	MS25036-114	TERMINAL,LUG..... UOC:FPB,FPA,ABC,LTG	1
221	MFFZZA		97403	13230E6232-33	LEAD,ELECTRICAL..... UOC:FPB,FPA,ABC,LTG	1
222	PAFZZA	5940-00-143-4771	96906	MS25036-103	TERMINAL,LUG..... UOC:FPB,FPA,ABC,LTG	1
223	MFFZZA		97403	13230E6653-4-46I NCH	WIRE,ELECTRICAL MAKE FROM WIRE,ELECTRICAL (97403)13230E6653-4;46 IN S..... UOC:FPB,FPA,ABC,LTG	1
224	PAFZZA	5940-01-052-7646	14726	S05300F	TERMINAL,QUICK DISC..... UOC:FPB,FPA,ABC,LTG	1
225	MFFZZA		97403	13230E6232-30	LEAD,ELECTRICAL..... UOC:LTG,FPB,FPA,ABC	1
226	PAFZZA	5940-00-143-4773	97403	13217E3854-5	TERMINAL,LUG..... UOC:FPB,FPA,ABC,LTG	1
227	MFFZZA		97403	13230E6653-4-30I NCH	WIRE,ELECTRICAL MAKE FROM WIRE,ELECTRICAL (97403) 13230E6653-4;30 I ES..... UOC:FPB,FPA,ABC,LTG	1
228	PAFZZA	5940-01-052-7646	14726	S05300F	TERMINAL,QUICK DISC..... UOC:FPB,FPA,ABC,LTG	1
229	MFFZZA		97403	13230E6232-31	LEAD,ELECTRICAL..... UOC:FPB,FPA,ABC,LTG	1
230	PAFZZA	5940-00-143-4773	97403	13217E3854-5	TERMINAL,LUG..... UOC:FPB,FPA,ABC,LTG	1
231	MFFZZA		97403	13230E6653-4-30. 5INCH	WIRE,ELECTRICAL MAKE FROM WIRE,ELECTRICAL (97403)13230E6653-4;30.5 HES..... UOC:FPB,FPA,ABC,LTG	1
232	PAFZZA	5940-01-052-7646	14726	S05300F	TERMINAL,QUICK DISC..... UOC:FPB,FPA,ABC,LTG	1
233	MFFZZA		97403	13230E6232-26	LEAD,ELECTRICAL..... UOC:FPB,FPA,ABC,LTG	1
234	PAFZZA	5940-01-052-7646	14726	S05300F	TERMINAL,QUICK DISC..... UOC:FPB,FPA,ABC,LTG	1
235	MFFZZA		97403	13230E6653-4-26. 62INCH	WIRE,ELECTRICAL MAKE FROM WIRE,ELECTRICAL (97403)13230E6653-4;26.62 CHES..... UOC:FPB,FPA,ABC,LTG	1

Section II.

ARMY TM 9-6115-670-14&P

(1) Item No	(2) SMR CODE	(3) NSN	(4) CAGEC	(5) Part Number	(6) Description and Usable on Code (UOC)	(7) QTY
					GROUP 1 GENERATOR 10KW,APU	
					FIG C-2	
236	PAFZZA	5940-01-027-4669	56501	A-250	TERMINAL,QUICK DISC..... UOC:FPA,FPA,ABC,LTG	1
237	MFFZZA		97403	13230E6232-27	LEAD,ELECTRICAL..... UOC:FPA,FPA,ABC,LTG	1
238	PAFZZA	5940-01-052-7646	14726	S05300F	TERMINAL,QUICK DISC..... UOC:FPA,FPA,ABC,LTG	1
239	MFFZZA		97403	13230E6653-4-18.5 INCH	WIRE,ELECTRICAL MAKE FROM WIRE,ELECTRICAL (97403)13230E6653-4;18.5 HES..... UOC:FPA,FPA,ABC,LTG	1
240	MFFZZA		97403	13230E6232-37ZZ	LEAD,ELECTRICAL..... UOC:FPA,ABC,LTG	1
241	PAFZZA	5940-01-052-7646	14726	S05300F	TERMINAL,QUICK DISC..... UOC:FPA,ABC,LTG	2
242	MFFZZA		97403	13230E6653-4-3IN CH	WIRE,ELECTRICAL MAKE FROM WIRE,ELECTRICAL (97403)13230E6653-4;3 INCH..... UOC:FPA,ABC,LTG	1
243	MFFZZA		29381	2231023B	LEAD,ELECTRICAL..... UOC:FPA	1
244	PAFZZA	5940-01-264-6657	81495	442 6474	TERMINAL,QUICK DISC..... UOC:FPA	1
245	MFFZZA		97403	13230E6653-7-29I NCH	WIRE,ELECTRICAL MAKE FROM WIRE,ELECTRICAL (97403)13230E6653-7;29 IN S..... UOC:FPA	1
246	PAOZZA	5970-01-500-6528	29381	2219027A	INSULATION SLEEVING..... UOC:FPA	2
247	PAFZZA	5940-00-113-9826	96906	MS25036-114	TERMINAL,LUG..... UOC:FPA	1
248	MFFZZA		97403	13230E6232-32	LEAD,ELECTRICAL..... UOC:FPA,FPA,ABC,LTG	1
249	PAFZZA	5940-00-143-4771	96906	MS25036-103	TERMINAL,LUG..... UOC:FPA,FPA,ABC,LTG	1
250	MFFZZA		97403	13230E6653-4-26.5 INCH	WIRE,ELECTRICAL MAKE FROM WIRE,ELECTRICAL (97403)13230E6653-4;26.5 HES..... UOC:FPA,FPA,ABC,LTG	1
251	PAFZZA	5940-01-052-7646	14726	S05300F	TERMINAL,QUICK DISC..... UOC:FPA,FPA,ABC,LTG	1
252	MFFZZA		97403	13230E6232-25	LEAD,ELECTRICAL..... UOC:FPA,ABC,LTG	1
253	PAFZZA	5940-01-052-7646	14726	S05300F	TERMINAL,QUICK DISC..... UOC:FPA,ABC,LTG	1
254	MFFZZA		97403	13230E6653-4-28I NCH	WIRE,ELECTRICAL MAKE FROM WIRE,ELECTRICAL (97403)13230E6653-4;28 IN S..... UOC:FPA,ABC,LTG	1
255	PAFZZA	5940-01-027-4669	56501	A-250	TERMINAL,QUICK DISC..... UOC:FPA,ABC,LTG	1
256	MFFZZA		29381	2231013D	LEAD,ELECTRICAL..... UOC:FPA	1
257	PAFZZA	5940-01-052-7646	14726	S05300F	TERMINAL,QUICK DISC..... UOC:FPA	1
258	MFFZZA		97403	13230E6653-4-32I NCH	WIRE,ELECTRICAL MAKE FROM WIRE,ELECTRICAL (97403)13230E6653-4;32 IN S..... UOC:FPA	1

Section II.

ARMY TM 9-6115-670-14&P

(1) Item No	(2) SMR CODE	(3) NSN	(4) CAGEC	(5) Part Number	(6) Description and Usable on Code (UOC)	(7) QTY
					GROUP 1 GENERATOR 10KW,APU	
					FIG C-2	
259	PAFZZA	5940-01-478-6050	97403	13230E6236-2	TERMINAL,QUICK DISC..... UOC:FPA	1
260	MFZZA		29381	2231032A	LEAD,ELECTRICAL..... UOC:FPA	1
261	PAFZZA	5940-01-500-6513	29381	2113003A	TERMINAL,QUICK DISC..... UOC:FPA	2
262	MFZZA		97403	13230E6653-4-2IN CH	WIRE,ELECTRICAL MAKE FROM WIRE,ELECTRICAL (97403)13230E6653-4;22 IN..... UOC:FPA	1

End of Figure

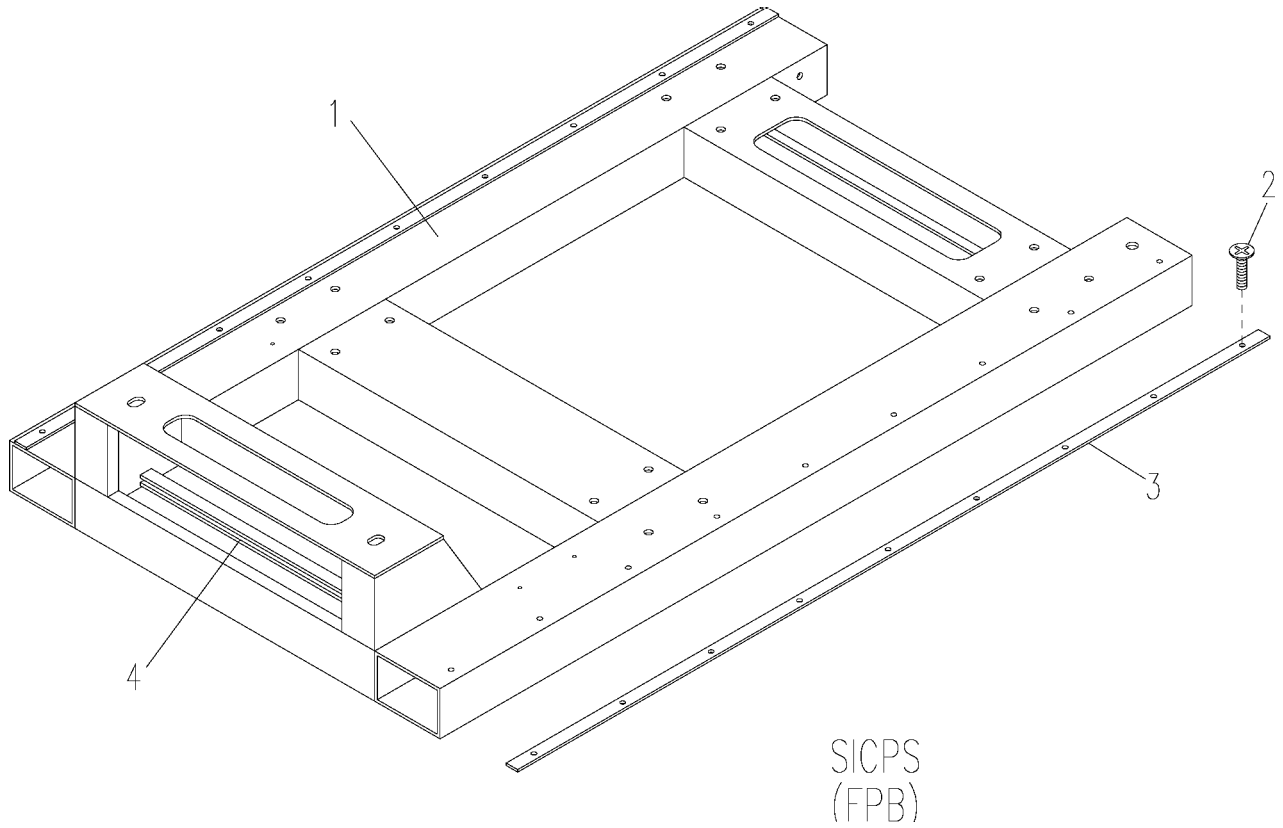

Figure C-3. Frame Assembly, SICPS

Section II.

ARMY TM 9-6115-670-14&P

(1) Item No	(2) SMR CODE	(3) NSN	(4) CAGEC	(5) Part Number	(6) Description and Usable on Code (UOC)	(7) QTY
					GROUP 0101 FRAME ASSEMBLY, SICPS	
					FIG C-3	
1	XBFZZA		97403	13230E6301	..FRAME..... UOC:ABC,FPB	1
2	PAOZZA	5305-01-479-1061	97403	13230E6673-65A	..SCREW,MACHINE..... UOC:ABC,FPB	36
3	XBFZZA		97403	13230E6293	..RUNNER..... UOC:ABC,FPB	4
4	MOOZZA		97403	13230E6292-2-11I NCH	..NONMETALLIC CHANNEL MAKE FROM NONMETALLIC CHANNEL P/N (97403) 13230E629 ; 11 INCHES..... UOC:ABC,FPB	1

End of Figure

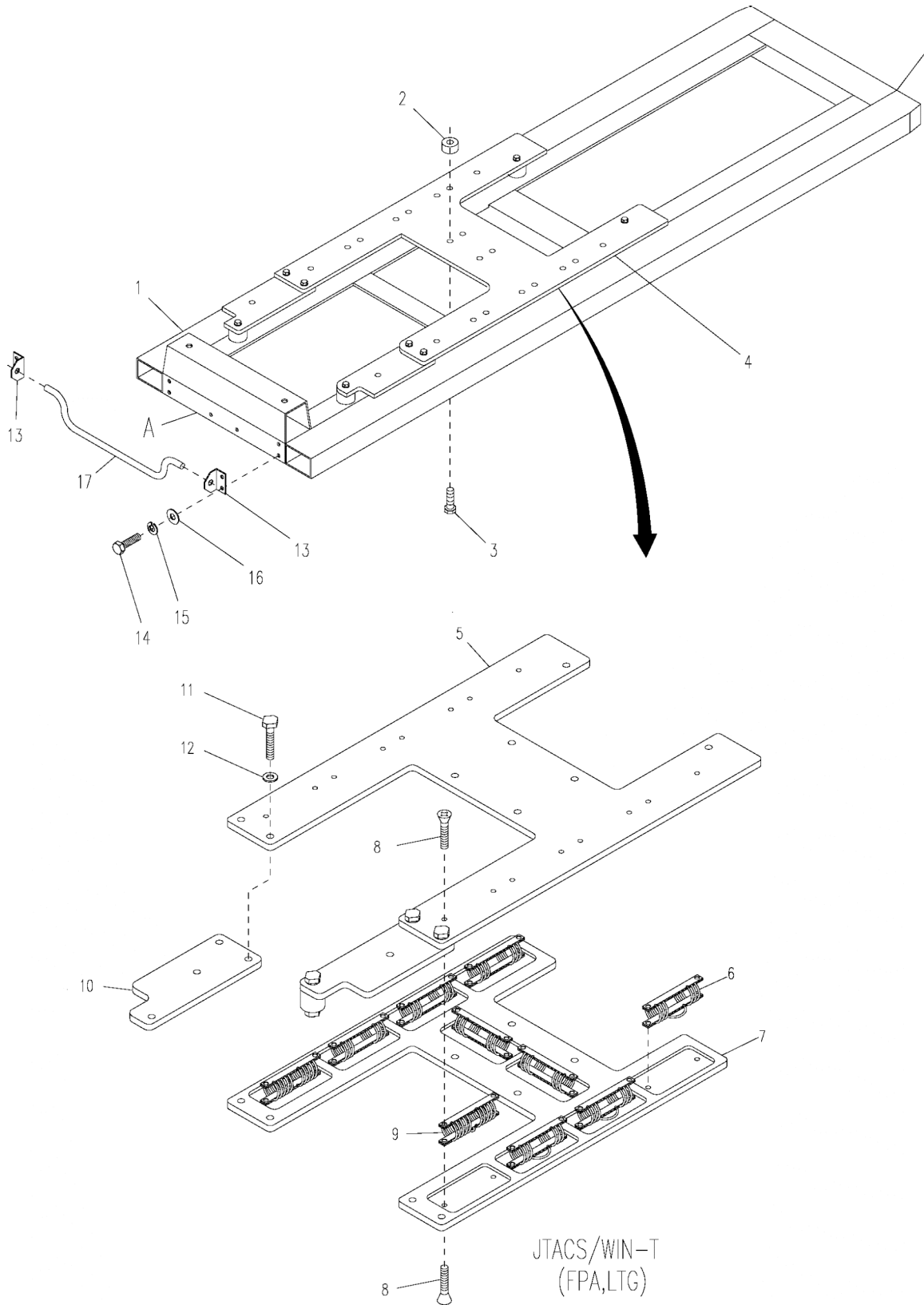
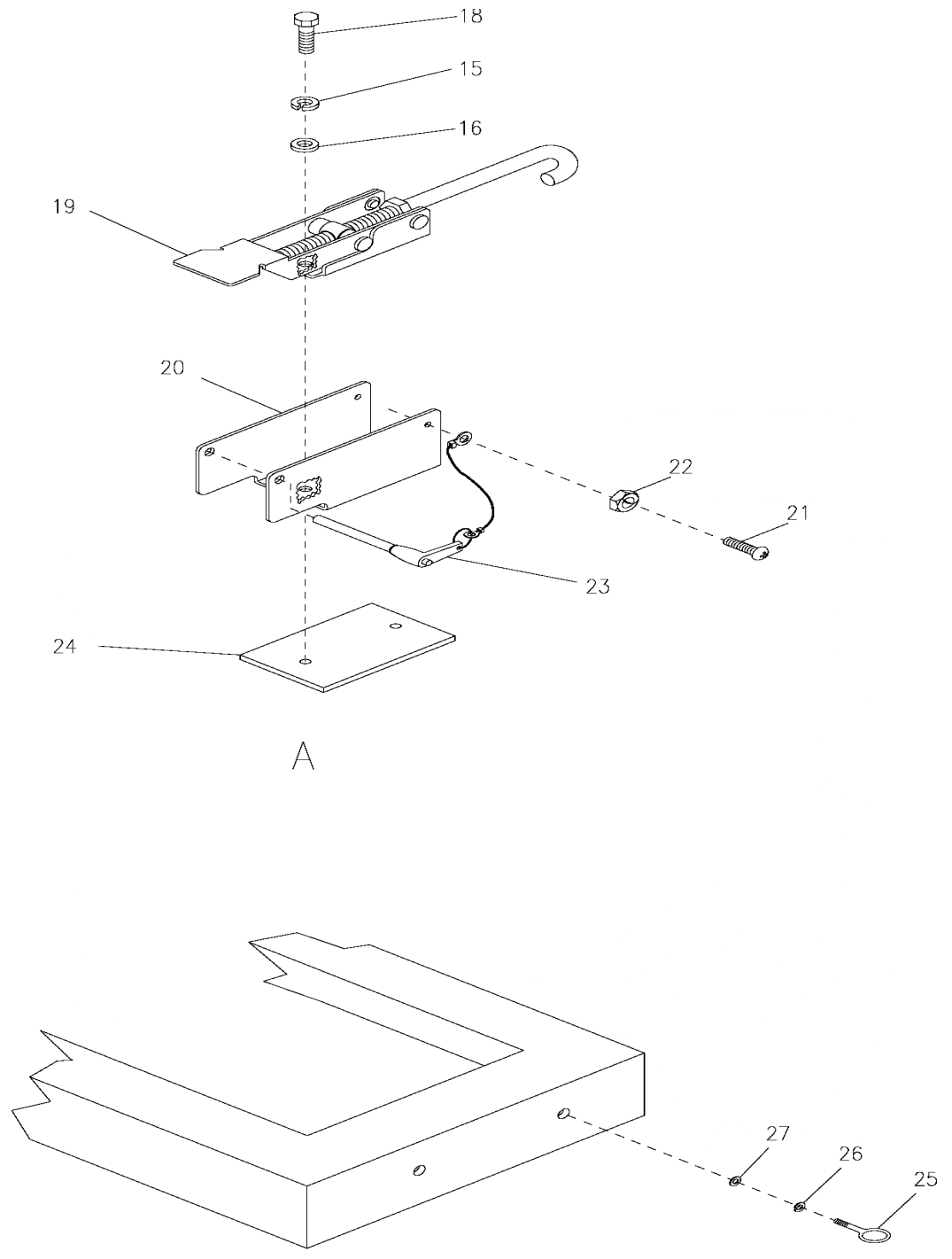

Figure C-4. Frame Assembly, JTACSWIN-T (Sheet 1 of 2)

ARMY TM 9-6115-670-14&P



NOTE

View A rotated 90° CW.

Figure C-4. Frame Assembly, JTACS/WIN-T (Sheet 2 of 2)

Section II.

ARMY TM 9-6115-670-14&P

(1) Item No	(2) SMR CODE	(3) NSN	(4) CAGEC	(5) Part Number	(6) Description and Usable on Code (UOC)	(7) QTY
GROUP 0102 FRAME ASSEMBLY, JTACS/WIN-T						
FIG C-4						
1	XBFZZA		97403	13230E6648	. . FRAME, EXTENDED.	1
					UOC: LTG	
1	XBFZZA		29381	4250078C	FRAME, EXTENDED.	1
					UOC: FPA	
2	PAOZZA	3120-01-500-4911	97403	13230E6875	BUSHING, SLEEVE.	4
					UOC: LTG	
3	PAOZZA	5305-12-126-7056	D8286	DIN912M10X35-8-8	SCREW, CAP, SOCKET HE.	4
					UOC: LTG	
4	XBFFFA		97403	13230E6866	MOUNT ASSY, VIBRATIO.	1
					UOC: FPA, LTG	
5	XBFZZA		97403	13230E6879	PLATE, TOP.	1
					UOC: FPA, LTG	
6	XBFZZA		97403	13230E6883-1	ISOLATOR, HELIC.	8
					UOC: FPA, LTG	
7	XBFZZA		97403	13230E6880	PLATE, BASE.	1
					UOC: FPA, LTG	
8	PAFZZA	5305-01-500-3596	97403	13230E6673-83A	SCREW, MACHINE.	40
					UOC: FPA, LTG	
9	XBFZZA		97403	13230E6883-2	ISOLATOR, HELIC.	2
					UOC: FPA, LTG	
10	XBFZZA		97403	13230E6882	PLATE, COUPLING.	2
					UOC: FPA, LTG	
11	PAFZZA	5306-01-500-4971	81346	B1821BH38C100N	BOLT, MACHINE.	4
					UOC: FPA, LTG	
12	PAFZZA	5310-01-500-2484	30554	88-20033-30C	WASHER, FLAT.	4
					UOC: FPA, LTG	
13	XBFZZA		97403	13230E6646	. . BRACKET, PULL HANDLE.	2
					UOC: LTG	
13	XBFZZA		29381	4210232A	BRACKET, PULL HANDLE.	2
					UOC: FPA	
14	PAOZZA	5305-01-479-1176	97403	13230E6674-99A	. . SCREW, MACHINE.	4
					UOC: LTG	
14	PAOZZA	5306-01-500-6451	29381	1131001A	BOLT, MACHINE.	4
					UOC: FPA	
15	PAOZZA	5310-01-467-6832	97403	13230E6744-44	. . WASHER, LOCK.	6
					UOC: LTG	
15	PAOZZA	5310-01-500-6057	29381	1323006A	WASHER, LOCK.	4
					UOC: FPA	
16	PAOZZA	5310-00-809-4058	96906	MS27183-10	. . WASHER, FLAT.	6
					UOC: LTG	
17	XBFZZA		97403	13230E6647	. . HANDLE, PULL.	1
					UOC: LTG	
17	XBFZZA		29381	4210231A	HANDLE, PULL.	1
					UOC: FPA	
18	PAOZZA	5305-01-479-1196	97403	13230E6674-98A	. . SCREW, MACHINE.	2
					UOC: LTG	
19	XBOZZA		97403	13230E6870	LATCH, DRAW ADJUSTAB.	1
					UOC: LTG	
20	XBOZZA		97403	13230E6871	GUARD, LATCH.	1
					UOC: LTG	
21	PAOZZA	5305-01-500-5247	97403	13218E0493-2765P	SCREW, MACHINE.	1
				IIC	UOC: LTG	
22	PAOZZA	5310-00-208-9255	80205	MS21044C3	NUT, SELF-LOCKING, HE.	1
					UOC: LTG	
23	PAOZZA	5315-01-500-0672	97403	13230E6848	PIN, QUICK RELEASE.	1
					UOC: LTG	

Section II.

ARMY TM 9-6115-670-14&P

(1) Item No	(2) SMR CODE	(3) NSN	(4) CAGEC	(5) Part Number	(6) Description and Usable on Code (UOC)	(7) QTY
GROUP 0102 FRAME ASSEMBLY, JTACS/WIN-T						
FIG C-4						
24	XBOZZA		97403	13230E6869	PLATE,HOOK MOUNT..... UOC:LTG	1
25	XBOZZA		97403	13230E6872	EYEBOLT,SHOULDER..... UOC:FPA,LTG	2
26	PAOZZA	5310-01-478-5703	97403	13230E6744-46	WASHER,LOCK..... UOC:FPA,LTG	2
27	PAOZZA	5310-01-500-6448	30554	88-20033-26C	WASHER,FLAT..... UOC:FPA,LTG	2

End of Figure

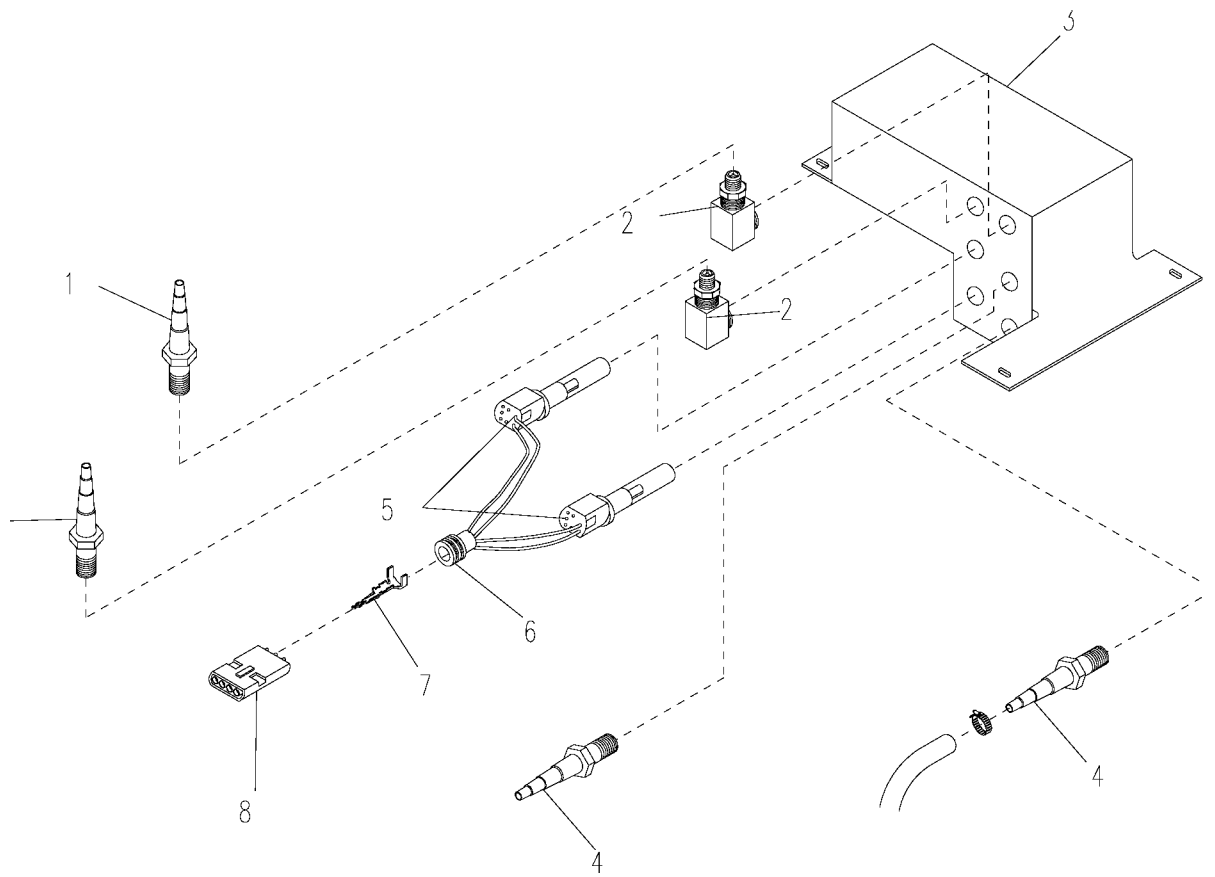

Figure C-5. Fuel Day Tank Assembly, SICPS

Section II.

ARMY TM 9-6115-670-14&P

(1) Item No	(2) SMR CODE	(3) NSN	(4) CAGEC	(5) Part Number	(6) Description and Usable on Code (UOC)	(7) QTY
GROUP 0103 FUEL TANK ASSEMBLY, SICPS						
FIG C-5						
1	PAOZZA	4730-01-017-5119	97403	13217E7108-17	ADAPTER, STRAIGHT, PI..... UOC:ABC,FPB	2
2	XBOZZA		81343	2-2-140239CA	ELBOW, PIPE..... UOC:ABC,FPB	2
3	XBOZZA		97403	13230E6298	TANK, FUEL, 903A..... UOC:ABC,FPB	1
4	PAOZZA	4730-00-595-1721	97403	13217E7108-5	ADAPTER, STRAIGHT, PI..... UOC:ABC,FPB	2
5	PAOZZA	5930-01-262-7827	04034	76141	SWITCH, LIQUID LEVEL..... UOC:ABC,FPB	2
6	XBOZZA		97403	13230E6242-6	SEAL, CABLE..... UOC:ABC,FPB	4
7	XBOZZA		97403	13230E6240-1	SOCKET, TERMINAL..... UOC:FPB	4
8	PAOZZA	5935-01-308-8599	45152	1788880	CONNECTOR BODY, PLUG..... UOC:ABC,FPB	1

End of Figure

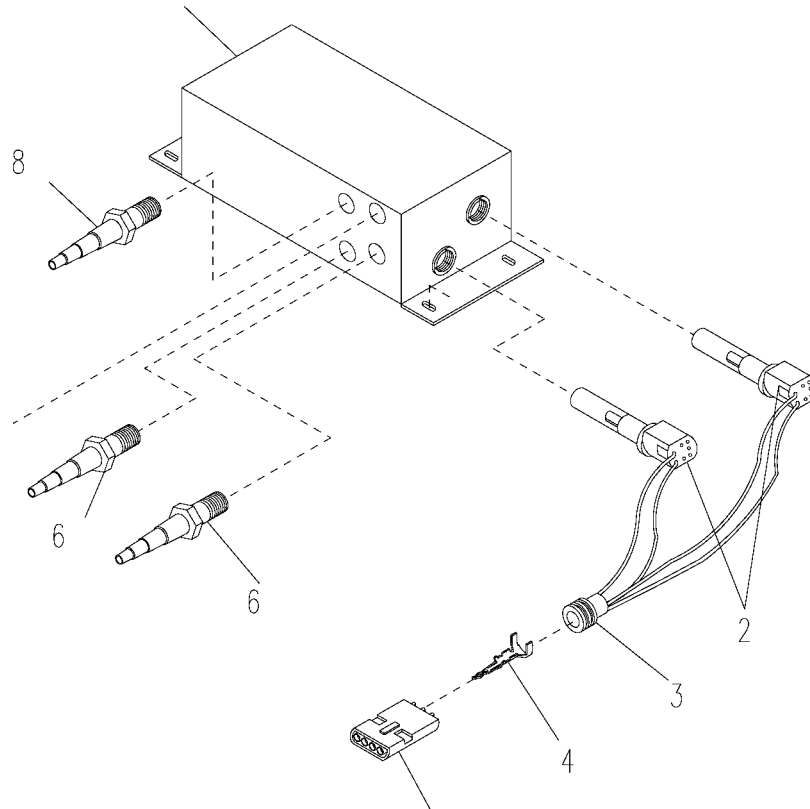

Figure C-6. Fuel Day Tank Assembly, JTACS/WIN-T

Section II.

ARMY TM 9-6115-670-14&P

(1) Item No	(2) SMR CODE	(3) NSN	(4) CAGEC	(5) Part Number	(6) Description and Usable on Code (UOC)	(7) QTY
					GROOUP 0104 FUEL TANK ASSEMBLY JTACS/WIN-T	
					FIG C-6	
1	XBOZZA		97403	13230E6670	TANK, FUEL, 903C.....	1
					UOC:FPA, LTG	
2	PAOZZA	5340-01-480-1364	97403	13230E6680	SWITCH, LIQUID LEVEL.....	2
					UOC:FPA, LTG	
3	PAOZZA	5975-01-310-5011	77060	12015323	BOOT, DUST AND MOIST.....	1
					UOC:FPA, LTG	
4	PAFZZA	5999-01-323-4929	77060	1208 9188	CONTACT, ELECTRICAL.....	4
					UOC:LTG	
4	PAFZZA	5999-01-500-9309	29381	2126003A	CONTACT, ELECTRICAL.....	4
					UOC:FPA	
5	PAOZZA	5935-01-308-8599	45152	1788880	CONNECTOR BODY, PLUG.....	1
					UOC:FPA, LTG	
6	PAOZZA	4730-00-595-1721	97403	13217E7108-5	ADAPTER, STRAIGHT, PI.....	2
					UOC:FPA, LTG	
7	PAOZZA	4730-00-226-8874	19207	12325823	REDUCER, PIPE.....	1
					UOC:LTG	
7	PAOZZA	4730-00-959-1628	30780	1-2CD45B	ELBOW, PIPE.....	1
					UOC:FPA	
8	PAOZZA	4730-01-017-5119	97403	13217E7108-17	ADAPTER, STRAIGHT, PI.....	1
					UOC:FPA, LTG	

End of Figure

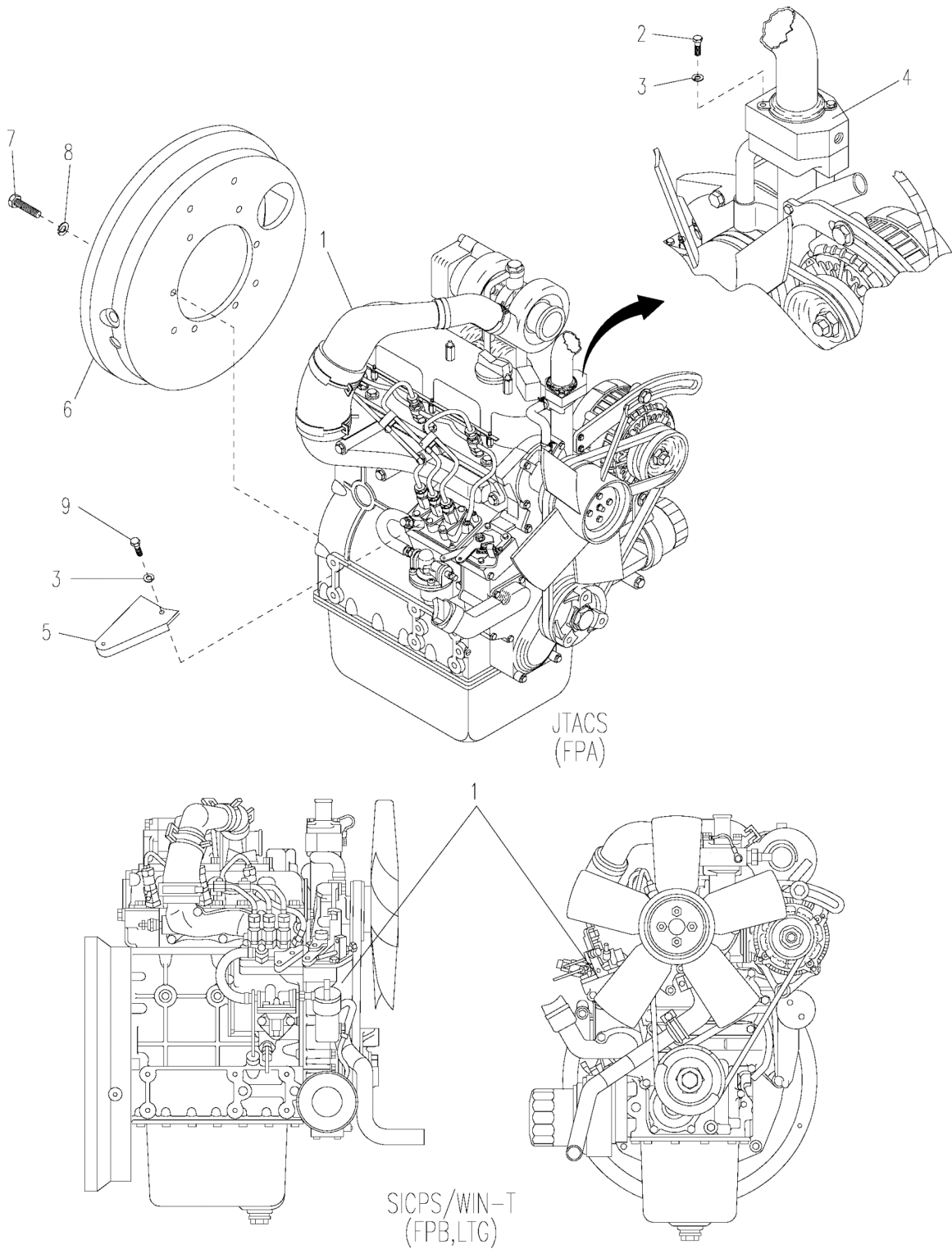

Figure C-7. Engine Assembly

Section II.

ARMY TM 9-6115-670-14&P

(1) Item No	(2) SMR CODE	(3) NSN	(4) CAGEC	(5) Part Number	(6) Description and Usable on Code (UOC)	(7) QTY
GROUP 0105 ENGINE ASSEMBLE						
FIG C-7						
1	PAFHDA	2815-01-456-6955	97403	13230E6303	ENGINE,DIESEL SEE FIGURE C-8 FOR BREAKDOWN..... UOC:FPB,ABC,LTG	1
1	PAFHAA	2815-01-494-7123	29381	3111001Y	ENGINE,DIESEL..... UOC:FPA	1
2	PAFZZA	5306-01-479-2590	80204	B18235B06050N	BOLT,MACHINE..... UOC:FPB,ABC,LTG	2
2	PAHZZA	5306-01-500-4869	29381	1142007A	BOLT,MACHINE..... UOC:FPA	2
3	PAFZZA	5310-01-478-5935	05047	W212NAA0060NN041 NNCG1	WASHER,LOCK..... UOC:FPB,ABC,LTG	2
3	PAHZZA	5310-01-500-6062	29381	1324003A	WASHER,LOCK..... UOC:FPA	3
4	XBZZA		97403	13230E6307	BLOCK,TEMP SENSOR..... UOC:FPB,FPA,ABC,LTG	1
5	XBHZZA		97403	13230E6323	PLATE,PIVOT,LINKAGE..... UOC:LTG,FPB,FPA,ABC	1
6	XBHZZA		97403	13230E6322	BELL HOUSING..... UOC:LTG,FPB,ABC	1
6	XBHZZA		29381	4230002D	BELL HOUSING..... UOC:FPA	1
7	PAHZZA	5306-01-500-2780	80204	B18235B08020-1	BOLT,MACHINE..... UOC:FPB,ABC	8
7	PAHZZA	5306-01-500-2780	80204	B18235B08020-1	BOLT,MACHINE..... UOC:LTG	10
7	PAHZZA	5306-01-500-2740	29381	1143002A	BOLT,MACHINE..... UOC:FPA	10
8	PAHZZA	5310-01-478-5620	80204	B18212HRCZ080	WASHER,LOCK..... UOC:FPB,ABC	8
8	PAHZZA	5310-01-478-5620	80204	B18212HRCZ080	WASHER,LOCK..... UOC:LTG	10
8	PAHZZA	5310-01-500-6066	29381	1324004A	WASHER,LOCK..... UOC:FPA	10
9	PAOZZA	5306-01-479-0352	0XWR1	19202-91010	BOLT,MACHINE..... UOC:FPB,FPA,ABC,LTG	1
9	PAHZZA	5306-01-500-6209	29381	1142004A	BOLT,MACHINE..... UOC:FPA	1

End of Figure

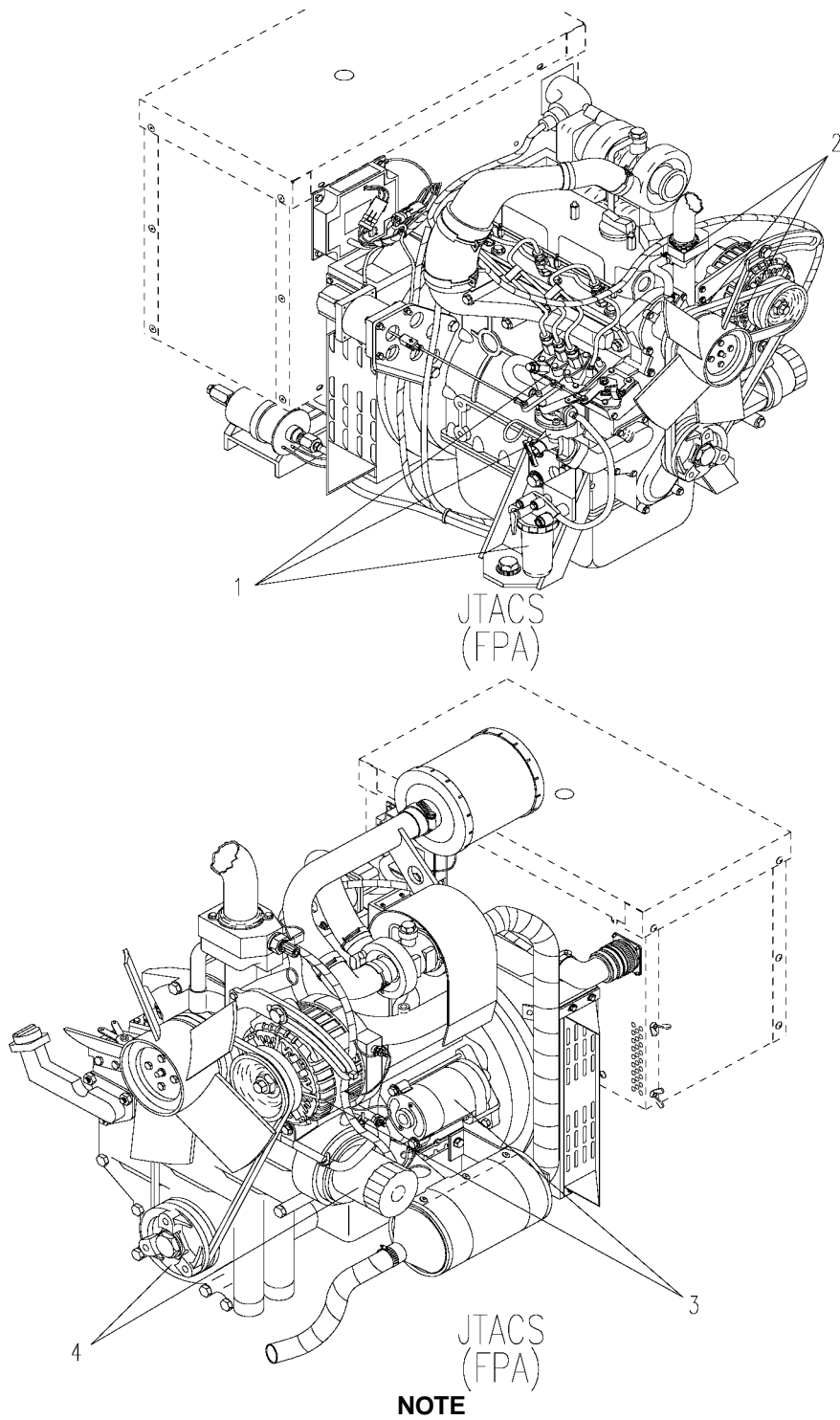

NOTE

SICPS/WIN-T engine oil filter is located on opposite side.

Figure C-8. Engine, Diesel, Turbo, 3 Cylinder, Liquid Cooled (Sheet 1 of 8)

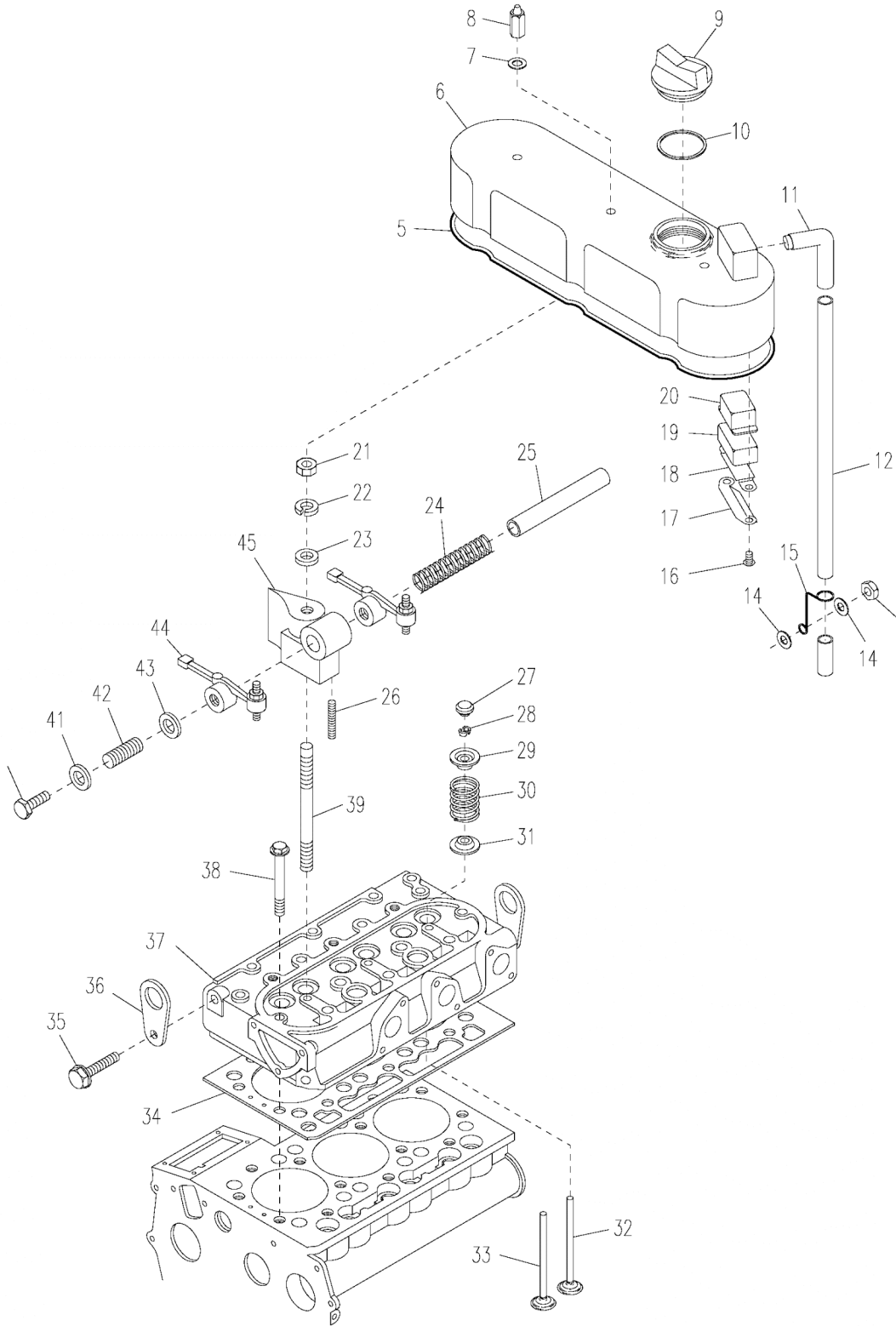

Figure C-8. Engine, Diesel, Turbo, 3 Cylinder, Liquid Cooled (Sheet 2 of 8)

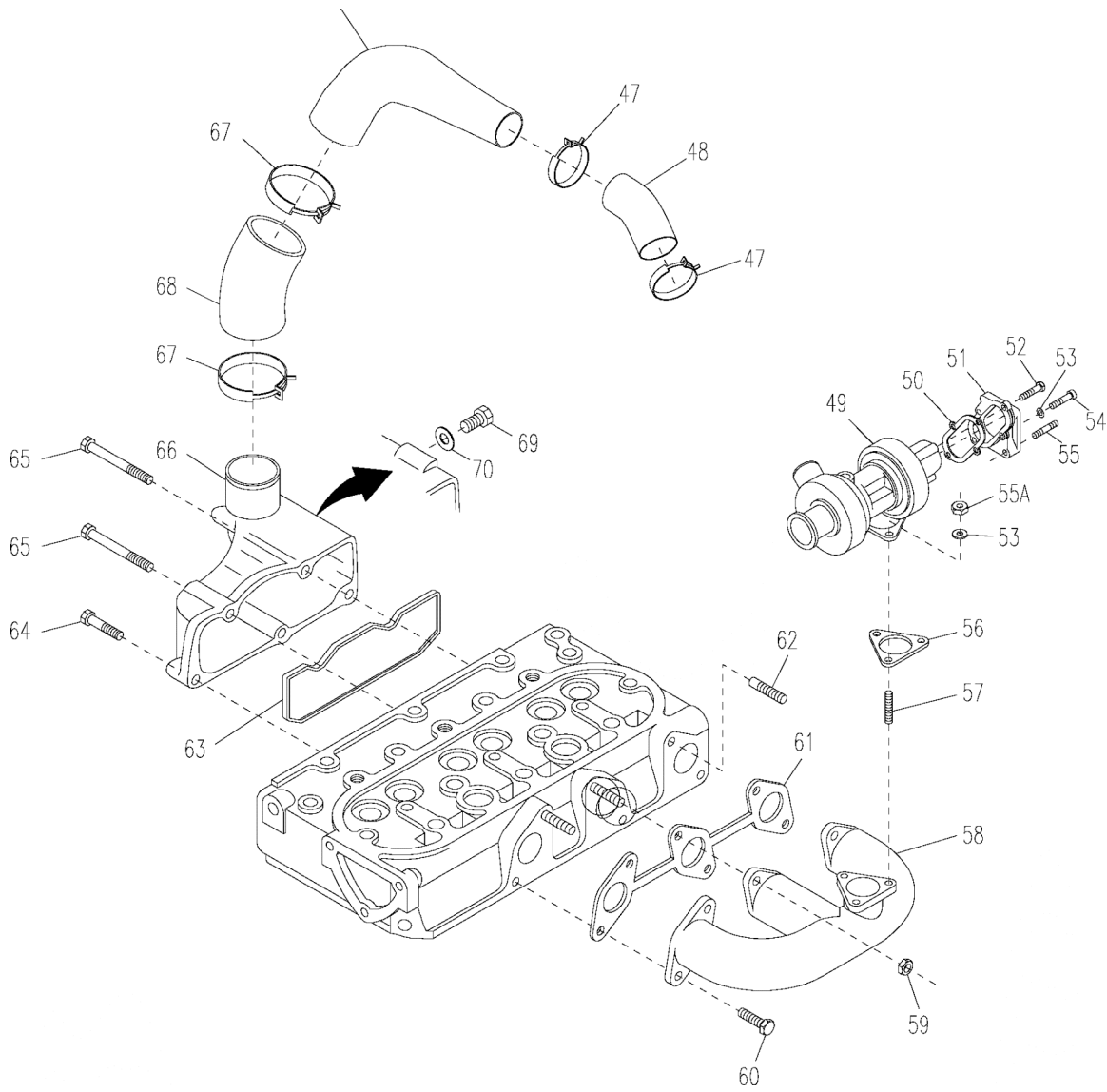

Figure C-8. Engine, Diesel, Turbo, 3 Cylinder, Liquid Cooled (Sheet 3 of 8)

Section II

ARMY TM 9-6115-670-14&P

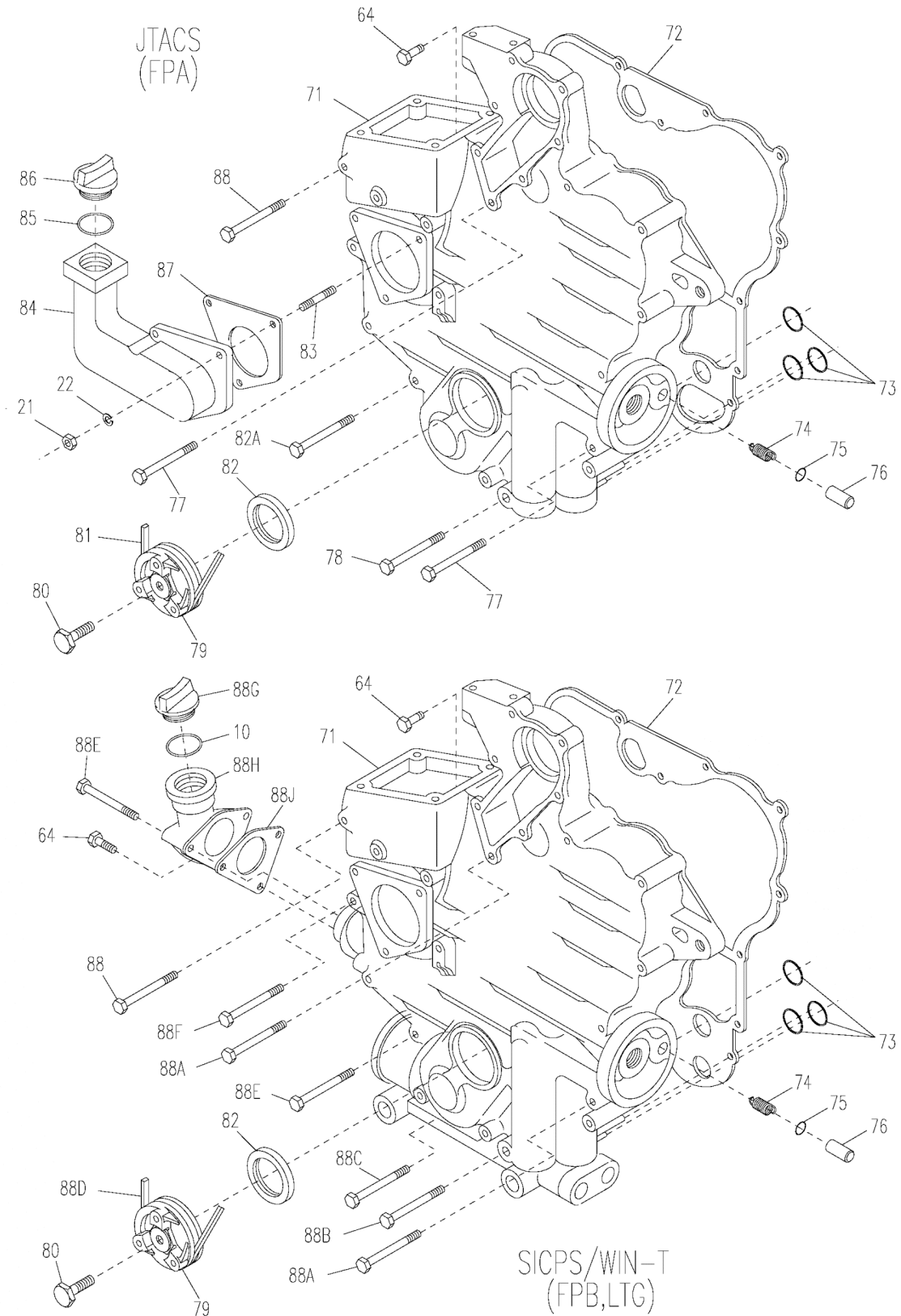

Figure C-8. Engine, Diesel, Turbo, 3 Cylinder, Liquid Cooled (Sheet 4 of 8)

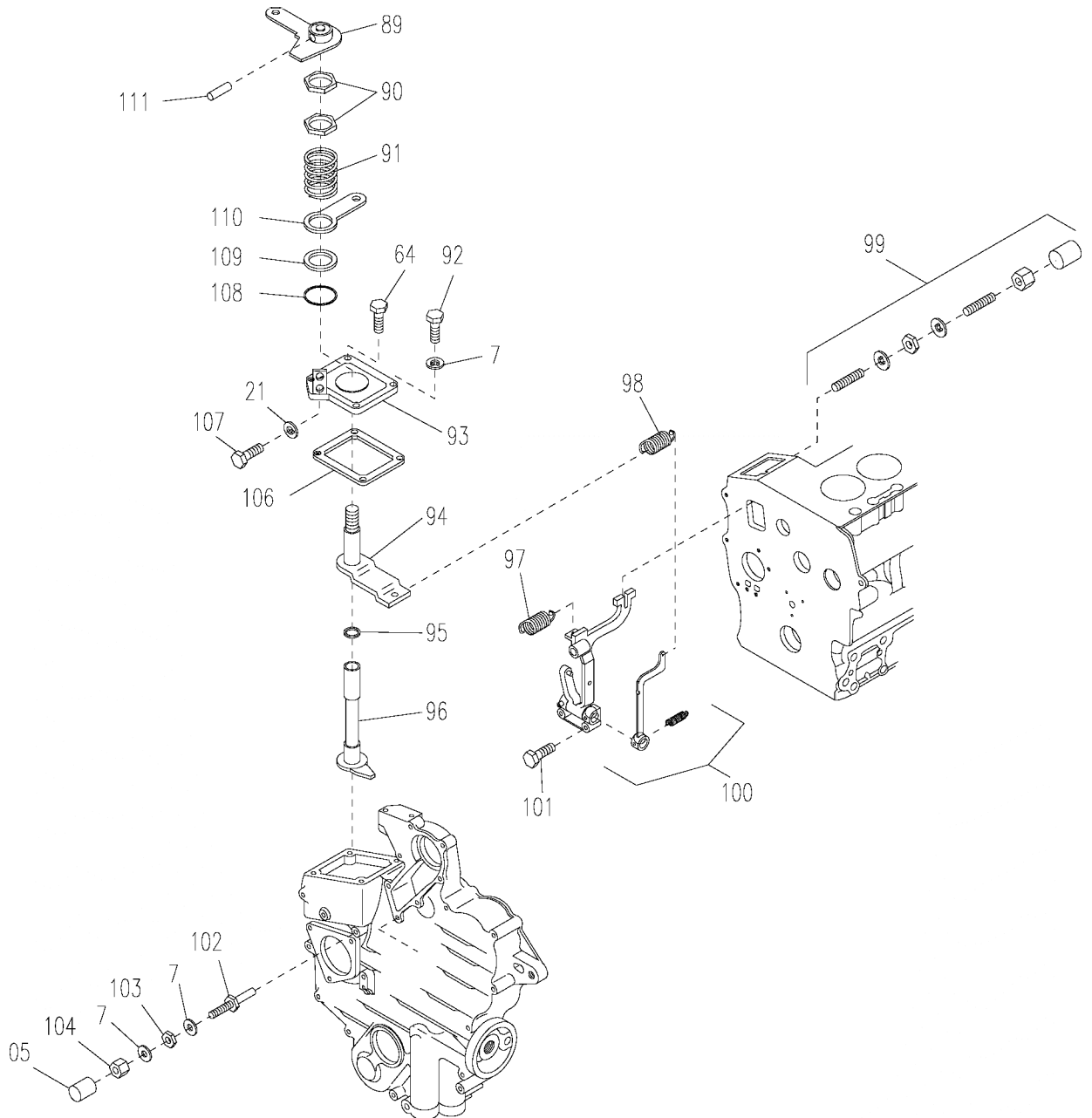

Figure C-8. Engine, Diesel, Turbo, 3 Cylinder, Liquid Cooled (Sheet 5 of 8)

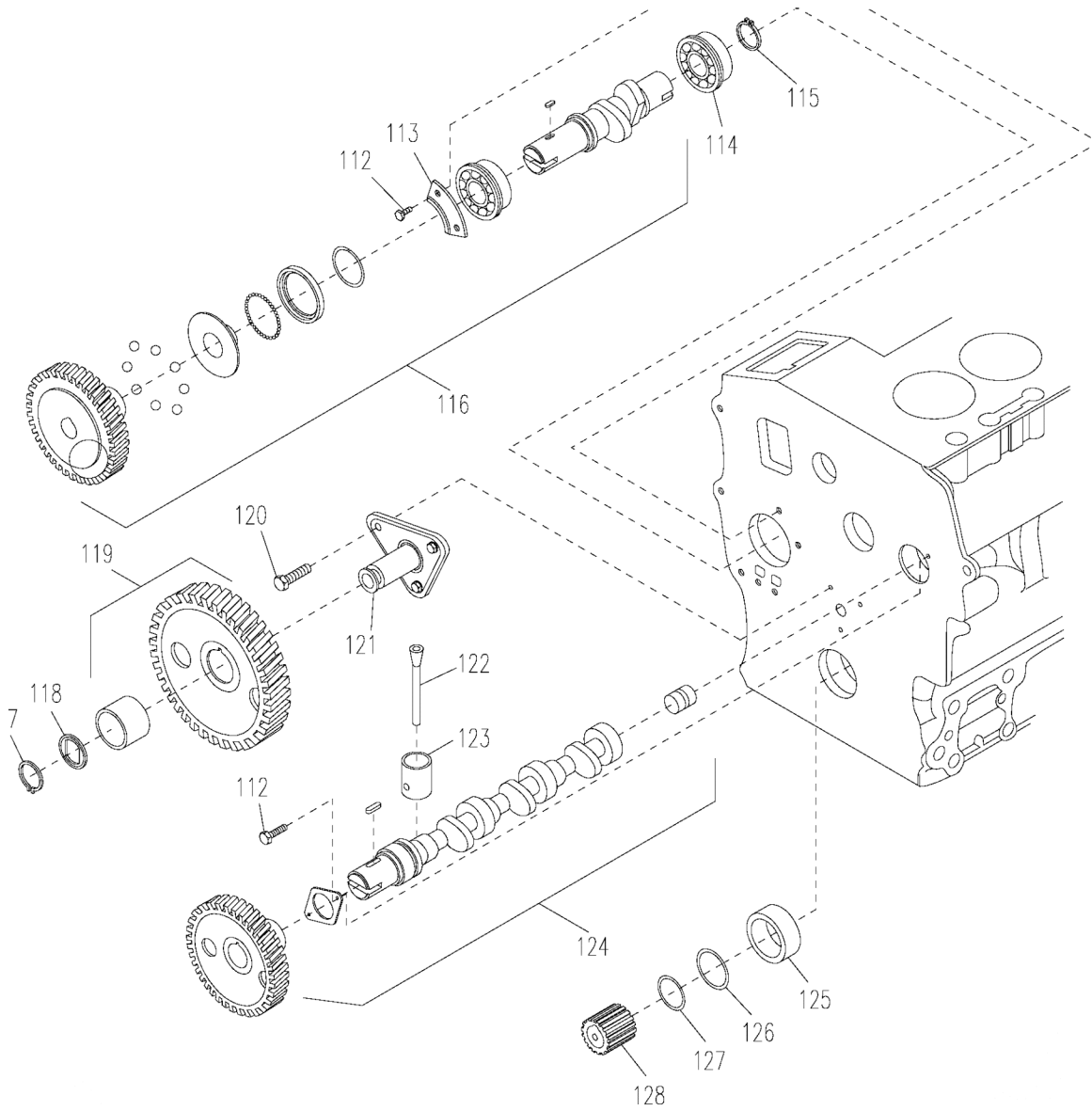

Figure C-8. Engine, Diesel, Turbo, 3 Cylinder, Liquid Cooled (Sheet 6 of 8)

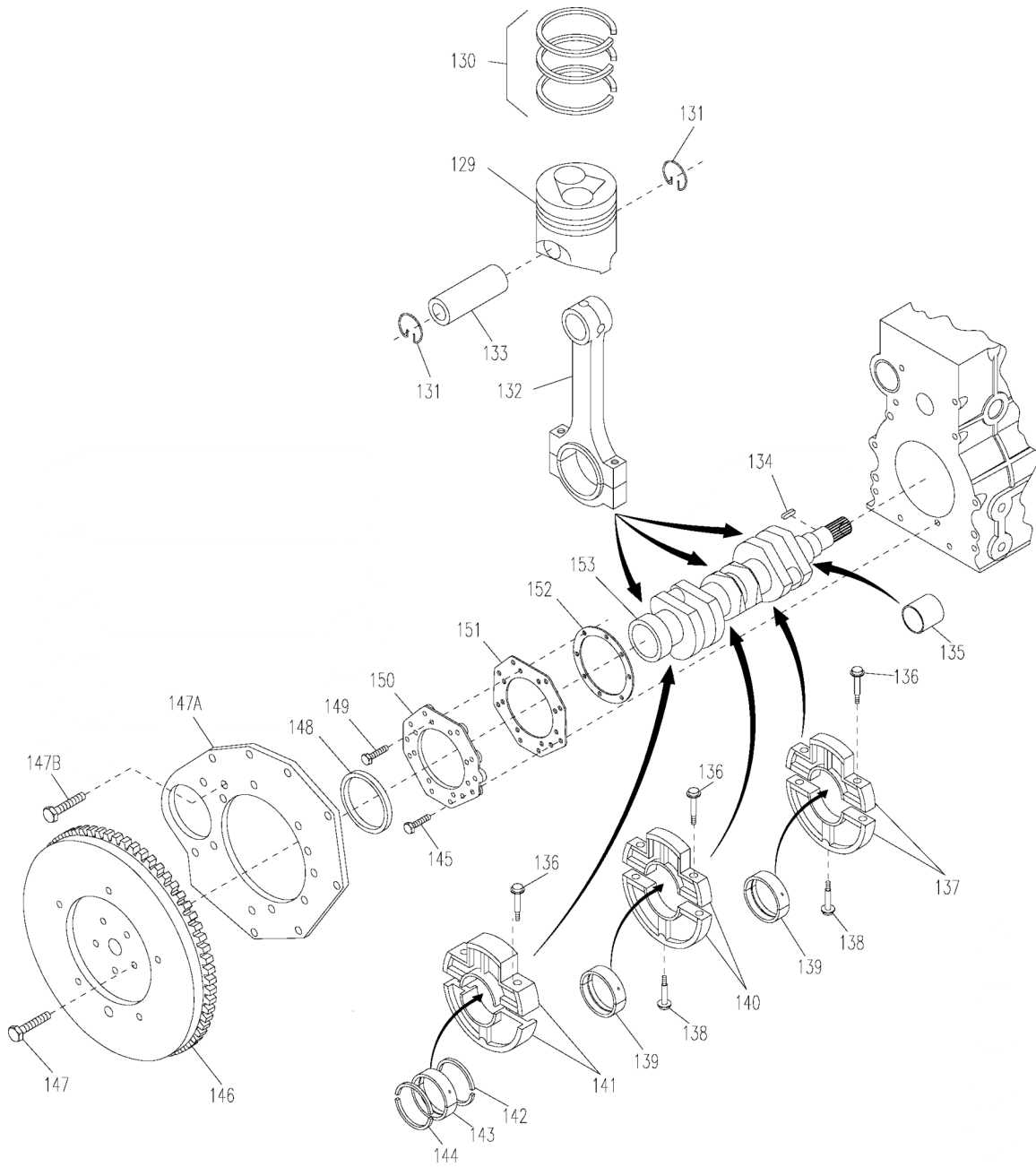

Figure C-8. Engine, Diesel, Turbo, 3 Cylinder, Liquid Cooled (Sheet 7 of 8)

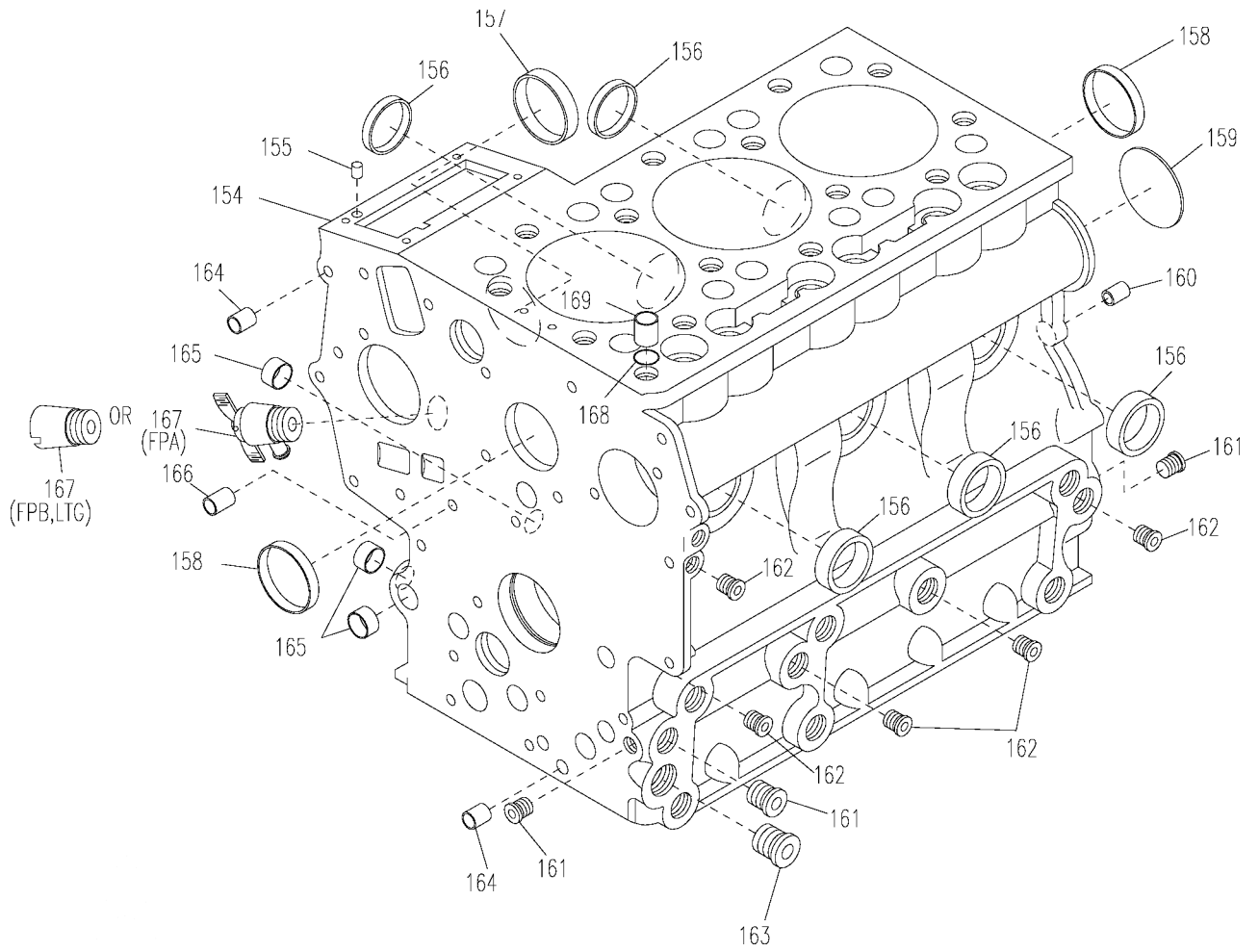

Figure C-8. Engine, Diesel, Turbo, 3 Cylinder, Liquid Cooled (Sheet 8 of 8)

Section II.

ARMY TM 9-6115-670-14&P

(1) Item No	(2) SMR CODE	(3) NSN	(4) CAGEC	(5) Part Number	(6) Description and Usable on Code (UOC)	(7) QTY
					GROUP 010501 ENGINE;DIESEL, TURBO,3 CYLINDER, LIQUID COOLED	
					FIG C-8	
1	XCFFFA		97403	SYSTEM-4	FUEL SYSTEM SEE FIGURE C-12 FOR BREAKDOWN.....	1
					UOC:FPB,FPA,ABC,LTG	
2	XCFFFA		97403	SYSTEM-2	COOLING SYSTEM SEE FIGURE C-10 FOR BREAKDOWN.....	1
					UOC:LTG,FPB,FPA,ABC	
3	XCOOOA		97403	SYSTEM-3	ELECTRICAL SYSTEM SEE FIGURE C-11 FOR BREAKDOWN.....	1
					UOC:FPB,FPA,ABC,LTG	
4	XCHHHA		97403	SYSTEM-1	LUBRICATING SYSTEM SEE FIGURE C-9 FOR BREAKDOWN.....	1
					UOC:FPB,FPA,ABC,LTG	
5	PAFZZA	5330-01-478-6369	0XWR1	16861-14522	GASKET.....	1
					UOC:FPB,FPA,ABC,LTG	
6	XBFZZA		0XWR1	16862-14500	COVER, CYLINDER HEAD.....	1
					UOC:FPB,FPA,ABC,LTG	
7	PAOZZA	5330-01-478-4911	0XWR1	15601-96650	GASKET.....	7
					UOC:FPB,FPA,ABC,LTG	
8	PAOZZA	5310-01-478-5177	0XWR1	15841-14620	NUT, PLAIN, CAP.....	3
					UOC:FPB,FPA,ABC,LTG	
9	PAOZZA	4730-01-436-1167	0XWR1	15852-33140	PLUG, PIPE.....	1
					UOC:FPB,FPA,ABC,LTG	
10	PAOZZA	5331-01-320-9557	0XWR1	04811-50300	O-RING.....	1
					UOC:FPB,ABC,LTG	
11	XBOZZA		0XWR1	15881-05550	ELBOW, BREATHER PIPE.....	1
					UOC:FPB,FPA,ABC,LTG	
12	XBOZZA		0XWR1	15841-05510	TUBE, BREATHER.....	1
					UOC:FPB,FPA,ABC,LTG	
13	PAOZZA	5310-01-320-7060	0XWR1	02114-50080	NUT, PLAIN, HEXAGON.....	1
					UOC:FPB,FPA,ABC,LTG	
14	PAFZZA	5310-01-478-5120	0XWR1	04013-60080	WASHER, FLAT.....	2
					UOC:FPB,FPA,ABC,LTG	
15	XBOZZA		0XWR1	15881-05590	HOLDER, PIPE.....	1
					UOC:FPB,FPA,ABC,LTG	
16	PAFZZA	5305-01-500-8690	0XWR1	16861-93310	SCREW, ASSEMBLED WAS.....	2
					UOC:LTG,FPB,FPA,ABC	
17	XBOZZA		0XWR1	15841-05370	SHIELD, BREATHER.....	1
					UOC:FPB,FPA,ABC,LTG	
18	XBOZZA		0XWR1	15841-05140	PLATE, BREATHER.....	1
					UOC:FPB,FPA,ABC,LTG	
19	PAOZZA	2815-01-478-7480	0XWR1	15841-0567-0	BREATHER.....	1
					UOC:FPB,FPA,ABC,LTG	
20	XBOZZA		0XWR1	15841-05150	COVER, BREATHER.....	1
					UOC:FPB,FPA,ABC,LTG	
21	PAOZZA	5310-01-320-7038	0XWR1	02056-50060	NUT, PLAIN, HEXAGON.....	3
					UOC:FPA	
22	PAHZZA	5310-01-320-7100	0XWR1	04512-60060	WASHER, LOCK.....	3
					UOC:FPB,ABC,LTG	
23	PAHZZA	5310-01-478-5171	0XWR1	04012-50060	WASHER, FLAT.....	3
					UOC:FPB,FPA,ABC,LTG	
24	PAHZZA	5360-01-486-5154	0XWR1	14601-14310	SPRING, HELICAL, COMP.....	2
					UOC:LTG,FPB,FPA,ABC	
25	PAHZZA	2815-01-500-4564	0XWR1	15861-14263	SHAFT, STRAIGHT.....	1
					UOC:FPB,FPA,ABC,LTG	
26	PAHZZA	5315-01-500-0653	0XWR1	05411-00420	PIN, SPRING.....	1
					UOC:FPB,FPA,ABC,LTG	

Section II.

ARMY TM 9-6115-670-14&P

(1) Item No	(2) SMR CODE	(3) NSN	(4) CAGEC	(5) Part Number	(6) Description and Usable on Code (UOC)	(7) QTY
					GROUP 010501 ENGINE;DIESEL, TURBO,3 CYLINDER, LIQUID COOLED	
					FIG C-8	
27	PAHZZA	2815-01-500-6972	OXWR1	16851-13280	CAP, VALVE.....	6
					UOC:FPB,FPA,ABC,LTG	
28	PAHZZA	2815-99-610-4361	S8029	14601-1336-0	COLLET, VALVE SPRING.....	6
					UOC:FPB,FPA,ABC,LTG	
29	PAHZZA	5340-99-235-4309	OXWR1	14601-13330	SEAT, HELICAL COMPRE.....	6
					UOC:FPB,FPA,ABC,LTG	
30	PAHZZA	5360-99-911-5629	S8029	14601-1324-0	SPRING, HELICAL, COMP.....	6
					UOC:FPB,FPA,ABC,LTG	
31	PAHZZA	5330-01-478-6002	OXWR1	11420-13150	SEAL, PLAIN.....	6
					UOC:FPB,FPA,ABC,LTG	
32	PAHZZA	2815-01-478-7465	OXWR1	14601-1312-0	VALVE, POPPET, ENGINE.....	3
					UOC:FPB,FPA,ABC,LTG	
33	PAHZZA	2815-01-478-7450	OXWR1	14601-1311-0	VALVE, POPPET, ENGINE.....	3
					UOC:FPB,FPA,ABC,LTG	
34	PAOZZA	5330-01-478-4843	OXWR1	16871-03310	GASKET.....	1
					UOC:FPA	
34	PAHZZA	5330-01-500-3497	OXWR1	16881-03310	GASKET.....	1
					UOC:ABC,FPB,LTG	
35	PAFZZA	5306-01-500-4266	OXWR1	01123-60816	BOLT, MACHINE.....	2
					UOC:FPB,FPA,ABC,LTG	
36	XBOZZA		OXWR1	15221-01750	EYE, LIFTING.....	2
					UOC:FPB,FPA,ABC,LTG	
37	PAHHHA	2815-01-494-7963	OXWR1	16873-03042	HEAD, DIESEL ENGINE SEE FIGURE C-15 FOR BREAKDOWN.....	1
					UOC:FPB,FPA,ABC,LTG	
38	XBHZZA		OXWR1	14601-03450	BOLT, HEX HEAD.....	14
					UOC:FPB,FPA,ABC,LTG	
39	PAOZZA	5307-01-485-8389	OXWR1	14601-14410	STUD, PLAIN.....	3
					UOC:FPB,FPA,ABC,LTG	
40	PAHZZA	5306-01-393-4861	31013	01023-50610	BOLT, MACHINE.....	2
					UOC:FPB,FPA,ABC,LTG	
41	PAHZZA	5310-01-500-2385	OXWR1	15841-94022	WASHER, FLAT.....	2
					UOC:FPB,FPA,ABC,LTG	
42	PAHZZA	5340-01-478-7436	OXWR1	15841-14320	INSERT, SELF-LOCKING.....	2
					UOC:FPB,FPA,ABC,LTG	
43	PAHZZA	5365-01-500-3268	OXWR1	16871-14430	SPACER, SLEEVE.....	2
					UOC:LTG,FPB,FPA,ABC	
44	PAHZZA	2815-01-478-7538	OXWR1	15841-1403-0	ROCKER ARM, ENGINE P.....	6
					UOC:FPB,FPA,ABC,LTG	
45	XBHZZA		OXWR1	15841-14350	BRACKET, ROCKER ARM.....	3
					UOC:FPB,FPA,ABC,LTG	
46	XBFZZA		OXWR1	16241-11640	ELBOW, REDUCING.....	1
					UOC:FPB,FPA,ABC,LTG	
47	PROZZA	4730-01-478-7128	OXWR1	16241-72971	CLAMP, HOSE.....	2
					UOC:FPB,FPA,ABC,LTG	
47	PAOZZA	4730-01-500-6461	OXWR1	16241-72970	CLAMP, HOSE.....	2
					UOC:FPB,FPA,ABC,LTG	
48	PAOZZA	4720-01-500-6508	OXWR1	16881-11630	HOSE, PREFORMED.....	1
					UOC:FPB,FPA,ABC,LTG	
49	XBFZZA		OXWR1	16881-17010	TURBOCHARGER ASSY.....	1
					UOC:FPB,FPA,ABC,LTG	
50	PAFZZA	5330-01-500-3190	OXWR1	16292-17110	GASKET.....	1
					UOC:LTG,FPB,FPA,ABC	
51	XBOZZA		OXWR1	16881-12320	FLANGE, MUFFLER.....	1
					UOC:FPB,FPA,ABC,LTG	

Section II.

ARMY TM 9-6115-670-14&P

(1) Item No	(2) SMR CODE	(3) NSN	(4) CAGEC	(5) Part Number	(6) Description and Usable on Code (UOC)	(7) QTY
					GROUP 010501 ENGINE;DIESEL, TURBO,3 CYLINDER, LIQUID COOLED	
					FIG C-8	
52	PAOZZA	5305-14-514-1576	OXWR1	01123-50828	BOLT, MACHINE	2
					UOC:FPB,FPA,ABC,LTG	
53	XBFZZA	5310-01-321-3477	OXWR1	04512-60080	WASHER, LOCK	5
					UOC:FPB,FPA,ABC,LTG	
54	PAOZZA	5306-01-479-0369	OXWR1	01311-10828	BOLT, MACHINE	2
					UOC:FPB,FPA,ABC,LTG	
55	PAOZZA	5307-01-485-8363	OXWR1	01513-50828	STUD, PLAIN	4
					UOC:FPB,FPA,ABC,LTG	
55A	PAOZZA	5310-01-393-6781	31013	02156-50080	NUT, PLAIN, HEXAGON	3
					UOC:FPB,FPA,ABC,LTG	
56	PAFZZA	5330-01-500-3519	OXWR1	16299-17100	GASKET	1
					UOC:FPB,FPA,ABC,LTG	
57	PAFZZA	5307-01-500-8414	OXWR1	01513-60820	STUD, PLAIN	3
					UOC:FPB,FPA,ABC,LTG	
58	XBFZZA		OXWR1	16881-12310	MANIFOLD, EXHAUST	1
					UOC:FPB,FPA,ABC,LTG	
59	PAFZZA	5310-01-478-5187	OXWR1	02756-50060	NUT, PLAIN, HEXAGON	3
					UOC:FPB,FPA,ABC,LTG	
60	PAFZZA	5306-01-500-8704	OXWR1	01759-50616	BOLT, MACHINE	3
					UOC:FPB,FPA,ABC,LTG	
61	PAFZZA	5330-01-478-5169	OXWR1	15862-12350	GASKET	1
					UOC:FPB,FPA,ABC,LTG	
62	PAFZZA	5307-01-501-0020	OXWR1	01513-50618	STUD, PLAIN	3
					UOC:FPB,FPA,ABC,LTG	
63	PAFZZA	5330-01-478-5164	OXWR1	15861-11820	GASKET	1
					UOC:FPB,FPA,ABC,LTG	
64	PAHZZA	5305-14-514-1569	OXWR1	01023-50618	BOLT, MACHINE	7
					UOC:FPB,FPA,ABC,LTG	
65	PAHZZA	5306-01-501-0015	OXWR1	01023-60645	BOLT, MACHINE	3
					UOC:FPB,FPA,ABC,LTG	
66	XBFZZA		OXWR1	15862-11770	MANIFOLD, INTAKE	1
					UOC:FPA	
66	XBFZZA		OXWR1	16881-11770	MANIFOLD, INTAKE	1
					UOC:FPB,ABC,LTG	
67	PAOZZA	4730-01-500-6211	OXWR1	16241-11720	CLAMP, HOSE	2
					UOC:FPB,FPA,ABC,LTG	
68	PROZZA	4730-01-478-7127	OXWR1	16241-11721	CLAMP, HOSE	2
					UOC:FPB,FPA,ABC,LTG	
68	PAOZZA	4720-01-500-6509	OXWR1	16881-11670	HOSE, PREFORMED	1
					UOC:LTG,FPB,FPA,ABC	
69	PAFZZA	4730-01-504-9888	OXWR1	16881-96010	PLUG, PIPE	1
					UOC:FPB,ABC,LTG	
70	PAFZZA	5330-01-500-3528	OXWR1	04724-00140	GASKET	1
					UOC:FPB,ABC,LTG	
71	XBHZZA		OXWR1	16881-04020	CASE, GEAR 903C	1
					UOC:FPB,ABC,LTG	
71	XBHZZA		OXWR1	15881-04026	CASE, GEAR 903B	1
					UOC:FPA	
72	PAHZZA	5330-01-478-5153	OXWR1	15862-04132	GASKET	1
					UOC:FPB,FPA,ABC,LTG	
73	PAHZZA	5331-01-478-4867	OXWR1	04811-06130	PACKING, PREFORMED	3
					UOC:FPB,FPA,ABC,LTG	
74	PAFZZA	5360-01-486-3739	OXWR1	16851-36950	SPRING, HELICAL, COMP	1
					UOC:FPB,FPA,ABC,LTG	
75	PAFZZA	4820-01-478-7226	OXWR1	07715-03211	BALL, VALVE, PORTED	1
					UOC:FPB,FPA,ABC,LTG	

Section II.

ARMY TM 9-6115-670-14&P

(1) Item No	(2) SMR CODE	(3) NSN	(4) CAGEC	(5) Part Number	(6) Description and Usable on Code (UOC)	(7) QTY
					GROUP 010501 ENGINE;DIESEL, TURBO,3 CYLINDER, LIQUID COOLED	
					FIG C-8	
76	PAFZZA	2815-01-478-7478	OXWR1	15841-3693-0	INSERT,ENGINE VALVE..... UOC:FPB,FPA,ABC,LTG	1
77	PAHZZA	5306-01-479-0355	OXWR1	15841-91010	BOLT,MACHINE..... UOC:ABC,FPA,FPB,LTG	5
78	PAHZZA	2940-99-980-8342	S8029	01023-50675	BOLT..... UOC:FPA	1
79	XBFZZA		OXWR1	16875-74280	PULLEY,CRANKSHAFT..... UOC:FPB,FPA,ABC,LTG	1
80	PAOZZA	5306-01-479-0367	OXWR1	15881-91030	BOLT,MACHINE..... UOC:FPB,FPA,ABC,LTG	1
81	PAOZZA	3030-01-490-6137	OXWR1	19217-97010	BELT,V..... UOC:FPA	1
82	PAHZZA	5330-01-478-4887	OXWR1	15877-04140	SEAL,PLAIN..... UOC:FPB,FPA,ABC,LTG	1
82A	PAHZZA	5306-01-500-8701	OXWR1	01023-60650	BOLT,MACHINE..... UOC:FPA	8
83	PAOZZA	5307-01-485-8384	OXWR1	15221-88210	STUD,PLAIN..... UOC:FPA	3
84	XBOZZA		OXWR1	15846-33110	FLANGE,OIL FILLER..... UOC:FPA	1
85	PAOZZA	5331-01-478-4865	OXWR1	04811-06230	PACKING,PREFORMED..... UOC:FPA	1
86	PAOZZA	2930-01-500-6596	OXWR1	13811-33080	CAP,FILLER OPENING..... UOC:FPA	1
87	PAFZZA	5330-01-500-3501	OXWR1	19461-88132	GASKET..... UOC:FPA	1
88	PAHZZA	5306-01-500-8702	OXWR1	01023-60670	BOLT,MACHINE..... UOC:FPB,FPA,ABC,LTG	1
88A	PAHZZA	5306-01-479-0355	OXWR1	15841-91010	BOLT,MACHINE..... UOC:FPB,ABC,LTG	3
88B	PAHZZA	5306-01-501-0017	OXWR1	17563-91010	BOLT,MACHINE..... UOC:FPB,ABC,LTG	1
88C	PAHZZA	5306-01-435-8407	OXWR1	01023-50680	BOLT,MACHINE..... UOC:FPB,ABC,LTG	2
88D	PAOZZA	3030-01-500-8099	OXWR1	19805-72530	BELT,V..... UOC:FPB,ABC,LTG	1
88E	PAHZZA	5306-01-500-8701	OXWR1	01023-60650	BOLT,MACHINE..... UOC:FPB,ABC,LTG	9
88F	PAHZZA	5306-01-320-7029	S4532	01023-50660	BOLT,MACHINE..... UOC:FPB,ABC,LTG	1
88G	PAHZZA	4730-01-436-1167	OXWR1	15852-33140	PLUG,PIPE..... UOC:FPB,ABC,LTG	1
88H	XBOZZA		OXWR1	19090-11310	FLANGE,OIL FILLER..... UOC:FPB,ABC,LTG	1
88J	PAHZZA	5330-01-500-3512	OXWR1	19483-33120	GASKET..... UOC:FPB,ABC,LTG	1
89	XBFZZA		OXWR1	19837-57720	LEVER,ENGINE STOP..... UOC:FPB,FPA,ABC,LTG	1
90	PAFZZA	5310-01-478-5178	OXWR1	15841-92010	NUT,PLAIN,HEXAGON..... UOC:FPB,FPA,ABC,LTG	2
91	PAHZZA	5360-01-486-5180	OXWR1	15841-57920	SPRING,HELICAL,TORS..... UOC:FPB,FPA,ABC,LTG	1
92	PAHZZA	5305-14-514-1572	OXWR1	01053-50618	BOLT,MACHINE..... UOC:FPB,FPA,ABC,LTG	2
93	XBHZZA		OXWR1	15841-57110	PLATE,THROTTLE..... UOC:FPB,FPA,ABC,LTG	1

Section II.

ARMY TM 9-6115-670-14&P

(1) Item No	(2) SMR CODE	(3) NSN	(4) CAGEC	(5) Part Number	(6) Description and Usable on Code (UOC)	(7) QTY
					GROUP 010501 ENGINE;DIESEL, TURBO,3 CYLINDER, LIQUID COOLED	
					FIG C-8	
94	XBHZZA		OXWR1	15841-56110	SHAFT, THROTTLE	1
					UOC:FPB, FPA, ABC, LTG	
95	PAHZZA	5331-01-478-5999	OXWR1	04811-10070	PACKING, PREFORMED	1
					UOC:FPB, FPA, ABC, LTG	
96	XBHZZA		OXWR1	16878-57740	SHAFT, ENGINE STOP	1
					UOC:FPB, FPA, ABC, LTG	
97	PAHZZA	5360-01-486-3742	OXWR1	15841-56480	SPRING, HELICAL, EXTE	1
					UOC:FPB, FPA, ABC, LTG	
98	PAHZZA	5360-01-486-3906	OXWR1	19461-56412	SPRING, HELICAL, EXTE	1
					UOC:FPB, FPA, ABC, LTG	
99	PAHZZA	2990-01-478-5696	OXWR1	15841-54092	CONTROL, IDLE SPEED	1
					UOC:FPB, FPA, ABC, LTG	
100	XBHZZA		OXWR1	16000-56050	FORK LEVER ASSEMBLY	1
					UOC:FPB, FPA, ABC, LTG	
101	PAHZZA	5306-01-479-0363	OXWR1	01023-50635	BOLT, MACHINE	2
					UOC:FPB, FPA, ABC, LTG	
102	PAFZZA	5306-01-479-0366	OXWR1	15841-54122	BOLT, MACHINE	1
					UOC:FPB, FPA, ABC, LTG	
103	PAFZZA	5310-01-478-5181	OXWR1	15841-92020	NUT, PLAIN, HEXAGON	1
					UOC:FPB, FPA, ABC, LTG	
104	PAFZZA	5310-01-478-5186	OXWR1	15841-92330	NUT, PLAIN, CAP	1
					UOC:FPB, FPA, ABC, LTG	
105	PAFZZA	5340-01-478-7486	OXWR1	16241-54420	CAP, PROTECTIVE, NUT	1
					UOC:FPB, FPA, ABC, LTG	
106	PAHZZA	5330-01-478-5161	OXWR1	15841-57212	GASKET	1
					UOC:FPB, FPA, ABC, LTG	
107	PAOZZA	5306-01-479-0365	OXWR1	15108-57280	BOLT, MACHINE	2
					UOC:FPB, FPA, ABC, LTG	
108	PAHZZA	5331-01-478-4863	OXWR1	04811-10160	PACKING, PREFORMED	1
					UOC:FPB, FPA, ABC, LTG	
109	PAHZZA	5365-01-485-9240	OXWR1	15841-57240	SPACER, RING	1
					UOC:FPB, FPA, ABC, LTG	
110	XBHZZA		OXWR1	16667-57150	LEVER, THROTTLE	1
					UOC:FPB, FPA, ABC, LTG	
111	PAOZZA	5315-01-478-6939	OXWR1	05411-00318	PIN, SPRING	1
					UOC:FPB, FPA, ABC, LTG	
112	PAFZZA	5306-01-321-3371	S4532	01023-50612	BOLT, MACHINE	4
					UOC:FPB, FPA, ABC, LTG	
113	XBHZZA		OXWR1	15841-16320	STOP, FUEL CAMSHAFT	1
					UOC:FPB, FPA, ABC, LTG	
114	PAHZZA	3130-01-485-9253	OXWR1	08103-06203	BEARING UNIT, BALL	1
					UOC:FPB, FPA, ABC, LTG	
115	PAHZZA	5325-01-486-3846	OXWR1	04612-00170	RING, RETAINING	1
					UOC:FPB, FPA, ABC, LTG	
116	PAHZZA	2910-99-595-0571	K5F98	16861-16020	CAMSHAFT, SPECIAL	1
					UOC:FPB, FPA, ABC, LTG	
117	PAHZZA	5325-01-478-6921	OXWR1	15875-24320	RING, RETAINING	1
					UOC:FPB, FPA, ABC, LTG	
118	XBHZZA		OXWR1	15875-24370	COLLAR, IDLE GEAR	1
					UOC:FPB, FPA, ABC, LTG	
119	PAHZZA	3020-01-486-7673	OXWR1	15875-24013	GEAR, HELICAL	1
					UOC:FPB, FPA, ABC, LTG	
120	XDHZZA		S4532	01023-50614	BOLT, MACHINE	3
					UOC:FPB, FPA, ABC, LTG	
121	XBHZZA		OXWR1	15875-24250	SHAFT, IDLE GEAR	1
					UOC:FPB, FPA, ABC, LTG	

Section II.

ARMY TM 9-6115-670-14&P

(1) Item No	(2) SMR CODE	(3) NSN	(4) CAGEC	(5) Part Number	(6) Description and Usable on Code (UOC)	(7) QTY
					GROUP 010501 ENGINE;DIESEL, TURBO,3 CYLINDER, LIQUID COOLED	
					FIG C-8	
122	PAHZZA	2815-01-478-7489	OXWR1	16851-1511-0	PUSH ROD,ENGINE POP..... UOC:FPB,FPA,ABC,LTG	6
123	PAHZZA	2815-01-478-7487	OXWR1	16851-1555-0	TAPPET,ENGINE POPPE..... UOC:FPB,FPA,ABC,LTG	6
124	PAHZZA	2815-01-500-6968	OXWR1	16864-16010	CAMSHAFT,ENGINE.....	1
125	PAHZZA	3110-01-478-6106	OXWR1	15841-23250	COLLAR,BEARING..... UOC:FPB,FPA,ABC,LTG	1
126	PAHZZA	5331-01-478-4864	OXWR1	04811-16220	PACKING,PREFORMED..... UOC:FPB,FPA,ABC,LTG	1
127	PAHZZA	2815-01-479-0929	OXWR1	15881-2331-0	DEFLECTOR,DIRT AND..... UOC:FPB,FPA,ABC,LTG	1
128	PAHZZA	3020-01-479-0690	OXWR1	15841-2411-0	GEAR,HELICAL..... UOC:FPB,FPA,ABC,LTG	1
129	PAHZZA	2815-99-553-2023	S8029	16851-2111-2	PISTON..... UOC:FPA	3
129	PAHZZA	2815-99-500-2175	S8029	16851-2190-0	PISTON OVERSIZE, 0.5MM OVERSIZE, 0.5MM..... UOC:FPA	3
129	PAHZZA	2815-01-500-3916	OXWR1	16881-21110	PISTON,INTERNAL COM..... UOC:FPB,ABC,LTG	3
129	PAHZZA	2815-01-500-3928	OXWR1	16881-21900	PISTON,INTERNAL COM OVERSIZE, 0.5MM UOC:FPB,ABC,LTG	3
130	PAHZZA	2815-01-500-6905	OXWR1	16853-21050	RING,PISTON..... UOC:FPA	3
130	PAHZZA	2815-01-500-6967	OXWR1	16881-21050	RING,PISTON..... UOC:LTG,FPB,ABC	3
130	PAHZZA	2815-01-500-6878	OXWR1	16853-21090	RING,PISTON OVERSIZE,0.5MM..... UOC:FPA	3
130	PAHZZA	2815-01-500-6966	OXWR1	16881-21090	RING,PISTON OVERSIZE,0.5MM..... UOC:LTG,FPB,ABC	3
131	PAHZZA	5325-01-321-3445	OXWR1	15261-21330	RING,RETAINING..... UOC:FPB,FPA,ABC,LTG	6
132	PAHZZA	2815-01-479-0672	OXWR1	16851-2201-0	CONNECTING ROD,PIST SEE FIGURE C-16 FOR BREAKDOWN..... UOC:FPB,FPA,ABC,LTG	3
133	PAHZZA	2815-01-478-7493	OXWR1	16851-2131-0	PIN,PISTON..... UOC:FPB,FPA,ABC,LTG	3
135	PAHZZA	3120-01-478-6131	OXWR1	15861-23470	BEARING,SLEEVE..... UOC:FPB,FPA,ABC,LTG	1
135	PAHZZA	3120-01-478-6129	OXWR1	15861-23910	BEARING,SLEEVE UNDERSIZE, 0.2MM.... UOC:FPA	1
135	PAHZZA	3120-01-478-6128	OXWR1	15861-23920	BEARING,SLEEVE UNDERSIZE, 0.4MM.... UOC:FPA	1
135	PAHZZA	3120-01-478-6126	OXWR1	15861-23860	BEARING,SLEEVE UNDERSIZE, 0.2MM.... UOC:FPB,LTG	1
135	PAHZZA	3120-01-478-6125	OXWR1	15861-23870	BEARING,SLEEVE UNDERSIZE, 0.4MM.... UOC:FPB,LTG	1
136	PAHZZA	5306-01-479-0359	OXWR1	15841-04540	BOLT,MACHINE..... UOC:FPB,FPA,ABC,LTG	6
137	XBHZZA		OXWR1	16851-04040	CASE,MAIN BEARING..... UOC:FPA	1
137	XBHZZA		OXWR1	16881-04040	CASE,MAIN BEARING..... UOC:FPB,ABC,LTG	1

Section II.

ARMY TM 9-6115-670-14&P

(1) Item No	(2) SMR CODE	(3) NSN	(4) CAGEC	(5) Part Number	(6) Description and Usable on Code (UOC)	(7) QTY
GROUP 010501 ENGINE;DIESEL, TURBO,3 CYLINDER, LIQUID COOLED						
FIG C-8						
138	PAHZZA	5306-01-479-0360	OXWR1	15841-04562	BOLT,MACHINE..... UOC:FPA,ABC,LTG	2
139	PAHZZA	3120-01-478-6127	OXWR1	16861-23490	BEARING,SLEEVE..... UOC:FPA	2
139	PAHZZA	3120-01-478-6126	OXWR1	15861-23860	BEARING,SLEEVE UNDERSIZE, 0.2MM.... UOC:FPA	2
139	PAHZZA	3120-01-478-6125	OXWR1	15861-23870	BEARING,SLEEVE UNDERSIZE, 0.4MM.... UOC:FPA	2
139	PAHZZA	3120-01-500-8335	OXWR1	16689-23490	BEARING,SLEEVE..... UOC:FPA,ABC,LTG	2
139	PAHZZA	3120-01-500-8338	OXWR1	16881-23930	BEARING SET,SLEEVE UNDERSIZE, 0.2MM UOC:FPA,ABC,LTG	2
139	PAHZZA	3120-01-500-8349	OXWR1	16881-23940	BEARING SET,SLEEVE UNDERSIZE, 0.4MM UOC:FPA,ABC,LTG	2
140	XBHZZA		OXWR1	16861-04050	CASE,MAIN BEARING..... UOC:FPA	1
140	XBHZZA		OXWR1	16881-04050	CASE,MAIN BEARING..... UOC:FPA,ABC,LTG	1
141	XBHZZA		OXWR1	16851-04092	CASE,MAIN BEARING..... UOC:FPA	1
141	XBHZZA		OXWR1	16881-04090	CASE,MAIN BEARING..... UOC:FPA,ABC,LTG	1
142	PAHZZA	3120-01-478-6111	OXWR1	15261-23540	BEARING,WASHER,THRU..... UOC:FPA,ABC,LTG	2
142	PAHZZA	3120-01-478-6109	OXWR1	15261-23970	BEARING,WASHER,THRU OVERSIZE, 0.2MM UOC:FPA,ABC,LTG	2
142	PAHZZA	3120-01-478-6107	OXWR1	15261-23980	BEARING,WASHER,THRU OVERSIZE, 0.4MM UOC:FPA,ABC,LTG	2
143	PAHZZA	3120-01-478-6124	OXWR1	16861-23480	BEARING,SLEEVE..... UOC:FPA	1
143	PAHZZA	3120-01-478-6123	OXWR1	15694-23930	BEARING,SLEEVE UNDERSIZE, 0.2MM.... UOC:FPA	1
143	PAHZZA	3120-01-478-6120	OXWR1	15694-23940	BEARING,SLEEVE UNDERSIZE, 0.4MM.... UOC:FPA	1
143	PAHZZA	3120-01-500-8282	OXWR1	16689-23480	BEARING SET,SLEEVE..... UOC:FPA,LTG	1
143	PAHZZA	3120-01-500-8351	OXWR1	16881-23910	BEARING SET,SLEEVE UNDERSIZE, 0.2MM UOC:FPA,LTG	1
143	PAHZZA	3120-01-500-8344	OXWR1	16881-23920	BEARING SET,SLEEVE UNDERSIZE, 0.4MM UOC:FPA,ABC,LTG	1
144	PAHZZA	3120-01-478-6117	OXWR1	15261-23530	BEARING,WASHER,THRU..... UOC:FPA,ABC,LTG	2
144	PAHZZA	3120-01-478-6114	OXWR1	15261-23950	BEARING,WASHER,THRU OVERSIZE, 0.2MM UOC:FPA,ABC,LTG	2
144	PAHZZA	3120-01-478-6113	OXWR1	15261-23960	BEARING,WASHER,THRU OVERSIZE, 0.4MM UOC:FPA,ABC,LTG	2
145	PAHZZA	5306-01-321-3372	OXWR1	01023-50622	BOLT,MACHINE..... UOC:FPA,ABC,LTG	8
146	PAHZZA	2815-01-500-6974	OXWR1	16861-25010	FLYWHEEL,ENGINE..... UOC:FPA,ABC,LTG	1
147	PAHZZA	5306-01-485-8353	OXWR1	15852-25160	BOLT,MACHINE..... UOC:FPA,ABC,LTG	5
147A	XBHZZA		OXWR1	19666-04620	PLATE,REAR ENGINE..... UOC:FPA	1
147B	PAFZZA	5306-01-500-4266	OXWR1	01123-60816	BOLT,MACHINE..... UOC:FPA	10

Section II.

ARMY TM 9-6115-670-14&P

(1) Item No	(2) SMR CODE	(3) NSN	(4) CAGEC	(5) Part Number	(6) Description and Usable on Code (UOC)	(7) QTY
					GROUP 010501 ENGINE;DIESEL, TURBO,3 CYLINDER, LIQUID COOLED	
					FIG C-8	
148	PAHZZA	5330-01-478-6004	OXWR1	19215-99160	SEAL, PLAIN.....	1
					UOC:FPB, FPA, ABC, LTG	
149	PAHZZA	5306-01-321-3375	S4532	01023-50620	BOLT, MACHINE.....	8
					UOC:FPB, FPA, ABC, LTG	
150	XBHZZA		OXWR1	15841-04810	COVER, BEARING CASE.....	1
					UOC:FPB, FPA, ABC, LTG	
151	PAHZZA	5330-01-478-5159	OXWR1	15841-04822	GASKET.....	1
					UOC:FPB, FPA, ABC, LTG	
152	PAHZZA	5330-01-478-5156	OXWR1	15852-04360	GASKET.....	1
					UOC:FPB, FPA, ABC, LTG	
153	PAHZZA	2815-01-479-0604	OXWR1	16863-2301-0	CRANKSHAFT, ENGINE.....	1
					UOC:FPB, FPA, ABC, LTG	
154	XBHZZA		OXWR1	16881-01010	CRANKCASE, ENGINE.....	1
					UOC:FPA	
154	XBHZZA		OXWR1	16899-01010	CRANKCASE, ENG 903C.....	1
					UOC:FPB, ABC, LTG	
155	XBHZZA		OXWR1	05012-00508	PIN, DOWEL.....	2
					UOC:LTG, FPB, FPA, ABC	
156	XBFZZA		OXWR1	16851-96270	PLUG, EXPANSION.....	5
					UOC:FPB, FPA, ABC, LTG	
157	XBHZZA		OXWR1	16851-16212	COVER, CAMSHAFT.....	1
					UOC:FPB, FPA, ABC, LTG	
158	XBFZZA		OXWR1	15451-96270	PLUG, EXPANSION.....	2
					UOC:FPB, FPA, ABC, LTG	
159	XBFZZA		OXWR1	15261-96160	PLUG, SEALING.....	1
					UOC:FPB, FPA, ABC, LTG	
160	XBHZZA		OXWR1	05012-00814	PIN, DOWEL.....	2
					UOC:LTG, FPB, FPA, ABC	
161	XBFZZA		OXWR1	15521-96020	PLUG, PIPE.....	3
					UOC:FPB, FPA, ABC, LTG	
162	XBFZZA		OXWR1	15261-96010	PLUG, PIPE.....	5
					UOC:FPB, FPA, ABC, LTG	
163	XBFZZA		OXWR1	15521-96030	PLUG, PIPE.....	1
					UOC:FPB, FPA, ABC, LTG	
164	XBHZZA		OXWR1	15231-33960	NIPPLE, PIPE.....	2
					UOC:FPB, FPA, ABC, LTG	
165	XBFZZA		OXWR1	16851-96260	PLUG, EXPANSION.....	3
					UOC:FPB, FPA, ABC, LTG	
166	XBHZZA		OXWR1	17331-59190	NIPPLE, PIPE.....	2
					UOC:FPB, FPA, ABC, LTG	
167	PAFZZA	4820-01-479-0226	OXWR1	15841-7302-0	COCK, DRAIN.....	1
					UOC:FPA	
167	PAFZZA	4730-01-500-6151	OXWR1	15321-73340	BEND, PIPE, RETURN.....	1
					UOC:LTG, FPB, ABC	
168	PAHZZA	5331-01-478-5997	OXWR1	15221-33700	PACKING, PREFORMED.....	1
					UOC:LTG, FPB, FPA, ABC	
169	XBHZZA		OXWR1	15221-33650	NIPPLE, PIPE.....	1
					UOC:FPB, FPA, ABC, LTG	

End of Figure

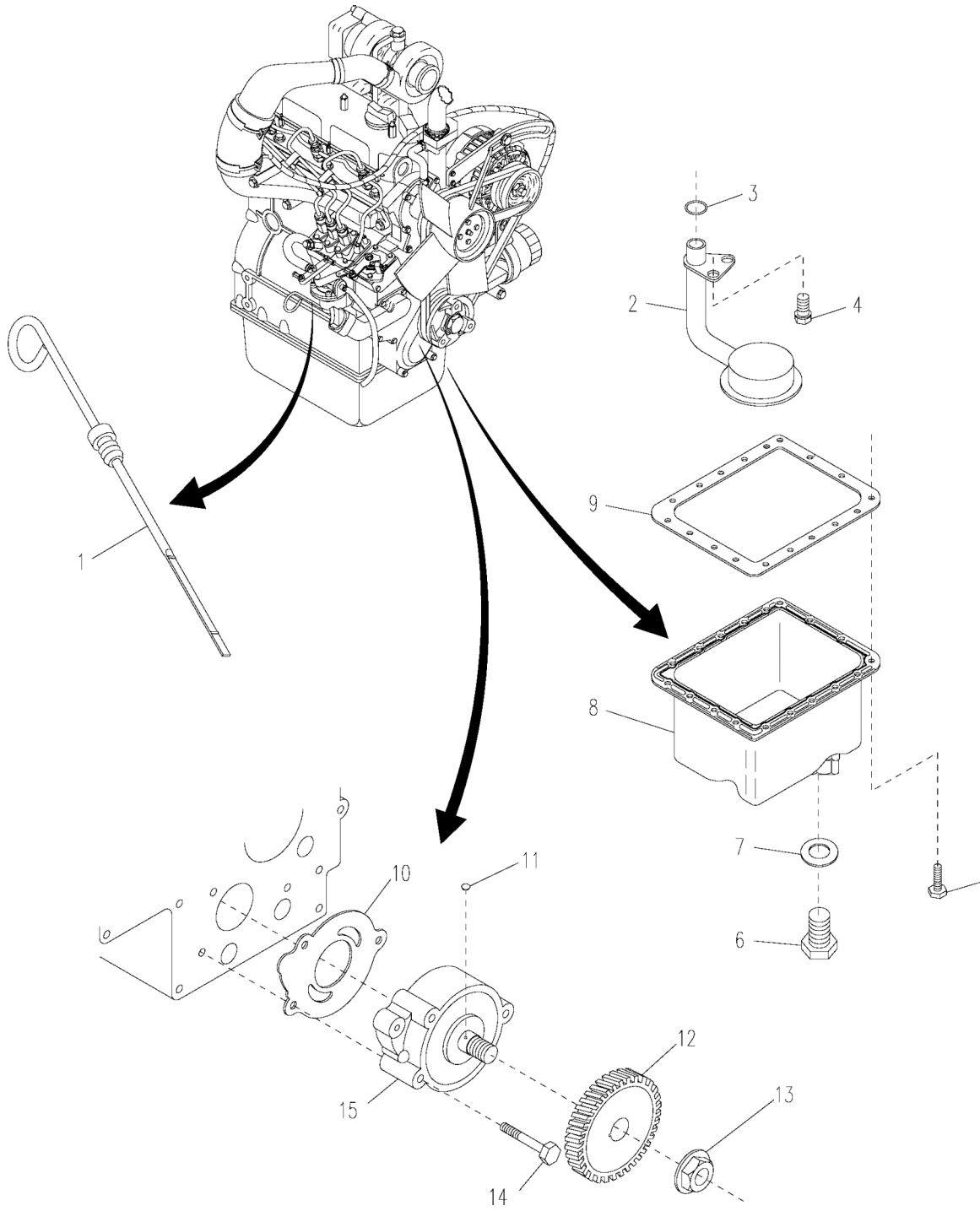

Figure C-9. Lubricating System (Sheet 1 of 2)

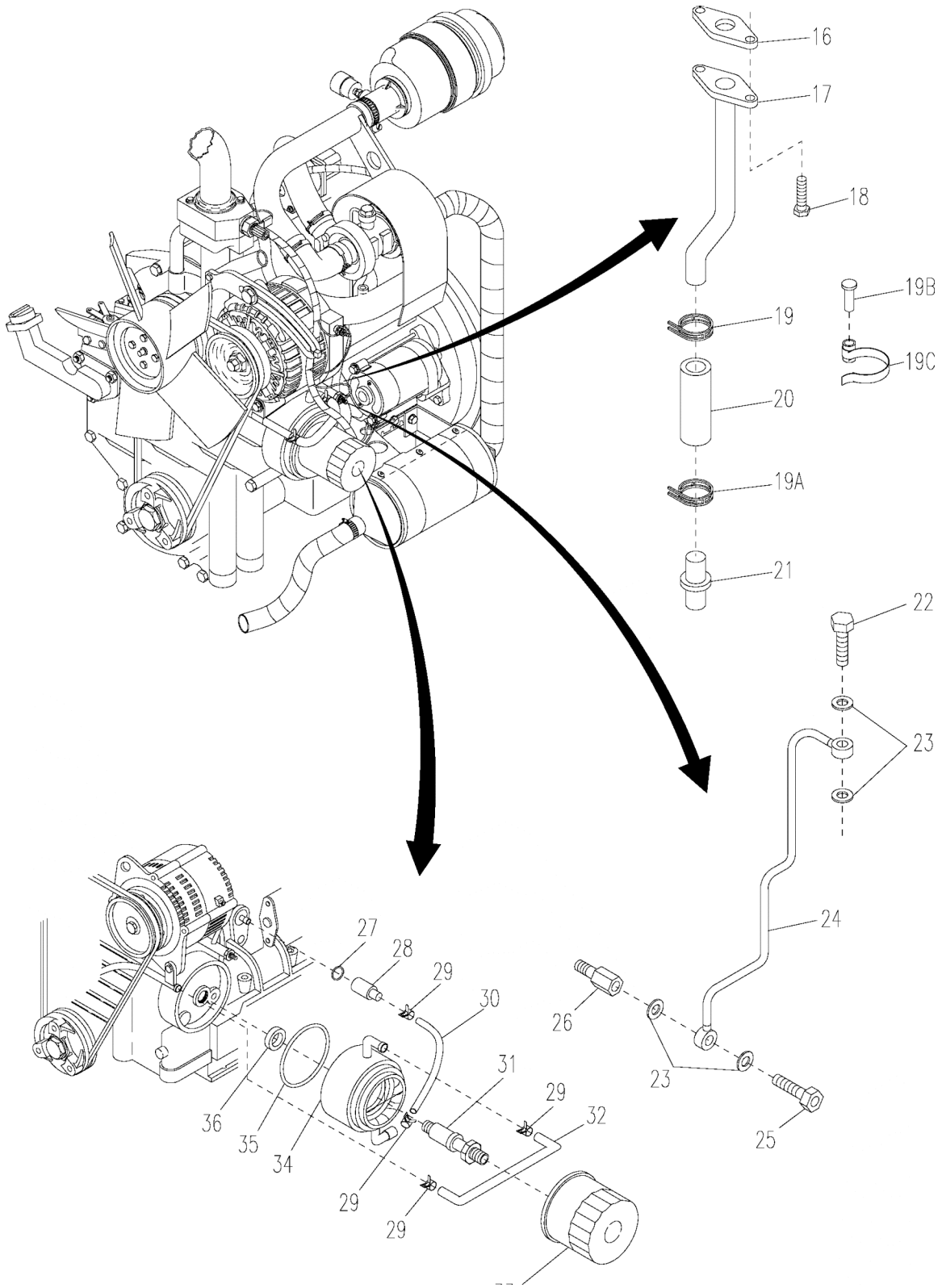

Figure C-9. Lubricating System (Sheet 2 of 2)

Section II.

ARMY TM 9-6115-670-14&P

(1) Item No	(2) SMR CODE	(3) NSN	(4) CAGEC	(5) Part Number	(6) Description and Usable on Code (UOC)	(7) QTY
GROUP 01050101 LUBRICATING SYSTEM						
FIG C-9						
1	PAFZZA	6680-01-500-6464	OXWR1	16851-36410	GAGE ROD, FLUID LEVE..... UOC: LTG, FPB, FPA, ABC	1
2	XBFZZA		OXWR1	16851-32110	PICKUP, OIL..... UOC: FPB, FPA, ABC, LTG	1
3	PAFZZA	2815-01-439-4961	67271	322035	GUARD, DIESEL ENGINE..... UOC: FPB, FPA, ABC, LTG	1
4	PAFZZA	5306-01-500-4262	OXWR1	01123-60814	BOLT, MACHINE..... UOC: FPB, FPA, ABC, LTG	1
5	PAFZZA	5306-01-321-3371	S4532	01023-50612	BOLT, MACHINE.....	18
6	PAOZZA	4730-01-434-3875	67271	322084	PLUG, PIPE..... UOC: FPB, FPA, ABC, LTG	1
7	PAOZZA	2990-01-438-8808	OXWR1	15451-96670	PLUG, GENERATOR..... UOC: FPB, FPA, ABC, LTG	1
8	XBFZZA		OXWR1	16863-01500	OIL PAN..... UOC: FPB, FPA, ABC, LTG	1
9	PAFZZA	5330-01-478-5112	31013	16266-01620	GASKET..... UOC: LTG, FPB, FPA, ABC	1
10	PAHZZA	5330-01-478-6354	OXWR1	16851-35152	GASKET..... UOC: FPB, FPA, ABC, LTG	1
11	PAHZZA	5315-01-486-1942	OXWR1	05712-00408	KEY, WOODRUFF..... UOC: FPB, FPA, ABC, LTG	1
12	PAHZZA	3020-01-486-7671	OXWR1	15841-35660	GEAR, HELICAL..... UOC: FPB, FPA, ABC, LTG	1
13	PAHZZA	5310-01-478-5170	OXWR1	02783-50100	NUT, PLAIN, HEXAGON..... UOC: FPB, FPA, ABC, LTG	1
14	PAHZZA	5306-01-479-0327	OXWR1	15841-91050	BOLT, MACHINE..... UOC: LTG, FPB, FPA, ABC	3
15	PAHZZA	2815-99-457-4475	S8029	16851-3501-0	OIL PUMP ASSEMBLY, E..... UOC: FPB, FPA, ABC, LTG	1
16	PAOZZA	5330-01-478-5144	OXWR1	16299-33670	GASKET..... UOC: FPB, FPA, ABC, LTG	1
17	XBOZZA		OXWR1	16881-33220	TUBE, OIL RETURN..... UOC: FPB, FPA, ABC, LTG	1
18	PAHZZA	5306-01-321-3375	S4532	01023-50620	BOLT, MACHINE..... UOC: FPB, FPA, ABC, LTG	2
19	PAOZZA	4730-01-478-7123	OXWR1	09318-88200	CLAMP, HOSE..... UOC: FPB, FPA, ABC, LTG	1
19A	PAFZZA	4730-01-501-2800	OXWR1	09318-88180	CLAMP, HOSE..... UOC: FPB, FPA, ABC, LTG	1
19B	PAFZZA	5315-01-500-4981	OXWR1	33430-82760	PIN, BAND..... UOC: FPB, FPA, ABC, LTG	1
19C	PAFZZA	5340-01-500-5929	OXWR1	15441-33520	CLAMP, LOOP..... UOC: FPB, FPA, ABC, LTG	1
20	PAFZZA	4720-01-500-6484	OXWR1	16881-33242	HOSE, NONMETALLIC..... UOC: FPB, FPA, ABC, LTG	1
21	XBOZZA		OXWR1	16881-33230	FITTING, HOSE..... UOC: FPB, FPA, ABC, LTG	1
22	XBFZZA		OXWR1	16241-95800	BOLT, OIL FITTING..... UOC: FPB, FPA, ABC, LTG	1
23	XBOZZA		OXWR1	15471-96650	GASKET, WASHER..... UOC: FPB, FPA, ABC, LTG	4
24	XBOZZA		OXWR1	16881-33210	TUBE, OIL SUPPLY..... UOC: FPB, FPA, ABC, LTG	1
25	XBOZZA		OXWR1	16241-33360	REDUCER, OIL FITTING..... UOC: FPB, FPA, ABC, LTG	1
26	XBOZZA		OXWR1	16881-33370	FITTING, OIL SUPPLY..... UOC: FPB, FPA, ABC, LTG	1

Section II.

ARMY TM 9-6115-670-14&P

(1) Item No	(2) SMR CODE	(3) NSN	(4) CAGEC	(5) Part Number	(6) Description and Usable on Code (UOC)	(7) QTY
GROUP 01050101 LUBRICATING SYSTEM						
FIG C-9						
27	PAOZZA	5331-01-478-5115	0XWR1	16881-96750	O-RING..... UOC:FPB,FPA,ABC,LTG	1
29	PAOZZA	4730-01-478-7130	0XWR1	16241-73360	CLAMP,HOSE..... UOC:FPB,FPA,ABC,LTG	4
30	PAFZZA	4720-01-500-6507	0XWR1	16881-37160	HOSE, PREFORMED..... UOC:FPA	1
30	PAFZZA	4720-01-500-6506	0XWR1	16899-37162	HOSE, PREFORMED..... UOC:LTG,FPB,ABC	1
31	XBOZZA		0XWR1	16899-37080	MOUNT,OIL FILTER..... UOC:FPA	1
31	XBFZZA		0XWR1	16241-37080	MOUNT,OIL FILTER..... UOC:LTG,FPB,ABC	1
32	PAFZZA	4720-01-500-6495	0XWR1	16881-37152	HOSE, PREFORMED..... UOC:FPA	1
32	PAFZZA	4720-01-500-6504	0XWR1	16899-37152	HOSE, PREFORMED..... UOC:FPB,ABC,LTG	1
33	PAFZZA	2940-01-500-6490	1Q0C4	70000-15241	FILTER ELEMENT,FLUI..... UOC:LTG,FPB,FPA,ABC	1
34	PAFZZA	2930-01-500-8979	0XWR1	16299-37010	COOLER,LUBRICATING..... UOC:FPA	1
34	PAFZZA	2930-01-500-8981	0XWR1	16881-37010	COOLER,LUBRICATING..... UOC:FPB,ABC,LTG	1
35	PAOZZA	5331-01-478-4871	0XWR1	04814-50600	O-RING..... UOC:LTG,FPB,FPA,ABC	1
36	XBFZZA		0XWR1	16241-37200	SPACER..... UOC:FPA	1
36	XBFZZA		0XWR1	16881-37200	SPACER..... UOC:LTG,FPB,ABC	1

End of Figure

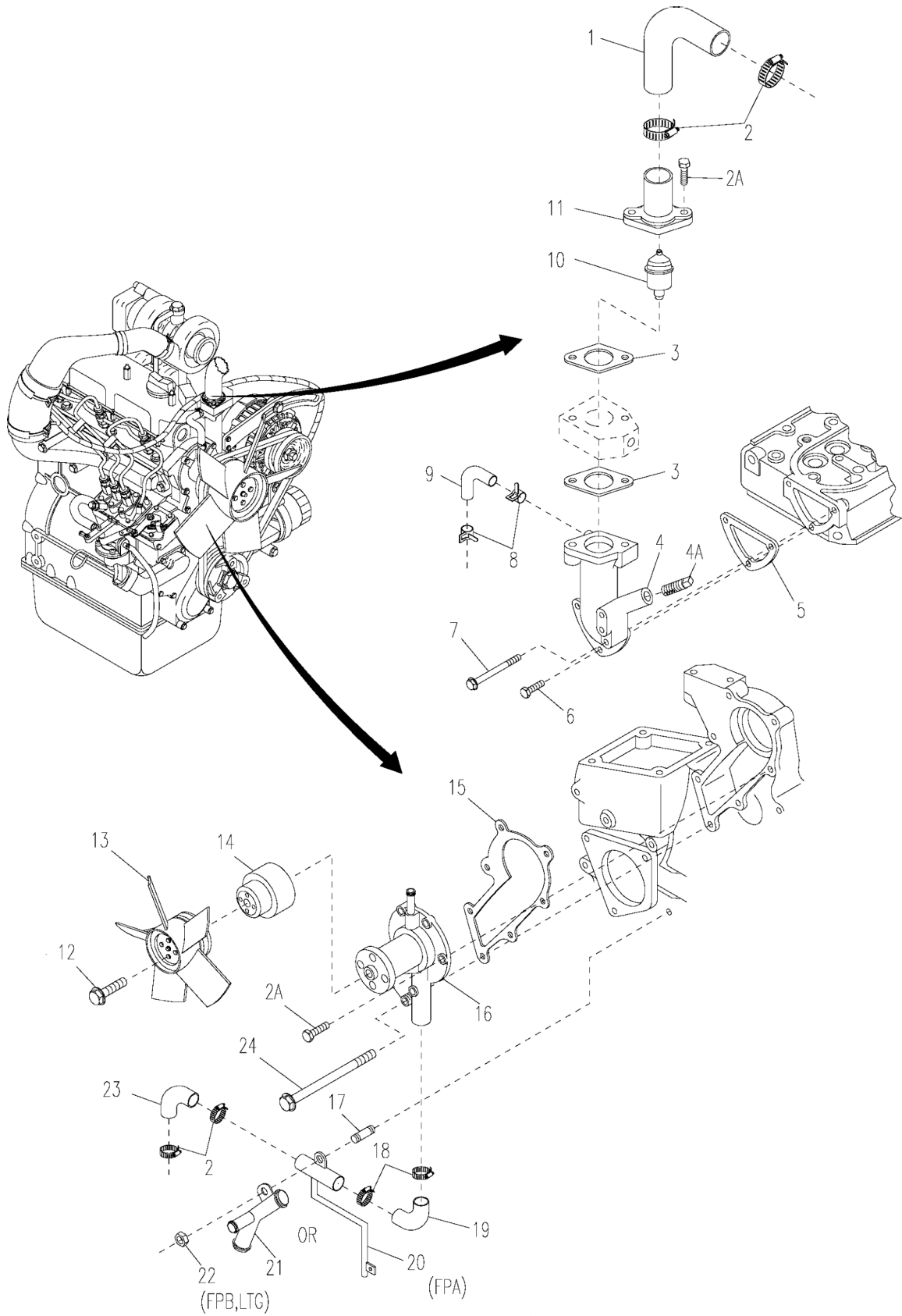

Figure C-10. Cooling System

Section II.

ARMY TM 9-6115-670-14&P

(1) Item No	(2) SMR CODE	(3) NSN	(4) CAGEC	(5) Part Number	(6) Description and Usable on Code (UOC)	(7) QTY
GROUP 01050102 COOLING SYSTEM						
FIG C-10						
1	PAOZZA	4720-01-478-6491	97403	13230E6330	HOSE, PREFORMED. UOC: FPB, FPA, ABC, LTG	1
2	PAOZZA	4730-01-470-2409	30554	88-20561-2	CLAMP, HOSE. UOC: LTG, FPB, ABC	4
2	PAFZZA	4730-01-500-5577	29381	1741008A	CLAMP, HOSE. UOC: FPA	4
2A	PAHZZA	5306-01-321-3372	0XWR1	01023-50622	BOLT, MACHINE. UOC: LTG, FPB, FPA, ABC	6
3	PAFZZA	5330-01-437-1059	0XWR1	15676-73270	GASKET. UOC: LTG, FPB, FPA, ABC	2
4	XBHZZA		0XWR1	16873-72700	FLANGE, WATER ENGINE. UOC: LTG, FPB, FPA, ABC	1
4A	PAFZZA	4730-01-496-6336	S4532	19298-9602-0	PLUG, MACHINE THREAD. UOC: FPB, FPA, ABC, LTG	1
5	PAFZZA	5330-01-478-5146	0XWR1	15841-72922	GASKET. UOC: FPB, FPA, ABC, LTG	1
6	XDOZZA		S4532	01023-50616	BOLT, MACHINE. UOC: FPB, FPA, ABC, LTG	2
7	PAFZZA	5306-01-479-0335	0XWR1	15891-91020	BOLT, MACHINE. UOC: FPB, FPA, ABC, LTG	1
8	PAOZZA	4730-01-478-7130	0XWR1	16241-73360	CLAMP, HOSE. UOC: FPB, FPA, ABC, LTG	2
9	PAOZZA	4720-01-478-7182	0XWR1	16851-73350	HOSE, PREFORMED. UOC: FPB, FPA, ABC, LTG	1
10	PAOZZA	2990-01-436-1329	0XWR1	19203-7301-0	SENSOR, ENGINE COOLA. UOC: FPB, FPA, ABC, LTG	1
11	XBFZZA		0XWR1	15841-73260	COVER, THERMOSTAT. UOC: FPB, FPA, ABC, LTG	1
12	PAOZZA	5306-01-393-4863	31013	01754-50610	BOLT, MACHINE. UOC: LTG, FPB, FPA, ABC	4
13	PAFZZA	4140-01-500-8094	0XWR1	19265-74110	FAN, CENTRIFUGAL. UOC: LTG, FPB, FPA, ABC	1
14	XBOZZA		0XWR1	15841-74250	PULLEY, FAN. UOC: LTG, FPB, FPA, ABC	1
15	PAFZZA	5330-01-500-3485	0XWR1	15881-73432	GASKET. UOC: LTG, FPB, FPA, ABC	1
16	XDOZZA		0XWR1	19883-7303-0	PUMP, COOLING SYSTEM. UOC: LTG, FPB, FPA, ABC	1
17	XBFZZA		0XWR1	15841-91510	STUD. UOC: LTG, FPB, FPA, ABC	1
18	PAOZZA	4730-01-478-7119	0XWR1	09318-89030	CLAMP, HOSE. UOC: LTG, FPB, FPA, ABC	2
19	PAOZZA	4720-01-478-7185	0XWR1	15881-72870	HOSE, PREFORMED. UOC: LTG, FPB, FPA, ABC	1
20	XBOZZA		0XWR1	16889-72860	PIPE, WATER. UOC: LTG, FPB, ABC	1
21	XBOZZA		0XWR1	16889-72860	PIPE, WATER. UOC: LTG, FPB, ABC	1
22	XDFZZA		0XWR1	02751-50060	NUT, PLAIN, PLATE. UOC: FPB, FPA, ABC, LTG	1
23	PAOZZA	4720-01-478-6494	97403	13230E6331	HOSE, PREFORMED. UOC: LTG, FPB, ABC	1
23	PAFZZA	4720-00-184-6241	81300	70646	HOSE, PREFORMED. UOC: FPA	1
24	PAOZZA	5306-01-479-0332	0XWR1	01203-50638	BOLT, MACHINE. UOC: LTG, FPB, FPA, ABC	1

End of Figure

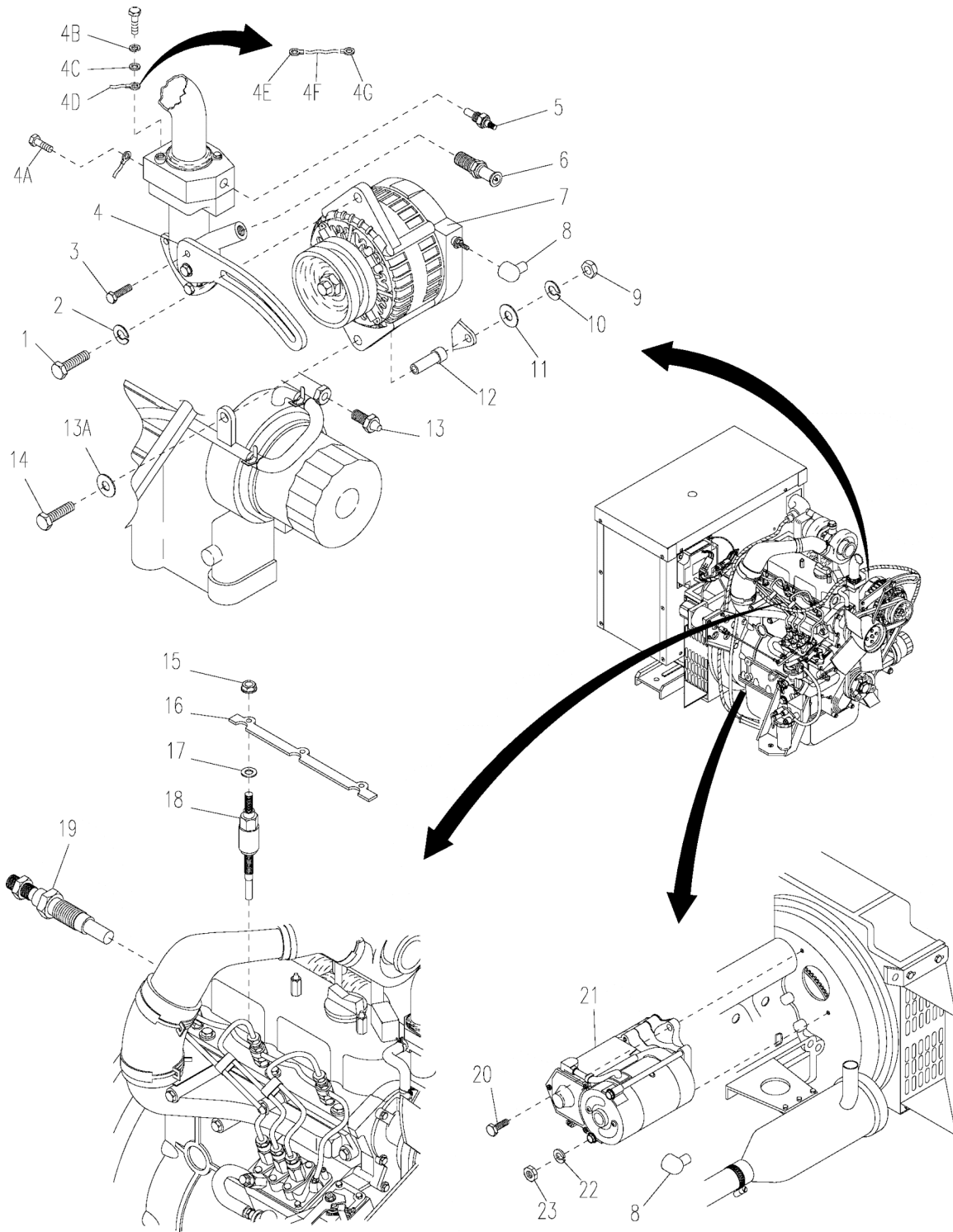

Figure C-11. Electrical System

Section II.

ARMY TM 9-6115-670-14&P

(1) Item No	(2) SMR CODE	(3) NSN	(4) CAGEC	(5) Part Number	(6) Description and Usable on Code (UOC)	(7) QTY
GROUP 01050103 ELECTRICAL SYSTEM						
FIG C-11						
1	PAFZZA	5306-01-500-4271	0XWR1	01123-50825	BOLT, MACHINE UOC:FPB,FPA,ABC,LTG	1
2	PAFZZA	5310-01-500-2384	0XWR1	04015-60080	WASHER, FLAT UOC:FPB,FPA,ABC,LTG	1
3	XDOZZA		0XWR1	01023-50616	BOLT, MACHINE UOC:FPB,FPA,ABC,LTG	2
4	XBOZZA		0XWR1	19883-64420	BRACE, ALTERNATOR UOC:FPB,FPA,ABC,LTG	1
4A	PAFZZA	5305-01-479-1846	97403	13218E0493-1287P	SCREW, MACHINE IIC UOC:LTG,FPB,ABC	1
4B	PAFZZA	5310-01-500-2424	97403	13230E6744-41	WASHER, LOCK UOC:LTG	1
4C	PAFZZA	5310-01-500-2474	30554	88-20564-17	WASHER, FLAT UOC:LTG	1
4D	MFFZZA		97403	13230E6232-38	LEAD, ELECTRICAL UOC:LTG	1
4E	PAFZZA	5940-00-113-8184	96906	MS25036-150	TERMINAL, LUG UOC:LTG	1
4F	MFFZZA		97403	13230E6653-5-3IN CH	WIRE, ELECTRICAL MAKE FROM WIRE, ELECTRICAL (97403) 13230E6653-5;3 INCH UOC:LTG	1
4G	PAFZZA	5940-00-113-8179	98410	BB-837-06	TERMINAL, LUG UOC:LTG	1
5	PAOZZA	6685-01-442-2395	59197	323-421	TRANSMITTER, TEMPERA UOC:FPB,FPA,ABC,LTG	1
6	PAOZZA	2990-01-478-6492	97403	13230E6320	SWITCH, ENGINE TEMPE UOC:FPB,FPA,ABC,LTG	1
7	PAFZZA	2920-01-500-6520	0XWR1	19883-64010	GENERATOR, ENGINE AC UOC:FPB,FPA,ABC,LTG	1
8	XBOZZA		97403	13230E6336	BOOT, ELEC UOC:FPB,ABC,LTG	2
9	PAFZZA	5310-01-500-2378	0XWR1	02176-50100	NUT, PLAIN, HEXAGON UOC:FPB,FPA,ABC,LTG	1
10	PAFZZA	5310-01-500-2376	0XWR1	04512-60100	WASHER, LOCK UOC:FPB,FPA,ABC,LTG	1
11	PAFZZA	5310-01-500-2379	0XWR1	04011-50100	WASHER, FLAT UOC:FPB,FPA,ABC,LTG	1
12	PAOZZA	5365-01-485-9244	0XWR1	19837-64372	SPACER, RING UOC:FPB,FPA,ABC,LTG	1
13	PAFZZA	5930-01-391-8105	0XWR1	15841-39010	SWITCH, PRESSURE UOC:FPB,FPA,ABC,LTG	1
13A	PAFZZA	5310-01-500-2382	0XWR1	04013-60100	WASHER, FLAT UOC:FPB,FPA,ABC,LTG	1
14	PAFZZA	5306-01-500-8697	0XWR1	01173-51090	BOLT, MACHINE UOC:FPB,FPA,ABC,LTG	1
15	PAOZZA	5310-01-440-6749	0XWR1	02761-50040	NUT, PLAIN, HEXAGON UOC:FPB,FPA,ABC,LTG	3
16	XBOZZA		0XWR1	16861-65560	JUMPER, STRAP UOC:FPB,FPA,ABC,LTG	1
17	PAOZZA	5310-01-478-5116	0XWR1	04013-60040	WASHER, FLAT UOC:FPB,FPA,ABC,LTG	3
18	PAFZZA	2920-01-478-7511	0XWR1	16881-65512	GLOW PLUG UOC:FPB,FPA,ABC,LTG	3
19	PAOZZA	2920-01-479-1725	97403	13230E6339	GLOW PLUG UOC:FPB,FPA,ABC,LTG	1

Section II.

ARMY TM 9-6115-670-14&P

(1) Item No	(2) SMR CODE	(3) NSN	(4) CAGEC	(5) Part Number	(6) Description and Usable on Code (UOC)	(7) QTY
GROUP 01050103 ELECTRICAL SYSTEM						
FIG C-11						
20	PAOZZA	5306-01-479-0338	0XWR1	01153-50828	BOLT, MACHINE..... UOC:FPB,FPA,ABC,LTG	2
21	PAOZZA	2925-14-497-4269	0XWR1	19883-63010	BOUGIE, SPECIAL..... UOC:FPB,FPA,ABC,LTG	1
22	PAFZZA	5310-01-321-3477	0XWR1	04512-60080	WASHER, LOCK..... UOC:FPB,FPA,ABC,LTG	3
23	PAOZZA	5310-01-320-7060	0XWR1	02114-50080	NUT, PLAIN, HEXAGON..... UOC:FPB,FPA,ABC,LTG	1

End of Figure

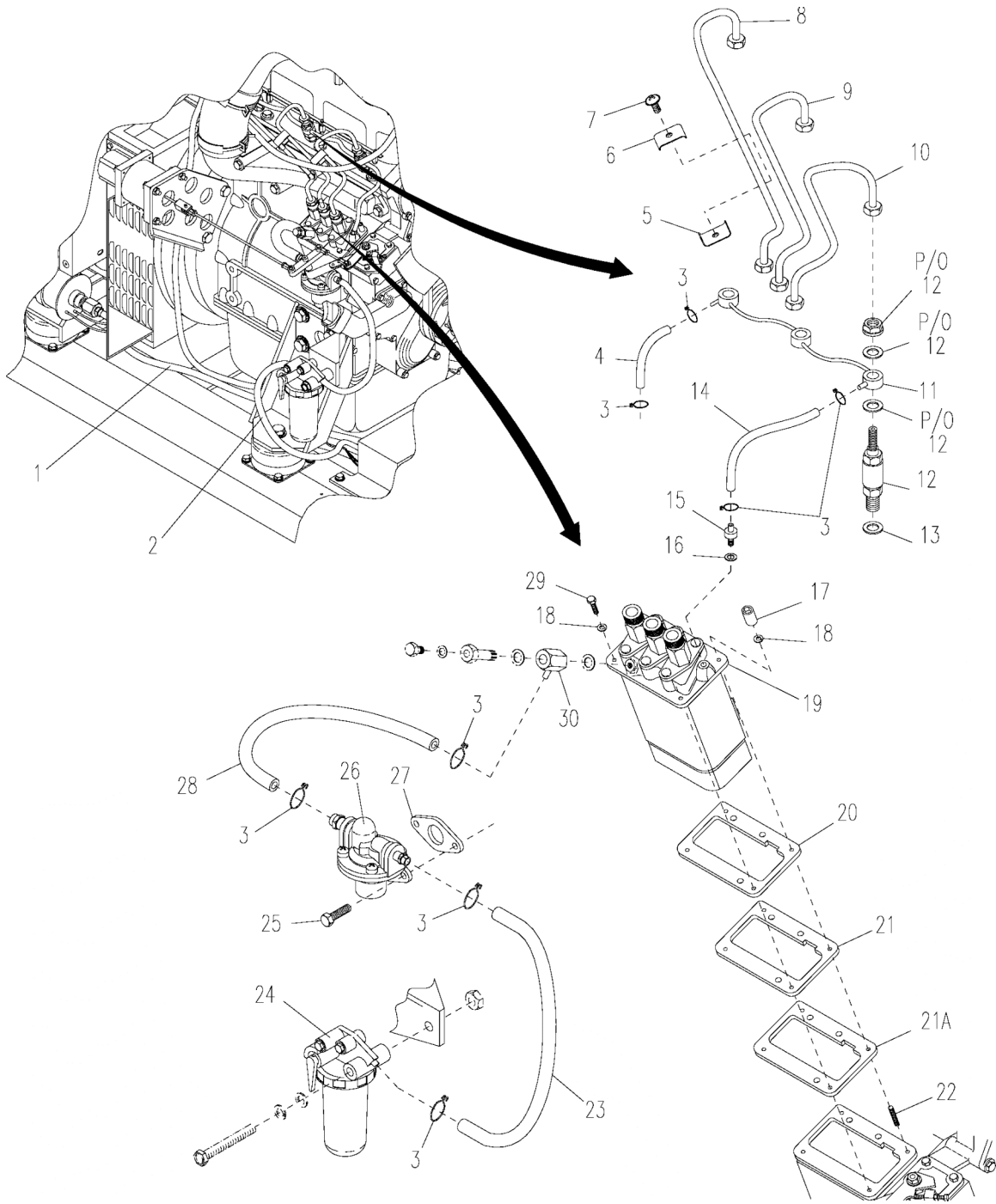

Figure C-12. Fuel System

Section II.

ARMY TM 9-6115-670-14&P

(1) Item No	(2) SMR CODE	(3) NSN	(4) CAGEC	(5) Part Number	(6) Description and Usable on Code (UOC)	(7) QTY
GROUP 01050104 FUEL SYSTEM						
FIG C-12						
1	MOOZZA		30554	88-20579-4-20INC H	HOSE, NONMETALLIC MAKE FROM HOSE, NONMETALLIC P/N (30554) 88-20579-4; INCHES..... UOC: FPB, ABC, LTG	1
2	MOOZZA		30554	88-20579-4-15INC H	HOSE, NONMETALLIC MAKE FROM HOSE, NONMETALLIC P/N (30554) 88-20579-4; INCHES..... UOC: FPB, ABC, LTG	1
3	PAOZZA	4730-01-470-1626	30554	88-20561-1	CLAMP, HOSE..... UOC: FPB, ABC, LTG	12
3	XDOZZA		81646	6340	CLAMP, HOSE..... UOC: FPA	6
4	MOOZZA		30554	88-20579-2-20INC H	HOSE, NONMETALLIC MAKE FROM HOSE, NONMETALLIC P/N (30554) 88-20579-2; INCHES..... UOC: FPB, ABC, LTG	1
5	XBOZZA		67271	322135	CLAMP, HOSE, SPECIAL-..... UOC: FPB, FPA, ABC, LTG	2
6	XBOZZA		67271	322136	CLAMP, HOSE, SPECIAL-..... UOC: FPB, FPA, ABC, LTG	2
7	PAOZZA	2590-01-438-8872	67271	322026	COMPONENT, SCREW..... UOC: FPB, FPA, ABC, LTG	2
8	XBOZZA		0XWR1	16861-53732	PIPE, INJECTOR..... UOC: FPB, FPA, ABC, LTG	1
9	XBFZZA		0XWR1	16851-53722	PIPE, INJECTOR..... UOC: FPB, FPA, ABC, LTG	1
10	XBOZZA		0XWR1	16851-53712	PIPE, INJECTOR..... UOC: FPB, FPA, ABC, LTG	1
11	XBFZZA		0XWR1	15862-42502	OVERFLOW PIPE ASSY..... UOC: FPB, FPA, ABC, LTG	1
12	PAFZZA	2910-01-500-8991	0XWR1	16001-53000	NOZZLE, FUEL INJECTI..... UOC: FPB, FPA, ABC, LTG	3
13	PAFZZA	5331-01-431-3621	0XWR1	15841-53622	O-RING..... UOC: FPB, FPA, ABC, LTG	3
14	MOOZZA		30554	88-20579-2-7INCH	HOSE, NONMETALLIC MAKE FROM HOSE, NONMETALLIC P/N (30554) 88-20579-2, NCHES..... UOC: FPB, ABC, LTG	1
15	PAOZZA	2910-01-439-4915	67271	322123	AIR BREATHER..... UOC: FPB, FPA, ABC, LTG	1
16	PAOZZA	5330-01-478-4911	0XWR1	15601-96650	GASKET..... UOC: FPB, FPA, ABC, LTG	1
17	PAFZZA	5310-01-478-5173	0XWR1	15841-92320	NUT, PLAIN, CAP..... UOC: FPB, FPA, ABC, LTG	2
18	PAHZZA	5310-01-320-7100	0XWR1	04512-60060	WASHER, LOCK..... UOC: FPB, FPA, ABC, LTG	4
19	PAFFAA	2915-01-494-3004	0XWR1	16006-51010	INJECTION CONTROL, M SEE FIGURE C-13 FOR BREAKDOWN..... UOC: FPB, FPA, ABC, LTG	1
20	PAFZZA	5365-01-437-1065	0XWR1	16006-52092	SHIM, INJECTION..... UOC: FPB, FPA, ABC, LTG	1
21	PAFZZA	5365-01-437-1064	0XWR1	16006-52112	SHIM, INJECTION..... UOC: FPB, FPA, ABC, LTG	1
21A	PAFZZA	5365-01-500-3332	0XWR1	16006-52122	SHIM..... UOC: FPB, FPA, ABC, LTG	1
22	PAFZZA	5307-01-477-2256	1Q0C4	15841-91500	STUD, PLAIN..... UOC: FPB, FPA, ABC, LTG	2

Section II.

ARMY TM 9-6115-670-14&P

(1) Item No	(2) SMR CODE	(3) NSN	(4) CAGEC	(5) Part Number	(6) Description and Usable on Code (UOC)	(7) QTY
GROUP 01050104 FUEL SYSTEM						
FIG C-12						
23	MOOZZA		30554	88-20579-4-7.5IN CH	HOSE, NONMETALLIC MAKE FROM HOSE, NONMETALLIC P/N (30554) 88-20579-4; INCHES.....	1
24	PAOOOA	2910-01-478-8822	0XWR1	19204-43010	UOC:FPB,ABC,LTG FILTER, FLUID SEE FIGURE C-14 FOR BREAKDOWN.....	1
25	XDOZZA		0XWR1	01023-50616	UOC:FPB,FPA,ABC,LTG BOLT, MACHINE.....	2
26	PAFZZA	2910-01-445-4934	0XWR1	15821-52030	UOC:FPB,FPA,ABC,LTG PUMP, FUEL, METERING.....	1
27	PAFZZA	5330-01-478-6366	0XWR1	16264-52140	UOC:FPB,FPA,ABC,LTG GASKET.....	1
28	MOOZZA		30554	88-20579-4-6INCH	UOC:FPB,FPA,ABC,LTG HOSE, NONMETALLIC MAKE FROM HOSE, NONMETALLIC P/N (30554) 88-20579-4; NCHES.....	1
29	PAFZZA	5306-01-479-0350	0XWR1	01311-10620	UOC:FPB,ABC,LTG BOLT, MACHINE.....	2
30	PAOZZA	4730-01-486-3468	0XWR1	15841-95680	UOC:FPB,FPA,ABC,LTG NUT, TUBE COUPLING, R.....	1

End of Figure

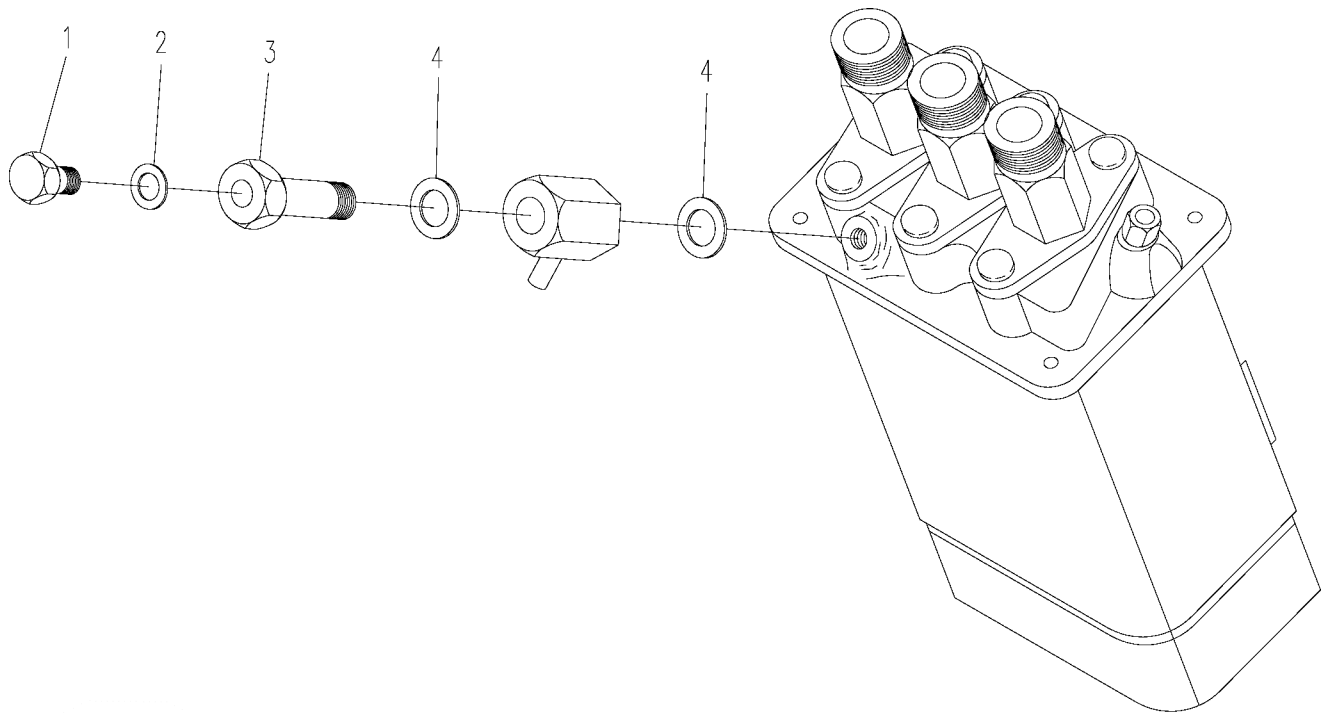

Figure C-13. Injector Pump

Section II.

ARMY TM 9-6115-670-14&P

(1) Item No	(2) SMR CODE	(3) NSN	(4) CAGEC	(5) Part Number	(6) Description and Usable on Code (UOC)	(7) QTY
					GROUP 0105010401 INJECTOR PUMP	
					FIG C-13	
1	PAFZZA	5305-01-480-1127	OXWR1	15841-51350	VALVE, BLEEDER, HYDRA..... UOC:FPB,FPA,ABC,LTG	1
2	PAFZZA	5330-01-478-4851	OXWR1	15841-96650	GASKET..... UOC:FPB,FPA,ABC,LTG	2
3	PAFZZA	4730-01-486-3490	OXWR1	15841-51320	BOLT, FLUID PASSAGE..... UOC:FPB,FPA,ABC,LTG	1
4	PAFZZA	5330-01-478-4849	OXWR1	15841-96660	GASKET..... UOC:FPB,FPA,ABC,LTG	1

End of Figure

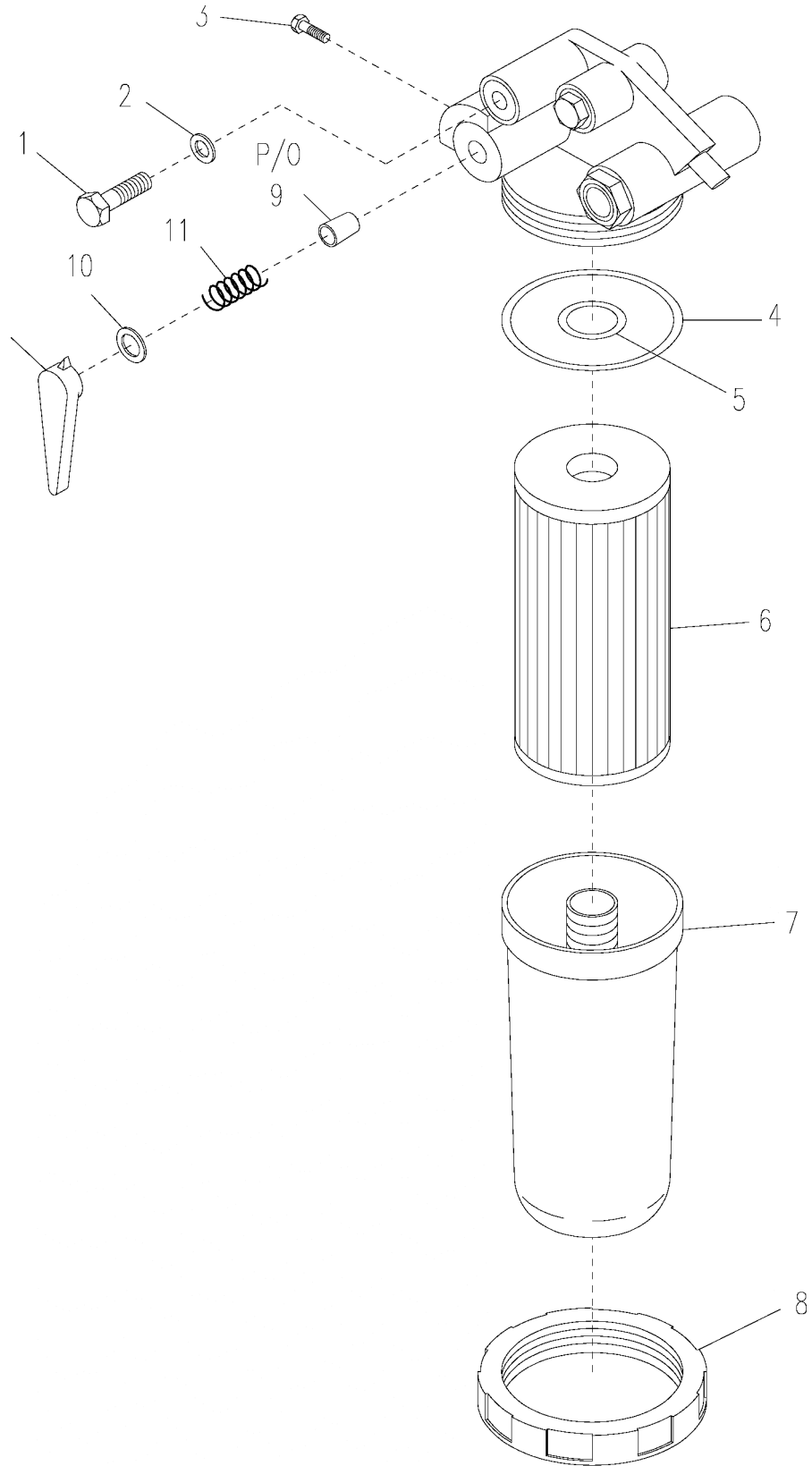

Figure C-14. Fuel Filter Assembly

Section II.

ARMY TM 9-6115-670-14&P

(1) Item No	(2) SMR CODE	(3) NSN	(4) CAGEC	(5) Part Number	(6) Description and Usable on Code (UOC)	(7) QTY
GROUP 0105010402 FUEL FILTER ASSEMBLY						
FIG C-14						
1	PAFZZA	5305-01-500-8417	0XWR1	19204-43280	SCREW, MACHINE UOC: FPB, FPA, ABC, LTG	2
2	PAOZZA	5331-01-325-5809	31013	04810-00060	O-RING UOC: FPB, FPA, ABC, LTG	2
3	PAOZZA	5305-01-320-7069	S4532	14301-4383-0	SCREW, MACHINE UOC: FPB, FPA, ABC, LTG	1
4	PAOZZA	5331-01-320-9567	S4532	04811-00390	O-RING UOC: FPB, FPA, ABC, LTG	1
5	PAFZZA	5331-01-320-9568	S4532	04811-00100	O-RING UOC: LTG, FPB, FPA, ABC	1
6	PAOZZA	2940-01-478-9487	0XWR1	15231-43560	FILTER ELEMENT, FLUI UOC: FPB, FPA, ABC, LTG	1
7	XBOZZA		0XWR1	15393-43580	CUP, FUEL FILTER UOC: FPB, FPA, ABC, LTG	1
8	XBOZZA		0XWR1	14301-43590	RING, RETAINING UOC: FPB, FPA, ABC, LTG	1
9	XBOZZA		0XWR1	14301-43522	LEVER, FUEL SHUTOFF UOC: FPB, FPA, ABC, LTG	1
10	PAOZZA	5331-01-320-9566	0XWR1	14301-43840	O-RING UOC: FPB, FPA, ABC, LTG	1
11	XBOZZA		0XWR1	14301-43820	SPRING, VALVE UOC: FPB, FPA, ABC, LTG	1

End of Figure

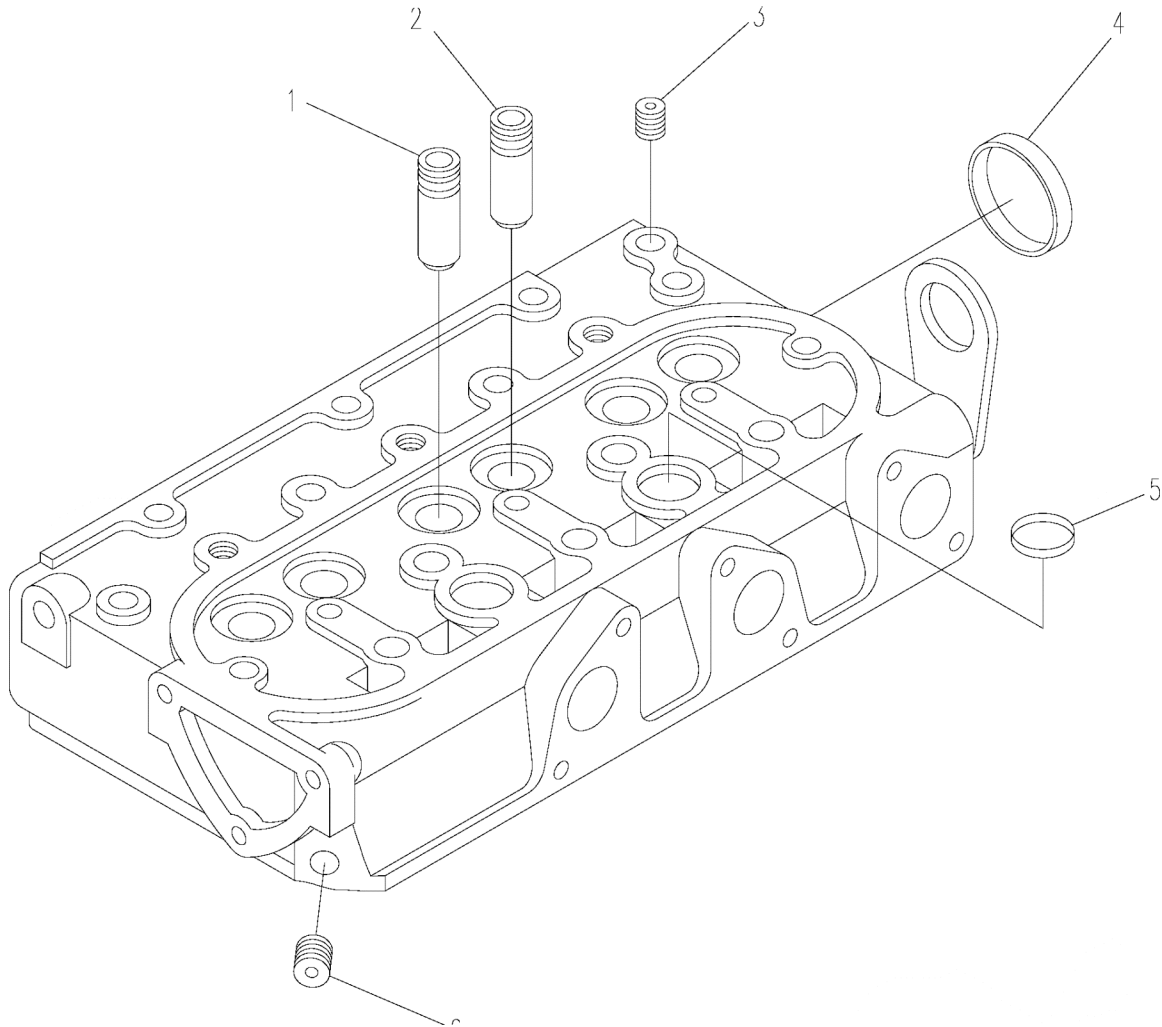

Figure C-15. Cylinder Head Assembly

Section II.

ARMY TM 9-6115-670-14&P

(1) Item No	(2) SMR CODE	(3) NSN	(4) CAGEC	(5) Part Number	(6) Description and Usable on Code (UOC)	(7) QTY
GROUP 01050105 CYLINDER HEAD ASSY						
FIG C-15						
1	XBHZZA		0XWR1	15841-13540	GUIDE, INTAKE VALVE..... UOC:FPB,FPA,ABC,LTG	3
2	XBHZZA		0XWR1	15841-13560	GUIDE, EXHAUST VALVE..... UOC:FPB,FPA,ABC,LTG	3
3	XBHZZA		0XWR1	15841-96020	PLUG, PIPE..... UOC:FPB,FPA,ABC,LTG	1
4	XBHZZA		0XWR1	15321-96260	PLUG, EXPANSION..... UOC:FPB,FPA,ABC,LTG	1
5	XBHZZA		0XWR1	15261-03370	PLUG, EXPANSION..... UOC:FPB,FPA,ABC,LTG	2
6	XBHZZA		0XWR1	15261-96010	PLUG, PIPE..... UOC:FPB,FPA,ABC,LTG	1

End of Figure

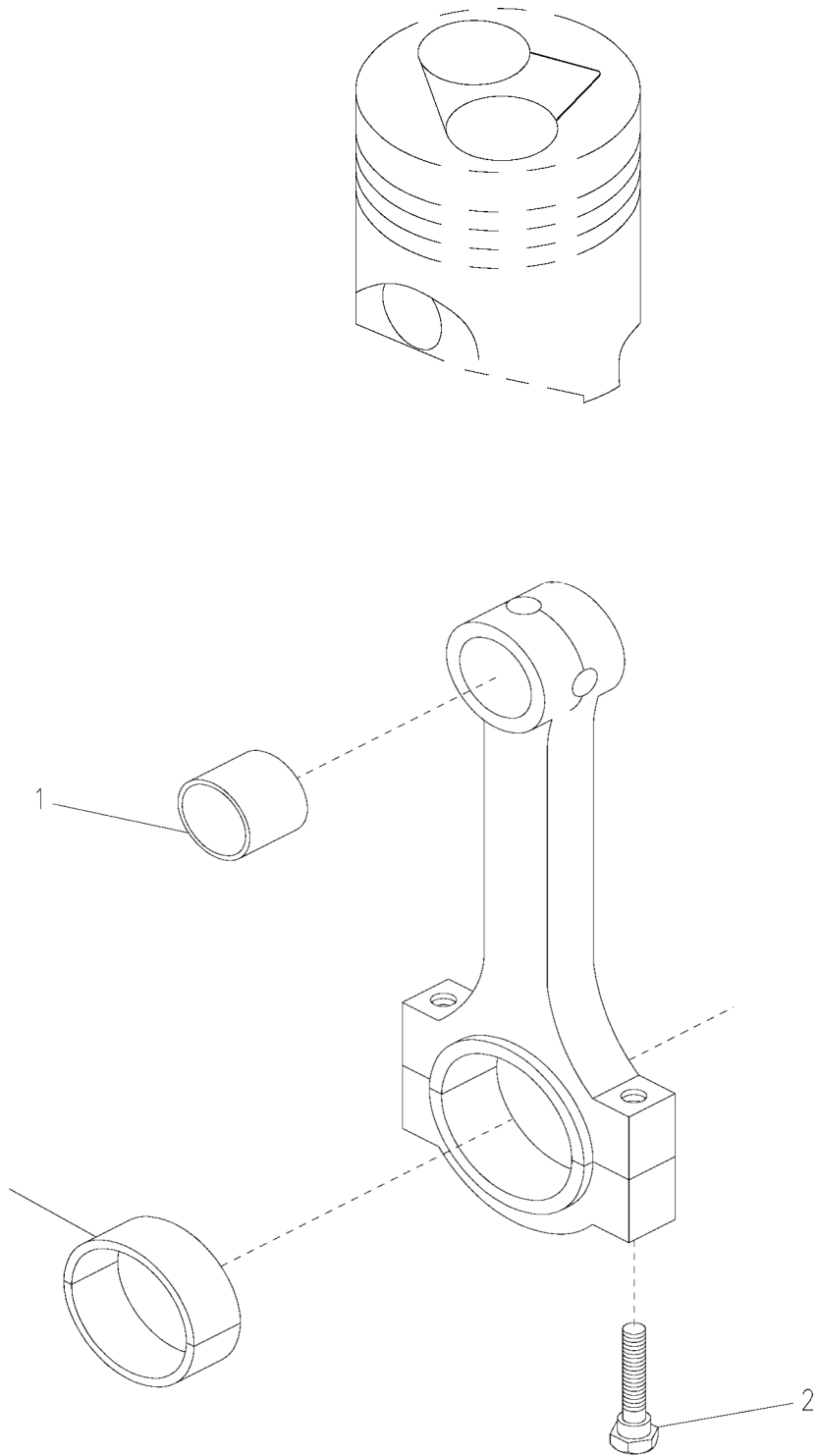

Figure C-16. Connecting Rod

Section II.

ARMY TM 9-6115-670-14&P

(1) Item No	(2) SMR CODE	(3) NSN	(4) CAGEC	(5) Part Number	(6) Description and Usable on Code (UOC)	(7) QTY
GROUP 01050106 CONNECTING ROD						
FIG C-16						
1	PAHZZA	3120-01-478-6138	OXWR1	16851-21980	BUSHING, SLEEVE..... UOC:FPB,FPA,ABC,LTG	3
2	PAHZZA	5306-01-479-0361	OXWR1	16851-22140	BOLT, MACHINE..... UOC:FPB,FPA,ABC,LTG	6
3	PAHZZA	3120-01-478-6137	OXWR1	16851-22320	BEARING, SLEEVE..... UOC:FPB,FPA,ABC,LTG	3
3	PAHZZA	3120-01-478-6135	OXWR1	15861-22970	BEARING, SLEEVE UNDERSIZE, 0.2MM.... UOC:FPB,FPA,ABC,LTG	3
3	PAHZZA	3120-01-478-6132	OXWR1	15861-22980	BEARING, SLEEVE UNDERSIZE, 0.4MM.... UOC:FPB,FPA,ABC,LTG	3

End of Figure

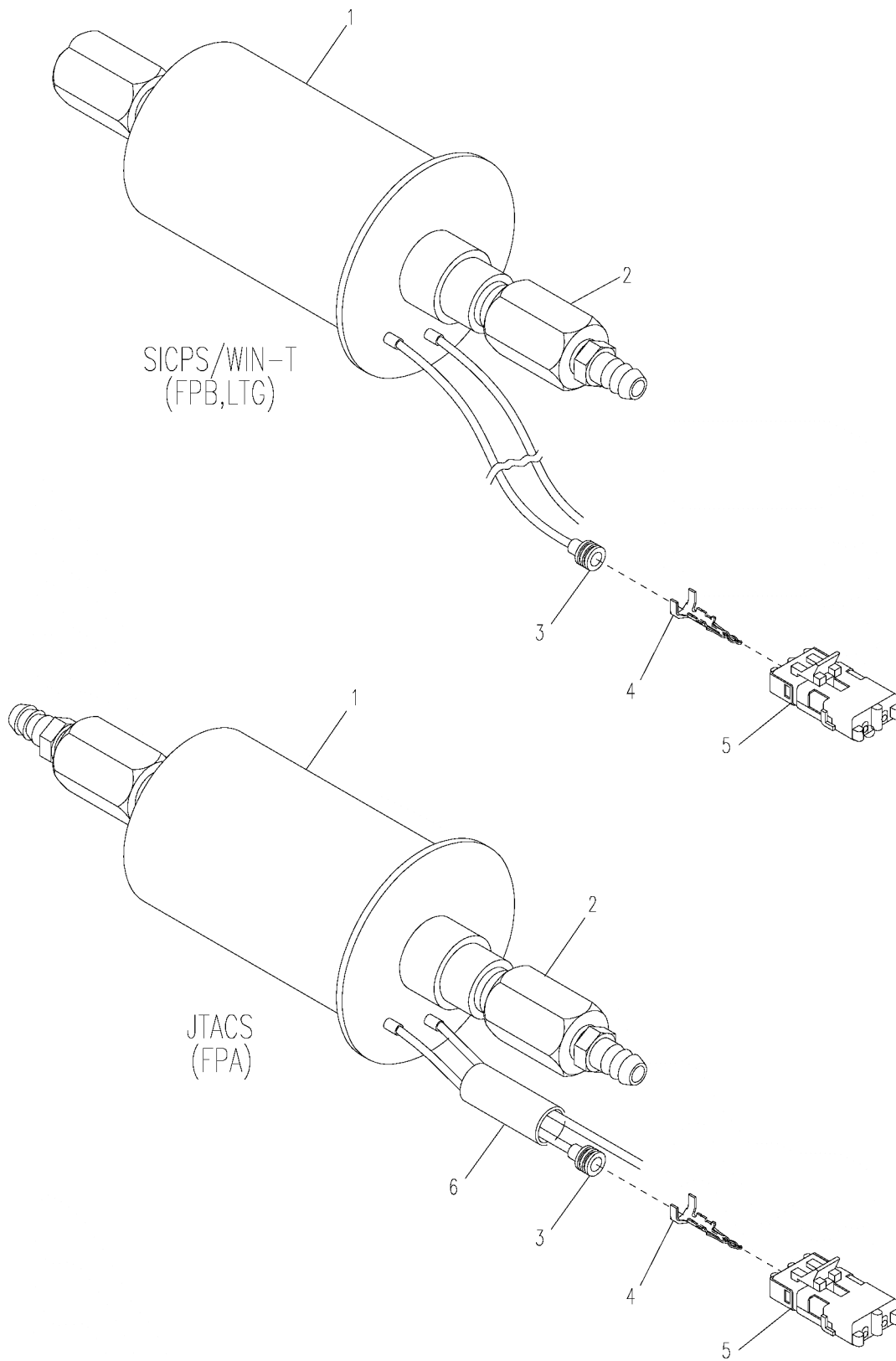

Figure C-17. Fuel Pump Assembly

Section II.

ARMY TM 9-6115-670-14&P

(1) Item No	(2) SMR CODE	(3) NSN	(4) CAGEC	(5) Part Number	(6) Description and Usable on Code (UOC)	(7) QTY
GROUP 0106 FUEL PUMP ASSEMBLE						
FIG C-17						
1	XBOZZA		97403	13230E6305	PUMP, FUEL, ELEC..... UOC:FPB, ABC, LTG	1
1	XBFZZA		29381	3127008A	PUMP, FUEL..... UOC:FPA	1
2	PAOZZA	4730-00-595-1721	93061	125HBL-5-4	ADAPTER, STRAIGHT, PI..... UOC:FPB, FPA, ABC, LTG	1
2	PAOZZA	4730-00-595-1721	93061	125HBL-5-4	ADAPTER, STRAIGHT, PI..... UOC:FPA	2
3	PAOZZA	5975-01-310-5011	77060	12015323	BOOT, DUST AND MOIST..... UOC:FPB, FPA, ABC, LTG	2
4	PAOZZA	5999-01-323-4929	77060	1208 9188	CONTACT, ELECTRICAL..... UOC:FPB, ABC, LTG	2
4	PAFZAA	5999-01-406-4110	77060	12124582	CONTACT, ELECTRICAL..... UOC:FPA	2
5	PAOZZA	5935-01-214-5259	77060	12015792	CONNECTOR BODY, PLUG..... UOC:LTG, FPB, FPA, ABC	1
5	PAFZZA	5935-01-214-4163	22785	12010973	CONNECTOR BODY, PLUG..... UOC:FPA	1
6	XBFZZA		29381	2219012A-6	TUBING, HEAT SHRINK..... UOC:FPA	1
7	MOOOZA		30554	88-20541-13	INSULATION SLEEVING MAKE FROM (28105) ST-301-3/8 BLACK OR (1JX75) B2 3/8 BLACK, 1 FOOT LONG..... UOC:ABC	1
8	MOOOZA		97403	13230E6973-19-12 INCH	BRAID, WIRE..... UOC:ABC	1
9	PAOZZA	5940-01-052-7646	14726	SO5300F	TERMINAL, QUICK DISC..... UOC:ABC	1
10	PAOZZA	5940-00-143-4773	81343	MS25036-105	TERMINAL, LUG..... UOC:ABC	1
11	PAOZZA	5940-00-143-4793	96906	MS25036-110	TERMINAL, LUG..... UOC:ABC	1
12	PAOZZA	4730-00-595-1721	93061	125HBL-5-4	ADAPTER, STRAIGHT, PI..... UOC:ABC	1

End of Figure

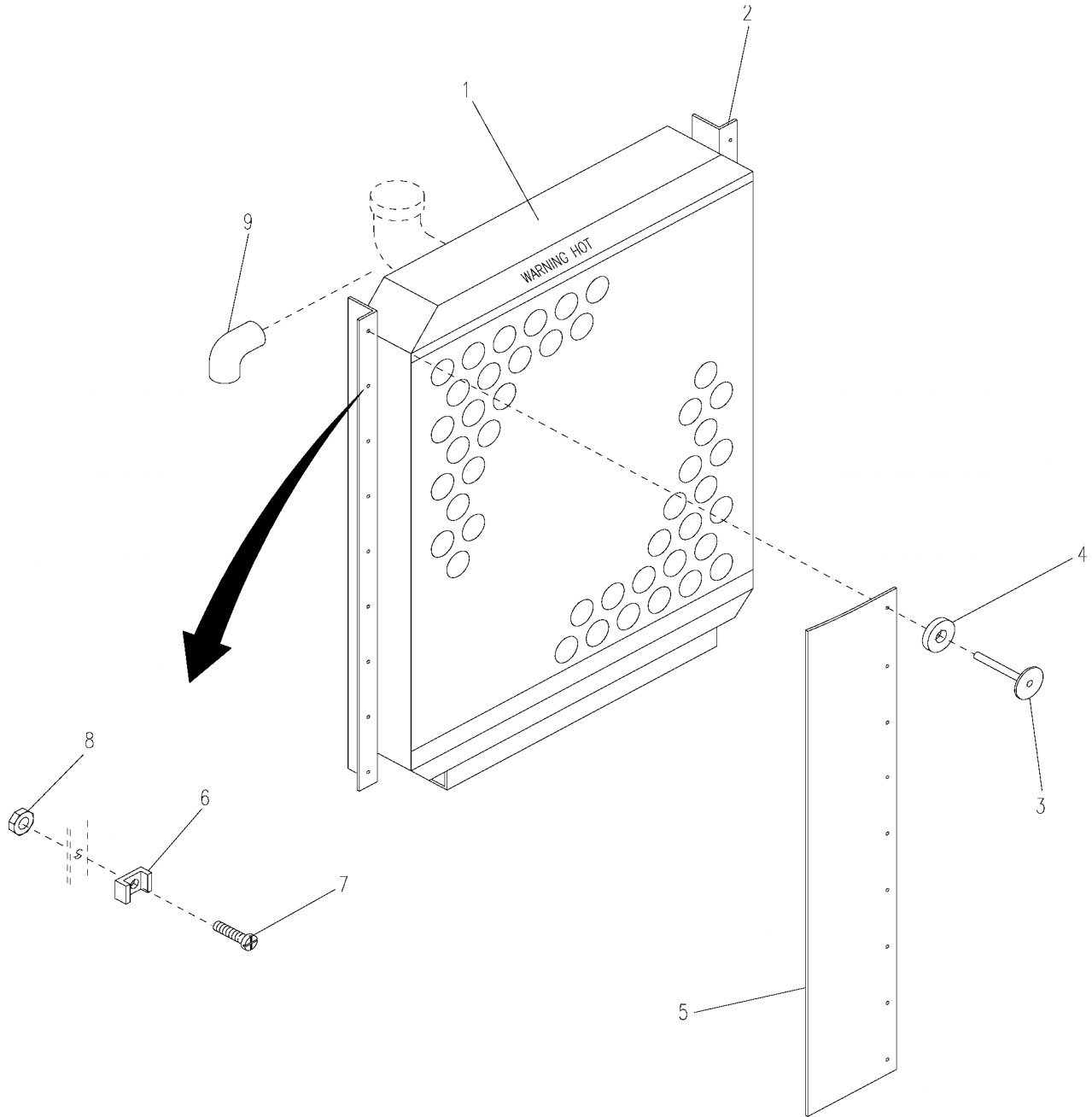

Figure C-18. Radiator Subassembly

Section II.

ARMY TM 9-6115-670-14&P

(1) Item No	(2) SMR CODE	(3) NSN	(4) CAGEC	(5) Part Number	(6) Description and Usable on Code (UOC)	(7) QTY
GROUP 0107 RADIATOR SUBASSEMBLY						
FIG C-18						
1	XBHZZA		97403	13230E6283	RADIATOR..... UOC:FPA, FPA, ABC, LTG	1
2	MHHZZA		97403	13230E6288-1	FARING, RADIATOR..... UOC:ABC, FPA	2
3	PAHZZA	5320-00-754-0992	97403	13230E6685-AD6-7	RIVET, SOLID..... UOC:LTG, FPA, ABC	14
3	PAHZZA	5320-00-493-4101	81349	M24243/1-B604	RIVET, BLIND..... UOC:FPA	14
4	XDHZZA		80205	MS15795-848	WASHER, FLAT..... UOC:ABC, FPA	14
4	PAOZZA	5310-01-471-0640	30554	88-20033-11C	WASHER, FLAT..... UOC:LTG	14
5	MHHZZA		97403	13230E6288-2	FARING, RADIATOR..... UOC:ABC, FPA	1
5	MHHZZA		97403	13230E6288-3	FARING, RADIATOR..... UOC:FPA, LTG	2
6	PAHZZA	5325-01-500-5761	29381	1224201A	INSERT, FASTNER..... UOC:FPA	18
7	PAHZZA	5305-01-500-6912	29381	1434011A	SCREW, MACHINE..... UOC:FPA	18
8	PAHZZA	5310-01-012-3595	30554	69-561-6	NUT, PLAIN, ASSEMBLED..... UOC:FPA	4
9	PAHZZA	4730-00-278-4822	29510	120145	ELBOW, PIPE..... UOC:FPA	1

End of Figure

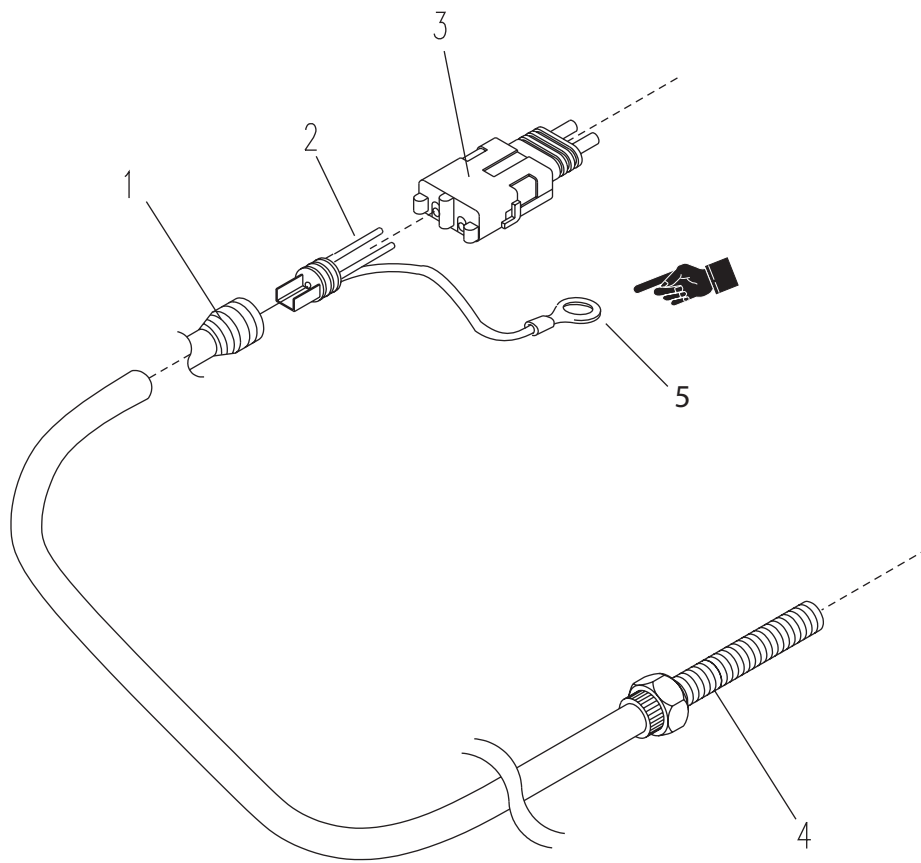

Figure C-19. Speed Sensor Assembly

Section II.

ARMY TM 9-6115-670-14&P

(1) Item No	(2) SMR CODE	(3) NSN	(4) CAGEC	(5) Part Number	(6) Description and Usable on Code (UOC)	(7) QTY
					GROUP 0108 SPEED SENSOR ASSEMBLE	
					FIG C-19	
1	PAOZZA	5975-01-310-5011	77060	12015323	BOOT,DUST AND MOIST..... UOC:FPB,FPA,ABC,LTG	2
2	XBOZZA		97403	13230E6240-1	SOCKET,TERMINAL..... UOC:LTG,FPB,FPA	2
2	PAOZZA	5999-01-323-4929	77060	1208 9188	CONTACT,ELECTRICAL..... UOC:ABC	2
3	PAOZZA	5935-01-214-5259	77060	12015792	CONNECTOR BODY,PLUG..... UOC:LTG,FPB,FPA,ABC	1
4	XBOZZA		05624	DYNT17200	PICKUP,MAGNETIC..... UOC:FPB,FPA,ABC,LTG	1
5	PAOZZA	5940-00-143-4771	96906	MS25036-103	TERMINAL,LUG..... UOC:ABC	1

End of Figure

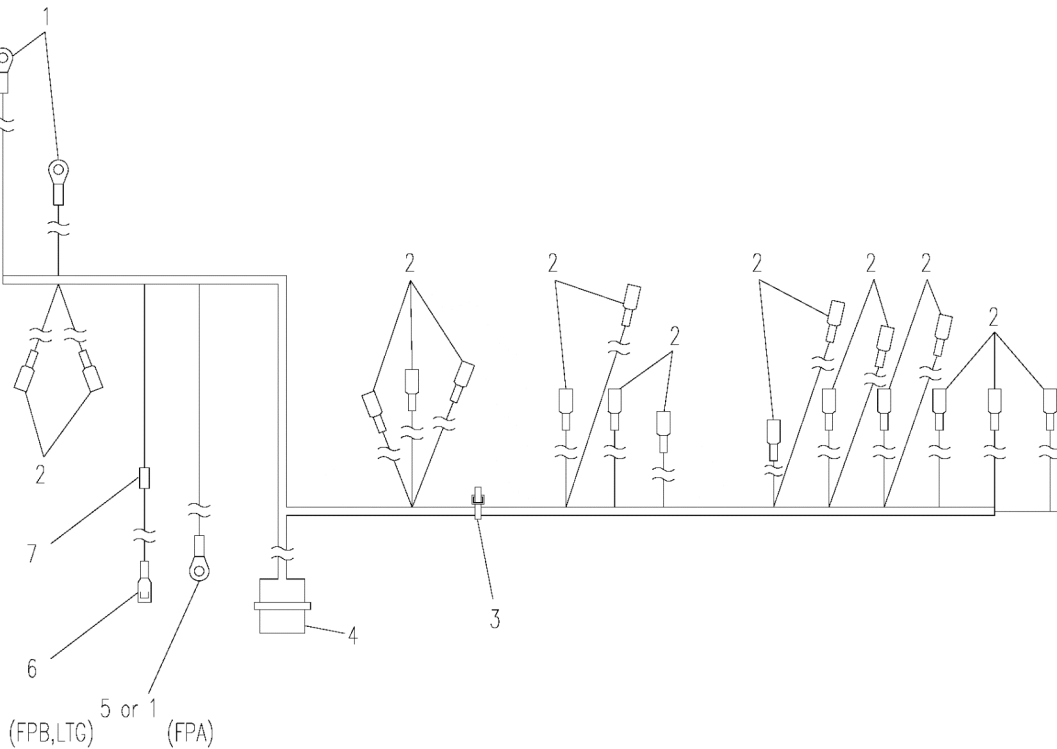

NOTE

Item 5 for SICPS/WIN-T only.

INSTRUCTIONS				
ITEM #	WIRE SIZE	CUT LENGTH	TAG	TERMINATION
1	18 GA	24"	A/CT2B	13217E3854-2
2	18 GA	5"	B/F1BA	13230E6231-1
3	18 GA	5.1/4"	C/F2C	13230E6231-1
4	18 GA	5.3/4"	D/F3D	13230E6231-1
5	18 GA	29.1/4"	E/VR1	13230E6231-1
6	18 GA	29.1/4"	F/VR2	13230E6231-1
7	18 GA	6.1/2"	J/J	13230E6231-1
8	18 GA	7.1/2"	K/K	13230E6231-1
9	18 GA	7.3/8"	L/L	13230E6231-1
10	18 GA	8"	M/M	13230E6231-1
11	18 GA	9.1/4"	N/R	13230E6231-1
12	18 GA	28.3/4"	P/S3	13217E3854-2
13	18 GA	30"	Q/S4	13217E3854-2
14	18 GA	8.1/4"	R/N	13230E6231-1
15	18 GA	9.1/4"	S/S	13230E6231-1
16	18 GA	9.5/8"	T/T	13230E6231-1
17	18 GA	28.1/2"	U/R387	13230E6236-2
18	18 GA	11"	V/V	13230E6231-1
19	18 GA	11"	W/W	13230E6231-1
20	18 GA	13"	X/X	13230E6231-1
21	18 GA	14"	Y/Y	13230E6231-1
22	18 GA	15.1/8"	Z/Z	13230E6231-1

JTACS
(FPA)

Figure C-20. Wiring Harness, J3, DC Box, APU (Sheet 1 of 2)

WIRE REF NO.	TERMINATION		TERMINATION		WIRE SIZE
	FROM	FIND NO.	TO	FIND NO.	
1	J3-A	13230E6652-1	CT2B	13226E0107-12	16 GA
2	J3-B	13230E6652-1	F1BA	13230E6231-3	16 GA
3	J3-C	13230E6652-1	F2C	13230E6231-3	16 GA
4	J3-D	13230E6652-1	F3D	13230E6231-3	16 GA
5	J3-E	13230E6652-1	VR1	13230E6231-3	16 GA
6	J3-F	13230E6652-1	VR2	13230E6231-3	16 GA
7	J3-J	13230E6652-1	J	13230E6231-3	16 GA
8	J3-K	13230E6652-1	K	13230E6231-3	16 GA
9	J3-L	13230E6652-1	L	13230E6231-3	16 GA
10	J3-M	13230E6652-1	M	13230E6231-3	16 GA
11	J3-N	13230E6652-1	R	13230E6231-3	16 GA
12	J3-P	13230E6652-1	S3	13226E0107-13	16 GA
13	J3-Q	13230E6652-1	S4	13226E0107-13	16 GA
14	J3-R	13230E6652-1	N	13230E6231-3	16 GA
15	J3-S	13230E6652-1	S	13230E6231-3	16 GA
16	J3-T	13230E6652-1	T	13230E6231-3	16 GA
17	J3-U	13230E6652-1	R387	13230E6236-2	16 GA
18	J3-V	13230E6652-1	V	13230E6231-3	16 GA
19	J3-W	13230E6652-1	W	13230E6231-3	16 GA
20	J3-X	13230E6652-1	X	13230E6231-3	16 GA
21	J3-Y	13230E6652-1	Y	13230E6231-3	16 GA
22	J3-Z	13230E6652-1	Z	13230E6231-3	16 GA

SICPS/WIN-T (FPB,LTG)

Figure C-20. Wiring Harness, J3, DC Box, APU (Sheet 2 of 2)

Section II.

ARMY TM 9-6115-670-14&P

(1) Item No	(2) SMR CODE	(3) NSN	(4) CAGEC	(5) Part Number	(6) Description and Usable on Code (UOC)	(7) QTY
					GROUP 0109 WIRING HARNESS, J3,DC BOX APU	
					FIG C-20	
1	PAFZZA	5940-00-143-4780	96906	MS25036-108	TERMINAL,LUG..... UOC:FPB,ABC,LTG	2
1	PAFZZA	5940-00-143-4771	96906	MS25036-103	TERMINAL,LUG..... UOC:FPA	3
2	PAFZZA	5940-01-082-3321	00779	3-350820-2	TERMINAL,QUICK DISC..... UOC:FPB,ABC,LTG	18
2	PAFZZA	5940-01-052-7646	14726	S05300F	TERMINAL,QUICK DISC..... UOC:FPA	18
3	XBFZZA	5975-00-111-3208	81343	MS3367-5-9	STRAP,TIEDOWN,ELECT..... UOC:FPB,ABC,LTG	V
4	PAFZZA	5935-01-110-1942	96906	MS3452W24-28P	CONNECTOR,RECEPTACL..... UOC:FPB,ABC,LTG	1
4	PAFZZA	5935-01-500-6843	29381	2160002A	CONNECTOR,RECEPTACL..... UOC:FPA	1
5	PAFZZA	5940-00-143-4774	96906	MS25036-153	TERMINAL,LUG..... UOC:FPB,ABC,LTG	1
6	PAFZZA	5940-01-478-6050	97403	13230E6236-2	TERMINAL,QUICK DISC..... UOC:FPB,FPA,ABC,LTG	1
7	XBFZZA		29381	2219026A	MARKER,WIRE..... UOC:FPA	24

End of Figure

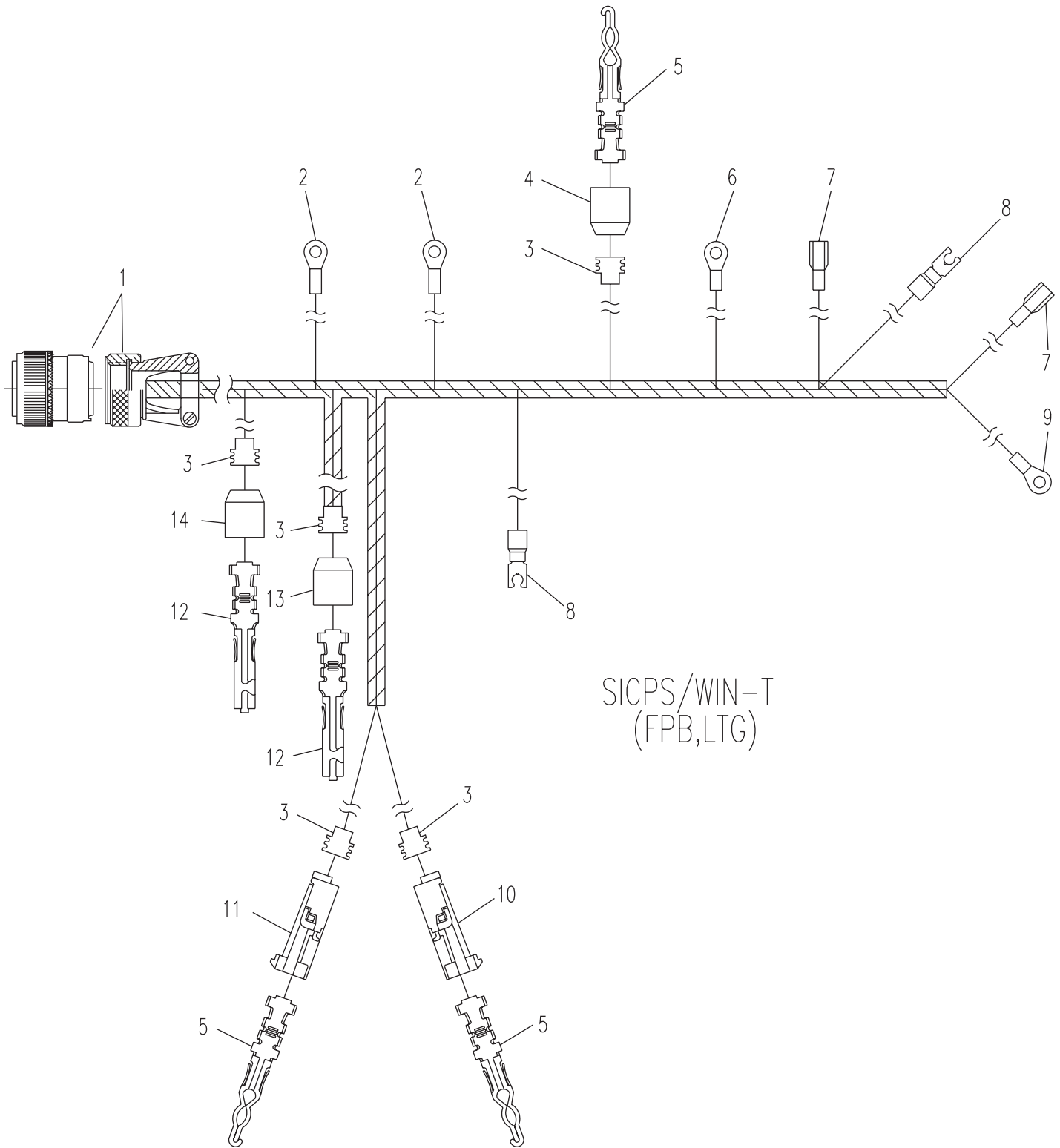

SICPS/WIN-T
(FPB,LTG)

Figure C-21. Wiring Harness, Engine, P1 (Sheet 1 of 3)

WIRE REF NO.	TERMINATION		TERMINATION		WIRE SIZE
	FROM	FIND NO.	TO	FIND NO.	
1	P1-A	13230E6650-1	P4-A	13230E6238-3, 13230E6240-3, 13230E6242-1	16 GA
2	P1-B	13230E6650-1	P4-B	13230E6238-3, 13230E6240-3, 13230E6242-1	16 GA
3	P1-C	13230E6650-1	P5	13230E6238-3, 13230E6240-3, 13230E6242-1	16 GA
4	P1-D	13230E6650-1	STR	13230E6231-3	16 GA
5	P1-E	13230E6650-1	AF	13230E6231-3	16 GA
6	P1-F	13230E6650-1	P4-C	13230E6238-3, 13230E6240-3, 13230E6242-1	16 GA
7	P1-J	13230E6650-1	S8	13226E0107-22	12 GA
8	P1-K	13230E6650-1	ALT	13226E0107-21	12 GA
9	P1-L	13230E6650-1	GP	13226E0107-18	12 GA
10	P1-M	13230E6650-1	MH	13226E0107-18	12 GA
11	P1-N	13230E6650-1	WTS	13230E6237-4	16 GA
12	P1-P	13230E6650-1	P8-A	13230E6239-2, 13230E6241-3, 13230E6242-1	16 GA
13	P1-R	13230E6650-1	P7-B	13230E6239-4, 13230E6241-3, 13230E6242-1	16 GA
14	P1-S	13230E6650-1	P7-D	13230E6239-4, 13230E6241-3, 13230E6242-1	16 GA
15	P1-T	13230E6650-1	P7-A	13230E6239-4, 13230E6241-3, 13230E6242-1	16 GA
16	P1-U	13230E6650-1	P8-B	13230E6239-2, 13230E6241-3, 13230E6242-1	16 GA
17	P1-V	13230E6650-1	OPS	13230E6237-4	16 GA
18	P1-W	13230E6650-1	TS	13230E6306, 13230E6241-3, 13230E6242-1	16 GA
19	P1-X	13230E6650-1	P7-C	13230E6239-4, 13230E6241-3, 13230E6242-1	16 GA

SICPS/WIN-T (FPB,LTG)

Figure C-21. Wiring Harness, Engine, P1 (Sheet 2 of 3)

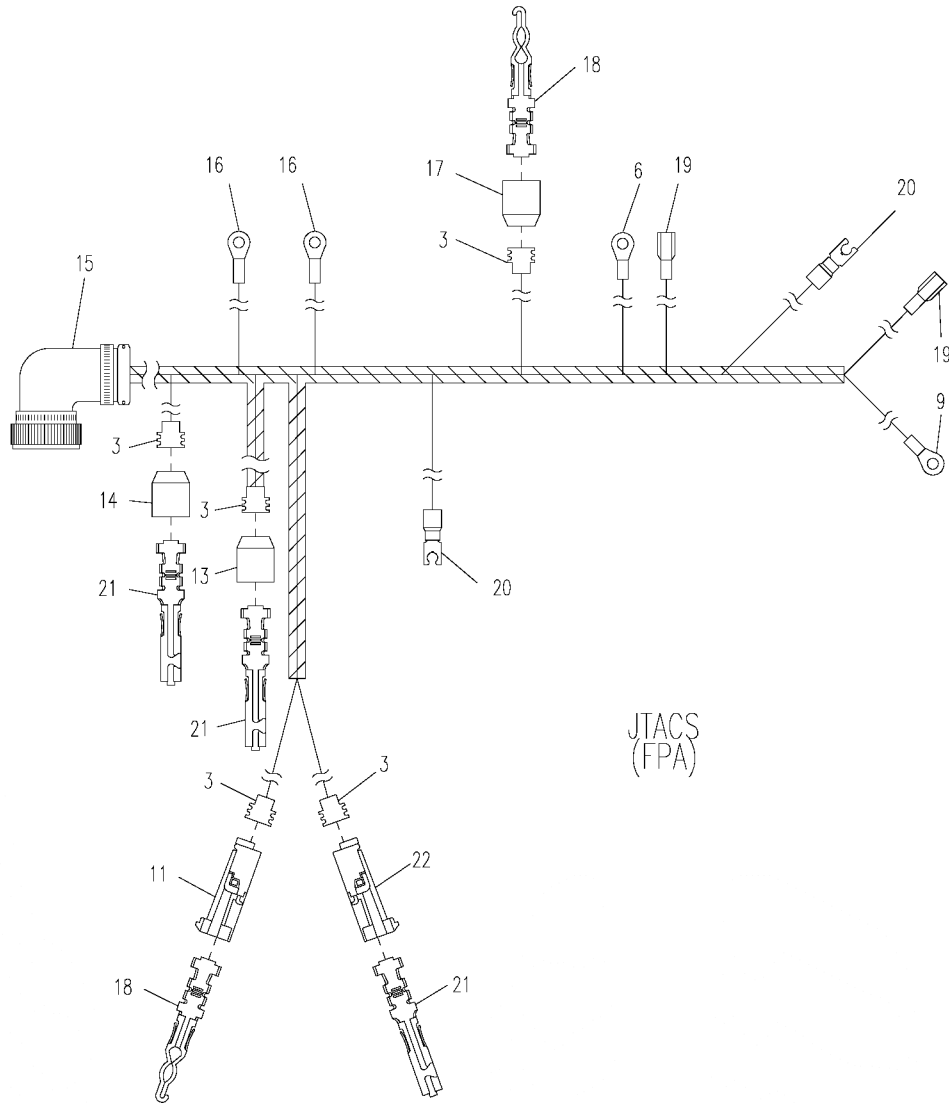

INSTRUCTIONS				
ITEM#	WIRE SIZE	APPROX. CUT LENGTH	MARKING	TERMINATION
A	18 GA	19"	A/3A	2126002
B	18 GA	19"	B/3B	2126002
C	18 GA	13.1/4"	C/GOV	13230E6238-1
D	18 GA	51"	D/STR	2113001
E	18 GA	49.1/2"	E/AF	2113001
J	12 GA	51.1/2"	J/SB	13226E0107-22
K	12 GA	43.1/2"	K/ALT	13226E0107-21
L	12 GA	16"	L/GP	2111001
M	12 GA	19.3/4"	M/MH	2111001
N	18 GA	35.3/4"	N/WTS	2112003
P	18 GA	27"	P/2A	2126002
R	18 GA	27"	R/4B	2126006
S	18 GA	27"	S/4D	2126006
V	18 GA	48"	V/OPS	2112003
W	18 GA	39"	W/TS	2126006
X	18 GA	27"	X/4C	2126006
F	18 GA	19"	F/3C	2126002
T	18 GA	27"	T/4A	2126006
U	18 GA	27"	U/2B	2126002

Figure C-21. Wiring Harness, Engine, P1 (Sheet 3 of 3)

Section II.

ARMY TM 9-6115-670-14&P

(1) Item No	(2) SMR CODE	(3) NSN	(4) CAGEC	(5) Part Number	(6) Description and Usable on Code (UOC)	(7) QTY
GROUP 0110 WIRING HARNESS, ENGINE, P1						
FIG C-21						
1	PAFZZA	5935-01-478-5219	96906	MS3408DJ28D-11S	CONNECTOR, PLUG, ELEC..... UOC: LTG, FPB	1
2	PAOZZA		97403	13226E0107-18	TERMINAL, LUG..... UOC: FPB, LTG	1
2	PAFZZA	5940-00-204-8990	96906	MS25036-111	TERMINAL, LUG..... UOC: LTG, FPB	2
3	PCOZZA	5975-01-310-5011	77060	12015323	BOOT, DUST AND MOIST..... UOC: ABC	4
3	PAFZZA	5975-01-310-5011	77060	12015323	BOOT, DUST AND MOIST..... UOC: LTG, FPB, FPA	11
4	PAFZZA	5935-01-478-6077	97403	13230E6306	CONNECTOR, PLUG, ELEC..... UOC: LTG, FPB	1
5	PAFZAA	5999-01-406-4110	77060	12124582	CONTACT, ELECTRICAL..... UOC: LTG, FPB	7
6	PAFZZA	5940-00-143-4777	81343	MS25036-157	TERMINAL, LUG..... UOC: FPB, FPA, ABC, LTG	1
7	PAFZZA	5940-01-082-3321	00779	3-350820-2	TERMINAL, QUICK DISC..... UOC: FPB, ABC, LTG	2
8	PAFZZA	5940-01-478-6081	98410	191150079	TERMINAL, LUG..... UOC: FPB, ABC, LTG	2
9	PAFZZA	5940-00-113-8183	96906	MS25036-113	TERMINAL, LUG..... UOC: FPB, FPA, ABC, LTG	1
10	PAFZZA	5935-01-214-4163	22785	12010973	CONNECTOR BODY, PLUG..... UOC: LTG, FPB	1
11	PAFZZA	5935-01-336-5396	77060	1201 0974	CONNECTOR BODY, PLUG..... UOC: LTG, FPB, FPA, ABC	1
12	PAFZZA	5999-01-422-9740	19207	12420936	CONTACT, ELECTRICAL..... UOC: LTG, FPB	4
13	PAFZZA	5935-01-292-2336	77060	12015793	CONNECTOR, PLUG, ELEC..... UOC: LTG, FPB, FPA	1
14	PAFZZA	5935-01-291-2814	10988	L124720	CONNECTOR, PLUG, ELEC..... UOC: LTG, FPB, FPA	1
15	PAFZAA	5935-00-805-3284	96906	MS3108R28-11S	CONNECTOR, PLUG, ELEC..... UOC: FPA	1
16	PAFZZA	5940-01-503-8272	29381	2111001A	TERMINAL, LUG..... UOC: FPA	2
17	PAFZZA	5999-01-500-4877	29381	2160005A	CONNECTOR PLUG, ELEC..... UOC: FPA	1
18	PAFZZA	5999-01-500-9311	29381	2126006A	CONTACT, ELECTRICAL..... UOC: FPA	5
19	PAFZZA	5940-01-052-7646	14726	S05300F	TERMINAL, QUICK DISC..... UOC: FPA	2
1A	PAFZZA		97403	13230E6972-1	CONNECTOR, PLUG..... UOC: ABC	1
1B	PAOZZA		97403	13230E6974-2	CLAMP, CABLE..... UOC: ABC	1
20	PAFZZA	5940-01-500-6511	29381	2112003A	TERMINAL, LUG..... UOC: FPA	2
21	PAFZZA	5999-01-500-9308	29381	2126002A	CONTACT, ELECTRICAL..... UOC: FPA	6
22	PAFZZA	5935-01-214-5259	77060	12015792	CONNECTOR BODY, PLUG..... UOC: FPA	2
23	PAOZZA	5999-01-406-4110	77060	12124582	CONTACT, ELECTRICAL..... UOC: ABC	5
24	MOOZZA		97403	13230E6973-19-12 0 INCH	BRAID, WIRE..... UOC: ABC	1

Section II.

ARMY TM 9-6115-670-14&P

(1) Item No	(2) SMR CODE	(3) NSN	(4) CAGEC	(5) Part Number	(6) Description and Usable on Code (UOC)	(7) QTY
GROUP 0110 WIRING HARNESS, ENGINE, P1						
FIG C-21						
25	MOOZA		97403	13230E6973-31-6I NCH	BRAID,WIRE..... UOC:ABC	1
26	MOOZA		97403	13230E6653-5-217 INCH	WIRE,ELECTRICAL..... UOC:ABC	1
27	MOOZA		97403	13230E6653-7-66I NCH	WIRE,ELECTRICAL..... UOC:ABC	1
28	PAOZA	5975-00-111-3208	81343	MS3367-5-9	STRAP,TIEDOWN,ELECT..... UOC:ABC	37
29	PAOZA	5940-00-143-4780	96906	MS25036-108	TERMINAL,LUG..... UOC:ABC	1
30	PAOZA	5940-00-143-4775	75037	MNG10-8RX	TERMINAL,LUG..... UOC:ABC	1

End of Figure

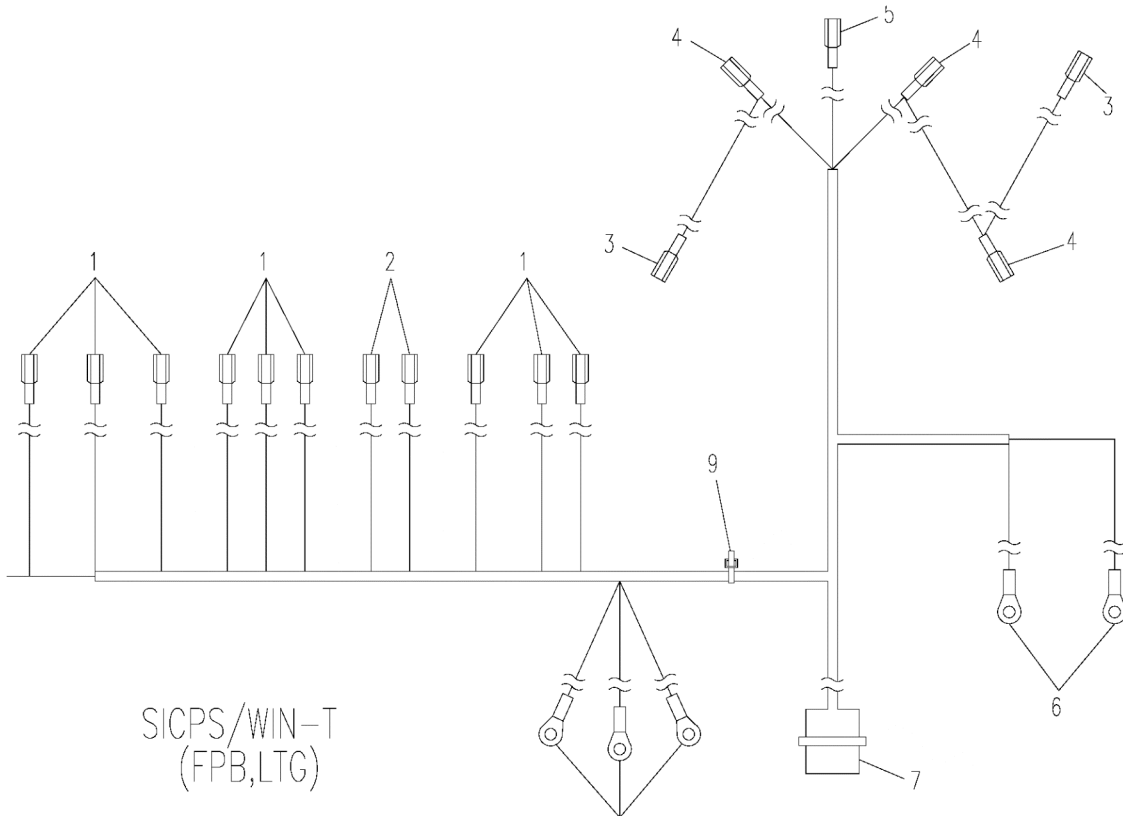

WIRE REF NO.	TERMINATION		TERMINATION		WIRE SIZE
	FROM	FIND NO.	TO	FIND NO.	
1	J1-A	13230E6652-2	R187	13230E6236-3	16 GA
2	R287	13230E6236-1	R187	13230E6236-3	18 GA
3	J1-B	13230E6652-2	R130	13230E6236-3	16 GA
4	R186	13230E6236-3	R130	13230E6236-3	18 GA
5	R186	13230E6236-3	R230	13230E6236-1	18 GA
6	J1-C	13230E6652-2	IGN	13230E6231-3	16 GA
7	J1-D	13230E6652-2	STA	13230E6231-3	16 GA
8	J1-E	13230E6652-2	IGN	13230E6231-3	16 GA
9	J1-F	13230E6652-2	R185	13230E6236-2	16 GA
10	J1-J	13230E6652-2	S1	13226E0107-23	12 GA
11	J1-K	13230E6652-2	S2	13226E0107-23	12 GA
12	J1-L	13230E6652-2	GP	13230E6231-5	12 GA
13	J1-M	13230E6652-2	MH	13230E6231-5	12 GA
14	J1-N	13230E6652-2	WT	13230E6231-3	16 GA
15	J1-P	13230E6652-2	FP	13230E6231-3	16 GA
16	J1-R	13230E6652-2	FPR	13230E6231-3	16 GA
17	J1-S	13230E6652-2	GND	13226E0107-13	16 GA
18	J1-T	13230E6652-2	GND	13226E0107-13	16 GA
19	J1-U	13230E6652-2	GND	13226E0107-13	16 GA
20	J1-V	13230E6652-2	X	13230E6231-3	16 GA
21	J1-W	13230E6652-2	Y	13230E6231-3	16 GA
22	J1-X	13230E6652-2	Z	13230E6231-3	16 GA

Figure C-22. Wiring Harness, J1 (Sheet 1 of 2)

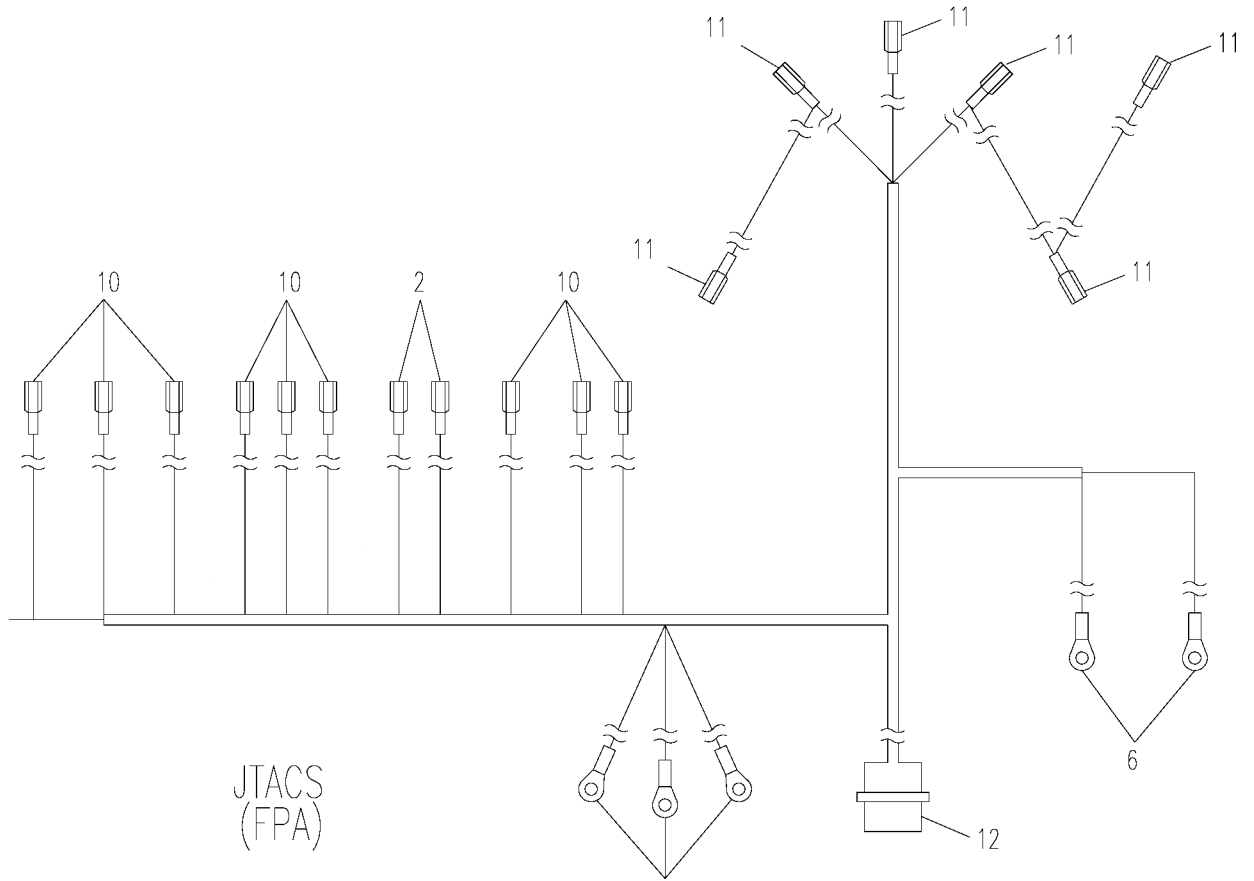

INSTRUCTIONS				
ITEM #	WIRE SIZE	APPROX. CUT LENGTH	MARKING	TERMINATION
1	18 GA	7.1/2"	R187/A	2123008
2	18 GA	7.1/2"	R130/B	2123008
3	18 GA	22.3/4"	IGN/C	2113001
4	18 GA	26.3/8"	STA/D	2113001
5	18 GA	23"	IGNE/E	2113001
6	12 GA	6.1/4"	S1/J	13226E0107-23
7	12 GA	10"	S2/K	13226E0107-23
8	12 GA	26.3/4"	GPL/L	13230E6231-5
9	12 GA	28"	MH/M	13230E6231-5
10	18 GA	28.3/4"	WT/N	2113001
11	18 GA	28.3/4"	FPP	2113001
12	18 GA	30"	FPR/R	2113001
13	18 GA	17.3/4"	GND/S	2111003
14	18 GA	32"	X/V	2113001
15	18 GA	32.3/4"	Y/W	2113001
16	18 GA	33"	Z/X	2113001
17	18 GA	7.1/2"	R185/F	2123008
18	18 GA	3"	-	2123008
19	18 GA	3"	-	2123008
20	18 GA	3"	-	2123008
21	18 GA	17.3/4"	GND/T	2111003
22	18 GA	17.3/4"	GND/U	2111003

Figure C-22. Wiring Harness, J1 (Sheet 2 of 2)

Section II.

ARMY TM 9-6115-670-14&P

(1) Item No	(2) SMR CODE	(3) NSN	(4) CAGEC	(5) Part Number	(6) Description and Usable on Code (UOC)	(7) QTY
GROUP 0111 WIRING HARNESS,J1						
FIG C-22						
1	PAFZZA	5940-01-082-3321	00779	3-350820-2	TERMINAL,QUICK DISC..... UOC:LTG,FPB	9
1	PAOZZA	5940-01-082-3321	00779	3-350820-2	TERMINAL,QUICK DISC..... UOC:ABC	7
2	PAFZZA	5940-01-264-6657	81495	442 6474	TERMINAL,QUICK DISC..... UOC:LTG,FPB,FPA	2
2	PAOZZA	5940-01-264-6657	81495	442 6474	TERMINAL,QUICK DISC..... UOC:ABC	2
3	PAFZZA	5940-01-027-4669	56501	A-250	TERMINAL,QUICK DISC..... UOC:LTG,FPB	2
3	PAOZZA	5940-00-620-9780	00779	42282-2	TERMINAL,QUICK DISC..... UOC:ABC	6
4	PAFZZA	5940-01-478-6072	97403	13230E6236-3	TERMINAL,QUICK DISC..... UOC:LTG,FPB	3
5	PAFZZA	5940-01-478-6050	97403	13230E6236-2	TERMINAL,QUICK DISC..... UOC:LTG,FPB	1
6	PAFZZA	5940-00-113-9826	96906	MS25036-114	TERMINAL,LUG..... UOC:FPB,FPA,ABC,LTG	2
7	PAFZAA	5935-01-226-8367	96906	MS3452W28-11P	CONNECTOR,RECEPTACL..... UOC:LTG,FPB	1
8	PAFZZA	5940-00-143-4780	96906	MS25036-108	TERMINAL,LUG..... UOC:LTG,FPB	3
8	PAOZZA	5940-00-143-4780	96906	MS25036-108	TERMINAL,LUG..... UOC:ABC	2
9	XBFZZA	5975-00-111-3208	81343	MS3367-5-9	STRAP,TIEDOWN,ELECT..... UOC:FPB,ABC,LTG	V
10	PAFZZA	5940-01-052-7646	14726	S05300F	TERMINAL,QUICK DISC..... UOC:FPA	9
11	PAFZZA	5940-01-478-6050	97403	13230E6236-2	TERMINAL,QUICK DISC..... UOC:FPA	6
12	PAOZZA		97403	13230E6652-2	CONNECTOR,RECEPTACL..... UOC:ABC	1
12	PAOZZA	5935-01-292-2336	77060	12015793	CONNECTOR,PLUG,ELEC..... UOC:ABC	1
12	PAFZZA	5935-01-500-3229	29381	2160003A	CONNECTOR,RECEPTACL..... UOC:FPA	1
13	PAFZZA	5940-00-143-4771	96906	MS25036-103	TERMINAL,LUG..... UOC:FPA	4
14	MOOOZA		97403	13230E6653-5-276 INCH	WIRE,ELECTRICAL..... UOC:ABC	1
15	MOOOZA		97403	13230E6653-7-96I NCH	WIRE,ELECTRICAL..... UOC:ABC	1
16	PAOZZA	5999-01-422-9740	19207	12420936	CONTACT,ELECTRICAL..... UOC:ABC	3
17	PCOZZA	5975-01-310-5011	77060	12015323	BOOT,DUST AND MOIST..... UOC:ABC	3
18	MOOZZA		97403	13230E6653-5-84I NCH	WIRE,ELECTRICAL..... UOC:ABC	1
19	MOOOZA		97403	13230E6653-4-18I NCH	WIRE,ELECTRICAL..... UOC:ABC	1

End of Figure

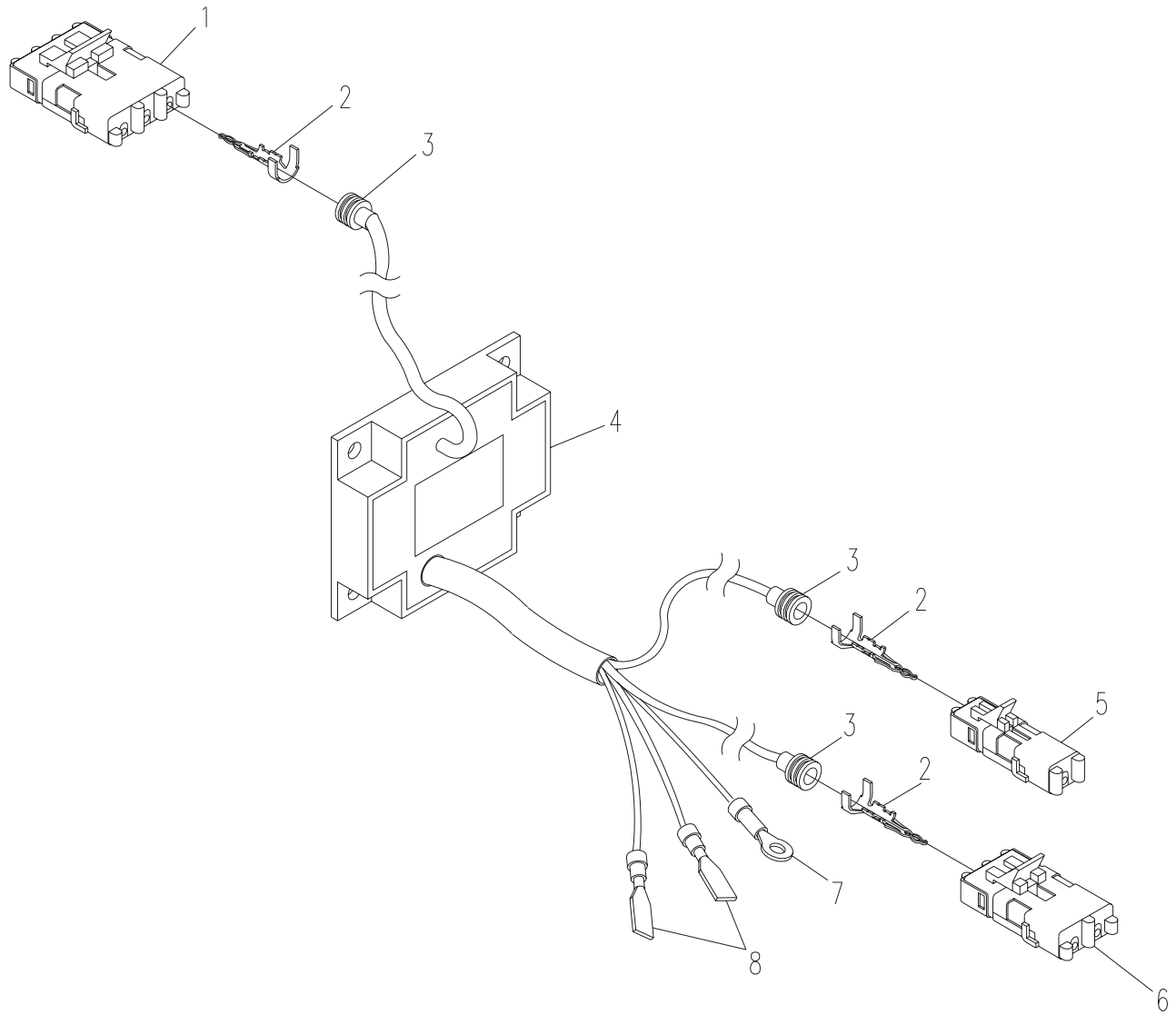

Figure C-23. Governor Control Assembly

Section II.

ARMY TM 9-6115-670-14&P

(1) Item No	(2) SMR CODE	(3) NSN	(4) CAGEC	(5) Part Number	(6) Description and Usable on Code (UOC)	(7) QTY
GROUP 0112 GOVERNOR CONTROL ASSEMBLY						
FIG C-23						
1	PAOZZA	5935-01-336-6409	77060	1201 0717	CONNECTOR BODY, PLUG..... UOC:FPB,FPA,ABC,LTG	1
2	XBOZZA		97403	13230E6241-3	CONTACT, ELECTRICAL..... UOC:FPB,FPA,ABC,LTG	6
3	PAOZZA	5975-01-310-5011	77060	12015323	BOOT, DUST AND MOIST..... UOC:FPB,FPA,ABC,LTG	6
4	XBOZZA		97403	13230E6250	GOVERNOR CONTROL..... UOC:FPB,FPA,ABC,LTG	1
5	PAOZZA	5935-01-338-3532	64678	1201 0996	CONNECTOR BODY, PLUG..... UOC:FPB,FPA,ABC,LTG	1
6	PAOZZA	5935-01-214-4163	22785	12010973	CONNECTOR BODY, PLUG..... UOC:FPB,FPA,ABC,LTG	1
7	PAOZZA	5940-00-143-4771	81343	MS25036-103	TERMINAL, LUG..... UOC:FPB,FPA,ABC,LTG	1
8	XDOZZA	5940-01-052-7646	14726	S05300F	TERMINAL, QUICK DISC..... UOC:FPB,FPA,ABC,LTG	2
9	PAOZZA	5310-01-164-4693	96906	MS27130-S27	NUT, PLAIN, BLIND RIV..... UOC:ABC	2
10	MOOZZA		97403	13230E6973-36-15 INCH	BRAID, WIRE..... UOC:ABC	1
11	PAOZZA		94833	111K1139	STRAP, TIEDOWN, ELECT..... UOC:ABC	2

End of Figure

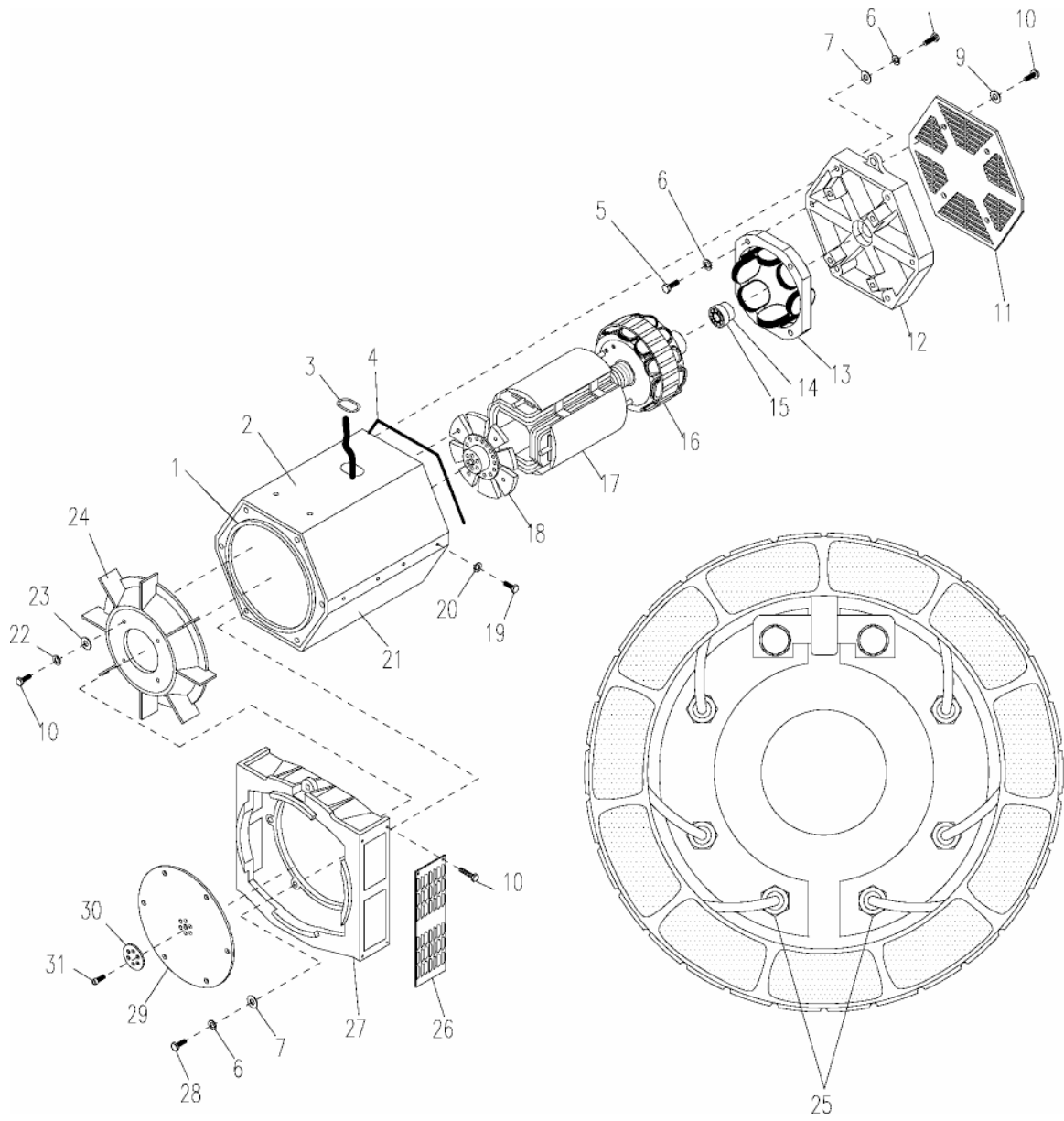

Figure C-24. Generator, 10 kW, 60 Hz

Section II.

ARMY TM 9-6115-670-14&P

(1) Item No	(2) SMR CODE	(3) NSN	(4) CAGEC	(5) Part Number	(6) Description and Usable on Code (UOC)	(7) QTY
GROUP 0113 GENERATOR, 10KW, 60HZ						
FIG C-24						
1	XBHZZA		4X687	122-N6000	STATOR ASSY..... UOC:FPB,FPA,ABC,LTG	1
2	XBHZZA		4X687	130-20799	COVER,STATOR, TOP..... UOC:FPB,FPA,ABC,LTG	1
3	XBHZZA		4X687	003-25158	GROMMET,CABLE..... UOC:FPB,FPA,ABC,LTG	1
4	MHHZZA		4X687	030-02813-1METER	CHANNEL,SEALING MAKE FROM CHANNEL,SEALING P/N (4X687) 030-02813; 39 CHES..... UOC:FPB,FPA,ABC,LTG	1
5	XBHZZA		4X687	015-41607	SCREW,HEX HD..... UOC:FPB,FPA,ABC,LTG	4
6	XBHZZA		4X687	028-31507	WASHER,LOCK..... UOC:FPB,FPA,ABC,LTG	16
7	XBHZZA		4X687	130-20123	WASHER,CLAMPING..... UOC:FPB,FPA,ABC,LTG	12
8	XBHZZA		4X687	016-40716	SCREW,HEX HD..... UOC:FPB,FPA,ABC,LTG	6
9	XBFZZA		4X687	029-63002	WASHER,FLAT..... UOC:FPB,FPA,ABC,LTG	6
10	XBFZZA		4X687	005-04076	SCREW,HEX HD..... UOC:FPB,FPA,ABC,LTG	18
11	XBFZZA		4X687	130-20661	COVER,LOUVERED..... UOC:FPB,FPA,ABC,LTG	1
12	XBHZZA		4X687	130-20667	BRACKET,END..... UOC:FPB,FPA,ABC,LTG	1
13	XBHZZA		4X687	130-1379	EXCITER,STATOR ASSY..... UOC:FPB,FPA,ABC,LTG	1
14	PAHZZA	5331-01-479-0530	4X687	051-21792	PACKING,PREFORMED..... UOC:FPB,FPA,ABC,LTG	1
15	PAHZZA	3110-01-486-4864	4X687	051-01058	BEARING UNIT,BALL..... UOC:FPB,FPA,ABC,LTG	1
16	XBHZZA		4X687	130-1384	EXCITER,ROTOR ASSY..... UOC:FPB,FPA,ABC,LTG	1
17	XBHZZA		4X687	122-NR01S571221	ROTOR ASSY..... UOC:FPB,FPA,ABC,LTG	1
18	XBHZZA		4X687	130-20930	HUB,FAN..... UOC:FPB,FPA,ABC,LTG	1
19	XBHZZA		4X687	016-40817	SCREW,HEX HD..... UOC:FPB,FPA,ABC,LTG	8
20	XBHZZA		4X687	028-31508	WASHER,LOCK..... UOC:FPB,FPA,ABC,LTG	8
21	XBHZZA		4X687	130-20800	COVER,STATOR,BOTTOM..... UOC:FPB,FPA,ABC,LTG	1
22	XBHZZA		4X687	028-31506	WASHER,LOCK..... UOC:FPB,FPA,ABC,LTG	4
23	XBHZZA		4X687	029-63006	WASHER,FLAT..... UOC:FPB,FPA,ABC,LTG	4
24	XBHZZA		4X687	130-21297	FAN,COOLING..... UOC:FPB,FPA,ABC,LTG	1
25	XCHHHA		97403	ASSEMBLY-1	MAIN RECTIFIER ASSY SEE FIGURE C-25 FOR BREAKDOWN..... UOC:FPB,FPA,ABC,LTG	1
26	XBFZZA		4X687	130-21325	COVER,SCREEN..... UOC:FPB,FPA,ABC,LTG	2
27	XBHZZA		4X687	130-21020	ADAPTOR,DRIVE END..... UOC:FPB,FPA,ABC,LTG	1

Section II.

ARMY TM 9-6115-670-14&P

(1) Item No	(2) SMR CODE	(3) NSN	(4) CAGEC	(5) Part Number	(6) Description and Usable on Code (UOC)	(7) QTY
GROUP 0113 GENERATOR, 10KW, 60HZ						
FIG C-24						
25	XCHHHA		97403	ASSEMBLY-1	MAIN RECTIFIER ASSY SEE FIGURE C-25 FOR BREAKDOWN.....	1
					UOC:FPB,FPA,ABC,LTG	
26	XBFZZA		4X687	130-21325	COVER, SCREEN.....	2
					UOC:FPB,FPA,ABC,LTG	
27	XBHZZA		4X687	130-21020	ADAPTOR, DRIVE END.....	1
					UOC:FPB,FPA,ABC,LTG	
28	XBHZZA		4X687	016-40717	SCREW, HEX HD.....	6
					UOC:FPB,FPA,ABC,LTG	
29	XBHZZA		4X687	130-20761	COUPLING, DISK.....	1
					UOC:FPB,FPA,ABC,LTG	
30	XBHZZA		4X687	130-21017	COUPLING, PRES PLATE.....	1
					UOC:FPB,FPA,ABC,LTG	
31	XBHZZA		4X687	024-70618	SCREW, HEX HD.....	6
					UOC:FPB,FPA,ABC,LTG	

End of Figure

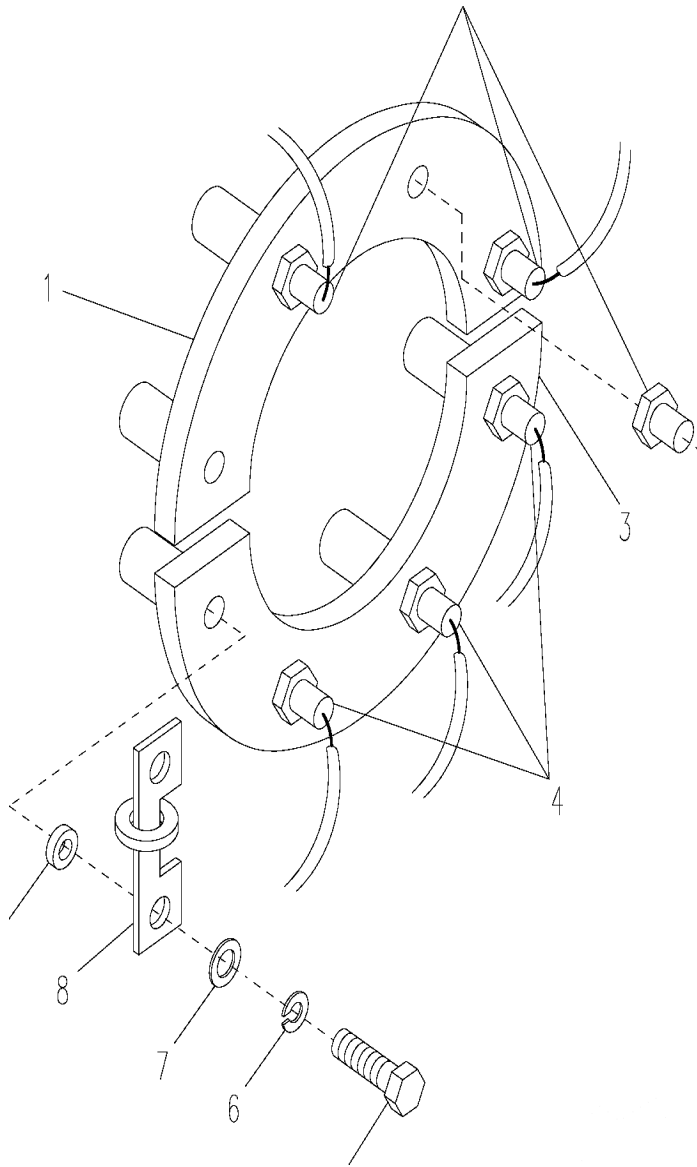

Figure C-25. Main Rectifier Assembly

Section II.

ARMY TM 9-6115-670-14&P

(1) Item No	(2) SMR CODE	(3) NSN	(4) CAGEC	(5) Part Number	(6) Description and Usable on Code (UOC) Group 011301 MAIN RECTIFIER ASSEMBLY FIG C-25	(7) QTY
1	XBHZZA		4X687	130-1413	RECTIFIER, FOWARD..... UOC: FPB, FPA, ABC, LTG	1
2	PAHZZA	5961-01-486-1969	4X687	073-50032	SEMICONDUCTOR DEVIC..... UOC: FPB, FPA, ABC, LTG	3
3	XBHZZA		4X687	130-1414	RECTIFIER, REVERSE..... UOC: FPB, FPA, ABC, LTG	1
4	PAHZZA	5961-01-486-1973	4X687	073-50033	SEMICONDUCTOR DEVIC..... UOC: FPB, FPA, ABC, LTG	3
5	XBHZZA		4X687	001-08104	SCREW, HEX HD..... UOC: FPB, FPA, ABC, LTG	2
6	XBHZZA		4X687	028-31506	WASHER, LOCK..... UOC: FPB, FPA, ABC, LTG	4
7	XBHZZA		4X687	029-63002	WASHER, FLAT..... UOC: FPB, FPA, ABC, LTG	2
8	XBHZZA		4X687	073-08063	VARISTOR..... UOC: FPB, FPA, ABC, LTG	1
9	XBHZZA		4X687	130-20602	WASHER, RECTIFIER..... UOC: FPA, ABC, FPB	4

End of Figure

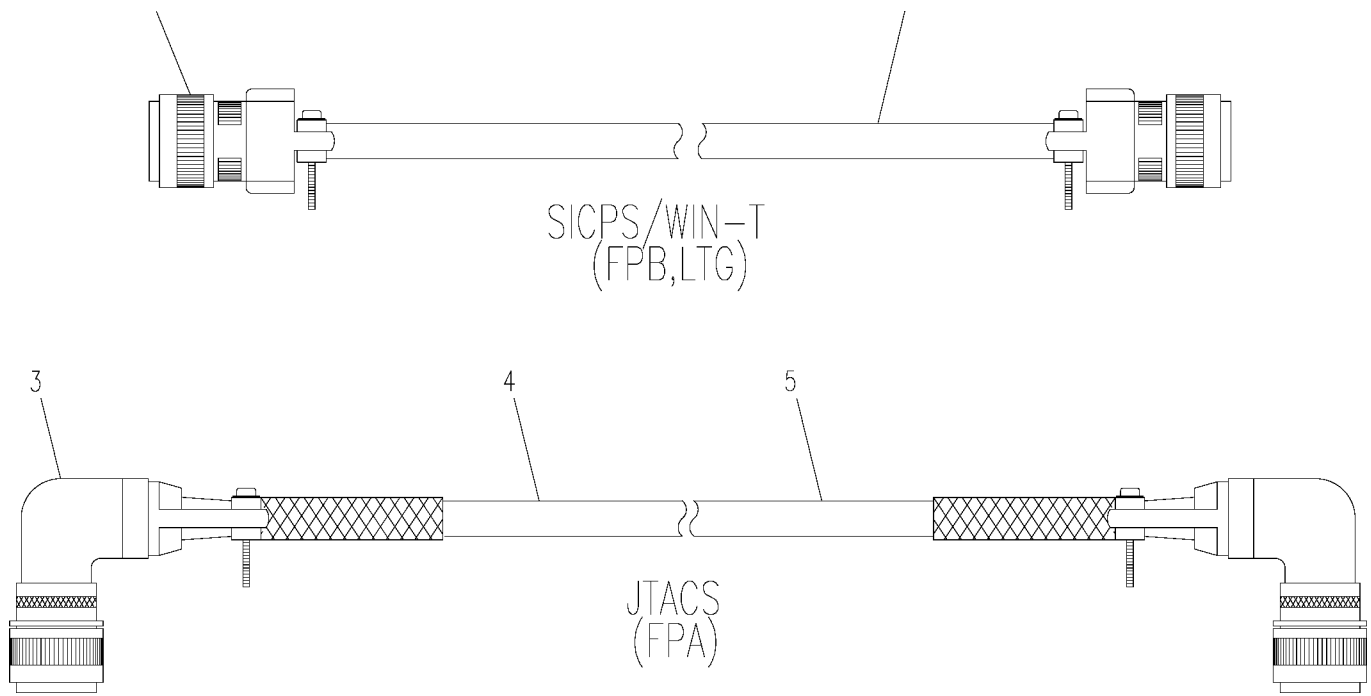

Figure C-26. Control Cable

Section II.

ARMY TM 9-6115-340-14&P

(1) Item No	(2) SMR CODE	(3) NSN	(4) CAGEC	(5) Part Number	(6) Description and Usable on Code (UOC)	(7) QTY
					GROUP 02 WIRING HARNESS, CONTROL CABLE FIG C-26	
1	PAFZZA	5935-01-095-4657	96906	MS3406DJ24A28S	CONNECTOR, PLUG, ELEC..... UOC: ABC, FPB	2
1	PAFZAA	5935-01-500-6132	97403	13230E6650-2	CONNECTOR, PLUG, ELEC..... UOC: LTG	2
2	MFFZZA		97403	13230E6888-60	CABLE, MULTICON W/SH..... UOC: ABC, FPB	1
2	MFFZZA		97403	13230E6888-132	CABLE, MULTICON W/SH..... UOC: LTG	1
3	PAFZZA	5935-01-500-6847	29381	2160001A	CONNECTOR, RECEPTACL..... UOC: FPA	2
4	MFFZZA		97403	13230E6888-120	CABLE, MULTICON W/SH..... UOC: FPA	1
5	XBFZZA		29381	2219002A-8	TUBING, HEAT SHRINK..... UOC: FPA	2

End of Figure

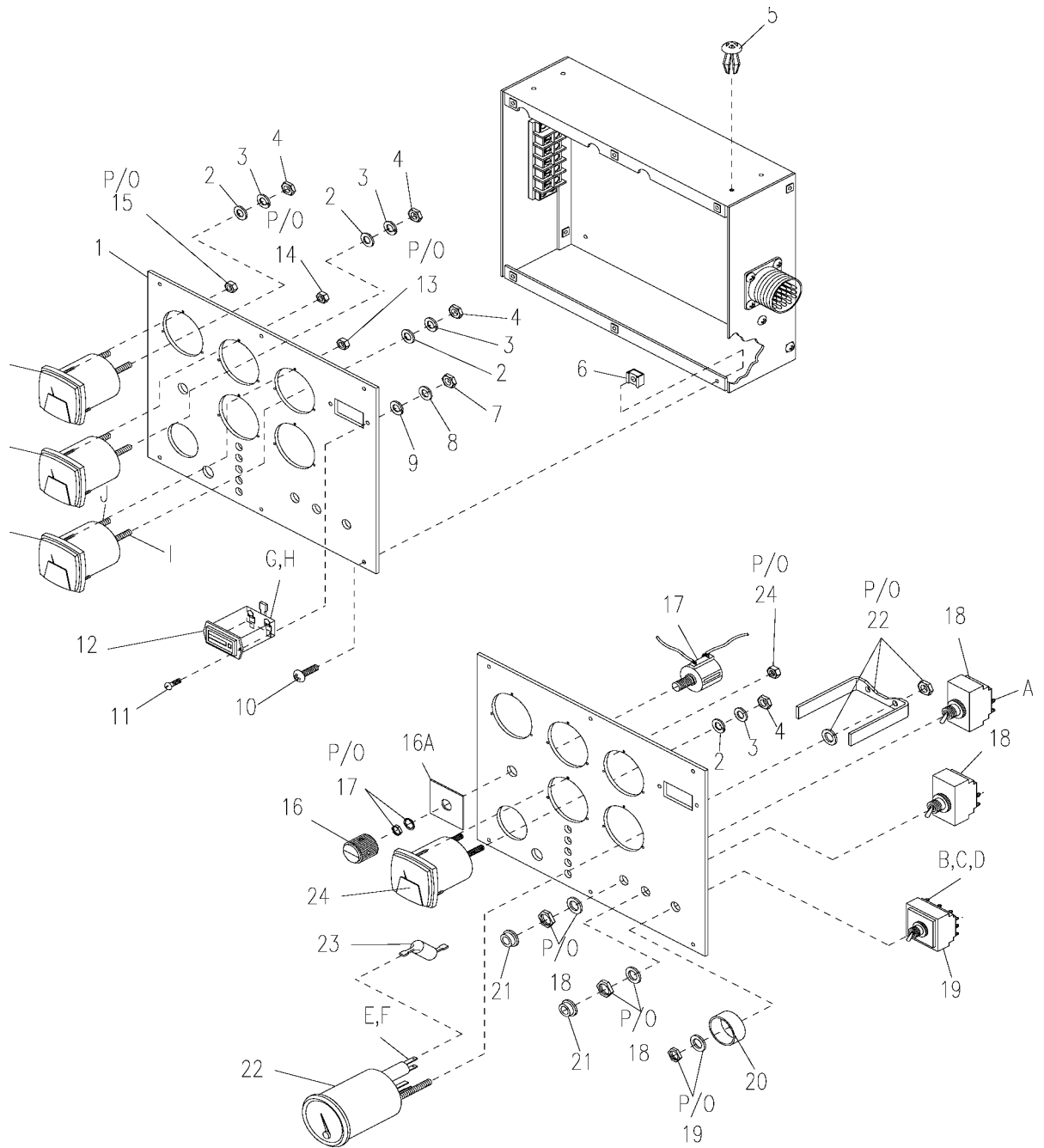

Figure C-27. APU Control Box Assembly (Sheet 1 of 3)

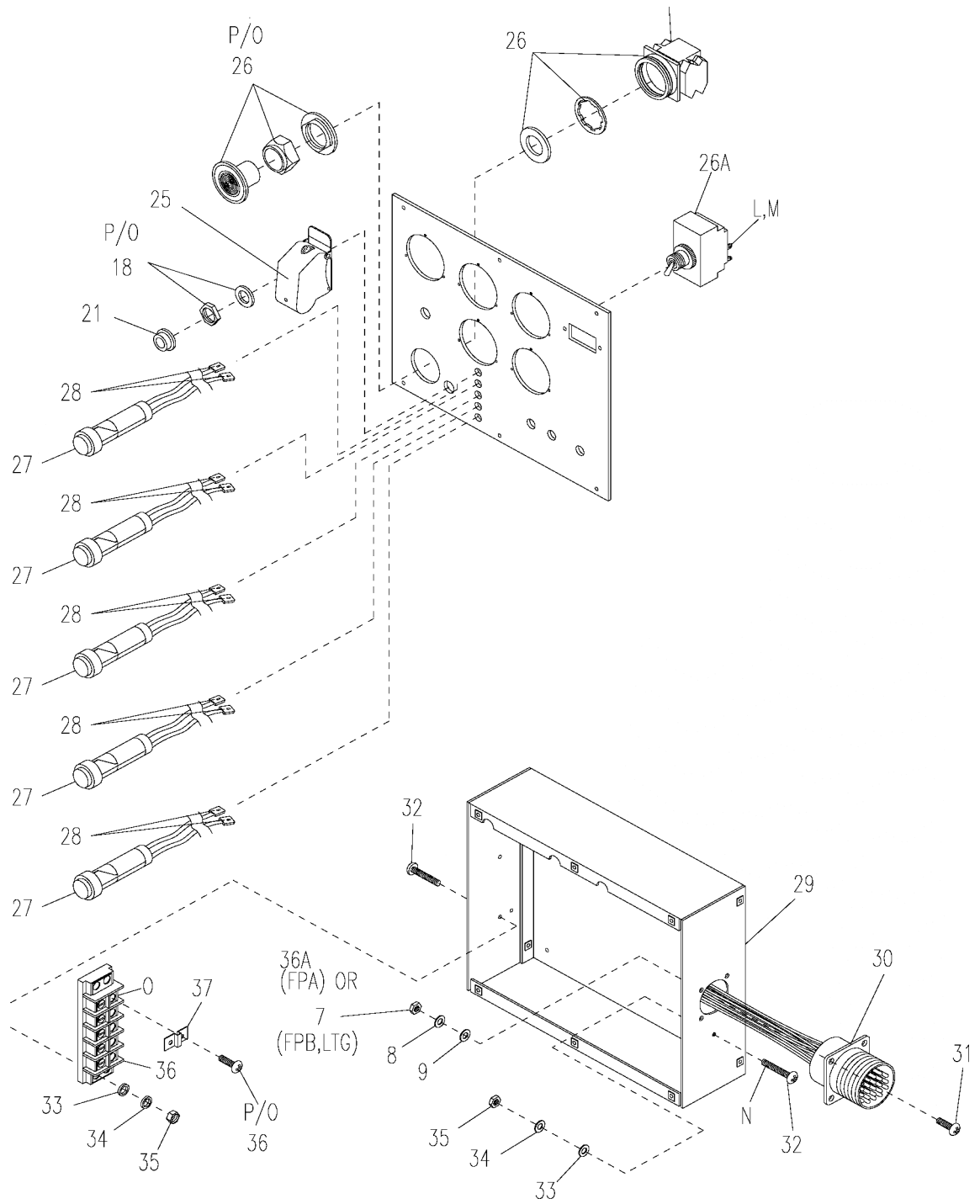

Figure C-27. APU Control Box Assembly (Sheet 2 of 3)

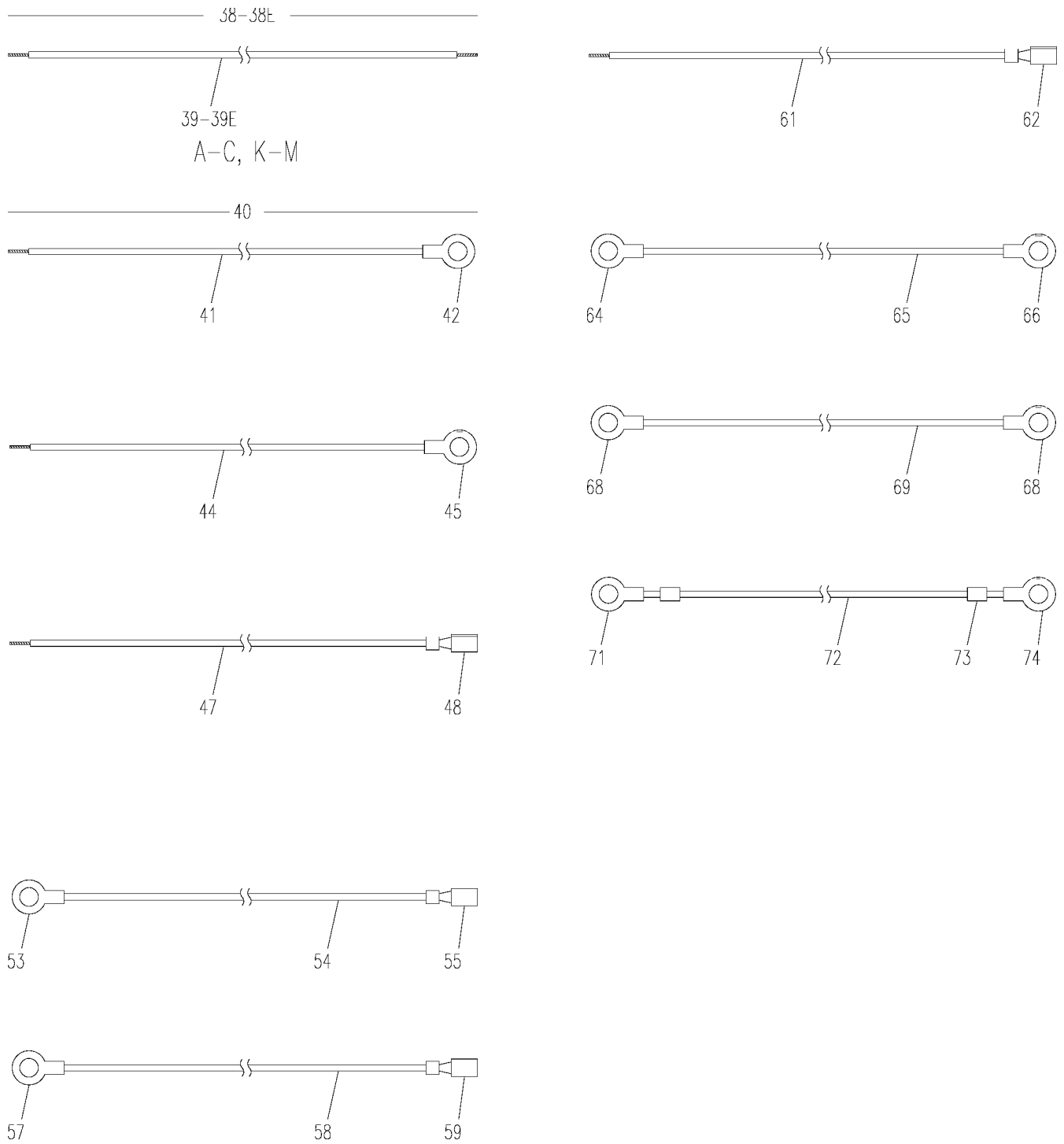

Figure C-27. APU Control Box Assembly (Sheet 3 of 3)

Section II.

ARMY TM 9-6115-670-14&P

(1) Item No	(2) SMR CODE	(3) NSN	(4) CAGEC	(5) Part Number	(6) Description and Usable on Code (UOC)	(7) QTY
GROUP 03 APU CONTROL BOX ASSY						
FIG C-27						
1	XBOZZA		97403	13230E6221	COVER, CONTROL BOX..... UOC: FPB, ABC, LTG	1
1	XBFZZA		29381	4210004D	COVER, CONTROL BOX..... UOC: FPA	1
2	PAOZZA	5310-01-478-6346	30554	88-20033-19C	WASHER, FLAT..... UOC: FPB, ABC, LTG	16
3	PAOZZA	5310-00-933-8121	97403	13230E6744-139	WASHER, LOCK..... UOC: FPB, ABC, LTG	16
4	PAOZZA	5310-00-400-5503	96906	MS35650-3254	NUT, PLAIN, HEXAGON..... UOC: FPB, ABC, LTG	16
5	XBOZZA		97403	13230E6245-4	PLUG, PLASTIC..... UOC: FPB, ABC, LTG	8
5	XBFZZA		29381	1531011A	PLUG, PLASTIC..... UOC: FPA	8
6	PAOZZA	5310-00-903-8595	78553	C7931-1032-3B	NUT, PLAIN, CLINCH..... UOC: FPB, ABC, LTG	10
6	PAOZZA	5325-01-500-5761	29381	1224201A	INSERT, FASTNER..... UOC: FPA	10
7	PAOZZA	5310-00-934-9761	96906	MS35649-264	NUT, PLAIN, HEXAGON..... UOC: FPB, ABC, LTG	6
8	PAOZZA	5310-00-929-6395	80205	MS35338-136	WASHER, LOCK..... UOC: FPB, ABC, LTG	6
9	PAOZZA	5310-01-478-6344	30554	88-20033-5C	WASHER, FLAT..... UOC: FPB, ABC, LTG	6
10	PAOZZA	5305-01-479-1843	97403	13218E0493-2770P	SCREW, MACHINE..... UOC: FPB, ABC, LTG	10
10	PAOZZA	5305-01-500-6912	29381	1434011A	SCREW, MACHINE..... UOC: FPA	10
11	PAOZZA	5305-01-479-1845	97403	13218E0493-1289P	SCREW, MACHINE..... UOC: FPB, ABC, LTG	2
12	PAOZZA	6645-01-369-2478	74400	85000	METER, TIME TOTALIZI..... UOC: FPB, FPA, ABC, LTG	1
13	PAOZZA	6625-01-478-5172	97403	13230E6224	METER, ELECTRICAL FR..... UOC: FPB, FPA, ABC, LTG	1
14	PAOZZA	6625-01-478-5163	97403	13230E6223	AMMETER..... UOC: FPB, FPA, ABC, LTG	1
15	PAOZZA	6625-01-478-5158	97403	13230E6222	VOLTMETER..... UOC: FPB, FPA, ABC, LTG	1
16	PAFZZA	5355-01-478-8487	97403	13230E6678-3	KNOB..... UOC: FPB, FPA, ABC, LTG	1
16A	XBFZZA		29381	9830005A	PLATE, VOLTAGE ADJUS..... UOC: FPA	1
17	PAOZZA	5905-01-087-1910	18876	P12934-010-01	RESISTOR, VARIABLE, W..... UOC: FPB, ABC, LTG	1
17	PAFZZA	5905-01-501-2913	29381	2372002A	RESISTOR, VARIABLE..... UOC: FPA	1
18	PAFZZA	5930-00-540-8311	96906	MS27735-23	SWITCH, TOGGLE..... UOC: FPB, ABC, LTG	2
18	PAFZZA	5930-01-500-9303	29381	2351003A	SWITCH, TOGGLE..... UOC: FPA	2
19	PAOZZA	5930-01-478-5114	97403	13230E6278	SWITCH, TOGGLE..... UOC: FPB, ABC, LTG	1
19	PAFZZA	5930-01-500-9299	29381	2351004A	SWITCH, TOGGLE..... UOC: FPA	1
20	PAOZZA	5930-01-478-5110	97403	13230E6255	GUARD, SWITCH..... UOC: FPB, FPA, ABC, LTG	1
21	PAOZZA	5930-00-539-7013	81349	M5423/02-01	BOOT, DUST AND MOIST..... UOC: FPB, FPA, ABC, LTG	4

Section II.

TM 9-6115-670-14&P

(1) Item No	(2) SMR CODE	(3) NSN	(4) CAGEC	(5) Part Number	(6) Description and Usable on Code (UOC)	(7) QTY
GROUP 03 APU CONTOL BOX ASSY						
FIG C-27						
19	PAOZZA	5930-01-478-5114	97403	13230E6278	SWITCH, TOGGLE UOC: FPB, ABC, LTG	1
19	PAFZZA	5930-01-500-9299	29381	2351004A	SWITCH, TOGGLE UOC: FPA	1
20	PAOZZA	5930-01-478-5110	97403	13230E6255	GUARD, SWITCH UOC: FPB, FPA, ABC, LTG	1
21	PAOZZA	5930-00-539-7013	81349	M5423/02-01	BOOT, DUST AND MOIST UOC: FPB, FPA, ABC, LTG	4
22	PAOZZA	6685-01-486-1376	97403	13230E6244	GAUGE, WATER TEMPERA UOC: FPB, FPA, ABC, LTG	1
23	PAOZZA	5905-01-478-8109	97403	13230E6233	RESISTOR ASSEMBLY UOC: FPB, FPA, ABC, LTG	1
24	PAOZZA	6625-01-478-5168	97403	13230E6225	AMMETER UOC: FPB, FPA, ABC, LTG	1
25	PAOZZA	5930-00-615-6731	96906	MS25224-1	GUARD, SWITCH UOC: FPB, ABC, LTG	1
26	PAOZZA	5930-01-155-0768	51917	9001KR9RH8	SWITCH, PUSH-PULL UOC: FPB, FPA, ABC, LTG	1
26A	PAFZZA	5930-00-540-8311	96906	MS27735-23	SWITCH, TOGGLE UOC: FPB, ABC, LTG	1
26A	PAFZZA	5930-01-500-9305	29381	2351002A	SWITCH, TOGGLE UOC: FPA	1
27	PAOZZA	6210-01-478-6973	97403	13230E6229	LAMP, INCANDESCENT UOC: LTG, FPB, FPA, ABC	5
28	PAFZZA	5940-00-557-1629	96906	MS25036-149	TERMINAL, LUG UOC: FPB, ABC, LTG	10
29	XBOZZA		97403	13230E6227	PANEL, CONTROL BOX UOC: FPB, ABC, LTG	1
29	XBFZZA		29381	4210005C	PANEL, CONTROL BOX UOC: FPA	1
30	XBOFFA		97403	13230E6235	WIRING HARNESS, J2 SEE FIGURE C-28 FOR BREAKDOWN UOC: FPB, ABC, LTG	1
30	XBOFFA		29381	2233009D	WIRING HARNESS, J2 SEE FIGURE C-28 FOR BREAKDOWN UOC: FPA	1
31	PAOZZA	5305-01-479-1846	97403	13218E0493-1287P IIC	SCREW, MACHINE UOC: FPB, ABC, LTG	4
31	PAOZZA	5305-01-500-6554	29381	1454007A	SCREW, CAP, HEAD UOC: FPA	7
32	PAOZZA	5305-01-479-0551	30554	8820042-57A	SCREW, MACHINE UOC: FPB, ABC, LTG	5
32	PAOZZA	5305-01-500-7231	29381	1424011A	SCREW, MACHINE UOC: FPA	1
33	PAOZZA	5310-01-478-6341	30554	88-20033-11B	WASHER, FLAT UOC: FPB, ABC, LTG	6
33	PAOZZA	5310-01-500-6113	29381	1315001A	WASHER, FLAT UOC: FPA	2
34	PAOZZA	5310-01-478-5772	97403	13230E6744-100	WASHER, LOCK UOC: FPB, ABC, LTG	6
34	PAOZZA	5310-01-500-6092	29381	1332100A	WASHER, LOCK UOC: FPA	2
35	PAOZZA	5310-01-478-9244	97403	13218E0320-129	NUT, PLAIN, HEXAGON UOC: FPB, FPA, ABC, LTG	6
36	PAOZZA	5940-01-422-3634	81349	39TB08F	TERMINAL BOARD UOC: LTG, FPB, ABC	1

Section II.

ARMY TM 9-6115-670-14&P

(1) Item No	(2) SMR CODE	(3) NSN	(4) CAGEC	(5) Part Number	(6) Description and Usable on Code (UOC)	(7) QTY
GROUP 03 APU CONTOL BOX ASSY						
FIG C-27						
36A	PAOZZA	5310-01-500-6179	29381	1224017A	NUT, SELF-LOCKING, AS..... UOC: FPA	7
37	PAOZZA	5310-00-052-3632	30554	69-561-3	NUT, PLAIN, ASSEMBLED..... UOC: FPB, ABC, LTG	2
38	MFFZZA		97403	13230E6232-14	LEAD, ELECTRICAL..... UOC: FPB, ABC, LTG	1
38A	MFFZZA		97403	13230E6232-9	LEAD, ELECTRICAL..... UOC: FPB, ABC, LTG	1
38B	MFFZZA		97403	13230E6232-13	LEAD, ELECTRICAL..... UOC: FPB, ABC, LTG	1
38C	MFFZZA		97403	13230E6232-12	LEAD, ELECTRICAL..... UOC: FPB, ABC, LTG	1
38D	MFFZZA		97403	13230E6232-10	LEAD, ELECTRICAL..... UOC: FPB, ABC, LTG	1
38E	MFFZZA		97403	13230E6232-8	LEAD, ELECTRICAL..... UOC: FPB, ABC, LTG	1
39	MFFZZA		97403	13230E6653-4-11I	WIRE, ELECTRICAL MAKE FROM NCH WIRE, ELECTRICAL (97403)13230E6653-4;11 IN S..... UOC: FPB, ABC, LTG	1
39A	MFFZZA		97403	13230E6653-4-11I	WIRE, ELECTRICAL MAKE FROM NCH WIRE, ELECTRICAL (97403)13230E6653-4;11 IN S..... UOC: FPB, ABC, LTG	1
39B	MFFZZA		97403	13230E6653-4-11I	WIRE, ELECTRICAL MAKE FROM NCH WIRE, ELECTRICAL (97403)13230E6653-4;11 IN S..... UOC: FPB, ABC, LTG	1
39C	MFFZZA		97403	13230E6653-4-1IN	WIRE, ELECTRICAL MAKE FROM CH WIRE, ELECTRICAL (97403)13230E6653-4;1 INC..... UOC: FPB, ABC, LTG	1
39D	MFFZZA		97403	13230E6653-4-6IN	WIRE, ELECTRICAL MAKE FROM CH WIRE, ELECTRICAL (97403)13230E6653-4;6 INC..... UOC: FPB, ABC, LTG	1
39E	MFFZZA		97403	13230E6653-4-2IN	WIRE, ELECTRICAL MAKE FROM CH WIRE, ELECTRICAL (97403)13230E6653-4;2 INC..... UOC: FPB, ABC, LTG	1
40	MFFZZA		97403	13230E6232-7	LEAD, ELECTRICAL..... UOC: FPB, ABC, LTG	1
41	MFFZZA		97403	13230E6653-4-4IN	WIRE, ELECTRICAL MAKE FROM CH WIRE, ELECTRICAL (97403)13230E6653-4;4 INC..... UOC: FPB, ABC, LTG	1
42	PAFZZA	5940-00-143-4771	96906	MS25036-103	TERMINAL, LUG..... UOC: FPB, ABC, LTG	1
43	MFFZZA		29381	2231009B	LEAD, ELECTRICAL..... UOC: FPA	1
44	MFFZZA		97403	13230E6653-4-5.2	WIRE, ELECTRICAL MAKE FROM 5 INCH WIRE, ELECTRICAL (97403)13230E6653-4;5.25 HES..... UOC: FPA	1
45	PAFZZA	5940-00-143-4771	96906	MS25036-103	TERMINAL, LUG..... UOC: FPA	1

Section II.

ARMY TM 9-6115-670-14&P

(1) Item No	(2) SMR CODE	(3) NSN	(4) CAGEC	(5) Part Number	(6) Description and Usable on Code (UOC)	(7) QTY
					GROUP 03 APU CONTOL BOX ASSY	
					FIG C-27	
46	MFZZA		97403	13230E6232-6	LEAD, ELECTRICAL..... UOC:FPB,ABC,LTG	1
47	MFZZA		97403	13230E6653-4-4.5	WIRE, ELECTRICAL MAKE FROM INCH WIRE, ELECTRICAL (97403)13230E6653-4;4.5 I ES..... UOC:FPB,ABC,LTG	1
48	PAFZZA	5940-01-052-7646	14726	S05300F	TERMINAL, QUICK DISC..... UOC:FPB,ABC,LTG	1
49	MFZZA		29381	2231010D	LEAD, ELECTRICAL..... UOC:FPA	1
50	MFZZA		97403	13230E6653-4-18I	WIRE, ELECTRICAL MAKE FROM NCH WIRE, ELECTRICAL (97403)13230E6653-4;18 IN S..... UOC:FPA	1
51	PAFZZA	5940-01-052-7646	14726	S05300F	TERMINAL, QUICK DISC..... UOC:FPA	1
52	MFZZA		97403	13230E6232-3	LEAD, ELECTRICAL..... UOC:FPB,ABC,LTG	1
52	MFZZA		29381	2231007C	LEAD, ELECTRICAL..... UOC:FPA	1
53	PAFZZA	5940-00-143-4771	96906	MS25036-103	TERMINAL, LUG..... UOC:FPB,ABC,LTG	1
53	PAFZZA	5940-00-143-4771	96906	MS25036-103	TERMINAL, LUG..... UOC:FPA	1
54	MFZZA		97403	13230E6653-4-6IN	WIRE, ELECTRICAL MAKE FROM CH WIRE, ELECTRICAL (97403)13230E6653-4;6 INC..... UOC:FPB,ABC,LTG	1
54	MFZZA		97403	13230E6653-4-6IN	WIRE, ELECTRICAL MAKE FROM CH WIRE, ELECTRICAL (97403)13230E6653-4;6 INC..... UOC:FPA	1
55	PAFZZA	5940-01-052-7646	14726	S05300F	TERMINAL, QUICK DISC..... UOC:FPB,ABC,LTG	1
55	PAFZZA	5940-01-052-7646	14726	S05300F	TERMINAL, QUICK DISC..... UOC:FPA	1
56	MFZZA		97403	13230E6232-4	LEAD, ELECTRICAL..... UOC:FPB,ABC,LTG	1
56	MFZZA		29381	2231008C	LEAD, ELECTRICAL..... UOC:FPA	1
57	PAFZZA	5940-00-143-4771	96906	MS25036-103	TERMINAL, LUG..... UOC:FPB,ABC,LTG	1
57	PAFZZA	5940-00-143-4771	96906	MS25036-103	TERMINAL, LUG..... UOC:FPA	1
58	MFZZA		97403	13230E6653-4-7IN	WIRE, ELECTRICAL MAKE FROM CH WIRE, ELECTRICAL (97403)13230E6653-4;7 INC..... UOC:FPB,ABC,LTG	1
58	MFZZA		97403	13230E6653-4-8.5	WIRE, ELECTRICAL MAKE FROM INCH WIRE, ELECTRICAL (97403)13230E6653-4;8.5 I ES..... UOC:FPA	1
59	PAOZZA	5940-01-052-7646	14726	S05300F	TERMINAL, QUICK DISC..... UOC:FPB,ABC,LTG	1
59	PAFZZA	5940-01-052-7646	14726	S05300F	TERMINAL, QUICK DISC..... UOC:FPA	1

Section II.

ARMY TM 9-6115-670-14&P

(1) Item No	(2) SMR CODE	(3) NSN	(4) CAGEC	(5) Part Number	(6) Description and Usable on Code (UOC)	(7) QTY
					GROUP 03 APU CONTOL BOX ASSY	
					FIG C-27	
60	MFZZA		97403	13230E6232-5	LEAD, ELECTRICAL..... UOC:FPB,ABC,LTG	1
60	MFZZA		29381	2231006C	LEAD, ELECTRICAL..... UOC:FPA	1
61	MFZZA		97403	13230E6653-4-8IN	WIRE, ELECTRICAL MAKE FROM CH WIRE, ELECTRICAL (97403)13230E6653-4;8 INC..... UOC:FPB,ABC,LTG	1
61	MFZZA		97403	13230E6653-4-6.7	WIRE, ELECTRICAL MAKE FROM 5INCH WIRE, ELECTRICAL (97403)13230E6653-4;6.75 HES..... UOC:FPA	1
62	PAFZZA	5940-01-052-7646	14726	S05300F	TERMINAL, QUICK DISC..... UOC:FPB,ABC,LTG	1
62	PAFZZA	5940-01-052-7646	14726	S05300F	TERMINAL, QUICK DISC..... UOC:FPA	1
63	MFZZA		97403	13230E6232-1	LEAD, ELECTRICAL..... UOC:FPB,ABC,LTG	1
63	MFZZA		29381	2231005D	LEAD, ELECTRICAL..... UOC:FPA	1
64	PAFZZA	5940-00-143-4771	96906	MS25036-103	TERMINAL, LUG..... UOC:FPB,ABC,LTG	1
64	PAFZZA	5940-01-503-8274	29381	2111008A	TERMINAL, LUG..... UOC:FPA	2
65	MFZZA		97403	13230E6653-4-8IN	WIRE, ELECTRICAL MAKE FROM CH WIRE, ELECTRICAL (97403)13230E6653-4;8 INC..... UOC:FPB,ABC,LTG	1
65	MFZZA		97403	13230E6653-4-7.2	WIRE, ELECTRICAL MAKE FROM 5INCH WIRE, ELECTRICAL (97403)13230E6653-4;7.25 HES..... UOC:FPA	1
66	PAFZZA	5940-00-113-8184	96906	MS25036-150	TERMINAL, LUG..... UOC:FPB,ABC,LTG	1
67	MFZZA		97403	13230E6232-2	LEAD, ELECTRICAL..... UOC:FPB,ABC,LTG	1
68	PAFZZA	5940-00-113-8184	96906	MS25036-150	TERMINAL, LUG..... UOC:FPB,ABC,LTG	2
69	MFZZA		97403	13230E6653-4-8IN	WIRE, ELECTRICAL MAKE FROM CH WIRE, ELECTRICAL (97403)13230E6653-4;8 INC..... UOC:FPB,ABC,LTG	1
70	MFZZA		29381	2231040A	LEAD, ELECTRICAL..... UOC:FPA	1
71	PAFZZA	5940-00-143-4771	96906	MS25036-103	TERMINAL, LUG..... UOC:FPA	1
72	MFZZA		97403	13230E6653-4-7.2	WIRE, ELECTRICAL MAKE FROM 5INCH WIRE, ELECTRICAL (97403)13230E6653-4;7.25 HES..... UOC:FPA	1
73	PAOZZA		29381	2219026A	MARKER, WIRE..... UOC:FPA	2
74	PAFZZA	5940-01-503-8274	29381	2111008A	TERMINAL, LUG..... UOC:FPA	1
75	MFZZA		97403	13230E6232-11Z	LEAD, ELECTRICAL..... UOC:FPB,ABC,LTG	1

Section II.

ARMY TM 9-6115-670-14&P

(1) Item No	(2) SMR CODE	(3) NSN	(4) CAGEC	(5) Part Number	(6) Description and Usable on Code (UOC)	(7) QTY
					GROUP 03 APU CONTOL BOX ASSY	
					FIG C-27	
76	MFFZZA		97403	13230E6653-4-15.	WIRE,ELECTRICAL MAKE FROM 5INCH WIRE,ELECTRICAL (97403)13230E6653-5;15.5 HES..... UOC:FPB,ABC,LTG	1

End of Figure

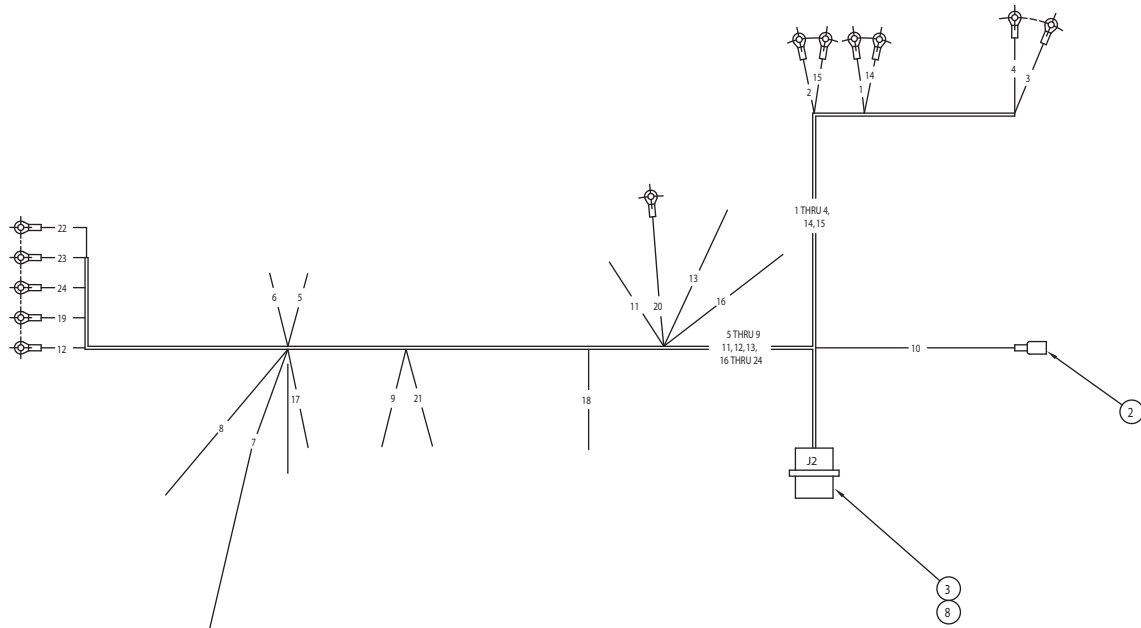

WIRE NO.	TERMINATION		TERMINATION		WIRE FIND NO.
	FROM	FIND NO.	TO	FIND NO.	
1	J2-A	3	ACA	1	6
2	J2-B	3	ACA+	1	6
3	J2-C	3	ACV	1	6
4	J2-D	3	ACV+	1	6
5	J2-E	3	P2	-	6
6	J2-F	3	P3	-	6
7	J2-G	3	AUX1	-	6
8	J2-H	3	AUX2	-	6
9	J2-J	3	BSS3	-	6
10	J2-K	3	WTRS	2	6
11	J2-L	3	ACS2	-	6
12	J2-M	3	TB1-1	5	6
13	J2-N	3	SPS1	-	6
14	J2-P	3	DCA	1	6
15	J2-Q	3	DCA+	1	6
16	J2-R	3	SPS4	-	6
17	J2-S	3	ESS1	-	6
18	J2-T	3	MOOS5	-	6
19	J2-U	3	TB1-2	5	6
20	J2-V	3	GND	4	6
21	J2-W	3	BSS4	-	6
22	J2-X	3	TB1-5	5	6
23	J2-Y	3	TB1-4	5	6
24	J2-Z	3	TB1-3	5	6

Figure C-28. Wiring Harness, J2 (Sheet 1 of 2)

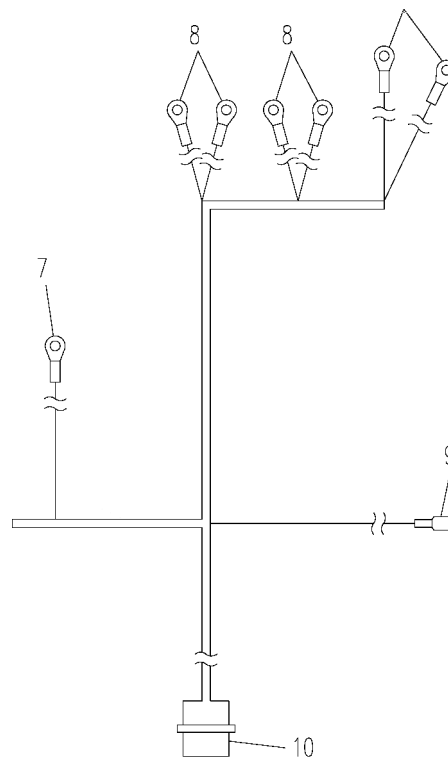

JTACS
(FPA)

INSTRUCTIONS

ITEM #	WIRE SIZE	CUT LENGTH	TAG	TERMINATION
1	18 GA	10"	ACA/A	2111008A
2	18 GA	8.75"	ACA/B	2111008A
3	18 GA	12.25"	ACA/C	2111008A
4	18 GA	11"	ACV/D	2111008A
5	18 GA	11.75"	P2/E	TIN
6	18 GA	11.75"	P3/F	TIN
7	18 GA	11.0"	BSS5/J	TIN
8	18 GA	5"	WTS/K	13230E6231-1
9	18 GA	6"	ACS3/L	TIN
10	18 GA	13.5"	V-/M	TIN
11	18 GA	8"	SPS1/N	TIN
12	18 GA	8.75"	DCA/P	2111008A
13	18 GA	8"	DCAS/Q	2111008A
14	18 GA	8"	SPS4/R	TIN
15	18 GA	12.0"	ESS1/S	TIN
16	18 GA	8.5"	MOOS4/T	TIN
17	18 GA	13.5"	S-/U	TIN
18	18 GA	6"	GND/V	13217E3854-2
19	18 GA	11.5"	BSS2/W	TIN
20	18 GA	13.5"	O-/X	TIN
21	18 GA	13.5"	W-/Y	TIN
22	18 GA	13.5"	F-/Z	TIN
23	18 GA	15"	AUX1/G	TIN
24	18 GA	14"	AUX2/H	TIN

Figure C-28. Wiring Harness, J2 (Sheet 2 of 2)

Section II.

ARMY TM 9-6115-670-14&P

(1) Item No	(2) SMR CODE	(3) NSN	(4) CAGEC	(5) Part Number	(6) Description and Usable on Code (UOC)	(7) QTY
GROUP 0301 WIRING HARNESS J2						
FIG C-28						
1	PAFZZA	5940-00-143-4774	96906	MS25036-153	TERMINAL,LUG..... UOC:FPP,ABC,LTG	5
2	PAFZZA	5940-00-143-4780	96906	MS25036-108	TERMINAL,LUG..... UOC:FPP,ABC,LTG	1
3	PAFZZA	5940-00-230-0515	97403	13226E0107-14	TERMINAL,LUG..... UOC:FPP,ABC,LTG	6
4	PAFZZA	5940-01-082-3321	00779	3-350820-2	TERMINAL,QUICK DISC..... UOC:FPP,ABC,LTG	1
5	PAFZZA	5935-01-110-1942	96906	MS3452W24-28P	CONNECTOR,RECEPTACL..... UOC:FPP,ABC,LTG	1
6	XBFZZA	5975-00-111-3208	81343	MS3367-5-9	STRAP,TIEDOWN,ELECT..... UOC:FPP,ABC,LTG	V
7	PAFZZA	5940-00-143-4771	96906	MS25036-103	TERMINAL,LUG..... UOC:FPA	1
8	PAFZZA	5940-01-503-8274	29381	2111008A	TERMINAL,LUG..... UOC:FPA	6
9	PAFZZA	5940-01-052-7646	14726	S05300F	TERMINAL,QUICK DISC..... UOC:FPA	1
10	PAFZZA	5935-01-500-6843	29381	2160002A	CONNECTOR,RECEPTACL..... UOC:FPA	1

End of Figure

Section II.

ARMY TM 9-6115-670-14&P

(1) Item No	(2) SMR CODE	(3) NSN	(4) CAGEC	(5) Part Number	(6) Description and Usable on Code (UOC)	(7) QTY
GROUP 99 BULK MATERIALS						
FIG BULK						
1	PAOZZA	4720-00-005-5008	98441	208-3	HOSE, NONMETALLIC..... UOC:FPB, FPA, ABC, LTG	1
2	PAOZZA	4720-01-470-6230	30554	88-20579-4	HOSE, NONMETALLIC..... UOC:FPB, FPA, ABC, LTG	1
3	PAFZZA	5306-00-314-7352	81346	ASTMA484	ROD, CONTINUOUS THRE..... UOC:FPB, ABC, LTG	1
4	PAFZZA	5330-01-479-0531	4X687	030-02813	SEAL, NONMETALLIC CH..... UOC:FPB, ABC, LTG	1
5	PAFZZA	9390-01-480-2555	97403	13230E6292-2	NONMETALLIC CHANNEL..... UOC:FPB, ABC, LTG	1
6	PAFZZA	9390-00-872-2219	70485	X-1054	NONMETALLIC CHANNEL..... UOC:FPB, ABC, LTG	1
7	PAOZZA	4720-01-179-2479	98441	243001-10-0380	HOSE ASSEMBLY, NONME..... UOC:LTG	1
8	PAFZZA	9390-01-500-3066	29381	4732020A	MOLDING, PLASTOC..... UOC:FPA	1
9	PAFZZA	5325-01-500-5762	29381	1513006A-20	GROMMET, NONMETALLIC..... UOC:FPA	1
10	PAFZZA		97403	13230E6820-1	LOOM, PLASTIC FLEX..... UOC:FPB, FPA, ABC, LTG	1
11	XBFZZA		97403	13230E6888	CABLE, MULTICON W/SH..... UOC:FPB, FPA, ABC, LTG	1
12	XBOZZA		29381	4722253	ROD, THREADED..... UOC:FPA	1
13	PAOZZA	6145-01-060-7863	D2733	R61AWG18/19-9	WIRE, ELECTRICAL..... UOC:FPB, FPA, ABC, LTG	1
14	PAOZZA	6145-01-044-8799	81349	M22759/16-16-9	WIRE, ELECTRICAL..... UOC:FPB, FPA, ABC, LTG	1
15	PAOZZA	6145-01-060-7868	81349	M22759/16-12-9	WIRE, ELECTRICAL..... UOC:FPB, FPA, ABC, LTG	1
16	PAOZZA	6145-01-060-7869	81349	M22759/16-10-9	WIRE, ELECTRICAL..... UOC:FPB, FPA, ABC, LTG	1
17	PAOZZA	9320-00-787-6516	81349	M3AA414BC1	RUBBER STRIP..... UOC:FPB, FPA, ABC, LTG	1
18	PAFZZA	5975-01-500-7275	97403	13230E6820-3	CONDUIT, NONMETALLIC..... UOC:FPB, FPA, ABC, LTG	1
19	PAFZZA	5975-01-500-7273	97403	13230E6820-4	CONDUIT, NONMETALLIC..... UOC:FPB, FPA, ABC, LTG	1
20	PAOZZA	6145-00-220-9660	58536	AA59569R36T0500	BRAID, WIRE..... UOC:ABC	1
21	PAOZZA		81349	MIL-H-13444-TYI-0.19	HOSE, NONMETALLIC..... UOC:ABC	1
22	PAOZZA		28105	ST-301-3/8 BLACK	INSULATION SLEEVING..... UOC:ABC	1
23	PAOZZA	6145-00-728-4026	74116	NEQ241636T	BRAID, WIRE..... UOC:ABC	11
24	PAOZZA	6145-00-548-2925	58536	AA59569R36T0781	BRAID, WIRE..... UOC:ABC	1

End of Figure

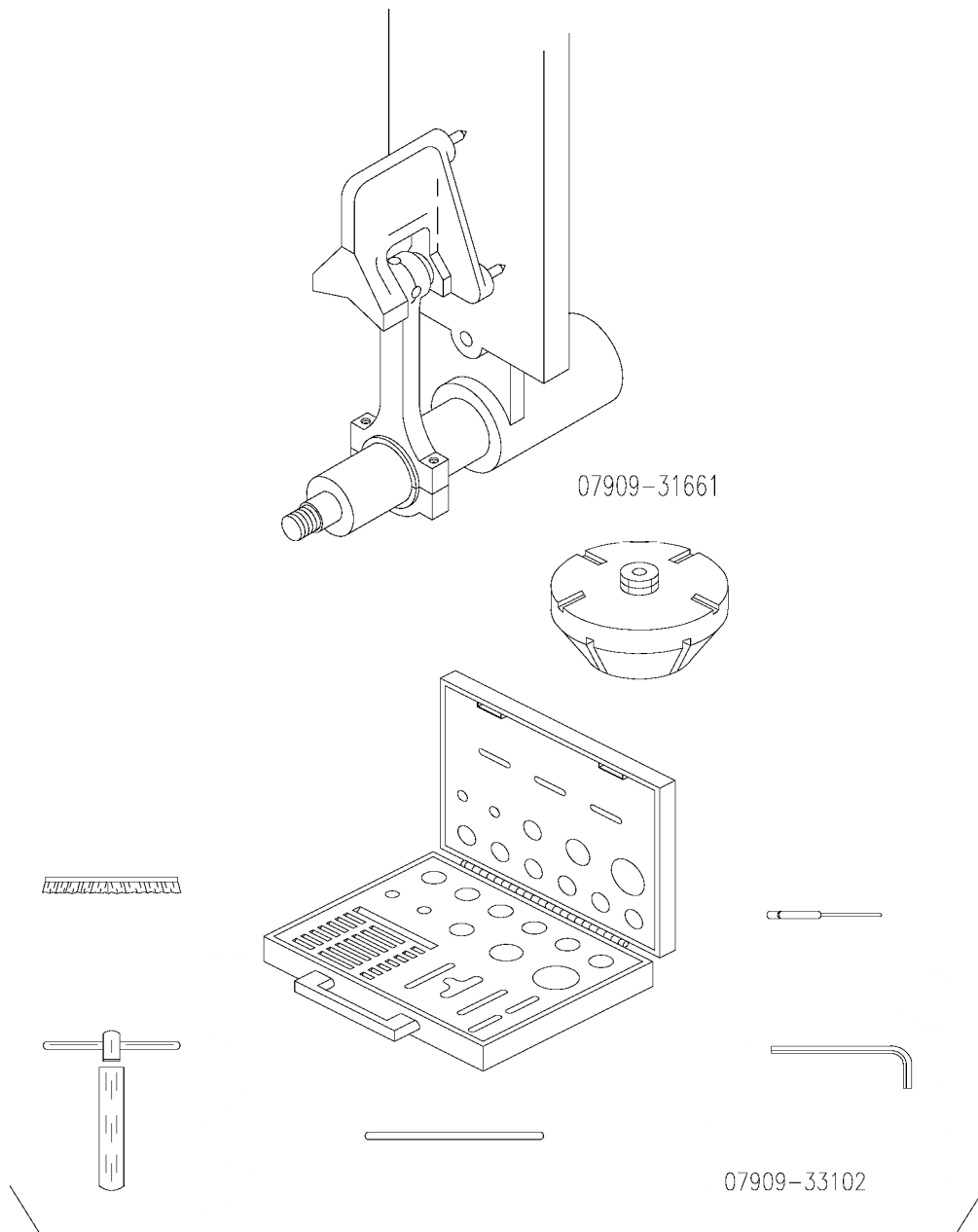
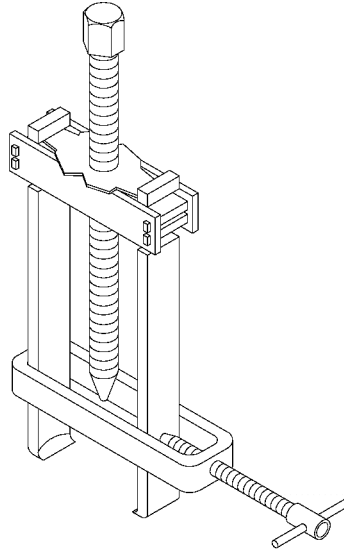
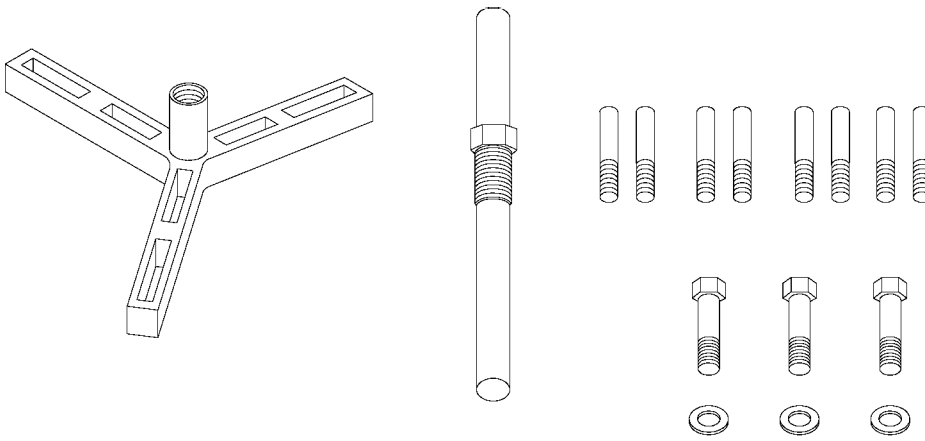

Figure C-29. Special Tools (Sheet 1 of 6)



07916-09032



07916-32011

Figure C-29. Special Tools (Sheet 2 of 6)

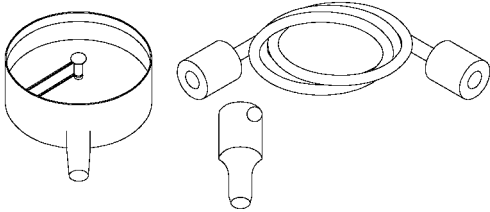
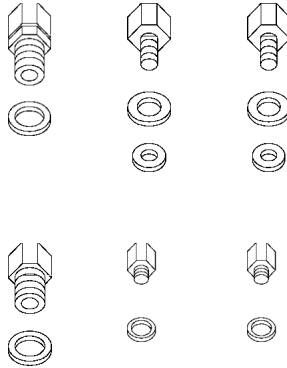
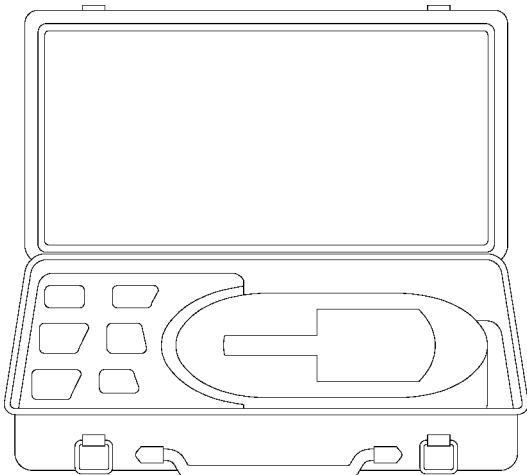

07916-32032

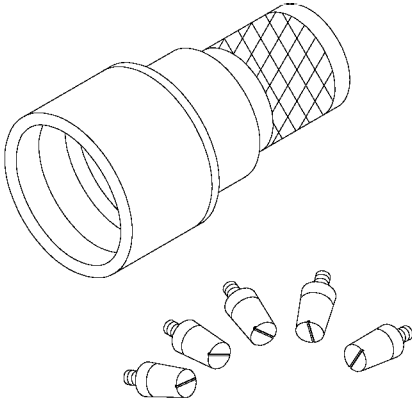

07916-34041

Figure C-29. Special Tools (Sheet 3 of 6)



K1ST 10030A

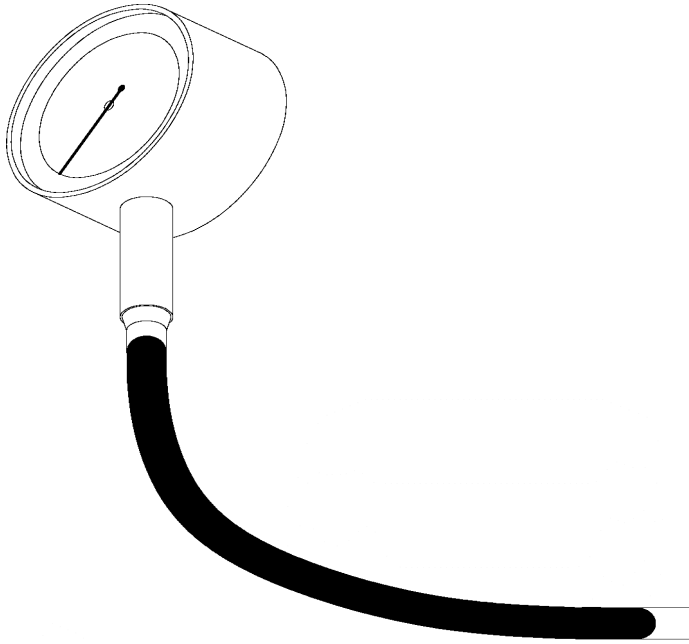

K1ST 10060-G

Figure C-29. Special Tools (Sheet 4 of 6)

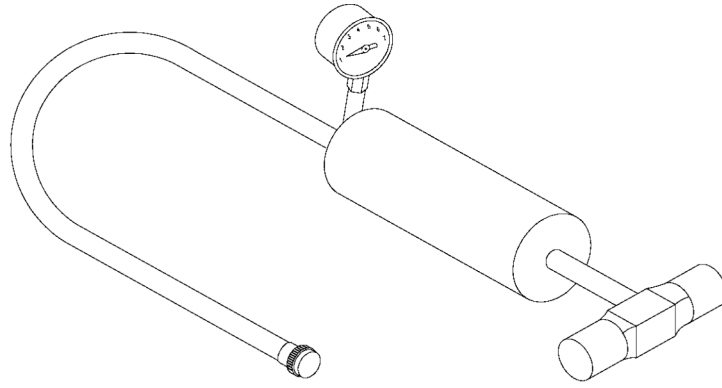

K1ST 10080

9

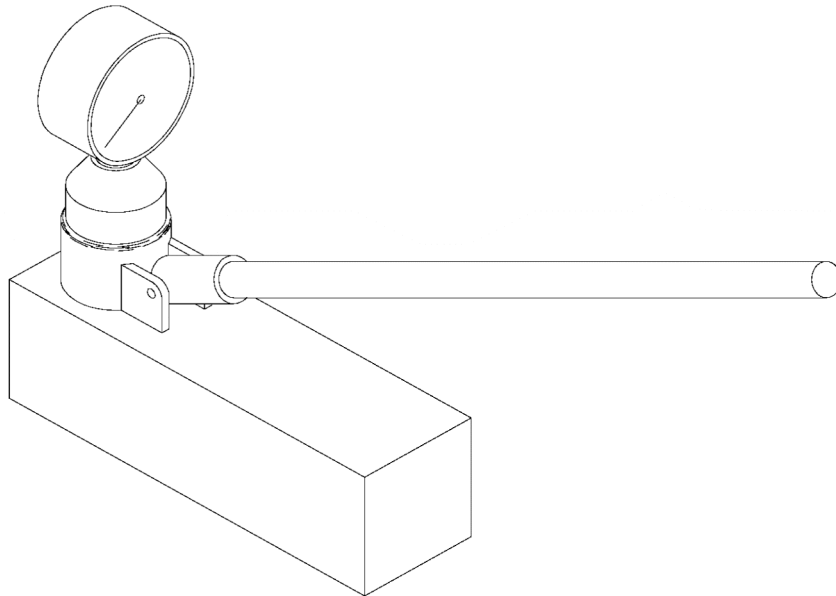

K1ST 20010

10

Figure C-29. Special Tools (Sheet 5 of 6)

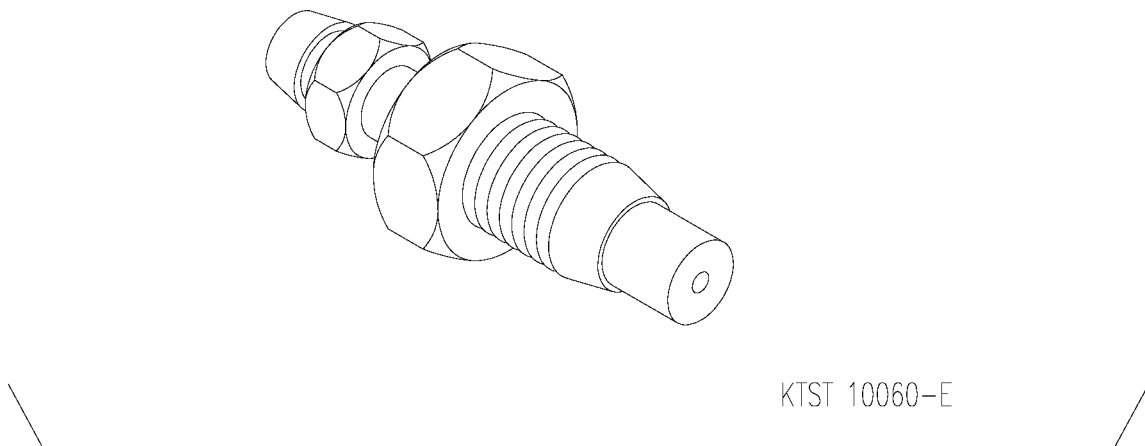
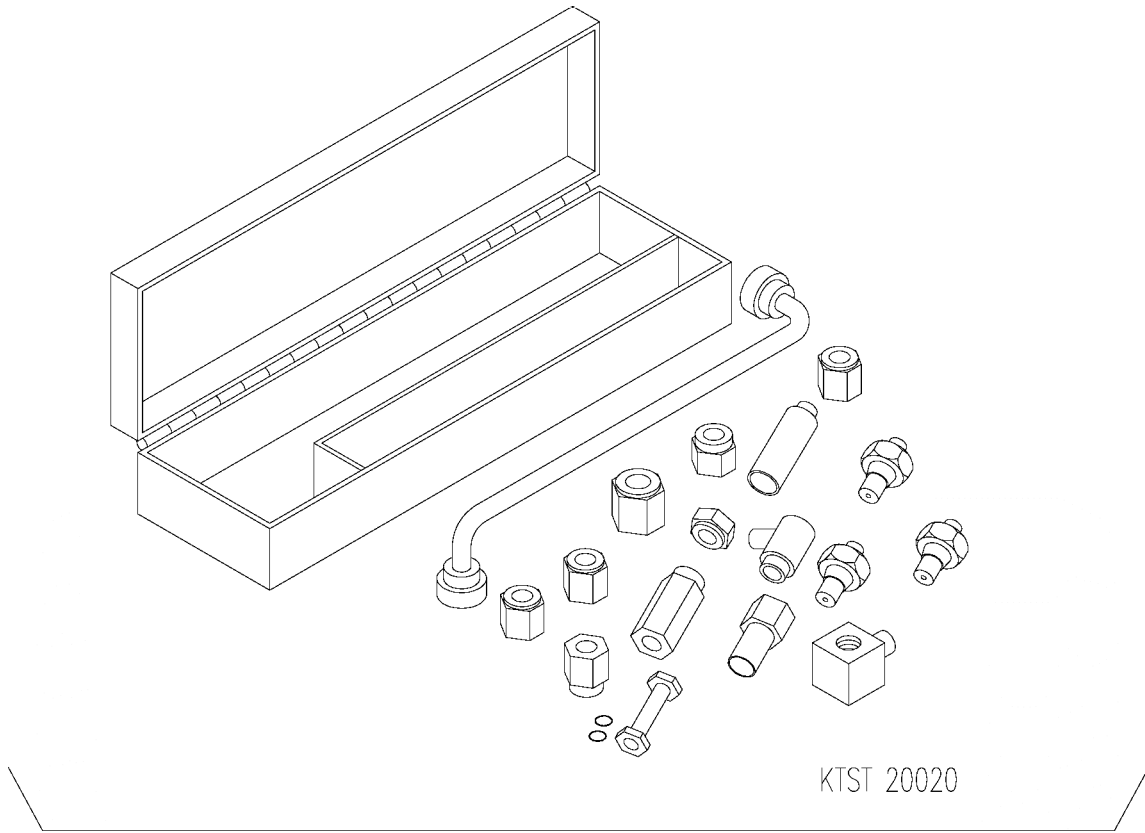

Figure C-29. Special Tools (Sheet 6 of 6)

Section III.

ARMY TM 9-6115-670-14&P

(1) Item No	(2) SMR CODE	(3) NSN	(4) CAGEC	(5) Part Number	(6) Description and Usable on Code (UOC)	(7) QTY
GROUP 100 SPECIAL TOOLS						
FIG C-29						
1	PAHZZA	5120-01-479-5832	0XWR1	07909-31661	ALIGNING TOOL,ROTAT..... BOI: 0 Per End Items	1
2	PAHZZA	5180-01-500-1548	0XWR1	07909-33102	TOOL KIT,VALVE SEAT..... BOI: 0 Per End Items	1
3	PAHZZA	5120-01-486-5065	0XWR1	07916-09032	PULLER,MECHANICAL..... BOI: 0 Per End Items	1
4	PAFZZA	5120-01-500-7213	0XWR1	07916-32011	PULLER SET,MECHANIC..... BOI: 0 Per End Items	1
5	PAHZZA	6685-01-486-0361	0XWR1	07916-32032	GAGE,PRESSURE,DIAL,..... BOI: 0 Per End Items	1
6	PAHZZA	5120-01-G72-6948	0XWR1	07916-34041	RETAINER,SLEEVE,SEA..... BOI: 0 Per End Items	1
7	PAHZZA	5110-01-492-8462	0XWR1	KTST10030A	REAMER,HAND..... BOI: 0 Per End Items	1
8	PAHZZA	4910-01-499-5069	1JEK9	70097-45549	ADAPTER,CYLINDER CO..... BOI: 0 Per End Items	1
9	PAHZZA	4910-00-728-8227	33287	J24460-01	TEST KIT,RADIATOR-R..... BOI: 0 Per End Items	1
10	PAHZZA	4910-01-499-5073	1JEK9	70097-10640	TESTER,DIESEL FUEL..... BOI: 0 Per End Items	1
11	PAHZZA	4940-01-499-5040	1JEK9	70097-10650	ADAPTER KIT,TEST..... BOI: 0 Per End Items	1
12	PAHZZA	4910-01-499-5067	1JEK9	07909-30202-E	ADAPTER,CYLINDER CO..... BOI: 0 Per End Items	1

End of Figure

SECTION IV

TM 9-6115-670-14&P

CROSS-REFERENCE INDEXES

NATIONAL STOCK NUMBER INDEX

STOCK NUMBER	FIG.	ITEM	STOCK NUMBER	FIG.	ITEM
4720-00-005-5008	BULK	4	5940-00-230-0515	C-28	3
5310-00-044-6477	C-2	23	5310-00-250-9477	C-2	123C
5310-00-052-3632	C-2	155	5325-00-276-6343	C-2	156
	C-27	37	5306-00-314-7352	BULK	12
5940-00-113-8179	C-11	4G	5310-00-400-5503	C-27	4
5940-00-113-8183	C-2	180	5305-00-417-4955	C-2	117
	C-2	186	5961-00-465-4405	C-2	131
	C-2	205	5930-00-539-7013	C-27	21
	C-21	9	5930-00-540-8311	C-27	18
5940-00-113-8184	C-11	4E		C-27	26A
	C-27	66	5305-00-543-2866	C-2	123G
	C-27	68	5305-00-543-4372	C-2	127
5940-00-113-9826	C-2	172	3120-00-554-6532	C-2	12
	C-2	175	5940-00-557-1629	C-27	28
	C-2	177		C-27	77
	C-2	182	4730-00-595-1721	C-5	4
	C-2	196		C-6	6
	C-2	203		C-17	2
	C-2	207		C-17	2
	C-2	220	5930-00-615-6731	C-27	25
	C-2	247	5342-00-684-9456	C-2	32
	C-22	6	5310-00-696-5173	C-2	136
5940-00-143-4771	C-2	191	4910-00-728-8227	C-29	9
	C-2	222	5320-00-754-0992	C-18	3
	C-2	249	5310-00-767-0445	C-2	25
	C-20	1	5305-00-782-9489	C-2	123F
	C-22	13	9320-00-787-6516	BULK	14
	C-23	7	5310-00-809-4058	C-4	16
	C-27	42	5340-00-818-6806	C-2	34
	C-27	45	9390-00-872-2219	BULK	8
	C-27	53	5310-00-903-8595	C-27	6
	C-27	53	5310-00-913-8881	C-2	71
	C-27	57		C-2	71
	C-27	57	5310-00-929-6395	C-27	8
	C-27	64	5320-00-932-1972	C-2	119B
	C-27	71	5310-00-933-8120	C-2	76A
	C-28	7	5310-00-933-8121	C-2	28
5940-00-143-4773	C-2	216		C-2	28
	C-2	226		C-27	3
	C-2	230	5310-00-934-9739	C-2	151
5940-00-143-4774	C-20	5	5310-00-934-9761	C-27	7
	C-28	1	5340-00-977-3992	C-2	104
5940-00-143-4777	C-21	6		C-6	5
5940-00-143-4780	C-20	1	5310-00-984-7042	C-2	30
	C-22	8		C-2	30
	C-28	2	5310-01-012-3595	C-2	14
5940-00-143-4794	C-2	209		C-2	14
5940-00-204-8990	C-21	2		C-2	76
5306-00-226-4829	C-2	22		C-18	8
4730-00-226-8874	C-6	7	4730-01-017-5119	C-5	1

SECTION IV

TM 9-6115-670-14&P

NATIONAL STOCK NUMBER INDEX

STOCK NUMBER	FIG.	ITEM	STOCK NUMBER	FIG.	ITEM
4730-01-017-5119	C-6	8	5950-01-247-3048	C-2	133
5940-01-027-4669	C-2	189	5930-01-262-7827	C-5	5
	C-2	193	5940-01-264-6657	C-2	198
	C-2	236		C-2	201
	C-2	255		C-2	218
	C-22	3		C-2	244
5940-01-052-7646	C-2	211		C-22	2
	C-2	214	5310-01-273-4535	C-18	4
	C-2	224	5935-01-291-2814	C-21	14
	C-2	228	5935-01-292-2336	C-21	13
	C-2	232	5935-01-308-8599	C-5	8
	C-2	234	5975-01-310-5011	C-6	3
	C-2	238		C-17	3
	C-2	241		C-19	1
	C-2	251		C-21	3
	C-2	253		C-23	3
	C-2	257	5306-01-320-7024	C-8	120
	C-20	2	5310-01-320-7038	C-8	21
	C-21	19	5310-01-320-7060	C-8	13
	C-22	10		C-11	23
	C-27	48	5305-01-320-7069	C-14	3
	C-27	51	5310-01-320-7100	C-8	22
	C-27	55		C-12	18
	C-27	55	5331-01-320-9557	C-8	10
	C-27	59	5331-01-320-9566	C-14	10
	C-27	59	5331-01-320-9567	C-14	4
	C-27	62	5315-01-321-2001	C-8	134
	C-27	62	5306-01-321-3371	C-8	112
	C-28	9		C-9	5
5940-01-082-3321	C-20	2	5306-01-321-3372	C-8	145
	C-21	7		C-10	2A
	C-22	1	5306-01-321-3375	C-8	149
	C-28	4		C-9	18
5905-01-087-1910	C-27	17	5325-01-321-3445	C-8	131
5935-01-095-4657	C-26	1	5310-01-321-3477	C-11	22
5935-01-110-1942	C-20	4	5306-01-321-7025	C-11	3
	C-28	5		C-12	25
5305-01-140-9118	C-2	126	5999-01-323-4929	C-6	4
2930-01-146-3634	C-2	88		C-17	4
5930-01-155-0768	C-27	26	5331-01-325-5809	C-14	2
4720-01-179-2479	BULK	3	5310-01-328-7657	C-2	41
5310-01-197-3108	C-2	91		C-2	41
5935-01-208-3507	C-2	154	5935-01-336-5396	C-21	11
5935-01-214-4163	C-17	5	5935-01-336-6409	C-23	1
	C-21	10	5935-01-338-3532	C-23	5
	C-23	6	6645-01-369-2478	C-27	12
5935-01-214-5259	C-17	5	4820-01-381-5079	C-2	90
	C-19	3	5945-01-382-8925	C-2	153
	C-21	22	5930-01-391-8105	C-11	13
5935-01-226-8367	C-22	7	5306-01-393-4861	C-8	40

SECTION IV

TM 9-6115-670-14&P

NATIONAL STOCK NUMBER INDEX

STOCK NUMBER	FIG.	ITEM	STOCK NUMBER	FIG.	ITEM
5306-01-393-4863	C-10	12	5330-01-478-5112	C-9	9
5310-01-393-6781	C-8	55A	5930-01-478-5114	C-27	19
5999-01-406-4110	C-17	4	5331-01-478-5115	C-9	27
	C-21	5	5310-01-478-5116	C-11	17
5310-01-418-2334	C-2	38	5310-01-478-5120	C-8	14
5999-01-422-9740	C-21	12	5330-01-478-5144	C-9	16
4730-01-434-3875	C-9	6	5330-01-478-5146	C-10	5
5306-01-435-8407	C-8	88C	5330-01-478-5153	C-8	72
4730-01-436-1167	C-8	9	5330-01-478-5156	C-8	152
	C-8	88G	6625-01-478-5158	C-27	15
2990-01-436-1329	C-10	10	5330-01-478-5159	C-8	151
5330-01-437-1059	C-10	3	5330-01-478-5161	C-8	106
5365-01-437-1064	C-12	21	6625-01-478-5163	C-27	14
5365-01-437-1065	C-12	20	5330-01-478-5164	C-8	63
2990-01-438-8808	C-9	7	6625-01-478-5168	C-27	24
2590-01-438-8872	C-12	7	5330-01-478-5169	C-8	61
2910-01-439-4915	C-12	15	5310-01-478-5170	C-9	13
2815-01-439-4961	C-9	3	5310-01-478-5171	C-8	23
5310-01-440-6749	C-11	15	6625-01-478-5172	C-27	13
6685-01-442-2395	C-11	5	5310-01-478-5173	C-12	17
2930-01-445-6361	C-10	16	5310-01-478-5177	C-8	8
5330-01-446-2136	C-2	56	5310-01-478-5178	C-8	90
2815-01-456-6955	C-7	1	5310-01-478-5181	C-8	103
5310-01-467-6832	C-4	15	5310-01-478-5186	C-8	104
4730-01-470-1567	C-2	46	5310-01-478-5187	C-8	59
	C-2	46	5310-01-478-5208	C-2	82
4730-01-470-1626	C-12	3	5935-01-478-5219	C-21	1
5310-01-470-1981	C-2	3	5940-01-478-5485	C-2	143
4730-01-470-2409	C-10	2	5310-01-478-5620	C-2	40
4720-01-470-6230	BULK	5		C-2	40
5310-01-471-0633	C-2	2		C-7	8
	C-2	2		C-7	8
5310-01-471-0640	C-2	79	5310-01-478-5622	C-2	36
	C-2	79		C-2	36
	C-18	4	2990-01-478-5686	C-2	54
5307-01-477-2256	C-12	22	2990-01-478-5696	C-8	99
5310-01-478-4828	C-2	93	2990-01-478-5699	C-2	118
5330-01-478-4843	C-8	34	5310-01-478-5700	C-2	150
5330-01-478-4849	C-13	4	5310-01-478-5703	C-2	125
5330-01-478-4851	C-13	2		C-4	26
5331-01-478-4863	C-8	108	5310-01-478-5719	C-2	18
5331-01-478-4864	C-8	126	2990-01-478-5724	C-2	62
5331-01-478-4867	C-8	73		C-27	34
5331-01-478-4871	C-9	35	5310-01-478-5780	C-2	24
5330-01-478-4887	C-8	82	5310-01-478-5935	C-2	60
5330-01-478-4911	C-8	7		C-7	3
	C-12	16	5331-01-478-5997	C-8	168
5930-01-478-5110	C-27	20	5331-01-478-5999	C-8	95
5925-01-478-5111	C-2	132	5330-01-478-6002	C-8	31

SECTION IV

TM 9-6115-670-14&P

NATIONAL STOCK NUMBER INDEX

STOCK NUMBER	FIG.	ITEM	STOCK NUMBER	FIG.	ITEM
5330-01-478-6004	C-8	148	2915-01-478-6910	C-2	112
5940-01-478-6050	C-2	188	5325-01-478-6921	C-8	117
	C-2	259	5315-01-478-6939	C-8	111
	C-20	6	6210-01-478-6973	C-27	27
	C-22	5	4730-01-478-7119	C-10	18
	C-22	11	4730-01-478-7123	C-9	19
5940-01-478-6072	C-22	4	4730-01-478-7130	C-9	29
5935-01-478-6077	C-21	4		C-10	8
5940-01-478-6081	C-21	8	4720-01-478-7182	C-10	9
3110-01-478-6106	C-8	125	4720-01-478-7185	C-10	19
3120-01-478-6107	C-8	142	6110-01-478-7200	C-1	1
3120-01-478-6109	C-8	142	4820-01-478-7226	C-8	75
3120-01-478-6111	C-8	142	5340-01-478-7430	C-2	107
3120-01-478-6113	C-8	144	5340-01-478-7436	C-8	42
3120-01-478-6114	C-8	144	2815-01-478-7450	C-8	33
3120-01-478-6117	C-8	144	2815-01-478-7465	C-8	32
3120-01-478-6120	C-8	143	2815-01-478-7478	C-8	76
3120-01-478-6123	C-8	143	2815-01-478-7480	C-8	19
3120-01-478-6124	C-8	143	5340-01-478-7486	C-8	105
3120-01-478-6125	C-8	135	2815-01-478-7487	C-8	123
	C-8	139	2815-01-478-7489	C-8	122
3120-01-478-6126	C-8	135	2815-01-478-7493	C-8	133
	C-8	139	2920-01-478-7511	C-11	18
3120-01-478-6127	C-8	139	2815-01-478-7538	C-8	44
3120-01-478-6128	C-8	135	5340-01-478-7608	C-2	67
3120-01-478-6129	C-8	135	5342-01-478-7900	C-2	75
3120-01-478-6131	C-8	135	5342-01-478-7932	C-2	113
3120-01-478-6132	C-16	3		C-2	135
3120-01-478-6135	C-16	3	5905-01-478-8109	C-27	23
3120-01-478-6137	C-16	3	5310-01-478-8451	C-2	139
3120-01-478-6138	C-16	1	5355-01-478-8487	C-27	16
5310-01-478-6340	C-2	19	2910-01-478-8822	C-12	24
	C-2	19	5306-01-478-8880	C-2	55
5310-01-478-6341	C-2	116	5306-01-478-8895	C-2	37
	C-27	33	5306-01-478-8896	C-2	48
5310-01-478-6342	C-2	141	5306-01-478-8897	C-2	59
5310-01-478-6344	C-2	23	5310-01-478-9244	C-2	114
	C-2	72B		C-27	35
	C-27	9	5310-01-478-9268	C-2	157
5310-01-478-6346	C-27	2	2940-01-478-9487	C-14	6
5330-01-478-6354	C-9	10	4820-01-479-0226	C-8	167
5330-01-478-6366	C-12	27	5945-01-479-0301	C-2	167
5330-01-478-6369	C-8	5	5306-01-479-0327	C-9	14
6110-01-478-6439	C-2	158	5306-01-479-0332	C-10	24
2990-01-478-6488	C-2	65	5306-01-479-0335	C-10	7
2990-01-478-6489	C-2	68	5306-01-479-0338	C-11	20
4720-01-478-6491	C-10	1	5306-01-479-0350	C-12	29
2990-01-478-6492	C-11	6	5306-01-479-0352	C-7	9
4720-01-478-6494	C-10	23	5306-01-479-0355	C-8	77
5310-01-478-6511	C-2	137		C-8	88A

SECTION IV

TM 9-6115-670-14&P

NATIONAL STOCK NUMBER INDEX

STOCK NUMBER	FIG.	ITEM	STOCK NUMBER	FIG.	ITEM
5306-01-479-0359	C-8	136	5305-01-479-1846	C-27	31
5306-01-479-0360	C-8	138	5306-01-479-3983	C-2	74
5306-01-479-0361	C-16	2	5120-01-479-5832	C-29	1
5306-01-479-0363	C-8	101	5305-01-480-1127	C-13	1
5306-01-479-0365	C-8	107	5340-01-480-1364	C-6	2
5306-01-479-0366	C-8	102	9390-01-480-2555	BULK	7
5306-01-479-0367	C-8	80	5305-01-480-4686	C-2	109
5306-01-479-0369	C-8	54	5305-01-480-4690	C-2	35
5331-01-479-0530	C-24	14		C-2	35
5330-01-479-0531	BULK	15		C-2	58
5305-01-479-0551	C-27	32	6150-01-482-4325	C-1	2
6150-01-479-0594	C-2	162	6115-01-484-6250	C-2	164
2815-01-479-0604	C-8	153	2990-01-485-7699	C-2	64
2815-01-479-0672	C-8	132	5306-01-485-8353	C-8	147
3020-01-479-0690	C-8	128	5307-01-485-8363	C-8	55
2815-01-479-0929	C-8	127	5307-01-485-8384	C-8	83
5305-01-479-1061	C-3	2	5307-01-485-8389	C-8	39
5305-01-479-1176	C-2	123A	5365-01-485-9240	C-8	109
	C-4	14	5365-01-485-9244	C-11	12
5305-01-479-1180	C-2	101	3130-01-485-9253	C-8	114
	C-2	101	6110-01-485-9791	C-2	130
	C-2	117A	6685-01-486-0361	C-29	5
5305-01-479-1181	C-2	81	5307-01-486-0464	C-2	144
5305-01-479-1186	C-2	110	6685-01-486-1376	C-27	22
5305-01-479-1189	C-2	94	5315-01-486-1942	C-9	11
	C-2	94	5961-01-486-1969	C-25	2
5305-01-479-1190	C-2	27	5961-01-486-1973	C-25	4
5305-01-479-1193	C-2	29	2910-01-486-2144	C-2	21
5305-01-479-1196	C-2	1	4730-01-486-3468	C-12	30
	C-2	1	4730-01-486-3490	C-13	3
	C-4	18	5360-01-486-3739	C-8	74
5305-01-479-1197	C-2	112A	5360-01-486-3742	C-8	97
5305-01-479-1198	C-2	5	5325-01-486-3846	C-8	115
	C-2	11	5360-01-486-3906	C-8	98
	C-2	80	3110-01-486-4864	C-24	15
5305-01-479-1199	C-2	17	5120-01-486-5065	C-29	3
5305-01-479-1201	C-2	87	5360-01-486-5154	C-8	24
5305-01-479-1206	C-2	80	5360-01-486-5180	C-8	91
5305-01-479-1212	C-2	161	5340-01-486-5978	C-2	146
5305-01-479-1214	C-2	112	3020-01-486-7671	C-9	12
4720-01-479-1362	C-2	111	3020-01-486-7673	C-8	119
2920-01-479-1725	C-11	19	3030-01-490-6137	C-8	81
2930-01-479-1801	C-2	89	5110-01-492-8462	C-29	7
5305-01-479-1839	C-2	163	6110-01-494-3003	C-1	1
5305-01-479-1841	C-2	149	2915-01-494-3004	C-12	19
5305-01-479-1842	C-2	148	2935-01-494-6330	C-2	89
5305-01-479-1843	C-27	10	2935-01-494-6331	C-2	89
5305-01-479-1844	C-2	147	2815-01-494-7123	C-7	1
5305-01-479-1845	C-27	11	2815-01-494-7963	C-8	37
5305-01-479-1846	C-11	4A	2310-14-497-4269	C-11	21

SECTION IV

TM 9-6115-670-14&P

NATIONAL STOCK NUMBER INDEX

STOCK NUMBER	FIG.	ITEM	STOCK NUMBER	FIG.	ITEM
5305-14-514-1569	C-8	64			
5305-14-514-1572	C-8	92			
5305-14-514-1576	C-8	52			
2990-21-921-2413	C-2	57			
5340-99-235-4309	C-8	29			
2815-99-457-4475	C-9	15			
2815-99-500-2175	C-8	129			
2815-99-553-2023	C-8	129			
2910-99-595-0571	C-8	116			
2815-99-610-4361	C-8	28			
2940-99-980-8342	C-8	78			

SECTION IV

TM 9-6115-670-14&P

PART NUMBER INDEX

CAGEC	PART NUMBER	STOCK NUMBER	FIG.	ITEM
56501	A-250	5940-01-027-4669	C-2	189
			C-2	193
			C-2	236
			C-2	255
			C-22	3
58536	AA52406-3-SB	5340-01-478-7608	C-2	67
65149	AKKH175		C-2	7
97403	ASSEMBLY-1		C-24	25
81346	ASTMA582	5306-00-314-7352	BULK	12
81346	ASTMA582-1INCH		C-2	13
98410	BB-837-06	5940-00-113-8179	C-11	4G
98410	BB-837-10	5940-00-143-4780	C-20	1
			C-22	8
			C-28	2
05624	BYRF2516		C-2	5
80204	B1821BH031C125N	5306-00-226-4829	C-2	22
80204	B1821BH038C075N	5305-00-543-4372	C-2	127
80204	B1821BH038C088N	5305-01-140-9118	C-2	126
80204	B1821BH038C200N	5305-00-782-9489	C-2	123F
80204	B1821BH038C250N	5305-00-543-2866	C-2	123G
81346	B1821BH38C100N		C-4	11
80204	B18212HRCZ080	5310-01-478-5620	C-2	40
			C-2	40
			C-7	8
			C-7	8
80204	B18212HRCZ100	5310-01-478-5622	C-2	36
			C-2	36
80204	B1822BS080R	5310-01-418-2334	C-2	38
80204	B18235B06010N	5306-01-478-8897	C-2	59
80204	B18235B06050N		C-7	2
80204	B18235B08016N	5306-01-478-8896	C-2	48
80204	B18235B08020-1		C-7	7
			C-7	7
80205	B18235B08020N	5306-01-478-8880	C-2	55
80205	B18235B08070N	5306-01-478-8895	C-2	37
80204	B18241B080	5310-01-328-7657	C-2	41
			C-2	41
81860	C2060T6	5340-00-818-6806	C-2	34
78553	C7931-1024-3B	5340-00-977-3992	C-2	104
78553	C7931-1032-3B	5310-00-903-8595	C-27	6
78553	C7941-1024-3B	5310-01-197-3108	C-2	91
D8286	DIN912-M10X35X1.5X35-8.8		C-2	43B
			C-4	3
05624	DYNK218-2		C-2	6
05624	DYNK31-006		C-2	9
05624	DYNT17200		C-19	4
05624	DYRF29		C-2	8
0X832	FSP3X9	2990-21-921-2413	C-2	57
73134	HF3G	3120-00-554-6532	C-2	12
19008	ISO8676-M10X1.25X20-8.8	5305-01-480-4686	C-2	109

SECTION IV

TM 9-6115-670-14&P

PART NUMBER INDEX

CAGEC	PART NUMBER	STOCK NUMBER	FIG.	ITEM
19008	ISO8676-M10X1.25 X25-8.8	5305-01-480-4690	C-2	35
			C-2	35
			C-2	58
33287	J24460-01	4910-00-728-8227	C-29	9
OXWR1	KTST10030A	5110-01-492-8462	C-29	7
OXWR1	KTST10060-E		C-29	12
OXWR1	KTST10060-G		C-29	8
OXWR1	KTST20010		C-29	10
OXWR1	KTST20020		C-29	11
98897	LS12906-87	5305-00-417-4955	C-2	117
10988	L124720	5935-01-291-2814	C-21	14
96906	MS-25036-103	5940-00-143-4771	C-2	191
			C-2	222
			C-2	249
			C-20	1
			C-22	13
			C-27	42
			C-27	45
			C-27	53
			C-27	53
			C-27	57
			C-27	57
			C-27	64
			C-27	71
			C-28	7
80205	MS15795-848	5310-01-273-4535	C-18	4
81343	MS25036-103	5940-00-143-4771	C-23	7
81343	MS25036-112	5940-00-143-4794	C-2	209
96906	MS25036-113	5940-00-113-8183	C-2	180
			C-2	186
			C-2	205
			C-21	9
81343	MS25036-157	5940-00-143-4777	C-21	6
96906	MS25224-1	5930-00-615-6731	C-27	25
96906	MS27183-10	5310-00-809-4058	C-4	16
96906	MS27735-23	5930-00-540-8311	C-27	18
			C-27	26A
96906	MS3406DJ24A28S	5935-01-095-4657	C-26	1
96906	MS3408DJ28D-11S	5935-01-478-5219	C-21	1
96906	MS3452W24-28P	5935-01-110-1942	C-20	4
			C-28	5
96906	MS3452W28-11P	5935-01-226-8367	C-22	7
96906	MS35333-110		C-2	140
80205	MS35338-136	5310-00-929-6395	C-27	8
96906	MS35338-138	5310-00-933-8120	C-2	76A
96906	MS35338-141	5310-00-984-7042	C-2	30
			C-2	30
96906	MS35338-43		C-2	15
96906	MS35489-23	5325-00-276-6343	C-2	156
96906	MS35649-242	5310-00-934-9739	C-2	151

SECTION IV

TM 9-6115-670-14&P

PART NUMBER INDEX

CAGEC	PART NUMBER	STOCK NUMBER	FIG.	ITEM
96906	MS35649-264	5310-00-934-9761	C-27	7
96906	MS35650-3254	5310-00-400-5503	C-27	4
96906	MS51412-25	5310-00-044-6477	C-2	23
96906	MS51971-2	5310-00-767-0445	C-2	25
81349	M3AA414BC1	9320-00-787-6516	BULK	14
81349	M5423/02-01	5930-00-539-7013	C-27	21
05624	N1-1		C-2	4
18876	P12934-010-01	5905-01-087-1910	C-27	17
97403	SYSTEM-1		C-8	4
97403	SYSTEM-2		C-8	2
97403	SYSTEM-3		C-8	3
97403	SYSTEM-4		C-8	1
14726	S05300F	5940-01-052-7646	C-2	211
			C-2	214
			C-2	224
			C-2	228
			C-2	232
			C-2	234
			C-2	238
			C-2	241
			C-2	251
			C-2	253
			C-2	257
			C-20	2
			C-21	19
			C-22	10
			C-23	8
			C-27	48
			C-27	51
			C-27	55
			C-27	55
			C-27	59
			C-27	59
			C-27	62
			C-27	62
			C-28	9
77342	VF4-15H11-S05	5945-01-382-8925	C-2	153
05047	W212NAA0060NN041NNCG1	5310-01-478-5935	C-2	60
			C-7	3
70485	X-1054	9390-00-872-2219	BULK	8
4X687	001-08104		C-25	5
4X687	003-25158		C-24	3
4X687	005-04076		C-24	10
31013	01023-50610	5306-01-393-4861	C-8	40
S4532	01023-50612	5306-01-321-3371	C-8	112
			C-9	5
S4532	01023-50614	5306-01-320-7024	C-8	120
S4532	01023-50616	5306-01-321-7025	C-10	6
			C-11	3
			C-12	25

SECTION IV

TM 9-6115-670-14&P

PART NUMBER INDEX

CAGEC	PART NUMBER	STOCK NUMBER	FIG.	ITEM
0XWR1	01023-50618	5305-14-514-1569	C-8	64
S4532	01023-50620	5306-01-321-3375	C-8	149
			C-9	18
0XWR1	01023-50622	5306-01-321-3372	C-8	145
			C-10	2A
0XWR1	01023-50635	5306-01-479-0363	C-8	101
0XWR1	01023-50645		C-8	65
0XWR1	01023-50660		C-8	88F
S8029	01023-50675	2940-99-980-8342	C-8	78
0XWR1	01023-50680	5306-01-435-8407	C-8	88C
0XWR1	01023-60650		C-8	82A
			C-8	88E
0XWR1	01023-60670		C-8	88
0XWR1	01053-50618	5305-14-514-1572	C-8	92
0XWR1	01123-50825		C-11	1
0XWR1	01123-50828	5305-14-514-1576	C-8	52
0XWR1	01123-60814		C-9	4
0XWR1	01123-60816		C-8	35
			C-8	147B
0XWR1	01153-50828	5306-01-479-0338	C-11	20
0XWR1	01173-51090		C-11	14
0XWR1	01203-50638	5306-01-479-0332	C-10	24
0XWR1	01311-10620	5306-01-479-0350	C-12	29
0XWR1	01311-10828	5306-01-479-0369	C-8	54
4X687	015-41607		C-24	5
0XWR1	01513-50828	5307-01-485-8363	C-8	55
0XWR1	01513-60820		C-8	57
4X687	016-40716		C-24	8
4X687	016-40717		C-24	28
4X687	016-40817		C-24	19
31013	01754-50610	5306-01-393-4863	C-10	12
0XWR1	01759-50616		C-8	60
0XWR1	02056-50060	5310-01-320-7038	C-8	21
0XWR1	02114-50080	5310-01-320-7060	C-8	13
			C-11	23
31013	02156-50080	5310-01-393-6781	C-8	55A
0XWR1	02176-50100		C-11	9
4X687	024-70618		C-24	31
0XWR1	02751-50060		C-10	22
0XWR1	02756-50060	5310-01-478-5187	C-8	59
0XWR1	02761-50040	5310-01-440-6749	C-11	15
0XWR1	02783-50100	5310-01-478-5170	C-9	13
4X687	028-31506		C-24	22
			C-25	6
4X687	028-31507		C-24	6
4X687	028-31508		C-24	20
4X687	029-63002		C-24	9
			C-25	7
4X687	029-63006		C-24	23
4X687	030-02813	5330-01-479-0531	BULK	15
4X687	030-02813-1METER		C-24	4

SECTION IV

TM 9-6115-670-14&P

PART NUMBER INDEX

CAGEC	PART NUMBER	STOCK NUMBER	FIG.	ITEM
0XWR1	04011-50100		C-11	11
0XWR1	04012-50060	5310-01-478-5171	C-8	23
0XWR1	04013-60040	5310-01-478-5116	C-11	17
0XWR1	04013-60080	5310-01-478-5120	C-8	14
0XWR1	04013-60100		C-11	13A
0XWR1	04015-60080		C-11	2
0XWR1	04512-60060	5310-01-320-7100	C-8	22
			C-12	18
0XWR1	04512-60080		C-8	53
		5310-01-321-3477	C-11	22
0XWR1	04512-60100		C-11	10
0XWR1	04612-00170	5325-01-486-3846	C-8	115
0XWR1	04724-00140		C-8	70
31013	04810-00060	5331-01-325-5809	C-14	2
S4532	04811-00390	5331-01-320-9567	C-14	4
0XWR1	04811-06130	5331-01-478-4867	C-8	73
0XWR1	04811-06230	5331-01-478-4865	C-8	85
0XWR1	04811-10070	5331-01-478-5999	C-8	95
0XWR1	04811-10160	5331-01-478-4863	C-8	108
0XWR1	04811-16220	5331-01-478-4864	C-8	126
0XWR1	04811-50300	5331-01-320-9557	C-8	10
0XWR1	04814-50600	5331-01-478-4871	C-9	35
0XWR1	05012-00508		C-8	155
0XWR1	05012-00814		C-8	160
4X687	051-01058	3110-01-486-4864	C-24	15
4X687	051-21792	5331-01-479-0530	C-24	14
0XWR1	05411-00318	5315-01-478-6939	C-8	111
0XWR1	05411-00420		C-8	26
0XWR1	05712-00408	5315-01-486-1942	C-9	11
0XWR1	05712-00515	5315-01-321-2001	C-8	134
4X687	073-08063		C-25	8
4X687	073-50032	5961-01-486-1969	C-25	2
4X687	073-50033	5961-01-486-1973	C-25	4
0XWR1	07715-03211	4820-01-478-7226	C-8	75
0XWR1	07909-31661	5120-01-479-5832	C-29	1
0XWR1	07909-33102		C-29	2
0XWR1	07916-09032	5120-01-486-5065	C-29	3
0XWR1	07916-32011		C-29	4
0XWR1	07916-32032	6685-01-486-0361	C-29	5
0XWR1	07916-34041		C-29	6
0XWR1	08103-06203	3130-01-485-9253	C-8	114
0XWR1	09318-88180		C-9	19A
0XWR1	09318-88200	4730-01-478-7123	C-9	19
0XWR1	09318-89030	4730-01-478-7119	C-10	18
72853	10230	2930-01-146-3634	C-2	88
29381	1122001A		C-2	17
29381	1131001A		C-4	14
29381	1131002A		C-2	1
29381	1132002A		C-2	22
29381	1132006A		C-2	72
29381	1133003A		C-2	94

SECTION IV

TM 9-6115-670-14&P

PART NUMBER INDEX

CAGEC	PART NUMBER	STOCK NUMBER	FIG.	ITEM
0XWR1	11420-13150	5330-01-478-6002	C-8	31
29381	1142001A		C-2	59
29381	1142004A		C-7	9
29381	1142007A		C-7	2
29381	1143002A		C-2	55
			C-2	126
			C-7	7
29381	1143004A		C-2	37
29381	1143006A		C-2	122A
77060	1201 0717	5935-01-336-6409	C-23	1
77060	1201 0974	5935-01-336-5396	C-21	11
64678	1201 0996	5935-01-338-3532	C-23	5
22785	12010973	5935-01-214-4163	C-17	5
			C-21	10
			C-23	6
77060	12015323	5975-01-310-5011	C-6	3
			C-17	3
			C-19	1
			C-21	3
			C-23	3
77060	12015792	5935-01-214-5259	C-17	5
			C-19	3
			C-21	22
77060	12015793	5935-01-292-2336	C-21	13
77060	1208 9188	5999-01-323-4929	C-6	4
			C-17	4
29381	1211009A		C-2	124B
77060	12124582	5999-01-406-4110	C-17	4
			C-21	5
4X687	122-NR01S571221		C-24	17
4X687	122-N6000		C-24	1
29381	1224001A		C-2	144A
29381	1224011A		C-2	114A
29381	1224012A		C-2	50
			C-2	112H
29381	1224015A		C-2	155
29381	1224017A		C-2	151
			C-2	157
			C-27	36A
29381	1224201A		C-2	104
			C-2	121A
			C-18	6
			C-27	6
19207	12325823	4730-00-226-8874	C-6	7
19207	12420936	5999-01-422-9740	C-21	12
93061	125HBL-5-4	4730-00-595-1721	C-17	2
			C-17	2
4X687	130-1379		C-24	13
4X687	130-1384		C-24	16
4X687	130-1413		C-25	1
4X687	130-1414		C-25	3

SECTION IV

TM 9-6115-670-14&P

PART NUMBER INDEX

CAGEC	PART NUMBER	STOCK NUMBER	FIG.	ITEM
4X687	130-20123		C-24	7
4X687	130-20602		C-25	9
4X687	130-20661		C-24	11
4X687	130-20667		C-24	12
4X687	130-20761		C-24	29
4X687	130-20799		C-24	2
4X687	130-20800		C-24	21
4X687	130-20930		C-24	18
4X687	130-21017		C-24	30
4X687	130-21020		C-24	27
4X687	130-21297		C-24	24
4X687	130-21325		C-24	26
29381	1313004A		C-2	79
			C-2	103
29381	1313006A		C-2	2
29381	1313008A		C-2	19
29381	1314004A		C-2	38
29381	1315001A		C-27	33
29381	1321008A		C-2	124A
97403	13214E3789-2	5320-00-932-1972	C-2	119B
97403	13217E3854-1	5940-00-557-1629	C-27	28
			C-27	77
97403	13217E3854-4	5940-00-113-8184	C-11	4E
			C-27	66
			C-27	68
97403	13217E3854-5	5940-00-143-4773	C-2	216
			C-2	226
			C-2	230
97403	13217E7108-17	4730-01-017-5119	C-5	1
			C-6	8
97403	13217E7108-5	4730-00-595-1721	C-5	4
			C-6	6
97403	13218E0320-129	5310-01-478-9244	C-2	114
			C-27	35
97403	13218E0320-248	5310-01-478-9268	C-2	157
97403	13218E0320-291	5310-00-250-9477	C-2	123C
97403	13218E0320-293	5310-00-913-8881	C-2	71
			C-2	71
97403	13218E0320-333	5310-01-478-8451	C-2	139
97403	13218E0320-89		C-2	76
97403	13218E0493-1287PIIC	5305-01-479-1846	C-11	4A
			C-27	31
97403	13218E0493-1289PIIC	5305-01-479-1845	C-27	11
97403	13218E0493-1810PIIC		C-2	48
97403	13218E0493-2765		C-4	21
97403	13218E0493-2770PIIC	5305-01-479-1843	C-27	10
97403	13218E0493-289PIIC	5305-01-479-1839	C-2	163

SECTION IV

TM 9-6115-670-14&P

PART NUMBER INDEX

CAGEC	PART NUMBER	STOCK NUMBER	FIG.	ITEM
97403	13218E0493-345PIIC	5305-01-479-1841	C-2	149
97403	13218E0493-349PI IC	5305-01-479-1844	C-2	147
97403	13218E0493-350PIIC		C-2	147
97403	13218E0493-354PIIC	5305-01-479-1842	C-2	148
97403	13226E0107-12	5940-00-143-4774	C-20	5
			C-28	1
97403	13226E0107-14	5940-00-230-0515	C-28	3
97403	13226E0107-18	5940-00-204-8990	C-21	2
97403	13226E0107-23	5940-00-113-9826	C-2	172
			C-2	175
			C-2	177
			C-2	182
			C-2	196
			C-2	203
			C-2	207
			C-2	220
			C-2	247
			C-22	6
97403	13230E6219		C-2	119A
97403	13230E6220	6110-01-478-7200	C-1	1
97403	13230E6221		C-27	1
97403	13230E6222	6625-01-478-5158	C-27	15
97403	13230E6223	6625-01-478-5163	C-27	14
97403	13230E6224	6625-01-478-5172	C-27	13
97403	13230E6225	6625-01-478-5168	C-27	24
97403	13230E6227		C-27	29
97403	13230E6229	6210-01-478-6973	C-27	27
97403	13230E6231-4		C-2	155A
97403	13230E6232-1		C-27	63
97403	13230E6232-10		C-27	38D
97403	13230E6232-11Z		C-27	75
97403	13230E6232-12		C-27	38C
97403	13230E6232-13		C-27	38B
97403	13230E6232-14		C-27	38
97403	13230E6232-15		C-2	192
97403	13230E6232-16		C-2	168
97403	13230E6232-17		C-2	176
97403	13230E6232-18		C-2	199
97403	13230E6232-19		C-2	170
97403	13230E6232-2		C-27	67
97403	13230E6232-20		C-2	173
97403	13230E6232-21		C-2	195
97403	13230E6232-22		C-2	202
97403	13230E6232-23		C-2	206
97403	13230E6232-24		C-2	217
97403	13230E6232-25		C-2	252
97403	13230E6232-26		C-2	233

SECTION IV

TM 9-6115-670-14&P

PART NUMBER INDEX

CAGEC	PART NUMBER	STOCK NUMBER	FIG.	ITEM
97403	13230E6232-27		C-2	237
97403	13230E6232-28		C-2	210
97403	13230E6232-29		C-2	213
97403	13230E6232-3		C-27	52
97403	13230E6232-30		C-2	225
97403	13230E6232-31		C-2	229
97403	13230E6232-32		C-2	248
97403	13230E6232-33		C-2	221
97403	13230E6232-34		C-2	168A
97403	13230E6232-35		C-2	168B
97403	13230E6232-36		C-2	168C
97403	13230E6232-37ZZ		C-2	240
97403	13230E6232-38		C-11	4D
97403	13230E6232-4		C-27	56
97403	13230E6232-5		C-27	60
97403	13230E6232-6		C-27	46
97403	13230E6232-7		C-27	40
97403	13230E6232-8		C-27	38E
97403	13230E6232-9		C-27	38A
97403	13230E6233	5905-01-478-8109	C-27	23
97403	13230E6235		C-27	30
97403	13230E6236-2	5940-01-478-6050	C-2	188
			C-2	259
			C-20	6
			C-22	5
			C-22	11
97403	13230E6236-3	5940-01-478-6072	C-22	4
97403	13230E6237-4	5940-01-478-6081	C-21	8
97403	13230E6240-1		C-5	7
			C-19	2
97403	13230E6241-3		C-23	2
97403	13230E6242-6		C-5	6
97403	13230E6244	6685-01-486-1376	C-27	22
97403	13230E6245-4		C-27	5
97403	13230E6248		C-2	160
97403	13230E6249		C-2	159
97403	13230E6250		C-23	4
97403	13230E6251	2990-01-478-5699	C-2	118
97403	13230E6252	6110-01-478-6439	C-2	158
97403	13230E6253	5925-01-478-5111	C-2	132
97403	13230E6254	6110-01-485-9791	C-2	130
97403	13230E6255	5930-01-478-5110	C-27	20
97403	13230E6256	5940-01-478-5485	C-2	143
97403	13230E6258	6150-01-479-0594	C-2	162
97403	13230E6259		C-2	187
97403	13230E6260		C-2	122
97403	13230E6261		C-2	165
97403	13230E6262		C-2	134
97403	13230E6263	5340-01-486-5978	C-2	146
97403	13230E6264		C-2	166
97403	13230E6265		C-2	152

SECTION IV

TM 9-6115-670-14&P

PART NUMBER INDEX

CAGEC	PART NUMBER	STOCK NUMBER	FIG.	ITEM
97403	13230E6266		C-2	145
97403	13230E6267		C-2	138
97403	13230E6268		C-2	119
97403	13230E6269		C-2	121
97403	13230E6270		C-2	128
97403	13230E6271		C-2	112F
97403	13230E6272		C-2	120
97403	13230E6273		C-2	112G
97403	13230E6274-1	5342-01-478-7932	C-2	113
			C-2	135
97403	13230E6275		C-2	142
97403	13230E6276	5307-01-486-0464	C-2	144
97403	13230E6278	5930-01-478-5114	C-27	19
97403	13230E6279	5945-01-479-0301	C-2	167
97403	13230E6280	2910-01-486-2144	C-2	21
97403	13230E6282	2930-01-479-1801	C-2	89
97403	13230E6283		C-18	1
97403	13230E6286		C-2	106
97403	13230E6287		C-2	85
97403	13230E6288-1		C-18	2
97403	13230E6288-2		C-18	5
97403	13230E6288-3		C-18	5
97403	13230E6289		C-2	84
97403	13230E6290		C-2	86
97403	13230E6291		C-2	105
97403	13230E6292-1-46I		C-2	83
	NCH			
97403	13230E6292-2	9390-01-480-2555	BULK	7
97403	13230E6292-2-11I		C-3	4
	NCH			
97403	13230E6293		C-3	3
97403	13230E6294	5310-01-478-5208	C-2	82
97403	13230E6295		C-2	112C
97403	13230E6297		C-2	20
97403	13230E6298		C-5	3
97403	13230E6299		C-2	100
97403	13230E6300		C-1	3
97403	13230E6301		C-3	1
97403	13230E6302	6115-01-484-6250	C-2	164
97403	13230E6303	2815-01-456-6955	C-7	1
97403	13230E6305		C-17	1
97403	13230E6306	5935-01-478-6077	C-21	4
97403	13230E6307		C-7	4
97403	13230E6308	6150-01-482-4325	C-1	2
97403	13230E6310	2990-01-478-6489	C-2	68
97403	13230E6312		C-2	129
97403	13230E6314		C-2	39
97403	13230E6315		C-2	33
97403	13230E6316		C-2	66
97403	13230E6317	2990-01-485-7699	C-2	64
97403	13230E6318		C-2	31

SECTION IV

TM 9-6115-670-14&P

PART NUMBER INDEX

CAGEC	PART NUMBER	STOCK NUMBER	FIG.	ITEM
97403	13230E6320	2990-01-478-6492	C-11	6
97403	13230E6322		C-7	6
97403	13230E6323		C-7	5
97403	13230E6324		C-2	42
97403	13230E6326	5310-01-478-4828	C-2	93
97403	13230E6327	2990-01-478-6488	C-2	65
97403	13230E6328		C-2	44
97403	13230E6329		C-2	45
97403	13230E6330	4720-01-478-6491	C-10	1
97403	13230E6331	4720-01-478-6494	C-10	23
97403	13230E6332		C-2	123
97403	13230E6333		C-2	43
97403	13230E6334		C-2	49
97403	13230E6335		C-2	70
97403	13230E6336		C-11	8
97403	13230E6337		C-2	16
97403	13230E6339	2920-01-479-1725	C-11	19
97403	13230E6340		C-2	26
97403	13230E6342		C-2	108
97403	13230E6343	4720-01-479-1362	C-2	111
97403	13230E6344	2915-01-478-6910	C-2	112
97403	13230E6345		C-2	78
97403	13230E6346		C-2	77
97403	13230E6347	5306-01-479-3983	C-2	74
97403	13230E6644-1	5342-01-478-7900	C-2	75
97403	13230E6645		C-2	73
97403	13230E6646		C-4	13
97403	13230E6647		C-4	17
97403	13230E6648		C-4	1
97403	13230E6649		C-2	44A
97403	13230E6650-2		C-26	1
97403	13230E6653-4		BULK	16
97403	13230E6653-4-11 INCH		C-27	39C
97403	13230E6653-4-11INCH		C-27	39
			C-27	39A
			C-27	39B
97403	13230E6653-4-14INCH		C-2	169
97403	13230E6653-4-15.5INCH		C-27	76
97403	13230E6653-4-17INCH		C-2	212
97403	13230E6653-4-18.5INCH		C-2	239
97403	13230E6653-4-18INCH		C-27	50
97403	13230E6653-4-2INCH		C-2	262
			C-27	39E

SECTION IV

TM 9-6115-670-14&P

PART NUMBER INDEX

CAGEC	PART NUMBER	STOCK NUMBER	FIG.	ITEM
97403	13230E6653-4-24INCH		C-2	190
			C-2	215
97403	13230E6653-4-26.5INCH		C-2	250
97403	13230E6653-4-26.62INCH		C-2	235
97403	13230E6653-4-28INCH		C-2	254
97403	13230E6653-4-3INCH		C-2	242
97403	13230E6653-4-30.5INCH		C-2	231
97403	13230E6653-4-30INCH		C-2	227
97403	13230E6653-4-32INCH		C-2	258
97403	13230E6653-4-4.5INCH		C-2	194
			C-27	47
97403	13230E6653-4-4INCH		C-27	41
97403	13230E6653-4-46INCH		C-2	223
97403	13230E6653-4-5.25INCH		C-27	44
97403	13230E6653-4-6.75INCH		C-27	61
97403	13230E6653-4-6INCH		C-27	39D
			C-27	54
			C-27	54
97403	13230E6653-4-7.25INCH		C-27	65
			C-27	72
97403	13230E6653-4-7INCH		C-27	58
97403	13230E6653-4-8.5INCH		C-27	58
97403	13230E6653-4-8INCH		C-27	61
			C-27	65
			C-27	69
97403	13230E6653-5		BULK	17
97403	13230E6653-5-3INCH		C-11	4F
97403	13230E6653-7		BULK	18
97403	13230E6653-7-10INCH		C-2	197
97403	13230E6653-7-14INCH		C-2	208

SECTION IV

TM 9-6115-670-14&P

PART NUMBER INDEX

CAGEC	PART NUMBER	STOCK NUMBER	FIG.	ITEM
97403	13230E6653-7-22INCH		C-2	200
97403	13230E6653-7-24INCH		C-2	219
97403	13230E6653-7-29INCH		C-2	245
97403	13230E6653-8		BULK	19
97403	13230E6653-8-15INCH		C-2	204
97403	13230E6653-8-2.5 INCH		C-2	169A
			C-2	169B
			C-2	169C
97403	13230E6653-8-28INCH		C-2	178
			C-2	181
			C-2	185
97403	13230E6653-8-6.5INCH		C-2	171
97403	13230E6653-8-7.25INCH		C-2	174
97403	13230E6669-5A		C-2	10
97403	13230E6669-6A		C-2	10
97403	13230E6670		C-6	1
97403	13230E6671-365A	5305-01-479-1212	C-2	161
97403	13230E6673-65L	5305-01-479-1061	C-3	2
97403	13230E6673-66A	5305-01-479-1214	C-2	112I
97403	13230E6673-83A		C-4	8
97403	13230E6674-100A	5305-01-479-1197	C-2	112A
97403	13230E6674-118A	5305-01-479-1199	C-2	17
97403	13230E6674-138A	5305-01-479-1189	C-2	94
			C-2	94
97403	13230E6674-139C	5305-01-479-1193	C-2	29
97403	13230E6674-64A	5305-01-479-1180	C-2	101
			C-2	101
			C-2	117A
97403	13230E6674-66A	5305-01-479-1198	C-2	5
			C-2	11
			C-2	80
97403	13230E6674-67A	5305-01-479-1206	C-2	80
97403	13230E6674-68A		C-2	51
97403	13230E6674-74A	5305-01-479-1201	C-2	87
97403	13230E6674-75A	5305-01-479-1181	C-2	81
97403	13230E6674-76A	5305-01-479-1186	C-2	110
97403	13230E6674-96A	5305-01-479-1190	C-2	27
97403	13230E6674-98A	5305-01-479-1196	C-2	1
			C-2	1
			C-4	18
97403	13230E6674-99A	5305-01-479-1176	C-2	123A
			C-4	14
97403	13230E6678-3	5355-01-478-8487	C-27	16

SECTION IV

TM 9-6115-670-14&P

PART NUMBER INDEX

CAGEC	PART NUMBER	STOCK NUMBER	FIG.	ITEM
97403	13230E6683-7		C-27	36
97403	13230E6685-AD6-7	5320-00-754-0992	C-18	3
97403	13230E6688	2990-01-478-5724	C-2	62
97403	13230E6743-39A		C-2	102
97403	13230E6744-100	5310-01-478-5772	C-2	115
			C-27	34
97403	13230E6744-103		C-2	141A
97403	13230E6744-139	5310-00-933-8121	C-2	28
			C-2	28
			C-27	3
97403	13230E6744-140	5310-01-478-5719	C-2	18
97403	13230E6744-41		C-11	4B
97403	13230E6744-43		C-2	52
97403	13230E6744-44	5310-01-467-6832	C-4	15
97403	13230E6744-45	5310-01-478-5780	C-2	24
97403	13230E6744-46	5310-01-478-5703	C-2	125
			C-4	26
97403	13230E6744-59	5310-01-478-5700	C-2	150
97403	13230E6791	2990-01-478-5686	C-2	54
97403	13230E6792		C-2	61
97403	13230E6812-1		C-2	166A
97403	13230E6813		C-2	47
97403	13230E6816		C-1	3
97403	13230E6820-1		C-2	98
			BULK	9
97403	13230E6820-3		C-2	96
			BULK	10
97403	13230E6820-4		C-2	97
			BULK	11
97403	13230E6821		C-2	99
97403	13230E6846	2935-01-494-6330	C-2	89
97403	13230E6847		C-1	2
97403	13230E6848		C-4	23
97403	13230E6866		C-4	4
97403	13230E6867-2		C-2	106
97403	13230E6868		C-2	129
97403	13230E6869		C-4	24
97403	13230E6870		C-4	19
97403	13230E6871		C-4	20
97403	13230E6872		C-4	25
97403	13230E6873		C-2	112B
97403	13230E6874		C-2	92
97403	13230E6875		C-2	43A
			C-4	2
97403	13230E6877		C-2	112D
97403	13230E6878		C-2	95
97403	13230E6879		C-4	5
97403	13230E6880		C-4	7
97403	13230E6881-1		C-2	123D
97403	13230E6881-2		C-2	123E
97403	13230E6882		C-4	10

SECTION IV

TM 9-6115-670-14&P

PART NUMBER INDEX

CAGEC	PART NUMBER	STOCK NUMBER	FIG.	ITEM
97403	13230E6883-1		C-4	6
97403	13230E6883-2		C-4	9
97403	13230E6888		BULK	1
97403	13230E6888-120		C-26	4
97403	13230E6888-132		C-26	2
97403	13230E6888-60		C-26	2
29381	1323006A		C-4	15
29381	1323007A		C-2	18
			C-2	72A
29381	1324003A		C-2	60
			C-7	3
29381	1324004A		C-2	40
			C-7	8
29381	1324005A		C-2	36
29381	1332100A		C-27	34
29381	1332102A		C-2	112E
OXWR1	13811-33080		C-8	86
04034	140620	5340-01-480-1364	C-6	2
29381	1423005A		C-2	149
29381	1424011A		C-2	117
			C-27	32
OXWR1	14301-43522		C-14	9
OXWR1	14301-43570		C-14	5
OXWR1	14301-43590		C-14	8
OXWR1	14301-43820		C-14	11
S4532	14301-4383-0	5305-01-320-7069	C-14	3
OXWR1	14301-43840	5331-01-320-9566	C-14	10
29381	1434011A		C-2	81
			C-2	120A
			C-18	7
			C-27	10
29381	1452002A		C-2	113
29381	1453041A		C-2	124
29381	1454007A		C-2	148
			C-2	163
			C-27	31
29381	1459027-7INCHES		C-2	9
OXWR1	14601-03450		C-8	38
OXWR1	14601-1311-0	2815-01-478-7450	C-8	33
OXWR1	14601-1312-0	2815-01-478-7465	C-8	32
OXWR1	14601-13240		C-8	30
OXWR1	14601-13330	5340-99-235-4309	C-8	29
S8029	14601-1336-0	2815-99-610-4361	C-8	28
OXWR1	14601-14310	5360-01-486-5154	C-8	24
OXWR1	14601-14410	5307-01-485-8389	C-8	39
OXWR1	15108-57280	5306-01-479-0365	C-8	107
29381	1513006A-20		BULK	2
OXWR1	15221-01750		C-8	36
OXWR1	15221-33650		C-8	169
OXWR1	15221-33700	5331-01-478-5997	C-8	168
OXWR1	15221-88210	5307-01-485-8384	C-8	83

SECTION IV

TM 9-6115-670-14&P

PART NUMBER INDEX

CAGEC	PART NUMBER	STOCK NUMBER	FIG.	ITEM
OXWR1	15231-33960		C-8	164
OXWR1	15231-43560	2940-01-478-9487	C-14	6
OXWR1	15261-03370		C-15	5
OXWR1	15261-21330	5325-01-321-3445	C-8	131
OXWR1	15261-23530	3120-01-478-6117	C-8	144
OXWR1	15261-23540	3120-01-478-6111	C-8	142
OXWR1	15261-23950	3120-01-478-6114	C-8	144
OXWR1	15261-23960	3120-01-478-6113	C-8	144
OXWR1	15261-23970	3120-01-478-6109	C-8	142
OXWR1	15261-23980	3120-01-478-6107	C-8	142
OXWR1	15261-96010		C-8	162
			C-15	6
OXWR1	15261-96160		C-8	159
OXWR1	15263-12370	5330-01-446-2136	C-2	56
29381	1531011A		C-27	5
OXWR1	15321-73340		C-8	167
OXWR1	15321-96260		C-15	4
OXWR1	15393-43580		C-14	7
OXWR1	15441-33520		C-9	19C
OXWR1	15451-96270		C-8	158
OXWR1	15451-96670	2990-01-438-8808	C-9	7
OXWR1	15471-96650		C-9	23
OXWR1	15521-96020		C-8	161
OXWR1	15521-96030		C-8	163
OXWR1	15601-96650	5330-01-478-4911	C-8	7
			C-12	16
OXWR1	15676-73270	5330-01-437-1059	C-10	3
OXWR1	15694-23930	3120-01-478-6123	C-8	143
OXWR1	15694-23940	3120-01-478-6120	C-8	143
OXWR1	15841-04540	5306-01-479-0359	C-8	136
OXWR1	15841-04562	5306-01-479-0360	C-8	138
OXWR1	15841-04810		C-8	150
OXWR1	15841-04822	5330-01-478-5159	C-8	151
OXWR1	15841-05140		C-8	18
OXWR1	15841-05150		C-8	20
OXWR1	15841-05370		C-8	17
OXWR1	15841-05510		C-8	12
OXWR1	15841-0567-0	2815-01-478-7480	C-8	19
OXWR1	15841-13540		C-15	1
OXWR1	15841-13560		C-15	2
OXWR1	15841-1403-0	2815-01-478-7538	C-8	44
OXWR1	15841-14320	5340-01-478-7436	C-8	42
OXWR1	15841-14350		C-8	45
OXWR1	15841-14620	5310-01-478-5177	C-8	8
OXWR1	15841-16320		C-8	113
OXWR1	15841-23250	3110-01-478-6106	C-8	125
OXWR1	15841-24110	3020-01-479-0690	C-8	128
OXWR1	15841-35660	3020-01-486-7671	C-9	12
OXWR1	15841-3693-0	2815-01-478-7478	C-8	76
OXWR1	15841-39010	5930-01-391-8105	C-11	13
OXWR1	15841-51320	4730-01-486-3490	C-13	3

SECTION IV

TM 9-6115-670-14&P

PART NUMBER INDEX

CAGEC	PART NUMBER	STOCK NUMBER	FIG.	ITEM
OXWR1	15841-51350	5305-01-480-1127	C-13	1
OXWR1	15841-53622		C-12	13
OXWR1	15841-54092	2990-01-478-5696	C-8	99
OXWR1	15841-54122	5306-01-479-0366	C-8	102
OXWR1	15841-56110		C-8	94
OXWR1	15841-56480	5360-01-486-3742	C-8	97
OXWR1	15841-57110		C-8	93
OXWR1	15841-57212	5330-01-478-5161	C-8	106
OXWR1	15841-57240	5365-01-485-9240	C-8	109
OXWR1	15841-57920	5360-01-486-5180	C-8	91
OXWR1	15841-72922	5330-01-478-5146	C-10	5
OXWR1	15841-7302-0	4820-01-479-0226	C-8	167
OXWR1	15841-73260		C-10	11
OXWR1	15841-74250		C-10	14
OXWR1	15841-91010	5306-01-479-0355	C-8	77
			C-8	88A
OXWR1	15841-91050	5306-01-479-0327	C-9	14
1Q0C4	15841-91500	5307-01-477-2256	C-12	22
OXWR1	15841-91510		C-10	17
OXWR1	15841-92010	5310-01-478-5178	C-8	90
OXWR1	15841-92020	5310-01-478-5181	C-8	103
OXWR1	15841-92320	5310-01-478-5173	C-12	17
OXWR1	15841-92330	5310-01-478-5186	C-8	104
OXWR1	15841-94022		C-8	41
OXWR1	15841-95680	4730-01-486-3468	C-12	30
OXWR1	15841-96020		C-15	3
OXWR1	15841-96650	5330-01-478-4851	C-13	2
OXWR1	15841-96660	5330-01-478-4849	C-13	4
OXWR1	15846-33110		C-8	84
OXWR1	15852-04360	5330-01-478-5156	C-8	152
OXWR1	15852-25160	5306-01-485-8353	C-8	147
OXWR1	15852-33140	4730-01-436-1167	C-8	9
			C-8	88G
OXWR1	15853-99170		C-9	33
OXWR1	15861-11820	5330-01-478-5164	C-8	63
OXWR1	15861-14263		C-8	25
OXWR1	15861-22970	3120-01-478-6135	C-16	3
OXWR1	15861-22980	3120-01-478-6132	C-16	3
OXWR1	15861-23470	3120-01-478-6131	C-8	135
OXWR1	15861-23860	3120-01-478-6126	C-8	135
			C-8	139
OXWR1	15861-23870	3120-01-478-6125	C-8	135
			C-8	139
OXWR1	15861-23910	3120-01-478-6129	C-8	135
OXWR1	15861-23920	3120-01-478-6128	C-8	135
OXWR1	15862-04132	5330-01-478-5153	C-8	72
OXWR1	15862-11770		C-8	66
OXWR1	15862-12350	5330-01-478-5169	C-8	61
OXWR1	15862-42502		C-12	11
OXWR1	15875-24013	3020-01-486-7673	C-8	119
OXWR1	15875-24250		C-8	121

SECTION IV

TM 9-6115-670-14&P

PART NUMBER INDEX

CAGEC	PART NUMBER	STOCK NUMBER	FIG.	ITEM
OXWR1	15875-24320	5325-01-478-6921	C-8	117
OXWR1	15875-24370		C-8	118
OXWR1	15877-04140	5330-01-478-4887	C-8	82
OXWR1	15881-04026		C-8	71
OXWR1	15881-05550		C-8	11
OXWR1	15881-05590		C-8	15
OXWR1	15881-23310	2815-01-479-0929	C-8	127
OXWR1	15881-72870	4720-01-478-7185	C-10	19
OXWR1	15881-73432		C-10	15
OXWR1	15881-91020	5306-01-479-0335	C-10	7
OXWR1	15881-91030	5306-01-479-0367	C-8	80
OXWR1	16000-56050		C-8	100
OXWR1	16001-53000		C-12	12
OXWR1	16006-51010	2915-01-494-3004	C-12	19
OXWR1	16006-52092	5365-01-437-1065	C-12	20
OXWR1	16006-52112	5365-01-437-1064	C-12	21
OXWR1	16006-52122		C-12	21A
29381	1611034A		C-6	7
29381	1611038A		C-18	9
OXWR1	16241-11640		C-8	46
OXWR1	16241-11720		C-8	67
OXWR1	16241-33360		C-9	25
OXWR1	16241-37080		C-9	31
OXWR1	16241-37200		C-9	36
OXWR1	16241-54420	5340-01-478-7486	C-8	105
OXWR1	16241-72970		C-8	47
OXWR1	16241-73360	4730-01-478-7130	C-9	29
			C-10	8
OXWR1	16241-95800		C-9	22
OXWR1	16264-52140	5330-01-478-6366	C-12	27
31013	16266-01620	5330-01-478-5112	C-9	9
OXWR1	16299-17100		C-8	56
OXWR1	16299-17110		C-8	50
OXWR1	16299-33670	5330-01-478-5144	C-9	16
OXWR1	16299-37010		C-9	34
29381	1651008A		C-2	90
OXWR1	16667-57150		C-8	110
OXWR1	16689-23480		C-8	143
OXWR1	16689-23490		C-8	139
OXWR1	16851-04040		C-8	137
OXWR1	16851-04092		C-8	141
OXWR1	16851-13280		C-8	27
OXWR1	16851-1511-0	2815-01-478-7489	C-8	122
OXWR1	16851-1555-0	2815-01-478-7487	C-8	123
OXWR1	16851-16212		C-8	157
S8029	16851-2111-2	2815-99-553-2023	C-8	129
OXWR1	16851-2131-0	2815-01-478-7493	C-8	133
S8029	16851-2190-0	2815-99-500-2175	C-8	129
OXWR1	16851-21980	3120-01-478-6138	C-16	1
OXWR1	16851-22010	2815-01-479-0672	C-8	132
OXWR1	16851-22140	5306-01-479-0361	C-16	2

SECTION IV

TM 9-6115-670-14&P

PART NUMBER INDEX

CAGEC	PART NUMBER	STOCK NUMBER	FIG.	ITEM
OXWR1	16851-22320	3120-01-478-6137	C-16	3
OXWR1	16851-32110		C-9	2
S8029	16851-3501-0	2815-99-457-4475	C-9	15
OXWR1	16851-35152	5330-01-478-6354	C-9	10
OXWR1	16851-36410		C-9	1
OXWR1	16851-36950	5360-01-486-3739	C-8	74
OXWR1	16851-53712		C-12	10
OXWR1	16851-53722		C-12	9
OXWR1	16851-73350	4720-01-478-7182	C-10	9
OXWR1	16851-91490		C-8	62
OXWR1	16851-96260		C-8	165
OXWR1	16851-96270		C-8	156
OXWR1	16853-21050		C-8	130
OXWR1	16853-21090		C-8	130
OXWR1	16861-04050		C-8	140
OXWR1	16861-14522	5330-01-478-6369	C-8	5
K5F98	16861-16020	2910-99-595-0571	C-8	116
OXWR1	16861-23480	3120-01-478-6124	C-8	143
OXWR1	16861-23490	3120-01-478-6127	C-8	139
OXWR1	16861-25010		C-8	146
OXWR1	16861-53732		C-12	8
OXWR1	16861-65560		C-11	16
OXWR1	16861-93310		C-8	16
OXWR1	16862-14500		C-8	6
OXWR1	16863-01500		C-9	8
OXWR1	16863-23010	2815-01-479-0604	C-8	153
OXWR1	16864-16010		C-8	124
OXWR1	16871-03310	5330-01-478-4843	C-8	34
OXWR1	16871-14430		C-8	43
OXWR1	16873-03042	2815-01-494-7963	C-8	37
OXWR1	16873-72700		C-10	4
OXWR1	16875-74280		C-8	79
OXWR1	16878-57740		C-8	96
OXWR1	16881-01010		C-8	154
OXWR1	16881-03310		C-8	34
OXWR1	16881-04020		C-8	71
OXWR1	16881-04040		C-8	137
OXWR1	16881-04050		C-8	140
OXWR1	16881-04090		C-8	141
OXWR1	16881-11630		C-8	48
OXWR1	16881-11670		C-8	68
OXWR1	16881-11770		C-8	66
OXWR1	16881-12310		C-8	58
OXWR1	16881-12320		C-8	51
OXWR1	16881-17010		C-8	49
OXWR1	16881-21050		C-8	130
OXWR1	16881-21090		C-8	130
OXWR1	16881-21110		C-8	129
OXWR1	16881-21900		C-8	129
OXWR1	16881-23910		C-8	143
OXWR1	16881-23920		C-8	143

SECTION IV

TM 9-6115-670-14&P

PART NUMBER INDEX

CAGEC	PART NUMBER	STOCK NUMBER	FIG.	ITEM
OXWR1	16881-23930		C-8	139
OXWR1	16881-23940		C-8	139
OXWR1	16881-33210		C-9	24
OXWR1	16881-33220		C-9	17
OXWR1	16881-33230		C-9	21
OXWR1	16881-33242		C-9	20
OXWR1	16881-33370		C-9	26
OXWR1	16881-37010		C-9	34
OXWR1	16881-37152		C-9	32
OXWR1	16881-37160		C-9	30
OXWR1	16881-37200		C-9	36
OXWR1	16881-65512	2920-01-478-7511	C-11	18
OXWR1	16881-73172		C-9	28
OXWR1	16881-96010		C-8	69
OXWR1	16881-96750	5331-01-478-5115	C-9	27
OXWR1	16889-72860		C-10	20
			C-10	21
OXWR1	16899-01010		C-8	154
OXWR1	16899-37080		C-9	31
OXWR1	16899-37152		C-9	32
OXWR1	16899-37162		C-9	30
29381	1710001A		C-2	144C
29381	1710006A		C-18	3
OXWR1	17331-59190		C-8	166
29381	1741005A		C-12	3
29381	1741007A		C-2	63
29381	1741008A		C-10	2
29381	1742003A		C-2	69
29381	1743102A		C-2	107
OXWR1	17563-91010		C-8	88B
45152	1788880	5935-01-308-8599	C-5	8
		5340-00-977-3992	C-6	5
OXWR1	19035-52030		C-12	26
OXWR1	19090-11310		C-8	88H
OXWR1	19202-91010	5306-01-479-0352	C-7	9
OXWR1	19203-7301-0	2990-01-436-1329	C-10	10
OXWR1	19204-43010	2910-01-478-8822	C-12	24
OXWR1	19204-43280		C-14	1
OXWR1	19215-99160	5330-01-478-6004	C-8	148
OXWR1	19217-97010	3030-01-490-6137	C-8	81
OXWR1	19265-74110		C-10	13
OXWR1	19298-96020		C-10	4A
OXWR1	19461-56412	5360-01-486-3906	C-8	98
OXWR1	19461-88132		C-8	87
OXWR1	19483-33120		C-8	88J
OXWR1	19666-04620		C-8	147A
OXWR1	19805-72530		C-8	88D
OXWR1	19837-57720		C-8	89
OXWR1	19837-64372	5365-01-485-9244	C-11	12
OXWR1	19883-63010	2310-14-497-4269	C-11	21
OXWR1	19883-64010		C-11	7

SECTION IV

TM 9-6115-670-14&P

PART NUMBER INDEX

CAGEC	PART NUMBER	STOCK NUMBER	FIG.	ITEM
0XWR1	19883-64420		C-11	4
0XWR1	19883-7303-0	2930-01-445-6361	C-10	16
81343	2-2-140239CA		C-5	2
98441	208-3	4720-00-005-5008	BULK	4
29381	2111001A		C-2	184
			C-21	16
29381	2111008A		C-27	64
			C-27	74
			C-28	8
29381	2112003A		C-21	20
29381	2113003A		C-2	261
29381	2126002A		C-21	21
29381	2126003A		C-6	4
29381	2126006A		C-21	18
29381	2160001		C-26	3
29381	2160002		C-20	4
			C-28	10
29381	2160003A		C-22	12
29381	2160004A		C-21	15
29381	2160005A		C-21	17
29381	2173002B		C-2	143
29381	2219002A-8		C-26	5
29381	2219012A-6		C-17	6
29381	2219026A		C-20	7
			C-27	73
29381	2219027A		C-2	246
29381	2231005D		C-27	63
29381	2231006C		C-27	60
29381	2231007C		C-27	52
29381	2231008C		C-27	56
29381	2231009B		C-27	43
29381	2231010D		C-27	49
29381	2231013D		C-2	256
29381	2231023B		C-2	243
29381	2231032A		C-2	260
29381	2231038C		C-2	179
29381	2231039D		C-2	183
29381	2231040A		C-27	70
29381	2233004E		C-2	162
29381	2233005E		C-2	165
29381	2233006E		C-2	122
29381	2233007A		C-1	2
29381	2233009D		C-27	30
29381	2351002A		C-27	26A
29381	2351003A		C-27	18
29381	2351004A		C-27	19
29381	2372002A		C-27	17
98441	243001-10-0380	4720-01-179-2479	BULK	3
53867	3-334-485-008	5935-01-208-3507	C-2	154
00779	3-350820-2	5940-01-082-3321	C-20	2
			C-21	7

SECTION IV

TM 9-6115-670-14&P

PART NUMBER INDEX

CAGEC	PART NUMBER	STOCK NUMBER	FIG.	ITEM
00779	3-350820-2	5940-01-082-3321	C-22	1
			C-28	4
29381	3111001Y	2815-01-494-7123	C-7	1
29381	3112004E		C-2	42
29381	3123006A		C-2	62
29381	3123014A		C-2	54
29381	3124030B		C-2	45
29381	3125002B	2935-01-494-6331	C-2	89
29381	3127008A		C-17	1
67271	322026	2590-01-438-8872	C-12	7
67271	322035	2815-01-439-4961	C-9	3
67271	322084	4730-01-434-3875	C-9	6
67271	322123	2910-01-439-4915	C-12	15
67271	322135		C-12	5
67271	322136		C-12	6
59197	323-421	6685-01-442-2395	C-11	5
29381	3234001A		C-2	12
0XWR1	33430-82760		C-9	19B
99687	344-1013P7	5342-00-684-9456	C-2	32
29381	4110034F		C-2	61
29381	4130026B		C-2	123
29381	4140013A		C-2	144B
29381	4210004D		C-27	1
29381	4210005C		C-27	29
29381	4210008D		C-2	105
29381	4210009C		C-2	86
29381	4210013D		C-2	138
29381	4210014D		C-2	145
29381	4210020C		C-2	20
29381	4210021C		C-2	129
29381	4210023C		C-2	106
29381	4210036C		C-2	152
29381	4210037B		C-2	166
29381	4210038E		C-2	146
29381	4210039A		C-2	128
29381	4210040B		C-2	121
29381	4210042B		C-2	85
29381	4210044A		C-2	84
29381	4210045A		C-2	82
29381	4210061C		C-2	49
29381	4210073A		C-2	134
29381	4210229A		C-2	77
29381	4210230A		C-2	73
29381	4210231A		C-4	17
29381	4210232A		C-4	13
29381	4210261A		C-2	39
29381	4230002D		C-7	6
29381	4230010E		C-2	16
29381	4230022B		C-2	112G
29381	4230092B		C-2	74
29381	4230103A		C-2	6

SECTION IV

TM 9-6115-670-14&P

PART NUMBER INDEX

CAGEC	PART NUMBER	STOCK NUMBER	FIG.	ITEM
29381	4250005B		C-2	33
29381	4250014C		C-2	31
29381	4250078C		C-4	1
29381	4250081A		C-2	108
29381	4250082A		C-2	78
29381	4320001A		C-2	112F
81495	442 6474	5940-01-264-6657	C-2	198
			C-2	201
			C-2	218
			C-2	244
			C-22	2
29381	4610002A		C-2	75
29381	4722253		BULK	13
29381	4732020A		BULK	6
29381	4820045B		C-2	99
29381	4820046B		C-2	44A
29381	4821025A		C-2	112
29381	4831002C	6110-01-494-3003	C-1	1
59138	5SFT-251	5950-01-247-3048	C-2	133
29381	5241017A		C-2	70
29381	5242003A		C-10	23
79470	52487	4820-01-381-5079	C-2	90
10001	67A7A5-1	5961-00-465-4405	C-2	131
30554	69-561-3	5310-00-052-3632	C-2	155
			C-27	37
30554	69-561-5	5310-00-696-5173	C-2	136
30554	69-561-6	5310-01-012-3595	C-2	14
			C-2	14
			C-2	76
			C-18	8
29381	7032916-501		C-1	3
04034	76141	5930-01-262-7827	C-5	5
74400	85000	6645-01-369-2478	C-27	12
30554	88-20018-3		C-20	3
			C-22	9
			C-28	6
30554	88-20033-11A		C-2	53
30554	88-20033-11B	5310-01-478-6341	C-2	116
			C-27	33
30554	88-20033-11C	5310-01-471-0640	C-2	79
			C-2	79
			C-18	4
30554	88-20033-19C	5310-01-478-6346	C-27	2
30554	88-20033-20C	5310-01-471-0633	C-2	2
			C-2	2
30554	88-20033-26C		C-4	27
30554	88-20033-30C		C-4	12
30554	88-20033-33B	5310-01-478-6342	C-2	141
30554	88-20033-33C	5310-01-478-6340	C-2	19
			C-2	19
30554	88-20033-5C	5310-01-478-6344	C-2	23

SECTION IV

TM 9-6115-670-14&P

PART NUMBER INDEX

CAGEC	PART NUMBER	STOCK NUMBER	FIG.	ITEM
30554	88-20033-5C	5310-01-478-6344	C-2	72B
			C-27	9
30554	88-20037WDG8	5340-01-478-7430	C-2	107
30554	88-20042-57A	5305-01-479-0551	C-27	32
30554	88-20546-8		C-2	123B
30554	88-20561-1	4730-01-470-1626	C-12	3
30554	88-20561-2	4730-01-470-2409	C-10	2
30554	88-20561-3	4730-01-470-1567	C-2	46
			C-2	46
30554	88-20564-17		C-11	4C
30554	88-20568-1	5310-01-470-1981	C-2	3
30554	88-20579-2-20INCH		C-12	4
30554	88-20579-2-7INCH		C-12	14
30554	88-20579-4	4720-01-470-6230	BULK	5
30554	88-20579-4-15INCH		C-12	2
30554	88-20579-4-20INCH		C-12	1
30554	88-20579-4-6INCH		C-12	28
30554	88-20579-4-7.5INCH		C-12	23
30554	88-21674-4	5310-01-478-6511	C-2	137
51917	9001KR9RH8	5930-01-155-0768	C-27	26
30554	95-8125-4		C-4	22
29381	9830005A		C-27	16A

FIGURE AND ITEM NUMBER INDEX

FIG.	ITEM	STOCK NUMBER	CAGEC	PART NUMBER
C-1	1	6110-01-494-3003	29381	4831002C
C-1	2	6150-01-482-4325	97403	13230E6308
C-1	2		97403	13230E6847
C-1	2		29381	2233007A
C-1	3		97403	13230E6300
C-1	3		97403	13230E6816
C-1	3		29381	7032916-501
C-2	1	5305-01-479-1196	97403	13230E6674-98A
C-2	1	5305-01-479-1196	97403	13230E6674-98A
C-2	1		29381	1131002A
C-2	2	5310-01-471-0633	30554	88-20033-20C
C-2	2	5310-01-471-0633	30554	88-20033-20C
C-2	2		29381	1313006A
C-2	3	5310-01-470-1981	30554	88-20568-1
C-2	4		05624	N1-1
C-2	5	5305-01-479-1198	97403	13230E6674-66A
C-2	5		05624	BYRF2516
C-2	6		29381	4230103A
C-2	6		05624	DYNK218-2
C-2	7		65149	AKKH175
C-2	8		05624	DYRF29
C-2	9		29381	1459027-7INCHES
C-2	9		05624	DYNK31-006
C-2	10		97403	13230E6669-5A
C-2	10		97403	13230E6669-6A
C-2	11		97403	13230E6674-66A
C-2	12		29381	3234001A
C-2	12		73134	HF3G
C-2	13		81346	ASTMA582-1INCH
C-2	14	5310-01-012-3595	30554	69-561-6
C-2	14		30554	69-561-6
C-2	15		96906	MS35338-43
C-2	16		97403	13230E6337
C-2	16		29381	4230010E
C-2	17	5305-01-479-1199	97403	13230E6674-118A
C-2	17		29381	1122001A
C-2	18	5310-01-478-5719	97403	13230E6744-140
C-2	18		29381	1323007A
C-2	19	5310-01-478-6340	30554	88-20033-33C
C-2	19		30554	88-20033-33C
C-2	19		29381	1313008A
C-2	20		97403	13230E6297
C-2	20		29381	4210020C
C-2	21	2910-01-486-2144	97403	13230E6280

FIGURE AND ITEM NUMBER INDEX

FIG.	ITEM	STOCK NUMBER	CAGEC	PART NUMBER
C-2	22		29381	1132002A
C-2	22		80204	B1821BH031C125N
C-2	23	5310-00-044-6477	96906	MS51412-25
C-2	23	5310-01-478-6344	30554	88-20033-5C
C-2	24	5310-01-478-5780	97403	13230E6744-45
C-2	25	5310-00-767-0445	96906	MS51971-2
C-2	26		97403	13230E6340
C-2	27	5305-01-479-1190	97403	13230E6674-96A
C-2	28	5310-00-933-8121	97403	13230E6744-139
C-2	28		97403	13230E6744-139
C-2	29	5305-01-479-1193	97403	13230E6674-139C
C-2	30	5310-00-984-7042	96906	MS35338-141
C-2	30		96906	MS35338-141
C-2	31		97403	13230E6318
C-2	31		29381	4250014C
C-2	32	5342-00-684-9456	99687	344-1013P7
C-2	33		97403	13230E6315
C-2	33		29381	4250005B
C-2	34		81860	C2060T6
C-2	35	5305-01-480-4690	19008	ISO8676-M10X1.25X25-8.8
C-2	35		19008	ISO8676-M10X1.25X25-8.8
C-2	36		29381	1324005A
C-2	36		29381	1324005A
C-2	37		29381	1143004A
C-2	37		80205	B18235B08070N
C-2	38		29381	1314004A
C-2	38		80204	B1822BS080R
C-2	39		97403	13230E6314
C-2	39		29381	4210261A
C-2	40		29381	1324004A
C-2	40		80204	B18212HRCZ080
C-2	41		80204	B18241B080
C-2	42		97403	13230E6324
C-2	42		29381	3112004E
C-2	43		97403	13230E6333
C-2	43A		97403	13230E6875
C-2	43B		D8286	DYN912-M10X35X1.5X35-8.8
C-2	44A		97403	13230E6649
C-2	44A		29381	4820046B
C-2	44		97403	13230E6328
C-2	45		97403	13230E6329
C-2	45		29381	3124030B
C-2	46	4730-01-470-1567	30554	88-20561-3
C-2	46		30554	88-20561-3

FIGURE AND ITEM NUMBER INDEX

FIG.	ITEM	STOCK NUMBER	CAGEC	PART NUMBER
C-2	47		97403	13230E6813
C-2	48		97403	13218E0493-1810PIIC
C-2	48		80204	B18235B08016N
C-2	49		97403	13230E6334
C-2	49		29381	4210061C
C-2	50		29381	1224012A
C-2	51		97403	13230E6674-68A
C-2	52		97403	13230E6744-43
C-2	53		30554	88-20033-11A
C-2	54	2990-01-478-5686	97403	13230E6791
C-2	54		29381	3123014A
C-2	55		29381	1143002A
C-2	55		80204	B18235B08020N
C-2	56	5330-01-446-2136	0XWR1	15263-12370
C-2	57		0X832	FSP3X9
C-2	58		19008	ISO8676-M10X1.25X25-8.8
C-2	59		29381	1142001A
C-2	60	5310-01-478-5935	05047	W212NAA0060NN041NNCG1
C-2	60		29381	1324003A
C-2	61		97403	13230E6792
C-2	61		29381	4110034F
C-2	62	2990-01-478-5724	97403	13230E6688
C-2	62		29381	3123006A
C-2	63		29381	1741007A
C-2	64	2990-01-485-7699	97403	13230E6317
C-2	65	2990-01-478-6488	97403	13230E6327
C-2	66		97403	13230E6316
C-2	67		58536	AA52406-3-SB
C-2	68	2990-01-478-6489	97403	13230E6310
C-2	69		29381	1742003A
C-2	70		97403	13230E6335
C-2	70		29381	5241017A
C-2	71	5310-00-913-8881	97403	13218E0320-293
C-2	71		97403	13218E0320-293
C-2	72		29381	1132006A
C-2	72A		29381	1323007A
C-2	72B	5310-01-478-6344	30554	88-20033-5C
C-2	73		97403	13230E6645
C-2	73		29381	4210230A
C-2	74	5306-01-479-3983	97403	13230E6347
C-2	74		29381	4230092B
C-2	75	5342-01-478-7900	97403	13230E6644-1
C-2	75		29381	4610002A
C-2	76		97403	13218E0320-89

FIGURE AND ITEM NUMBER INDEX

FIG.	ITEM	STOCK NUMBER	CAGEC	PART NUMBER
C-2	76		30554	69-561-6
C-2	76A	5310-00-933-8120	96906	MS35338-138
C-2	77		97403	13230E6346
C-2	77		29381	4210229A
C-2	78		97403	13230E6345
C-2	78		29381	4250082A
C-2	79	5310-01-471-0640	30554	88-20033-11C
C-2	79		29381	1313004A
C-2	79		97403	13230E6674-67A
C-2	80	5305-01-479-1206	97403	13230E6674-67A
C-2	80		97403	13230E6674-66A
C-2	81	5305-01-479-1181	97403	13230E6674-75A
C-2	81		29381	1434011A
C-2	82	5310-01-478-5208	97403	13230E6294
C-2	82		29381	4210045A
C-2	83		97403	13230E6292-1-46INCH
C-2	84		97403	13230E6289
C-2	84		29381	4210044A
C-2	85		97403	13230E6287
C-2	85		29381	4210042B
C-2	86		97403	13230E6290
C-2	86		29381	4210009C
C-2	87	5305-01-479-1201	97403	13230E6674-74A
C-2	88	2930-01-146-3634	72853	10230
C-2	89	2930-01-479-1801	97403	13230E6282
C-2	89	2935-01-494-6330	97403	13230E6846
C-2	89	2935-01-494-6331	29381	3125002B
C-2	90	4820-01-381-5079	79470	52487
C-2	90		29381	1651008A
C-2	91		78553	C7941-1024-3B
C-2	92		97403	13230E6874
C-2	93	5310-01-478-4828	97403	13230E6326
C-2	94	5305-01-479-1189	97403	13230E6674-138A
C-2	94		29381	1133003A
C-2	94		97403	13230E6674-138A
C-2	95		97403	13230E6878
C-2	96		97403	13230E6820-3
C-2	97		97403	13230E6820-4
C-2	98		97403	13230E6820-1
C-2	99		97403	13230E6821
C-2	99		29381	4820045B
C-2	100		97403	13230E6299
C-2	101	5305-01-479-1180	97403	13230E6674-64A
C-2	101		97403	13230E6674-64A
C-2	102		97403	13230E6743-39A

FIGURE AND ITEM NUMBER INDEX

FIG.	ITEM	STOCK NUMBER	CAGEC	PART NUMBER
C-2	103		29381	1313004A
C-2	104		29381	1224201A
C-2	104		78553	C7931-1024-3B
C-2	105		97403	13230E6291
C-2	105		29381	4210008D
C-2	106		97403	13230E6286
C-2	106		97403	13230E6867-2
C-2	106		29381	4210023C
C-2	107	5340-01-478-7430	30554	88-20037WDG8
C-2	107		29381	1743102A
C-2	108		97403	13230E6342
C-2	108		29381	4250081A
C-2	109		I9008	ISO8676-M10X1.25X20-8.8
C-2	110	5305-01-479-1186	97403	13230E6674-76A
C-2	111	4720-01-479-1362	97403	13230E6343
C-2	112	2915-01-478-6910	97403	13230E6344
C-2	112		29381	4821025A
C-2	112A	5305-01-479-1197	97403	13230E6674-100A
C-2	112B		97403	13230E6873
C-2	112C		97403	13230E6295
C-2	112D		97403	13230E6877
C-2	112E		29381	1332102A
C-2	112F		97403	13230E6271
C-2	112F		29381	4320001A
C-2	112G		97403	13230E6273
C-2	112G		29381	4230022B
C-2	112H		29381	1224012A
C-2	112I	5305-01-479-1214	97403	13230E6673-66A
C-2	113	5342-01-478-7932	97403	13230E6274-1
C-2	113		29381	1452002A
C-2	114	5310-01-478-9244	97403	13218E0320-129
C-2	114A		29381	1224011A
C-2	115	5310-01-478-5772	97403	13230E6744-100
C-2	116	5310-01-478-6341	30554	88-20033-11B
C-2	117	5305-00-417-4955	98897	LS12906-87
C-2	117		29381	1424011A
C-2	117A		97403	13230E6674-64A
C-2	118	2990-01-478-5699	97403	13230E6251
C-2	119		97403	13230E6268
C-2	119A		97403	13230E6219
C-2	119B	5320-00-932-1972	97403	13214E3789-2
C-2	120		97403	13230E6272
C-2	120A		29381	1434011A
C-2	121		97403	13230E6269
C-2	121		29381	4210040B

FIGURE AND ITEM NUMBER INDEX

FIG.	ITEM	STOCK NUMBER	CAGEC	PART NUMBER
C-2	121A		29381	1224201A
C-2	122		97403	13230E6260
C-2	122		29381	2233006E
C-2	122A		29381	1143006A
C-2	123		97403	13230E6332
C-2	123		29381	4130026B
C-2	123A	5305-01-479-1176	97403	13230E6674-99A
C-2	123B		30554	88-20546-8
C-2	123C	5310-00-250-9477	97403	13218E0320-291
C-2	123D		97403	13230E6881-1
C-2	123E		97403	13230E6881-2
C-2	123F		80204	B1821BH038C200N
C-2	123G		80204	B1821BH038C250N
C-2	124		29381	1453041A
C-2	124A		29381	1321008A
C-2	124B		29381	1211009A
C-2	125	5310-01-478-5703	97403	13230E6744-46
C-2	126		29381	1143002A
C-2	126		80204	B1821BH038C088N
C-2	127		80204	B1821BH038C075N
C-2	128		97403	13230E6270
C-2	128		29381	4210039A
C-2	129		97403	13230E6312
C-2	129		97403	13230E6868
C-2	129		29381	4210021C
C-2	130	6110-01-485-9791	97403	13230E6254
C-2	131	5961-00-465-4405	10001	67A7A5-1
C-2	132	5925-01-478-5111	97403	13230E6253
C-2	133	5950-01-247-3048	59138	5SFT-251
C-2	134		97403	13230E6262
C-2	134		29381	4210073A
C-2	135		97403	13230E6274-1
C-2	136	5310-00-696-5173	30554	69-561-5
C-2	137	5310-01-478-6511	30554	88-21674-4
C-2	138		97403	13230E6267
C-2	138		29381	4210013D
C-2	139	5310-01-478-8451	97403	13218E0320-333
C-2	140		96906	MS35333-110
C-2	141	5310-01-478-6342	30554	88-20033-33B
C-2	141A		97403	13230E6744-103
C-2	142		97403	13230E6275
C-2	143	5940-01-478-5485	97403	13230E6256
C-2	143		29381	2173002B
C-2	144	5307-01-486-0464	97403	13230E6276
C-2	144A		29381	1224001A

FIGURE AND ITEM NUMBER INDEX

FIG.	ITEM	STOCK NUMBER	CAGEC	PART NUMBER
C-2	144B		29381	4140013A
C-2	144C		29381	1710001A
C-2	145		97403	13230E6266
C-2	145		29381	4210014D
C-2	146	5340-01-486-5978	97403	13230E6263
C-2	146		29381	4210038E
C-2	147	5305-01-479-1844	97403	13218E0493-349PI IC
C-2	147		97403	13218E0493-350PIIC
C-2	148	5305-01-479-1842	97403	13218E0493-354PIIC
C-2	148		29381	1454007A
C-2	149	5305-01-479-1841	97403	13218E0493-345PIIC
C-2	149		29381	1423005A
C-2	150	5310-01-478-5700	97403	13230E6744-59
C-2	151	5310-00-934-9739	96906	MS35649-242
C-2	151		29381	1224017A
C-2	152		97403	13230E6265
C-2	152		29381	4210036C
C-2	153	5945-01-382-8925	77342	VF4-15H11-S05
C-2	154	5935-01-208-3507	53867	3-334-485-008
C-2	155	5310-00-052-3632	30554	69-561-3
C-2	155		29381	1224015A
C-2	155A		97403	13230E6231-4
C-2	156	5325-00-276-6343	96906	MS35489-23
C-2	157	5310-01-478-9268	97403	13218E0320-248
C-2	157		29381	1224017A
C-2	158	6110-01-478-6439	97403	13230E6252
C-2	159		97403	13230E6249
C-2	160		97403	13230E6248
C-2	161	5305-01-479-1212	97403	13230E6671-365A
C-2	162	6150-01-479-0594	97403	13230E6258
C-2	162		29381	2233004E
C-2	163	5305-01-479-1839	97403	13218E0493-289PIIC
C-2	163		29381	1454007A
C-2	164	6115-01-484-6250	97403	13230E6302
C-2	165		97403	13230E6261
C-2	165		29381	2233005E
C-2	166		97403	13230E6264
C-2	166		29381	4210037B
C-2	166A		97403	13230E6812-1
C-2	167	5945-01-479-0301	97403	13230E6279
C-2	168		97403	13230E6232-16
C-2	168A		97403	13230E6232-34
C-2	168B		97403	13230E6232-35
C-2	168C		97403	13230E6232-36
C-2	169		97403	13230E6653-4-14INCH

FIGURE AND ITEM NUMBER INDEX

FIG	ITEM	STOCK NUMBER	CAGEC	PART NUMBER
C-2	169B		97403	13230E6653-8-2.5INCH
C-2	169C		97403	13230E6653-8-2.5INCH
C-2	170		97403	13230E6232-19
C-2	171		97403	13230E6653-8-6.5INCH
C-2	172	5940-00-113-9826	97403	13226E0107-23
C-2	173		97403	13230E6232-20
C-2	174		97403	13230E6653-8-7.25INCH
C-2	175		97403	13226E0107-23
C-2	176		97403	13230E6232-17
C-2	177		97403	13226E0107-23
C-2	178		97403	13230E6653-8-28INCH
C-2	179		29381	2231038C
C-2	180	5940-00-113-8183	96906	MS25036-113
C-2	181		97403	13230E6653-8-28INCH
C-2	182		97403	13226E0107-23
C-2	183		29381	2231039D
C-2	184		29381	2111001A
C-2	185		97403	13230E6653-8-28INCH
C-2	186		96906	MS25036-113
C-2	187		97403	13230E6259
C-2	188	5940-01-478-6050	97403	13230E6236-2
C-2	189		56501	A-250
C-2	190		97403	13230E6653-4-24INCH
C-2	191	5940-00-143-4771	96906	MS-25036-103
C-2	192		97403	13230E6232-15
C-2	193		56501	A-250
C-2	194		97403	13230E6653-4-4.5INCH
C-2	195		97403	13230E6232-21
C-2	196		97403	13226E0107-23
C-2	197		97403	13230E6653-7-10INCH
C-2	198	5940-01-264-6657	81495	442 6474
C-2	199		97403	13230E6232-18
C-2	200		97403	13230E6653-7-22INCH
C-2	201		81495	4426474
C-2	202		97403	13230E6232-22
C-2	203		97403	13226E0107-23
C-2	204		97403	13230E6653-8-15INCH
C-2	205		96906	MS25036-113
C-2	206		97403	13230E6232-23
C-2	207		97403	13226E0107-23
C-2	208		97403	13230E6653-7-14INCH
C-2	209	5940-00-143-4794	81343	MS25036-112
C-2	210		97403	13230E6232-28
C-2	211	5940-01-052-7646	14726	S05300F

FIGURE AND ITEM NUMBER INDEX

FIG.	ITEM	STOCK NUMBER	CAGEC	PART NUMBER
C-2	212		97403	13230E6653-4-17INCH
C-2	213		97403	13230E6232-29
C-2	214		14726	S05300F
C-2	215		97403	13230E6653-4-24INCH
C-2	216	5940-00-143-4773	97403	13217E3854-5
C-2	217		97403	13230E6232-24
C-2	218		81495	4426474
C-2	219		97403	13230E6653-7-24INCH
C-2	220		97403	13226E0107-23
C-2	221		97403	13230E6232-33
C-2	222		96906	MS25036-103
C-2	223		97403	13230E6653-4-46INCH
C-2	224		14726	S05300F
C-2	225		97403	13230E6232-30
C-2	226		97403	13217E3854-5
C-2	227		97403	13230E6653-4-30INCH
C-2	228		14726	S05300F
C-2	229		97403	13230E6232-31
C-2	230		97403	13217E3854-5
C-2	231		97403	13230E6653-4-30.5INCH
C-2	232		14726	S05300F
C-2	233		97403	13230E6232-26
C-2	234		14726	S05300F
C-2	235		97403	13230E6653-4-26. 62INCH
C-2	236		56501	A-250
C-2	237		97403	13230E6232-27
C-2	238		14726	S05300F
C-2	239		97403	13230E6653-4-18.5INCH
C-2	240		97403	13230E6232-37ZZ
C-2	241		14726	S05300F
C-2	242		97403	13230E6653-4-3INCH
C-2	243		29381	2231023B
C-2	244		81495	4426474
C-2	245		97403	13230E6653-7-29INCH
C-2	246		29381	2219027A
C-2	247		97403	13226E0107-23
C-2	248		97403	13230E6232-32
C-2	249		96906	MS25036-103
C-2	250		97403	13230E6653-4-26.5INCH
C-2	251		14726	S05300F
C-2	252		97403	13230E6232-25
C-2	253		14726	S05300F
C-2	254		97403	13230E6653-4-28INCH
C-2	255		56501	A-250

FIGURE AND ITEM NUMBER INDEX

C-2	256		29381	2231013D
C-2	257		14726	S05300F
C-2	258		97403	13230E6653-4-32INCH
C-2	259		97403	13230E6236-2
C-2	260		29381	2231032A
C-2	261		29381	2113003A
C-2	262		97403	13230E6653-4-2INCH
C-3	1		97403	13230E6301
C-3	2	5305-01-479-1061	97403	13230E6673-65L
C-3	3		97403	13230E6293
C-3	4		97403	13230E6292-2-11INCH
C-4	1		97403	13230E6648
C-4	1		29381	4250078C
C-4	2		97403	13230E6875
C-4	3		D8286	DYN912-M10X35X1.5X35-8.8
C-4	4		97403	13230E6866
C-4	5		97403	13230E6879
C-4	6		97403	13230E6883-1
C-4	7		97403	13230E6880
C-4	8		97403	13230E6673-83A
C-4	9		97403	13230E6883-2
C-4	10		97403	13230E6882
C-4	11		81346	B1821BH38C100N
C-4	12		30554	88-20033-30C
C-4	13		97403	13230E6646
C-4	13		29381	4210232A
C-4	14		29381	1131001A
C-4	14		97403	13230E6674-99A
C-4	15	5310-01-467-6832	97403	13230E6744-44
C-4	15		29381	1323006A
C-4	16	5310-00-809-4058	96906	MS27183-10
C-4	17		97403	13230E6647
C-4	17		29381	4210231A
C-4	18		97403	13230E6674-98A
C-4	19		97403	13230E6870
C-4	20		97403	13230E6871
C-4	21		97403	13218E0493-2765
C-4	22		30554	95-8125-4
C-4	23		97403	13230E6848
C-4	24		97403	13230E6869
C-4	25		97403	13230E6872
C-4	26		97403	13230E6744-46
C-4	27		30554	88-20033-26C
C-5	1	4730-01-017-5119	97403	13217E7108-17
C-5	2		81343	2-2-140239CA
C-5	3		97403	13230E6298

FIGURE AND ITEM NUMBER INDEX

FIG.	ITEM	STOCK NUMBER	CAGEC	PART NUMBER
C-5	4	4730-00-595-1721	97403	13217E7108-5
C-5	5	5930-01-262-7827	04034	76141
C-5	6		97403	13230E6242-6
C-5	7		97403	13230E6240-1
C-5	8	5935-01-308-8599	45152	1788880
C-6	1		97403	13230E6670
C-6	2	5340-01-480-1364	04034	140620
C-6	3	5975-01-310-5011	77060	12015323
C-6	4	5999-01-323-4929	77060	1208 9188
C-6	4		29381	2126003A
C-6	5	5340-00-977-3992	45152	1788880
C-6	6		97403	13217E7108-5
C-6	7	4730-00-226-8874	19207	12325823
C-6	7		29381	1611034A
C-6	8		97403	13217E7108-17
C-7	1	2815-01-456-6955	97403	13230E6303
C-7	1	2815-01-494-7123	29381	3111001Y
C-7	2		29381	1142007A
C-7	2		80204	B18235B06050N
C-7	3		05043	W212NAA0060NN041NCG1
C-7	3		29381	1324003A
C-7	4		97403	13230E6307
C-7	5		97403	13230E6323
C-7	6		97403	13230E6322
C-7	6		29381	4230002D
C-7	7		80204	B18235B08020-1
C-7	7		80204	B18235B08020-1
C-7	7		29381	1143002A
C-7	8		80204	B18212HRCZ080
C-7	8		80204	B18212HRCZ080
C-7	8		29381	1324004A
C-7	9	5306-01-479-0352	0XWR1	19202-91010
C-7	9		29381	1142004A
C-8	1		97403	SYSTEM-4
C-8	2		97403	SYSTEM-2
C-8	3		97403	SYSTEM-3
C-8	4		97403	SYSTEM-1
C-8	5	5330-01-478-6369	0XWR1	16861-14522
C-8	6		0XWR1	16862-14500
C-8	7	5330-01-478-4911	0XWR1	15601-96650
C-8	8	5310-01-478-5177	0XWR1	15841-14620
C-8	9	4730-01-436-1167	0XWR1	15852-33140
C-8	10	5331-01-320-9557	0XWR1	04811-50300
C-8	11		0XWR1	15881-05550

FIGURE AND ITEM NUMBER INDEX

FIG.	ITEM	STOCK NUMBER	CAGEC	PART NUMBER
C-8	12		0XWR1	15841-05510
C-8	13	5310-01-320-7060	0XWR1	02114-50080
C-8	14	5310-01-478-5120	0XWR1	04013-60080
C-8	15		0XWR1	15881-05590
C-8	16		0XWR1	16861-93310
C-8	17		0XWR1	15841-05370
C-8	18		0XWR1	15841-05140
C-8	19	2815-01-478-7480	0XWR1	15841-0567-0
C-8	20		0XWR1	15841-05150
C-8	21	5310-01-320-7038	0XWR1	02056-50060
C-8	22	5310-01-320-7100	0XWR1	04512-60060
C-8	23	5310-01-478-5171	0XWR1	04012-50060
C-8	24	5360-01-486-5154	0XWR1	14601-14310
C-8	25		0XWR1	15861-14263
C-8	26		0XWR1	05411-00420
C-8	27		0XWR1	16851-13280
C-8	28	2815-99-610-4361	S8029	14601-1336-0
C-8	29	5340-99-235-4309	0XWR1	14601-13330
C-8	30		0XWR1	14601-13240
C-8	31	5330-01-478-6002	0XWR1	11420-13150
C-8	32	2815-01-478-7465	0XWR1	14601-1312-0
C-8	33	2815-01-478-7450	0XWR1	14601-1311-0
C-8	34	5330-01-478-4843	0XWR1	16871-03310
C-8	34		0XWR1	16881-03310
C-8	35		0XWR1	01123-60816
C-8	36		0XWR1	15221-01750
C-8	37	2815-01-494-7963	0XWR1	16873-03042
C-8	38		0XWR1	14601-03450
C-8	39	5307-01-485-8389	0XWR1	14601-14410
C-8	40	5306-01-393-4861	31013	01023-50610
C-8	41		0XWR1	15841-94022
C-8	42	5340-01-478-7436	0XWR1	15841-14320
C-8	43		0XWR1	16871-14430
C-8	44	2815-01-478-7538	0XWR1	15841-1403-0
C-8	45		0XWR1	15841-14350
C-8	46		0XWR1	16241-11640
C-8	47		0XWR1	16241-72970
C-8	48		0XWR1	16881-11630
C-8	49		0XWR1	16881-17010
C-8	50		0XWR1	16299-17110
C-8	51		0XWR1	16881-12320
C-8	52	5305-14-514-1576	0XWR1	01123-50828
C-8	53		0XWR1	04512-60080
C-8	54	5306-01-479-0369	0XWR1	01311-10828

FIGURE AND ITEM NUMBER INDEX

FIG.	ITEM	STOCK NUMBER	CAGEC	PART NUMBER
C-8	55	5307-01-485-8363	0XWR1	01513-50828
C-8	55A	5310-01-393-6781	31013	02156-50080
C-8	56		0XWR1	16299-17100
C-8	57		0XWR1	01513-60820
C-8	58		0XWR1	16881-12310
C-8	59	5310-01-478-5187	0XWR1	02756-50060
C-8	60		0XWR1	01759-50616
C-8	61	5330-01-478-5169	0XWR1	15862-12350
C-8	62		0XWR1	16851-91490
C-8	63	5330-01-478-5164	0XWR1	15861-11820
C-8	64	5305-14-514-1569	0XWR1	01023-50618
C-8	65		0XWR1	01023-50645
C-8	66		0XWR1	15862-11770
C-8	66		0XWR1	16881-11770
C-8	67		0XWR1	16241-11720
C-8	68		0XWR1	16881-11670
C-8	69		0XWR1	16881-96010
C-8	70		0XWR1	04724-00140
C-8	71		0XWR1	15881-04026
C-8	71		0XWR1	16881-04020
C-8	72	5330-01-478-5153	0XWR1	15862-04132
C-8	73	5331-01-478-4867	0XWR1	04811-06130
C-8	74	5360-01-486-3739	0XWR1	16851-36950
C-8	75	4820-01-478-7226	0XWR1	07715-03211
C-8	76	2815-01-478-7478	0XWR1	15841-3693-0
C-8	77	5306-01-479-0355	0XWR1	15841-91010
C-8	78	2940-99-980-8342	S8029	01023-50675
C-8	79		0XWR1	16875-74280
C-8	80	5306-01-479-0367	0XWR1	15881-91030
C-8	81	3030-01-490-6137	0XWR1	19217-97010
C-8	82	5330-01-478-4887	0XWR1	15877-04140
C-8	82A		0XWR1	01023-60650
C-8	83	5307-01-485-8384	0XWR1	15221-88210
C-8	84		0XWR1	15846-33110
C-8	85	5331-01-478-4865	0XWR1	04811-06230
C-8	86		0XWR1	13811-33080
C-8	87		0XWR1	19461-88132
C-8	88		0XWR1	01023-60670
C-8	88A		0XWR1	15841-91010
C-8	88B		0XWR1	17563-91010
C-8	88C	5306-01-435-8407	0XWR1	01023-50680
C-8	88D		0XWR1	19805-72530
C-8	88E		0XWR1	01023-60650
C-8	88F		0XWR1	01023-50660

FIGURE AND ITEM NUMBER INDEX

FIG.	ITEM	STOCK NUMBER	CAGEC	PART NUMBER
C-8	88G		0XWR1	15852-33140
C-8	88H		0XWR1	19090-11310
C-8	88J		0XWR1	19483-33120
C-8	89		0XWR1	19837-57720
C-8	90	5310-01-478-5178	0XWR1	15841-92010
C-8	91	5360-01-486-5180	0XWR1	15841-57920
C-8	92	5305-14-514-1572	0XWR1	01053-50618
C-8	93		0XWR1	15841-57110
C-8	94		0XWR1	15841-56110
C-8	95	5331-01-478-5999	0XWR1	04811-10070
C-8	96		0XWR1	16878-57740
C-8	97	5360-01-486-3742	0XWR1	15841-56480
C-8	98	5360-01-486-3906	0XWR1	19461-56412
C-8	99	2990-01-478-5696	0XWR1	15841-54092
C-8	100		0XWR1	16000-56050
C-8	101	5306-01-479-0363	0XWR1	01023-50635
C-8	102	5306-01-479-0366	0XWR1	15841-54122
C-8	103	5310-01-478-5181	0XWR1	15841-92020
C-8	104	5310-01-478-5186	0XWR1	15841-92330
C-8	105	5340-01-478-7486	0XWR1	16241-54420
C-8	106	5330-01-478-5161	0XWR1	15841-57212
C-8	107	5306-01-479-0365	0XWR1	15108-57280
C-8	108	5331-01-478-4863	0XWR1	04811-10160
C-8	109	5365-01-485-9240	0XWR1	15841-57240
C-8	110		0XWR1	16667-57150
C-8	111	5315-01-478-6939	0XWR1	05411-00318
C-8	112	5306-01-321-3371	S4532	01023-50612
C-8	113		0XWR1	15841-16320
C-8	114	3130-01-485-9253	0XWR1	08103-06203
C-8	115	5325-01-486-3846	0XWR1	04612-00170
C-8	116	2910-99-595-0571	K5F98	16861-16020
C-8	117	5325-01-478-6921	0XWR1	15875-24320
C-8	118		0XWR1	15875-24370
C-8	119	3020-01-486-7673	0XWR1	15875-24013
C-8	120	5306-01-320-7024	S4532	01023-50614
C-8	121		0XWR1	15875-24250
C-8	122	2815-01-478-7489	0XWR1	16851-1511-0
C-8	123	2815-01-478-7487	0XWR1	16851-1555-0
C-8	124		0XWR1	16864-16010
C-8	125	3110-01-478-6106	0XWR1	15841-23250
C-8	126	5331-01-478-4864	0XWR1	04811-16220
C-8	127	2815-01-479-0929	0XWR1	15881-23310
C-8	128	3020-01-479-0690	0XWR1	15841-24110
C-8	129	2815-99-500-2175	S8029	16851-2190-0

FIGURE AND ITEM NUMBER INDEX

FIG.	ITEM	STOCK NUMBER	CAGEC	PART NUMBER
C-8	129	2815-99-553-2023	S8029	16851-2111-2
C-8	129		0XWR1	16881-21110
C-8	129		0XWR1	16881-21900
C-8	130		0XWR1	16853-21050
C-8	130		0XWR1	16853-21090
C-8	130		0XWR1	16881-21050
C-8	130		0XWR1	16881-21090
C-8	131	5325-01-321-3445	0XWR1	15261-21330
C-8	132	2815-01-479-0672	0XWR1	16851-22010
C-8	133	2815-01-478-7493	0XWR1	16851-2131-0
C-8	134	5315-01-321-2001	0XWR1	05712-00515
C-8	135	3120-01-478-6125	0XWR1	15861-23870
C-8	135	3120-01-478-6126	0XWR1	15861-23860
C-8	135	3120-01-478-6128	0XWR1	15861-23920
C-8	135	3120-01-478-6129	0XWR1	15861-23910
C-8	135	3120-01-478-6131	0XWR1	15861-23470
C-8	136	5306-01-479-0359	0XWR1	15841-04540
C-8	137		0XWR1	16851-04040
C-8	137		0XWR1	16881-04040
C-8	138	5306-01-479-0360	0XWR1	15841-04562
C-8	139	3120-01-478-6127	0XWR1	16861-23490
C-8	139		0XWR1	15861-23860
C-8	139		0XWR1	15861-23870
C-8	139		0XWR1	16689-23490
C-8	139		0XWR1	16881-23930
C-8	139		0XWR1	16881-23940
C-8	140		0XWR1	16861-04050
C-8	140		0XWR1	16881-04050
C-8	141		0XWR1	16851-04092
C-8	141		0XWR1	16881-04090
C-8	142	3120-01-478-6107	0XWR1	15261-23980
C-8	142	3120-01-478-6109	0XWR1	15261-23970
C-8	142	3120-01-478-6111	0XWR1	15261-23540
C-8	143	3120-01-478-6120	0XWR1	15694-23940
C-8	143	3120-01-478-6123	0XWR1	15694-23930
C-8	143	3120-01-478-6124	0XWR1	16861-23480
C-8	143		0XWR1	16689-23480
C-8	143		0XWR1	16881-23910
C-8	143		0XWR1	16881-23920
C-8	144	3120-01-478-6113	0XWR1	15261-23960
C-8	144	3120-01-478-6114	0XWR1	15261-23950
C-8	144	3120-01-478-6117	0XWR1	15261-23530
C-8	145	5306-01-321-3372	0XWR1	01023-50622
C-8	146		0XWR1	16861-25010

FIGURE AND ITEM NUMBER INDEX

FIG.	ITEM	STOCK NUMBER	CAGEC	PART NUMBER
C-8	147	5306-01-485-8353	0XWR1	15852-25160
C-8	147A		0XWR1	19666-04620
C-8	147B		0XWR1	01123-60816
C-8	148	5330-01-478-6004	0XWR1	19215-99160
C-8	149	5306-01-321-3375	S4532	01023-50620
C-8	150		0XWR1	15841-04810
C-8	151	5330-01-478-5159	0XWR1	15841-04822
C-8	152	5330-01-478-5156	0XWR1	15852-04360
C-8	153	2815-01-479-0604	0XWR1	16863-23010
C-8	154		0XWR1	16881-01010
C-8	154		0XWR1	16899-01010
C-8	155		0XWR1	05012-00508
C-8	156		0XWR1	16851-96270
C-8	157		0XWR1	16851-16212
C-8	158		0XWR1	15451-96270
C-8	159		0XWR1	15261-96160
C-8	160		0XWR1	05012-00814
C-8	161		0XWR1	15521-96020
C-8	162		0XWR1	15261-96010
C-8	163		0XWR1	15521-96030
C-8	164		0XWR1	15231-33960
C-8	165		0XWR1	16851-96260
C-8	166		0XWR1	17331-59190
C-8	167	4820-01-479-0226	0XWR1	15841-7302-0
C-8	167		0XWR1	15321-73340
C-8	168	5331-01-478-5997	0XWR1	15221-33700
C-8	169		0XWR1	15221-33650
C-9	1		0XWR1	16851-36410
C-9	2		0XWR1	16851-32110
C-9	3	2815-01-439-4961	67271	322035
C-9	4		0XWR1	01123-60814
C-9	5		S4532	01023-50612
C-9	6	4730-01-434-3875	67271	322084
C-9	7	2990-01-438-8808	0XWR1	15451-96670
C-9	8		0XWR1	16863-01500
C-9	9	5330-01-478-5112	31013	16266-01620
C-9	10	5330-01-478-6354	0XWR1	16851-35152
C-9	11	5315-01-486-1942	0XWR1	05712-00408
C-9	12	3020-01-486-7671	0XWR1	15841-35660
C-9	13	5310-01-478-5170	0XWR1	02783-50100
C-9	14	5306-01-479-0327	0XWR1	15841-91050
C-9	15	2815-99-457-4475	S8029	16851-3501-0
C-9	16	5330-01-478-5144	0XWR1	16299-33670
C-9	17		0XWR1	16881-33220

FIGURE AND ITEM NUMBER INDEX

FIG.	ITEM	STOCK NUMBER	CAGEC	PART NUMBER
C-9	18		S4532	01023-50620
C-9	19	4730-01-478-7123	0XWR1	09318-88200
C-9	19A		0XWR1	09318-88180
C-9	19B		0XWR1	33430-82760
C-9	19C		0XWR1	15441-33520
C-9	20		0XWR1	16881-33242
C-9	21		0XWR1	16881-33230
C-9	22		0XWR1	16241-95800
C-9	23		0XWR1	15471-96650
C-9	24		0XWR1	16881-33210
C-9	25		0XWR1	16241-33360
C-9	26		0XWR1	16881-33370
C-9	27	5331-01-478-5115	0XWR1	16881-96750
C-9	28		0XWR1	16881-73172
C-9	29	4730-01-478-7130	0XWR1	16241-73360
C-9	30		0XWR1	16881-37160
C-9	30		0XWR1	16899-37162
C-9	31		0XWR1	16241-37080
C-9	31		0XWR1	16899-37080
C-9	32		0XWR1	16881-37152
C-9	32		0XWR1	16899-37152
C-9	33		0XWR1	15853-99170
C-9	34		0XWR1	16299-37010
C-9	34		0XWR1	16881-37010
C-9	35	5331-01-478-4871	0XWR1	04814-50600
C-9	36		0XWR1	16241-37200
C-9	36		0XWR1	16881-37200
C-10	1	4720-01-478-6491	97403	13230E6330
C-10	2	4730-01-470-2409	30554	88-20561-2
C-10	2		29381	1741008A
C-10	2A		0XWR1	01023-50622
C-10	3	5330-01-437-1059	0XWR1	15676-73270
C-10	4		0XWR1	16873-72700
C-10	4A		0XWR1	19298-96020
C-10	5	5330-01-478-5146	0XWR1	15841-72922
C-10	6	5306-01-321-7025	S4532	01023-50616
C-10	7	5306-01-479-0335	0XWR1	15881-91020
C-10	8		0XWR1	16241-73360
C-10	9	4720-01-478-7182	0XWR1	16851-73350
C-10	10		0XWR1	19203-7301-0
C-10	11		0XWR1	15841-73260
C-10	12		31013	01754-50610
C-10	13		0XWR1	19265-74110
C-10	14		0XWR1	15841-74250

FIGURE AND ITEM NUMBER INDEX

FIG.	ITEM	STOCK NUMBER	CAGEC	PART NUMBER
C-10	15		0XWR1	15881-73432
C-10	16	2930-01-445-6361	0XWR1	19883-7303-0
C-10	17		0XWR1	15841-91510
C-10	18	4730-01-478-7119	0XWR1	09318-89030
C-10	19	4720-01-478-7185	0XWR1	15881-72870
C-10	20		0XWR1	16889-72860
C-10	21		0XWR1	16899-72860
C-10	22		0XWR1	02751-50060
C-10	23	4720-01-478-6494	97403	13230E6331
C-10	23		29381	5242003A
C-10	24	5306-01-479-0332	0XWR1	01203-50638
C-11	1		0XWR1	01123-50825
C-11	2		0XWR1	04015-60080
C-11	3		0XWR1	01023-50616
C-11	4		0XWR1	19883-64420
C-11	4A	5305-01-479-1846	97403	13218E0493-1287PIIC
C-11	4B		97403	13230E6744-41
C-11	4C		30554	88-20564-17
C-11	4D		97403	13230E6232-38
C-11	4E	5940-00-113-8184	97403	13217E3854-4
C-11	4F		97403	13230E6653-5-3INCH
C-11	4G		98410	BB-837-06
C-11	5	6685-01-442-2395	59197	323-421
C-11	6	2990-01-478-6492	97403	13230E6320
C-11	7		0XWR1	19883-64010
C-11	8		97403	13230E6336
C-11	9		0XWR1	02176-50100
C-11	10		0XWR1	04512-60100
C-11	11		0XWR1	04011-50100
C-11	12	5365-01-485-9244	0XWR1	19837-64372
C-11	13	5930-01-391-8105	0XWR1	15841-39010
C-11	13A		0XWR1	04013-60100
C-11	14		0XWR1	01173-51090
C-11	15	5310-01-440-6749	0XWR1	02761-50040
C-11	16		0XWR1	16861-65560
C-11	17	5310-01-478-5116	0XWR1	04013-60040
C-11	18	2920-01-478-7511	0XWR1	16881-65512
C-11	19	2920-01-479-1725	97403	13230E6339
C-11	20	5306-01-479-0338	0XWR1	01153-50828
C-11	21	2310-14-497-4269	0XWR1	19883-63010
C-11	22		0XWR1	04512-60080
C-11	23		0XWR1	02114-50080
C-12	1		30554	88-20579-4-20INCH
C-12	2		30554	88-20579-4-15INCH

FIGURE AND ITEM NUMBER INDEX

FIG.	ITEM	STOCK NUMBER	CAGEC	PART NUMBER
C-12	3	4730-01-470-1626	30554	88-20561-1
C-12	3		29381	1741005A
C-12	4		30554	88-20579-2-20INCH
C-12	5		67271	322135
C-12	6		67271	322136
C-12	7	2590-01-438-8872	67271	322026
C-12	8		0XWR1	16861-53732
C-12	9		0XWR1	16851-53722
C-12	10		0XWR1	16851-53712
C-12	11		0XWR1	15862-42502
C-12	12		0XWR1	16001-53000
C-12	13		0XWR1	15841-53622
C-12	14		30554	88-20579-2-7INCH
C-12	15	2910-01-439-4915	67271	322123
C-12	16		0XWR1	15601-96650
C-12	17	5310-01-478-5173	0XWR1	15841-92320
C-12	18		0XWR1	04512-60060
C-12	19	2915-01-494-3004	0XWR1	16006-51010
C-12	20	5365-01-437-1065	0XWR1	16006-52092
C-12	21	5365-01-437-1064	0XWR1	16006-52112
C-12	21A		0XWR1	16006-52122
C-12	22	5307-01-477-2256	1Q0C4	15841-91500
C-12	23		30554	88-20579-4-7.5INCH
C-12	24	2910-01-478-8822	0XWR1	19204-43010
C-12	25		0XWR1	01023-50616
C-12	26		0XWR1	19035-52030
C-12	27	5330-01-478-6366	0XWR1	16264-52140
C-12	28		30554	88-20579-4-6INCH
C-12	29	5306-01-479-0350	0XWR1	01311-10620
C-12	30	4730-01-486-3468	0XWR1	15841-95680
C-13	1	5305-01-480-1127	0XWR1	15841-51350
C-13	2	5330-01-478-4851	0XWR1	15841-96650
C-13	3	4730-01-486-3490	0XWR1	15841-51320
C-13	4	5330-01-478-4849	0XWR1	15841-96660
C-14	1		0XWR1	19204-43280
C-14	2	5331-01-325-5809	31013	04810-00060
C-14	3	5305-01-320-7069	S4532	14301-4383-0
C-14	4	5331-01-320-9567	S4532	04811-00390
C-14	5		0XWR1	14301-43570
C-14	6	2940-01-478-9487	0XWR1	15231-43560
C-14	7		0XWR1	15393-43580
C-14	8		0XWR1	14301-43590
C-14	9		0XWR1	14301-43522
C-14	10	5331-01-320-9566	0XWR1	14301-43840

FIGURE AND ITEM NUMBER INDEX

FIG.	ITEM	STOCK NUMBER	CAGEC	PART NUMBER
C-14	11		0XWR1	14301-43820
C-15	1		0XWR1	15841-13540
C-15	2		0XWR1	15841-13560
C-15	3		0XWR1	15841-96020
C-15	4		0XWR1	15321-96260
C-15	5		0XWR1	15261-03370
C-15	6		0XWR1	15261-96010
C-16	1	3120-01-478-6138	0XWR1	16851-21980
C-16	2	5306-01-479-0361	0XWR1	16851-22140
C-16	3	3120-01-478-6132	0XWR1	15861-22980
C-16	3	3120-01-478-6135	0XWR1	15861-22970
C-16	3	3120-01-478-6137	0XWR1	16851-22320
C-17	1		97403	13230E6305
C-17	1		29381	3127008A
C-17	2	4730-00-595-1721	93061	125HBL-5-4
C-17	2		93061	125HBL-5-4
C-17	3		77060	12015323
C-17	4	5999-01-406-4110	77060	12124582
C-17	4		77060	12089188
C-17	5	5935-01-214-4163	22785	12010973
C-17	5	5935-01-214-5259	77060	12015792
C-17	6		29381	2219012A-6
C-18	1		97403	13230E6283
C-18	2		97403	13230E6288-1
C-18	3	5320-00-754-0992	97403	13230E6685-AD6-7
C-18	3		29381	1710006A
C-18	4	5310-01-273-4535	80205	MS15795-848
C-18	4		30554	88-20033-11C
C-18	5		97403	13230E6288-2
C-18	5		97403	13230E6288-3
C-18	6		29381	1224201A
C-18	7		29381	1434011A
C-18	8		30554	69-561-6
C-18	9		29381	1611038A
C-19	1		77060	12015323
C-19	2		97403	13230E6240-1
C-19	3		77060	12015792
C-19	4		05624	DYNT17200
C-20	1		98410	BB-837-10
C-20	1		96906	MS25036-103
C-20	2	5940-01-082-3321	00779	3-350820-2
C-20	2		14726	S05300F
C-20	3		30554	88-20018-3
C-20	4	5935-01-110-1942	96906	MS3452W24-28P

FIGURE AND ITEM NUMBER INDEX

FIG.	ITEM	STOCK NUMBER	CAGEC	PART NUMBER
C-20	4		29381	2160002
C-20	5	5940-00-143-4774	97403	13226E0107-12
C-20	6		97403	13230E6236-2
C-20	7		29381	2219026A
C-21	1	5935-01-478-5219	96906	MS3408DJ28D-11S
C-21	2	5940-00-204-8990	97403	13226E0107-18
C-21	3		77060	12015323
C-21	4	5935-01-478-6077	97403	13230E6306
C-21	5		77060	12124582
C-21	6	5940-00-143-4777	81343	MS25036-157
C-21	7		00779	3-350820-2
C-21	8	5940-01-478-6081	97403	13230E6237-4
C-21	9		96906	MS25036-113
C-21	10		22785	12010973
C-21	11	5935-01-336-5396	77060	1201 0974
C-21	12	5999-01-422-9740	19207	12420936
C-21	13	5935-01-292-2336	77060	12015793
C-21	14	5935-01-291-2814	10988	L124720
C-21	15		29381	2160004A
C-21	16		29381	2111001A
C-21	17		29381	2160005A
C-21	18		29381	2126006A
C-21	19		14726	S05300F
C-21	20		29381	2112003A
C-21	21		29381	2126002A
C-21	22		77060	12015792
C-22	1	5940-01-082-3321	00779	3-350820-2
C-22	2		81495	442-6474
C-22	3		56501	A-250
C-22	4	5940-01-478-6072	97403	13230E6236-3
C-22	5		97403	13230E6236-2
C-22	6		97403	13226E0107-23
C-22	7	5935-01-226-8367	96906	MS3452W28-11P
C-22	8		98410	BB-837-10
C-22	9		30554	88-20018-3
C-22	10		14726	S05300F
C-22	11		97403	13230E6236-2
C-22	12		29381	2160003A
C-22	13		96906	MS25036-103
C-23	1	5935-01-336-6409	77060	1201 0717
C-23	2		97403	13230E6241-3
C-23	3		77060	12015323
C-23	4		97403	13230E6250
C-23	5	5935-01-338-3532	64678	1201 0996

FIGURE AND ITEM NUMBER INDEX

FIG.	ITEM	STOCK NUMBER	CAGEC	PART NUMBER
C-23	6		22785	12010973
C-23	7	5940-00-143-4771	81343	MS25036-103
C-23	8		14726	S05300F
C-24	1		4X687	122-N6000
C-24	2		4X687	130-20799
C-24	3		4X687	003-25158
C-24	4		4X687	030-02813-1METER
C-24	5		4X687	015-41607
C-24	6		4X687	028-31507
C-24	7		4X687	130-20123
C-24	8		4X687	016-40716
C-24	9		4X687	029-63002
C-24	10		4X687	005-04076
C-24	11		4X687	130-20661
C-24	12		4X687	130-20667
C-24	13		4X687	130-1379
C-24	14	5331-01-479-0530	4X687	051-21792
C-24	15	3110-01-486-4864	4X687	051-01058
C-24	16		4X687	130-1384
C-24	17		4X687	122-NR01S571221
C-24	18		4X687	130-20930
C-24	19		4X687	016-40817
C-24	20		4X687	028-31508
C-24	21		4X687	130-20800
C-24	22		4X687	028-31506
C-24	23		4X687	029-63006
C-24	24		4X687	130-21297
C-24	25		97403	ASSEMBLY-1
C-24	26		4X687	130-21325
C-24	27		4X687	130-21020
C-24	28		4X687	016-40717
C-24	29		4X687	130-20761
C-24	30		4X687	130-21017
C-24	31		4X687	024-70618
C-25	1		4X687	130-1413
C-25	2	5961-01-486-1969	4X687	073-50032
C-25	3		4X687	130-1414
C-25	4	5961-01-486-1973	4X687	073-50033
C-25	5		4X687	001-08104
C-25	6		4X687	028-31506
C-25	7		4X687	029-63002
C-25	8		4X687	073-08063
C-25	9		4X687	130-20602
C-26	1	5935-01-095-4657	96906	MS3406DJ24A28S

FIGURE AND ITEM NUMBER INDEX

FIG.	ITEM	STOCK NUMBER	CAGEC	PART NUMBER
C-26	1		97403	13230E6650-2
C-26	2		97403	13230E6888-132
C-26	2		97403	13230E6888-60
C-26	3		29381	2160001
C-26	4		97403	13230E6888-120
C-26	5		29381	2219002A-8
C-27	1		97403	13230E6221
C-27	1		29381	4210004D
C-27	2	5310-01-478-6346	30554	88-20033-19C
C-27	3		97403	13230E6744-139
C-27	4	5310-00-400-5503	96906	MS35650-3254
C-27	5		97403	13230E6245-4
C-27	5		29381	1531011A
C-27	6		29381	1224201A
C-27	6		78553	C7931-1032-3B
C-27	7	5310-00-934-9761	96906	MS35649-264
C-27	8	5310-00-929-6395	80205	MS35338-136
C-27	9		30554	88-20033-5C
C-27	10	5305-01-479-1843	97403	13218E0493-2770PIIC
C-27	10		29381	1434011A
C-27	11	5305-01-479-1845	97403	13218E0493-1289PIIC
C-27	12	6645-01-369-2478	74400	85000
C-27	13	6625-01-478-5172	97403	13230E6224
C-27	14	6625-01-478-5163	97403	13230E6223
C-27	15	6625-01-478-5158	97403	13230E6222
C-27	16	5355-01-478-8487	97403	13230E6678-3
C-27	16A		29381	9830005A
C-27	17	5905-01-087-1910	18876	P12934-010-01
C-27	17		29381	2372002A
C-27	18	5930-00-540-8311	96906	MS27735-23
C-27	18		29381	2351003A
C-27	19	5930-01-478-5114	97403	13230E6278
C-27	19		29381	2351004A
C-27	20	5930-01-478-5110	97403	13230E6255
C-27	21	5930-00-539-7013	81349	M5423/02-01
C-27	22	6685-01-486-1376	97403	13230E6244
C-27	23	5905-01-478-8109	97403	13230E6233
C-27	24	6625-01-478-5168	97403	13230E6225
C-27	25	5930-00-615-6731	96906	MS25224-1
C-27	26	5930-01-155-0768	51917	9001KR9RH8
C-27	26A		96906	MS27735-23
C-27	26A		96906	MS27735-23
C-27	27	6210-01-478-6973	97403	13230E6229
C-27	28	5940-00-557-1629	97403	13217E3854-1

FIGURE AND ITEM NUMBER INDEX

FIG.	ITEM	STOCK NUMBER	CAGEC	PART NUMBER
C-27	29		97403	13230E6227
C-27	29		29381	4210005C
C-27	30		97403	13230E6235
C-27	30		29381	2233009D
C-27	31		29381	1454007A
C-27	31		97403	13218E0493-1287PIIC
C-27	32	5305-01-479-0551	30554	88-20042-57A
C-27	32		29381	1424011A
C-27	33		29381	1315001A
C-27	33		30554	88-20033-11B
C-27	34		97403	13230E6744-100
C-27	34		29381	1332100A
C-27	35		97403	13218E0320-129
C-27	36		97403	13230E6683-7
C-27	36A		29381	1224017A
C-27	37		30554	69-651-3
C-27	38		97403	13230E6232-14
C-27	38A		97403	13230E6232-9
C-27	38B		97403	13230E6232-13
C-27	38C		97403	13230E6232-12
C-27	38D		97403	13230E6232-10
C-27	38E		97403	13230E6232-8
C-27	39		97403	13230E6653-4-11INCH
C-27	39A		97403	13230E6653-4-11INCH
C-27	39B		97403	13230E6653-4-11INCH
C-27	39C		97403	13230E6653-4-11INCH
C-27	39D		97403	13230E6653-4-6INCH
C-27	39E		97403	13230E6653-4-2INCH
C-27	40		97403	13230E6232-7
C-27	41		97403	13230E6653-4-4INCH
C-27	42		96906	MS25036-103
C-27	43		29381	2231009B
C-27	44		97403	13230E6653-4-5.25INCH
C-27	45		96906	MS25036-103
C-27	46		97403	13230E6232-6
C-27	47		97403	13230E6653-4-4.5INCH
C-27	48		14726	S05300F
C-27	49		29381	2231010D
C-27	50		97403	13230E6653-4-18INCH
C-27	51		14726	S05300F
C-27	52		97403	13230E6232-3
C-27	52		29381	2231007C
C-27	53		96906	MS25036-103
C-27	53		96906	MS25036-103

FIGURE AND ITEM NUMBER INDEX

FIG.	ITEM	STOCK NUMBER	CAGEC	PART NUMBER
C-27	54		97403	13230E6653-4-6INCH
C-27	54		97403	13230E6653-4-6INCH
C-27	55		14726	S05300F
C-27	55		14726	S05300F
C-27	56		97403	13230E6232-4
C-27	56		29381	2231008C
C-27	57		96906	MS25036-103
C-27	57		96906	MS25036-103
C-27	58		97403	13230E6653-4-7INCH
C-27	58		97403	13230E6653-4-8.5INCH
C-27	59		14726	S05300F
C-27	59		14726	S05300F
C-27	60		97403	13230E6232-5
C-27	60		29381	2231006C
C-27	61		97403	13230E6653-4-6.75INCH
C-27	61		97403	13230E6653-4-8INCH
C-27	62		14726	S05300F
C-27	62		14726	S05300F
C-27	63		97403	13230E6232-1
C-27	63		29381	2231005D
C-27	64		96906	MS25036-103
C-27	64		29381	2111008A
C-27	65		97403	13230E6653-4-7.25INCH
C-27	65		97403	13230E6653-4-8INCH
C-27	66		97403	13217E3854-4
C-27	67		97403	13230E6232-2
C-27	68		97403	13217E3854-4
C-27	69		97403	13230E6653-4-8INCH
C-27	70		29381	2231040A
C-27	71		96906	MS25036-103
C-27	72		97403	13230E6653-4-7.25INCH
C-27	73		29381	2219026A
C-27	74		29381	2111008A
C-27	75		97403	13230E6232-11Z
C-27	76		97403	13230E6653-4-15.5INCH
C-27	77		97403	13217E3854-1
C-28	1		97403	13226E0107-12
C-28	2		98410	BB-837-10
C-28	3	5940-00-230-0515	97403	13226E0107-14
C-28	4		00779	3-350820-2
C-28	5		96906	MS3452W24-28P
C-28	6		30554	88-20018-3
C-28	7		96906	MS25036-103
C-28	8		29381	2111008A

FIGURE AND ITEM NUMBER INDEX

FIG.	ITEM	STOCK NUMBER	CAGEC	PART NUMBER
C-28	9		14726	S05300F
C-28	10		29381	2160002
C-29	1	5120-01-479-5832	0XWR1	07909-31661
C-29	2		0XWR1	07909-33102
C-29	3	5120-01-486-5065	0XWR1	07916-09032
C-29	4		0XWR1	07916-32011
C-29	5	6685-01-486-0361	0XWR1	07916-32032
C-29	6		0XWR1	07916-34041
C-29	7	5110-01-492-8462	0XWR1	KTST10030A
C-29	8		0XWR1	KTST10060-G
C-29	9	4910-00-728-8227	33287	J24460-01
C-29	10		0XWR1	KTST20010
C-29	11		0XWR1	KTST20020
C-29	12		0XWR1	KTST10060-E
BULK	1		98441	208-3
BULK	2		30554	88-20579-4
BULK	3		81346	ASTMA582
BULK	4		4X687	030-02813
BULK	5		97403	13230E6292-2
BULK	6		70485	X-1054
BULK	7		98441	243001-10-0380
BULK	8		29381	4732020A
BULK	9		29381	1513006A-20
BULK	10		97403	13230E6820-1
BULK	11		97403	13230E6888
BULK	12		29381	4722253
BULK	13		97403	13230E6653-4
BULK	14		97403	13230E6653-5
BULK	15		97403	13230E6653-7
BULK	16		97403	13230E6653-8
BULK	17		81349	M3AA414BC1
BULK	18		97403	13230E6820-3
BULK	19		97403	13230E6820-4

Cross Reference Indexes

Part Number Index

Part Number	FIG.	Item
001-08104	C-25	5
003-25158	C-24	3
005-04076	C-24	10
01023-50610	C-8	40
01023-50612	C-8	112
	C-9	5
01023-50614	C-8	120
01023-50616	C-11	3
	C-12	25
	C-10	6
01023-50618	C-8	64
01023-50620	C-8	149
	C-9	18
01023-50622	C-8	145
	C-10	2A
01023-50635	C-8	101
01023-50660	C-8	88F
01023-50675	C-8	78
01023-50680	C-8	88C
01023-60645	C-8	65
01023-60650	C-8	82A
	C-8	88E
01023-60670	C-8	88
01053-50618	C-8	92
01123-50825	C-11	1
01123-50828	C-8	52
01123-60814	C-9	4
01123-60816	C-8	35
	C-8	147B
01153-50828	C-11	20
01173-51090	C-11	14
01203-50638	C-10	24
01311-10620	C-12	29
01311-10828	C-8	54
015-41607	C-24	5
01513-50618	C-8	62
01513-50828	C-8	55
01513-60820	C-8	57
016-40716	C-24	8
016-40717	C-24	28
016-40817	C-24	19
01754-50610	C-10	12
01759-50616	C-8	60
02056-50060	C-8	21
02114-50080	C-8	13
	C-11	23
02156-50080	C-8	55A
02176-50100	C-11	9
024-70618	C-24	31
02751-50060	C-10	22
02756-50060	C-8	59
02761-50040	C-11	15
02783-50100	C-9	13
028-31506	C-24	22
	C-25	6
028-31507	C-24	6
028-31508	C-24	20

Section IV.

Cross Reference Indexes

Part Number Index

Part Number	FIG.	Item
029-63002	C-24	9
	C-25	7
029-63006	C-24	23
030-02813	BULK	4
030-02813-1METER	C-24	4
04011-50100	C-11	11
04012-50060	C-8	23
04013-60040	C-11	17
04013-60080	C-8	14
04013-60100	C-11	13A
04015-60080	C-11	2
04512-60060	C-8	22
	C-12	18
04512-60080	C-8	53
	C-11	22
04512-60100	C-11	10
04612-00170	C-8	115
04724-00140	C-8	70
04810-00060	C-14	2
04811-00100	C-14	5
04811-00390	C-14	4
04811-06130	C-8	73
04811-06230	C-8	85
04811-10070	C-8	95
04811-10160	C-8	108
04811-16220	C-8	126
04811-50300	C-8	10
04814-50600	C-9	35
05012-00508	C-8	155
05012-00814	C-8	160
051-01058	C-24	15
051-21792	C-24	14
05411-00318	C-8	111
05411-00420	C-8	26
05712-00408	C-9	11
073-08063	C-25	8
073-50032	C-25	2
073-50033	C-25	4
07715-03211	C-8	75
07909-30202-E	C-29	12
07909-31661	C-29	1
07909-33102	C-29	2
07916-09032	C-29	3
07916-32011	C-29	4
07916-32032	C-29	5
07916-34041	C-29	6
08103-06203	C-8	114
09318-88180	C-9	19A
09318-88200	C-9	19
09318-89030	C-10	18
1-2CD45B	C-6	7
10230	C-2	88
111K1139	C-23	11
1131001A	C-4	14
1131002A	C-2	1
1132002A	C-2	22
1132006A	C-2	72

Cross Reference Indexes

Part Number Index

Part Number	FIG.	Item
1133003A	C-2	94
11420-13150	C-8	31
1142001A	C-2	59
1142004A	C-7	9
1142007A	C-7	2
1143002A	C-2	55
	C-2	126
	C-7	7
1143004A	C-2	37
1143006A	C-2	122A
1201 0717	C-23	1
1201 0974	C-21	11
1201 0996	C-23	5
12010973	C-17	5
	C-21	10
	C-23	6
120145	C-18	9
12015323	C-6	3
	C-17	3
	C-19	1
	C-21	3
	C-22	17
	C-23	3
12015792	C-17	5
	C-19	3
	C-21	22
12015793	C-21	13
	C-22	12
1208 9188	C-6	4
	C-17	4
	C-19	2
1211009A	C-2	124B
12124582	C-17	4
	C-21	5
	C-21	23
122-N6000	C-24	1
122-NR01S571221	C-24	17
1224001A	C-2	144A
1224011A	C-2	114A
1224012A	C-2	50
	C-2	112H
1224015A	C-2	155
1224017A	C-2	151
	C-2	157
	C-27	36A
1224201A	C-2	104
	C-2	121A
	C-18	6
	C-27	6
12325823	C-6	7
12420936	C-21	12
	C-22	16
125HBL-5-4	C-17	2
	C-17	12
130-1379	C-24	13
130-1384	C-24	16
130-1413	C-25	1
130-1414	C-25	3

Cross Reference Indexes

Part Number Index

Part Number	FIG.	Item
130-20123	C-24	7
130-20602	C-25	9
130-20661	C-24	11
130-20667	C-24	12
130-20761	C-24	29
130-20799	C-24	2
130-20800	C-24	21
130-20930	C-24	18
130-21017	C-24	30
130-21020	C-24	27
130-21297	C-24	24
130-21325	C-24	26
1313004A	C-2	79
	C-2	103
1313006A	C-2	2
1313008A	C-2	19
1314004A	C-2	38
1315001A	C-27	33
1321008A	C-2	124A
13214E3789-2	C-2	119B
13217E3854-5	C-2	216
	C-2	226
	C-2	230
13217E7108-17	C-5	1
	C-6	8
13217E7108-5	C-5	4
	C-6	6
13218E0320-129	C-2	114
	C-27	35
13218E0320-248	C-2	157
13218E0320-291	C-2	123C
13218E0320-293	C-2	71
13218E0320-333	C-2	139
13218E0320-89	C-2	76
13218E0493-1287PIIC	C-11	4A
	C-27	31
13218E0493-1289PIIC	C-27	11
13218E0493-1810PIIC	C-2	48
13218E0493-2765PIIC	C-4	21
13218E0493-2770PIIC	C-27	10
13218E0493-289PIIC	C-2	163
13218E0493-345PIIC	C-2	149
13218E0493-349PIIC	C-2	147
13218E0493-350PIIC	C-2	147
13218E0493-354PIIC	C-2	148
13226E0107-14	C-28	3
13226E0107-18	C-21	2
13226E0107-5	C-2	122D
13226E8549	C-2	118B
1323006A	C-4	15
1323007A	C-2	18
	C-2	72A
13230E6219	C-2	119A
13230E6220	C-1	1
13230E6221	C-27	1
13230E6222	C-27	15
13230E6223	C-27	14
13230E6224	C-27	13

Cross Reference Indexes

Part Number Index

Part Number	FIG.	Item
13230E6225	C-27	24
13230E6227	C-27	29
13230E6229	C-27	27
13230E6231-4	C-2	155A
13230E6232-1	C-27	63
13230E6232-10	C-27	38D
13230E6232-11Z	C-27	75
13230E6232-12	C-27	38C
13230E6232-13	C-27	38B
13230E6232-14	C-27	38
13230E6232-15	C-2	192
13230E6232-16	C-2	168
13230E6232-17	C-2	176
13230E6232-18	C-2	199
13230E6232-19	C-2	170
13230E6232-2	C-27	67
13230E6232-20	C-2	173
13230E6232-21	C-2	195
13230E6232-22	C-2	202
13230E6232-23	C-2	206
13230E6232-24	C-2	217
13230E6232-25	C-2	252
13230E6232-26	C-2	233
13230E6232-27	C-2	237
13230E6232-28	C-2	210
13230E6232-29	C-2	213
13230E6232-3	C-27	52
13230E6232-30	C-2	225
13230E6232-31	C-2	229
13230E6232-32	C-2	248
13230E6232-33	C-2	221
13230E6232-34	C-2	168A
13230E6232-35	C-2	168B
13230E6232-36	C-2	168C
13230E6232-37ZZ	C-2	240
13230E6232-38	C-11	4D
13230E6232-4	C-27	56
13230E6232-5	C-27	60
13230E6232-6	C-27	46
13230E6232-7	C-27	40
13230E6232-8	C-27	38E
13230E6232-9	C-27	38A
13230E6233	C-27	23
13230E6235	C-27	30
13230E6236-2	C-2	188
	C-2	259
	C-20	6
	C-22	5
	C-22	11
13230E6236-3	C-22	4
13230E6240-1	C-5	7
	C-19	2
13230E6241-3	C-23	2
13230E6242-6	C-5	6
13230E6244	C-27	22
13230E6245-4	C-27	5
13230E6248	C-2	160

Cross Reference Indexes

Part Number Index

Part Number	FIG.	Item
13230E6249	C-2	159
13230E6250	C-23	4
13230E6251	C-2	118
13230E6252	C-2	158
13230E6253	C-2	132
13230E6254	C-2	130
13230E6255	C-27	20
13230E6256	C-2	143
13230E6258	C-2	162
13230E6259	C-2	187
13230E6260	C-2	122
13230E6261	C-2	165
13230E6262	C-2	134
13230E6263	C-2	146
13230E6264	C-2	166
13230E6265	C-2	152
13230E6266	C-2	145
13230E6267	C-2	138
13230E6268	C-2	119
13230E6269	C-2	121
13230E6270	C-2	128
13230E6271	C-2	112F
13230E6272	C-2	120
13230E6273	C-2	112G
13230E6274-1	C-2	113
	C-2	135
13230E6275	C-2	142
13230E6276	C-2	144
13230E6278	C-27	19
13230E6279	C-2	167
13230E6282	C-2	89
13230E6283	C-18	1
13230E6286	C-2	106
13230E6287	C-2	85
13230E6288-1	C-18	2
13230E6288-2	C-18	5
13230E6288-3	C-18	5
13230E6289	C-2	84
13230E6290	C-2	86
13230E6291	C-2	105
13230E6292-1-46INCH	C-2	83
13230E6292-2	BULK	5
13230E6292-2-11INCH	C-3	4
13230E6293	C-3	3
13230E6294	C-2	82
13230E6295	C-2	112C
13230E6297	C-2	20
13230E6298	C-5	3
13230E6299	C-2	100
13230E6300	C-1	3
13230E6300 ITEM 209	C-2	70
13230E6301	C-3	1
13230E6302	C-2	164
13230E6303	C-7	1
13230E6305	C-17	1
13230E6306	C-21	4

Cross Reference Indexes

Part Number Index

Part Number	FIG.	Item
13230E6307	C-7	4
13230E6308	C-1	2
13230E6310	C-2	68
13230E6312	C-2	129
13230E6314	C-2	39
13230E6315	C-2	33
13230E6316	C-2	66
13230E6317	C-2	64
13230E6318	C-2	31
13230E6320	C-11	6
13230E6322	C-7	6
13230E6323	C-7	5
13230E6324	C-2	42
13230E6326	C-2	93
13230E6327	C-2	65
13230E6328	C-2	44
13230E6329	C-2	45
13230E6330	C-10	1
13230E6331	C-10	23
13230E6332	C-2	123
13230E6333	C-2	43
13230E6334	C-2	49
13230E6335	C-2	70
13230E6336	C-11	8
13230E6337	C-2	16
13230E6339	C-11	19
13230E6340	C-2	26
13230E6342	C-2	108
13230E6343	C-2	111
13230E6344	C-2	112
13230E6345	C-2	78
13230E6346	C-2	77
13230E6347	C-2	74
13230E6644-1	C-2	75
13230E6645	C-2	73
13230E6646	C-4	13
13230E6647	C-4	17
13230E6648	C-4	1
13230E6649	C-2	44A
13230E6650-2	C-26	1
13230E6652-2	C-22	12
13230E6653-4-11INCH	C-27	39
	C-27	39A
	C-27	39B
13230E6653-4-14INCH	C-2	169
13230E6653-4-15.5INCH	C-27	76
13230E6653-4-17INCH	C-2	212
13230E6653-4-18.5INCH	C-2	239
13230E6653-4-18INCH	C-22	19
	C-27	50
13230E6653-4-1INCH	C-27	39C
13230E6653-4-24INCH	C-2	190
	C-2	215
13230E6653-4-26.5INCH	C-2	250
13230E6653-4-26.62INCH	C-2	235
13230E6653-4-28INCH	C-2	254
13230E6653-4-2INCH	C-2	262

Cross Reference Indexes

Part Number Index

Part Number	FIG.	Item
	C-27	39E
13230E6653-4-30.5INCH	C-2	231
13230E6653-4-30INCH	C-2	227
13230E6653-4-32INCH	C-2	258
13230E6653-4-3INCH	C-2	242
13230E6653-4-4.5INCH	C-2	194
	C-27	47
13230E6653-4-46INCH	C-2	223
13230E6653-4-4INCH	C-27	41
13230E6653-4-5.25INCH	C-27	44
13230E6653-4-6.75INCH	C-27	61
13230E6653-4-6INCH	C-27	54
	C-27	39D
13230E6653-4-7.25INCH	C-27	65
	C-27	72
13230E6653-4-7INCH	C-27	58
13230E6653-4-8.5INCH	C-27	58
13230E6653-4-8INCH	C-27	61
	C-27	65
	C-27	69
13230E6653-5-217INCH	C-21	26
13230E6653-5-276INCH	C-22	14
13230E6653-5-3INCH	C-11	4F
13230E6653-5-84INCH	C-22	18
13230E6653-7-10INCH	C-2	197
13230E6653-7-14INCH	C-2	208
13230E6653-7-22INCH	C-2	200
13230E6653-7-24INCH	C-2	219
13230E6653-7-29INCH	C-2	245
13230E6653-7-66INCH	C-21	27
13230E6653-7-96INCH	C-22	15
13230E6653-8-15INCH	C-2	204
13230E6653-8-2.5INCH	C-2	169A
	C-2	169B
	C-2	169C
13230E6653-8-28INCH	C-2	178
	C-2	181
	C-2	185
13230E6653-8-6.5INCH	C-2	171
13230E6653-8-7.25INCH	C-2	174
13230E6669-5A	C-2	10
13230E6669-6A	C-2	10
13230E6670	C-6	1
13230E6671-365A	C-2	161
13230E6673-65A	C-3	2
13230E6673-66A	C-2	112I
13230E6673-83A	C-4	8
13230E6674-100A	C-2	112A
13230E6674-118A	C-2	17
13230E6674-138A	C-2	91
	C-2	94
13230E6674-139A	C-2	29
13230E6674-64A	C-2	101
	C-2	117A
13230E6674-66A	C-2	5
	C-2	11
	C-2	80
13230E6674-67A	C-2	80

Cross Reference Indexes

Part Number Index

Part Number	FIG.	Item
13230E6674-68A	C-2	51
13230E6674-74A	C-2	87
13230E6674-75A	C-2	81
13230E6674-76A	C-2	98
	C-2	110
13230E6674-96A	C-2	27
13230E6674-98A	C-2	1
	C-4	18
13230E6674-99A	C-2	123A
	C-4	14
13230E6678-3	C-27	16
13230E6680	C-6	2
13230E6681-4A	C-2	46A
13230E6685-AD6-7	C-18	3
13230E6688	C-2	62
13230E6743-39A	C-2	102
13230E6744-100	C-2	115
	C-27	34
13230E6744-103	C-2	141A
13230E6744-139	C-2	28
	C-27	3
13230E6744-140	C-2	18
13230E6744-41	C-11	4B
13230E6744-43	C-2	52
13230E6744-44	C-4	15
13230E6744-45	C-2	24
13230E6744-46	C-2	125
	C-2	141B
	C-4	26
13230E6744-59	C-2	150
13230E6791	C-2	54
13230E6792	C-2	61
13230E6812-1	C-2	166A
13230E6813	C-2	47
13230E6816	C-1	3
13230E6820-1	C-2	98
	BULK	10
13230E6820-3	C-2	96
	BULK	18
13230E6820-4	C-2	97
	BULK	19
13230E6821	C-2	99
13230E6846	C-2	89
13230E6847	C-1	2
13230E6848	C-4	23
13230E6866	C-4	4
13230E6867-2	C-2	106
13230E6868	C-2	129
13230E6869	C-4	24
13230E6870	C-4	19
13230E6871	C-4	20
13230E6872	C-4	25
13230E6873	C-2	112B
13230E6874	C-2	92
13230E6875	C-2	43A
	C-4	2
13230E6877	C-2	112D
13230E6878	C-2	95
13230E6879	C-4	5

Section IV.

ARMY TM 9-6115-670-14&P
Cross Reference Indexes
Part Number Index

Part Number	FIG.	Item
13230E6880	C-4	7
13230E6881-1	C-2	123D
13230E6881-2	C-2	123E
13230E6882	C-4	10
13230E6883-1	C-4	6
13230E6883-2	C-4	9
13230E6888	BULK	11
13230E6888-120	C-26	4
13230E6888-132	C-26	2
13230E6888-60	C-26	2
13230E6961	C-2	162A
13230E6962	C-2	162B
13230E6964	C-2	152
13230E6965	C-2	128
13230E6966	C-2	26
13230E6967	C-2	115B
13230E6968	C-2	166
13230E6969	C-2	119C
13230E6970	C-2	112
13230E6971	C-2	146
13230E6972-1	C-21	1A
13230E6973-19-120INCH	C-21	24
13230E6973-19-12INCH	C-17	8
13230E6973-26-12INCH	C-2	21B
13230E6973-31-6INCH	C-21	25
13230E6973-36-15INCH	C-23	10
13230E6974-2	C-21	1B
13230E6975	C-2	122
13230E6976	C-2	21
13230E6977	C-2	145
13230E6978	C-2	122C
13230E6979	C-2	122B
1324003A	C-2	60
	C-7	3
1324004A	C-2	40
	C-7	8
1324005A	C-2	36
1332100A	C-27	34
1332102A	C-2	112E
13811-33080	C-8	86
1423005A	C-2	149
1424011A	C-2	117
	C-27	32
14301-43522	C-14	9
14301-43590	C-14	8
14301-43820	C-14	11
14301-4383-0	C-14	3
14301-43840	C-14	10
1434011A	C-2	81
	C-2	120A
	C-18	7
	C-27	10
1452002A	C-2	113
1453041A	C-2	124
1454007A	C-2	148
	C-2	163
	C-27	31
1459027-7INCHES	C-2	9
14601-03450	C-8	38
14601-1311-0	C-8	33
14601-1312-0	C-8	32

Cross Reference Indexes

Part Number Index

Part Number	FIG.	Item
14601-1324-0	C-8	30
14601-13330	C-8	29
14601-1336-0	C-8	28
14601-14310	C-8	24
14601-14410	C-8	39
15108-57280	C-8	107
1513006A-20	BULK	9
15221-01750	C-8	36
15221-33650	C-8	169
15221-33700	C-8	168
15221-88210	C-8	83
15231-33960	C-8	164
15231-43560	C-14	6
15261-03370	C-15	5
15261-21330	C-8	131
15261-23530	C-8	144
15261-23540	C-8	142
15261-23950	C-8	144
15261-23960	C-8	144
15261-23970	C-8	142
15261-23980	C-8	142
15261-96010	C-8	162
	C-15	6
15261-96160	C-8	159
15263-12370	C-2	56
1531011A	C-27	5
15321-73340	C-8	167
15321-96260	C-15	4
15393-43580	C-14	7
15441-33520	C-9	19C
15451-96270	C-8	158
15451-96670	C-9	7
15471-96650	C-9	23
15521-96020	C-8	161
15521-96030	C-8	163
15601-96650	C-8	7
	C-12	16
15676-73270	C-10	3
15694-23930	C-8	143
15694-23940	C-8	143
15821-52030	C-12	26
15841-04540	C-8	136
15841-04562	C-8	138
15841-04810	C-8	150
15841-04822	C-8	151
15841-05140	C-8	18
15841-05150	C-8	20
15841-05370	C-8	17
15841-05510	C-8	12
15841-0567-0	C-8	19
15841-13540	C-15	1
15841-13560	C-15	2
15841-1403-0	C-8	44
15841-14320	C-8	42
15841-14350	C-8	45
15841-14620	C-8	8
15841-16320	C-8	113

Cross Reference Indexes

Part Number Index

Part Number	FIG.	Item
15841-23250	C-8	125
15841-2411-0	C-8	128
15841-35660	C-9	12
15841-3693-0	C-8	76
15841-39010	C-11	13
15841-51320	C-13	3
15841-51350	C-13	1
15841-53622	C-12	13
15841-54092	C-8	99
15841-54122	C-8	102
15841-56110	C-8	94
15841-56480	C-8	97
15841-57110	C-8	93
15841-57212	C-8	106
15841-57240	C-8	109
15841-57920	C-8	91
15841-72922	C-10	5
15841-7302-0	C-8	167
15841-73260	C-10	11
15841-74250	C-10	14
15841-91010	C-8	77
	C-8	88A
15841-91050	C-9	14
15841-91500	C-12	22
15841-91510	C-10	17
15841-92010	C-8	90
15841-92020	C-8	103
15841-92320	C-12	17
15841-92330	C-8	104
15841-94022	C-8	41
15841-95680	C-12	30
15841-96020	C-15	3
15841-96650	C-13	2
15841-96660	C-13	4
15846-33110	C-8	84
15852-04360	C-8	152
15852-25160	C-8	147
15852-33140	C-8	9
	C-8	88G
15861-11820	C-8	63
15861-14263	C-8	25
15861-22970	C-16	3
15861-22980	C-16	3
15861-23470	C-8	135
15861-23860	C-8	135
	C-8	139
15861-23870	C-8	135
	C-8	139
15861-23910	C-8	135
15861-23920	C-8	135
15862-04132	C-8	72
15862-11770	C-8	66
15862-12350	C-8	61
15862-42502	C-12	11
15875-24013	C-8	119
15875-24250	C-8	121
15875-24320	C-8	117

Cross Reference Indexes

Part Number Index

Part Number	FIG.	Item
15875-24370	C-8	118
15877-04140	C-8	82
15881-04026	C-8	71
15881-05550	C-8	11
15881-05590	C-8	15
15881-2331-0	C-8	127
15881-72870	C-10	19
15881-73432	C-10	15
15881-91030	C-8	80
15891-91020	C-10	7
16000-56050	C-8	100
16001-53000	C-12	12
16006-51010	C-12	19
16006-52092	C-12	20
16006-52112	C-12	21
16006-52122	C-12	21A
16241-11640	C-8	46
16241-11720	C-8	67
16241-11721	C-8	68
16241-33360	C-9	25
16241-37080	C-9	31
16241-37200	C-9	36
16241-54420	C-8	105
16241-72970	C-8	47
16241-72971	C-8	47
16241-73360	C-9	29
	C-10	8
16241-95800	C-9	22
16264-52140	C-12	27
16266-01620	C-9	9
16292-17110	C-8	50
16299-17100	C-8	56
16299-33670	C-9	16
16299-37010	C-9	34
16667-57150	C-8	110
16689-23480	C-8	143
16689-23490	C-8	139
16851-04040	C-8	137
16851-04092	C-8	141
16851-13280	C-8	27
16851-1511-0	C-8	122
16851-1555-0	C-8	123
16851-16212	C-8	157
16851-2111-2	C-8	129
16851-2131-0	C-8	133
16851-2190-0	C-8	129
16851-21980	C-16	1
16851-2201-0	C-8	132
16851-22140	C-16	2
16851-22320	C-16	3
16851-32110	C-9	2
16851-3501-0	C-9	15
16851-35152	C-9	10
16851-36410	C-9	1
16851-36950	C-8	74
16851-53712	C-12	10
16851-53722	C-12	9

Cross Reference Indexes

Part Number Index

Part Number	FIG.	Item
16851-73350	C-10	9
16851-96260	C-8	165
16851-96270	C-8	156
16853-21050	C-8	130
16853-21090	C-8	130
16861-04050	C-8	140
16861-14522	C-8	5
16861-16020	C-8	116
16861-23480	C-8	143
16861-23490	C-8	139
16861-25010	C-8	146
16861-53732	C-12	8
16861-65560	C-11	16
16861-93310	C-8	16
16862-14500	C-8	6
16863-01500	C-9	8
16863-2301-0	C-8	153
16864-16010	C-8	124
16871-03310	C-8	34
16871-14430	C-8	43
16873-03042	C-8	37
16873-72700	C-10	4
16875-74280	C-8	79
16878-57740	C-8	96
16881-01010	C-8	154
16881-03310	C-8	34
16881-04020	C-8	71
16881-04040	C-8	137
16881-04050	C-8	140
16881-04090	C-8	141
16881-11630	C-8	48
16881-11670	C-8	68
16881-11770	C-8	66
16881-12310	C-8	58
16881-12320	C-8	51
16881-17010	C-8	49
16881-21050	C-8	130
16881-21090	C-8	130
16881-21110	C-8	129
16881-21900	C-8	129
16881-23910	C-8	143
16881-23920	C-8	143
16881-23930	C-8	139
16881-23940	C-8	139
16881-33210	C-9	24
16881-33220	C-9	17
16881-33230	C-9	21
16881-33242	C-9	20
16881-33370	C-9	26
16881-37010	C-9	34
16881-37152	C-9	32
16881-37160	C-9	30
16881-37200	C-9	36
16881-65512	C-11	18
16881-96010	C-8	69
16881-96750	C-9	27
16889-72860	C-10	20

Cross Reference Indexes

Part Number Index

Part Number	FIG.	Item
	C-10	21
16899-01010	C-8	154
16899-37080	C-9	31
16899-37152	C-9	32
16899-37162	C-9	30
17331-59190	C-8	166
1741008A	C-10	2
1743102A	C-2	107
17563-91010	C-8	88B
1788880	C-5	8
	C-6	5
19090-11310	C-8	88H
191150079	C-21	8
19202-91010	C-7	9
19203-7301-0	C-10	10
19204-43010	C-12	24
19204-43280	C-14	1
19215-99160	C-8	148
19217-97010	C-8	81
19265-74110	C-10	13
19298-9602-0	C-10	4A
19461-56412	C-8	98
19461-88132	C-8	87
19483-33120	C-8	88J
19666-04620	C-8	147A
19805-72530	C-8	88D
19837-57720	C-8	89
19837-64372	C-11	12
19883-63010	C-11	21
19883-64010	C-11	7
19883-64420	C-11	4
19883-7303-0	C-10	16
2-2-140239CA	C-5	2
208-3	BULK	1
2111001A	C-2	184
	C-21	16
2111008A	C-27	64
	C-27	74
	C-28	8
2112003A	C-21	20
2113003A	C-2	261
2126002A	C-21	21
2126003A	C-6	4
2126006A	C-21	18
2160001A	C-26	3
2160002A	C-20	4
	C-28	10
2160003A	C-22	12
2160005A	C-21	17
2173002B	C-2	143
2219002A-8	C-26	5
2219012A-6	C-17	6
2219026A	C-20	7
	C-27	73
2219027A	C-2	246
2231005D	C-27	63
2231006C	C-27	60

Cross Reference Indexes

Part Number Index

Part Number	FIG.	Item
2231007C	C-27	52
2231008C	C-27	56
2231009B	C-27	43
2231010D	C-27	49
2231013D	C-2	256
2231023B	C-2	243
2231032A	C-2	260
2231038C	C-2	179
2231039D	C-2	183
2231040A	C-27	70
2233004E	C-2	162
2233005E	C-2	165
2233006E	C-2	122
2233007A	C-1	2
2233009D	C-27	30
2351002A	C-27	26A
2351003A	C-27	18
2351004A	C-27	19
2372002A	C-27	17
243001-10-0380	BULK	7
3-334-485-008	C-2	154
3-350820-2	C-20	2
	C-21	7
	C-22	1
	C-28	4
3111001Y	C-7	1
3112004E	C-2	42
3123006A	C-2	62
3123014A	C-2	54
3124030B	C-2	45
3125002B	C-2	89
3127008A	C-17	1
322026	C-12	7
322035	C-9	3
322084	C-9	6
322123	C-12	15
322135	C-12	5
322136	C-12	6
323-421	C-11	5
3234001A	C-2	12
33430-82760	C-9	19B
344-1013P7	C-2	32
39TB08F	C-27	36
4110034F	C-2	61
4130026B	C-2	123
4140013A	C-2	144B
4206-006	C-2	155B
4210004D	C-27	1
4210005C	C-27	29
4210008D	C-2	105
4210009C	C-2	86
4210013D	C-2	138
4210014D	C-2	145
4210020C	C-2	20
4210021C	C-2	129
4210023C	C-2	106
4210036C	C-2	152

Cross Reference Indexes

Part Number Index

Part Number	FIG.	Item
4210037B	C-2	166
4210038E	C-2	146
4210039A	C-2	128
4210040B	C-2	121
4210042B	C-2	85
4210044A	C-2	84
4210045A	C-2	82
4210061C	C-2	49
4210073A	C-2	134
4210229A	C-2	77
4210230A	C-2	73
4210231A	C-4	17
4210232A	C-4	13
4210261A	C-2	39
42282-2	C-22	3
4230002D	C-7	6
4230010E	C-2	16
4230022B	C-2	112G
4230092B	C-2	74
4230103A	C-2	6
4250005B	C-2	33
4250014C	C-2	31
4250078C	C-4	1
4250081A	C-2	108
4250082A	C-2	78
4320001A	C-2	112F
442 6474	C-2	198
	C-2	201
	C-2	218
	C-2	244
	C-22	2
4610002A	C-2	75
4722253	BULK	12
4732020A	BULK	8
4820045B	C-2	99
4820046B	C-2	44A
4821025A	C-2	112
4831002C	C-1	1
5241017A	C-2	70
52487	C-2	90
5SFT-251	C-2	133
6320	C-2	63
6340	C-12	3
67A7A5-1	C-2	131
69-561-3	C-2	155
	C-27	37
69-561-5	C-2	136
69-561-6	C-2	14
	C-2	76
	C-18	8
70000-15241	C-9	33
70097-10640	C-29	10
70097-10650	C-29	11
70097-45549	C-29	8
7032916-501	C-1	3
70646	C-10	23
76141	C-5	5

Cross Reference Indexes

Part Number Index

Part Number	FIG.	Item
85000	C-27	12
88-20033-11A	C-2	53
88-20033-11B	C-2	116
	C-27	33
88-20033-11C	C-2	79
	C-18	4
88-20033-19C	C-27	2
88-20033-20C	C-2	2
88-20033-26C	C-4	27
88-20033-30C	C-4	12
88-20033-33B	C-2	141
88-20033-33C	C-2	19
88-20033-5C	C-2	23
	C-2	72B
	C-27	9
88-20037WWDG8	C-2	107
88-20541-13	C-17	7
88-20546-8	C-2	123B
88-20561-1	C-12	3
88-20561-2	C-10	2
88-20561-3	C-2	46
88-20564-17	C-11	4C
88-20568-1	C-2	3
88-20579-2-20 INCH	C-12	4
88-20579-2-7 INCH	C-12	14
88-20579-4	BULK	2
88-20579-4-15 INCH	C-12	2
88-20579-4-20 INCH	C-12	1
88-20579-4-6 INCH	C-12	28
88-20579-4-7.5 INCH	C-12	23
88-21674-4	C-2	137
8820042-57A	C-27	32
9001KR9RH8	C-27	26
9830005A	C-27	16A
A-250	C-2	189
	C-2	193
	C-2	236
	C-2	255
	C-22	3
AA572406-3-SB	C-2	67
AKKH175	C-2	7
ASSEMBLY-1	C-24	25
ASTMA484	BULK	3
ASTMA582-1 INCH	C-2	13
B18212HRCZ080	C-2	40
	C-7	8
B18212HRCZ100	C-2	36
B1821BH031C100N	C-2	17
B1821BH031C125N	C-2	22
B1821BH038C075N	C-2	127
B1821BH038C088N	C-2	126
B1821BH038C200N	C-2	123F
B1821BH038C250N	C-2	123G
B1821BH38C100N	C-4	11
B1822BS080R	C-2	38
B18235B06010N	C-2	59
B18235B06050N	C-7	2

Cross Reference Indexes

Part Number Index

Part Number	FIG.	Item
B18235B08016N	C-2	48
B18235B08020-1	C-7	7
B18235B08020N	C-2	55
B18235B08070N	C-2	37
B18241B080	C-2	41
BB-837-06	C-11	4G
BYRF2516	C-2	5
C2060T6	C-2	34
C7931-1024-3B	C-2	104
C7931-1032-3B	C-27	6
C7941-1024-3B	C-2	91
DIN912M10X35-8-8	C-2	43B
	C-4	3
DYNC-10502-000-0-24	C-2	21
	C-2	21A
DYNK218-2	C-2	6
DYNK31-006	C-2	9
DYNT17200	C-19	4
DYRF29	C-2	8
FSP3X9	C-2	57
HF3G	C-2	12
ISO8676-M10X1.25X20-8.8	C-2	109
ISO8676-M10X1.25X25-8.8	C-2	35
	C-2	58
J24460-01	C-29	9
KTST10030A	C-29	7
L124720	C-21	14
LS12906-87	C-2	117
M22759/16-10-9	BULK	16
M22759/16-12-9	BULK	15
M22759/16-16-9	BULK	14
M24243/1-B404	C-2	144C
M24243/1-B604	C-18	3
M3AA414BC1	BULK	17
M5423/02-01	C-27	21
MNG10-8RX	C-21	30
MS15795-848	C-18	4
MS21044C3	C-4	22
MS25036-103	C-23	7
	C-2	191
	C-2	222
	C-2	249
	C-19	5
	C-20	1
	C-22	13
	C-27	42
	C-27	45
	C-27	53
	C-27	57
	C-27	64
	C-27	71
	C-28	7
MS25036-105	C-17	10
MS25036-108	C-20	1
	C-21	29
	C-22	8
	C-28	2

Cross Reference Indexes

Part Number Index

Part Number	FIG.	Item
MS25036-110	C-17	11
MS25036-111	C-21	2
MS25036-112	C-2	209
MS25036-113	C-2	180
	C-2	186
	C-2	205
	C-21	9
MS25036-114	C-2	172
	C-2	175
	C-2	177
	C-2	182
	C-2	196
	C-2	203
	C-2	207
	C-2	220
	C-2	247
	C-22	6
MS25036-149	C-27	28
MS25036-150	C-2	122E
	C-11	4E
	C-27	66
	C-27	68
MS25036-153	C-20	5
	C-28	1
MS25036-157	C-21	6
MS25224-1	C-27	25
MS27130-S27	C-23	9
MS27183-10	C-4	16
MS27735-23	C-27	18
	C-27	26A
MS3108R28-11S	C-21	15
MS3367-5-9	C-2	21C
	C-20	3
	C-21	28
	C-22	9
	C-28	6
MS3406DJ24A28S	C-26	1
MS3408DJ28D-11S	C-21	1
MS3452W24-28P	C-20	4
	C-28	5
MS3452W28-11P	C-22	7
MS35333-110	C-2	140
MS35338-136	C-27	8
MS35338-138	C-2	76A
MS35338-141	C-2	30
MS35338-43	C-2	15
MS35489-23	C-2	156
MS35649-242	C-2	151
MS35649-264	C-27	7
MS35650-3254	C-27	4
MS35782-5	C-2	90
MS51412-25	C-2	23
MS51971-2	C-2	25
N1-1	C-2	4
P12934-010-01	C-27	17
P831520	C-2	47A
R61AWG18/19-9	BULK	13

Cross Reference Indexes

Part Number Index

Part Number	FIG.	Item	
S05300F	C-2	211	
	C-2	214	
	C-2	224	
	C-2	228	
	C-2	232	
	C-2	234	
	C-2	238	
	C-2	241	
	C-2	251	
	C-2	253	
	C-2	257	
	C-20	2	
	C-21	19	
	C-22	10	
	C-23	8	
	C-27	48	
	C-27	51	
	C-27	55	
	C-27	59	
	C-27	62	
	C-28	9	
	S05300F	C-17	9
	SYSTEM-1	C-8	4
SYSTEM-2	C-8	2	
SYSTEM-3	C-8	3	
SYSTEM-4	C-8	1	
UM4073	C-2	69	
VF4-15H11-S05	C-2	153	
W212NAA0060NN041NNCG1	C-2	60	
	C-7	3	
X-1054	BULK	6	

APPENDIX D

COMPONENTS OF END ITEM AND BASIC ISSUES ITEMS LIST
Section I. INTRODUCTION

D-1. SCOPE.

This appendix lists components of the end item and basic issue items for the Auxiliary Power Unit 10 kW, 120/240 VAC, 60 Hz (APU) to help you inventory the items for safe and efficient operation of the equipment.

D-2. GENERAL.

The Components of End Item (COEI) and Basic Issue Items (BII) lists are divided into the following sections:

D-2.1. Components of End Item. This listing is for information purposes only, and is not authority to requisition replacements. These items are part of the APU. As part of the end item, these items must be with the end item whenever it is issued or transferred between property accounts. Items of the COEI are removed and separately packaged for transportation or shipment only when necessary. Illustrations are furnished to help you find and identify the items.

D-2.2. Basic Issue Items. These essential items are required to place the APU in operation, operate it, and to do emergency repairs. Although shipped separately packaged, BII must be with the APU during operation and when it is transferred between property accounts. The list is your authority to request/requisition them for replacement based on authorization of the end item by the TOE/MTOE. Illustrations are furnished to help you find and identify the items.

D-3. EXPLANATION OF COLUMNS.

The following provides an explanation of columns found in the tabular listings.

- a. Column (1), Illustration Number. Gives you the number of the item illustrated.
- b. Column (2), National Stock Number. Identifies the stock number of the item for requisitioning purposes.
- c. Column (3), Description and Usable On Code. Identifies the Federal item name (in all capital letters) followed by a minimum description when needed. The last line below the description is the Commercial and Government Entity Code (CAGEC) (in parenthesis) and the part number. If the item you need is not the same for different models of the equipment, a Usable On Code will appear on the right side of the description column on the same line as the part number. These codes are identified at the top of the next page:

CODE

FPA
 FPB
 LTG

USED ON

Model MEP-903B
 Model MEP-903A
 Model MEP-903C

ARMY TM 9-6115-670-14&P

- d. Column (4), U/I (Unit of Issue). Indicates how the item is issued for the National Stock Number shown in column two.
- e. Column (5), Qty Rqd (Quantity Required). Indicates the quantity required.

Section II. COMPONENTS OF END ITEM

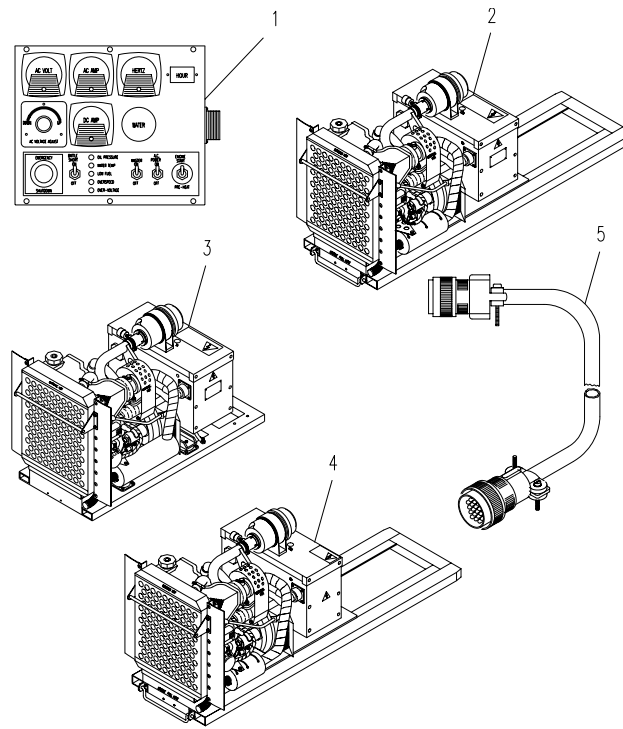

Figure D-1. Auxiliary Power Unit, 10 kW, 120/240 VAC, 60 Hz

(1) Illus No	(2) National Stock Number	(3) Description CAGEC and Part Number	Usable On Code	(4) U/I	(5) Qty Rqr
		AUXILIARY POWER UNIT, 10 KW, 120/240 VAC, 60 HZ		EA	1
	6115-01-431-3062	(97403) 13230E6218 (SICPS)	FPB		
	6115-01-458-5329	(97403) 13230E6815 (WIN-T)	LTG		
	6115-01-431-3063	(29381) 7032915-501(JTACS)	FPA		
		Consisting of:			
1	6110-01-478-7200	CONTROL BOX (97403) 13230E6220		EA	1
		G16126 (MEP903B) (JTACS and WIN-T)	FPA		
		G96AGW (S-832/G)	LTG		
	6110-01-494-3003	G71312MCN CONTROL BOX			
		29381 4831002C	FPA		
2	6115-01-458-5329	GENERATOR, 10 KW APU (WIN-T) (30554) MEP-903C	LTG	EA	1
3	6115-01-431-3062	GENERATOR 10 KW, APU (SICPS) (30554) MEP-903A		EA	1
			FPB		
4	6115-01-431-3063	GENERATOR, 10 KW APU (JTACS) (30554) MEP-903B		EA	1
			FPA		
5	6150-01-482-4325	WIRING HARNESS, CONTROL CABLE		EA	1
		(97403) 13230E6308 (SICPS) or	FPB		
		(97403) 13230E6847 (WIN-T)	LTG		
		(97403) 13230E6300 (JTACS)	FPA		

Section III. BASIC ISSUE ITEMS

ARMY TM 9-6115-670-14&P

**OPERATOR'S, UNIT, DIRECT SUPPORT AND
GENERAL SUPPORT MAINTENANCE
MANUAL (INCLUDING REPAIR PARTS AND
SPECIAL TOOLS LIST) FOR**

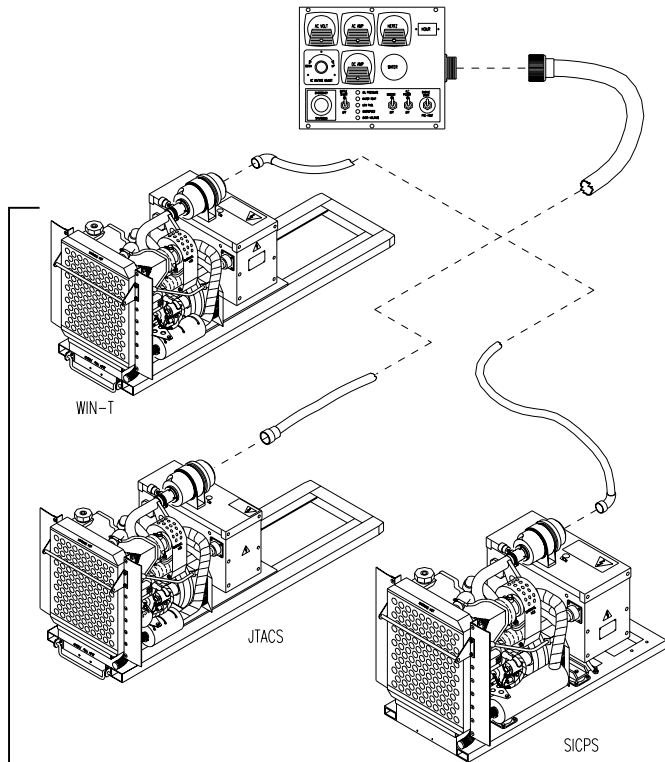

**AUXILIARY POWER UNIT
10 KW, 120/240 VAC, 60 HZ
MODEL NO. MEP-903A (SICPS)
NSN 6115-01-431-3062,
MODEL NO. MEP-903B (JTACS)
NSN 6115-01-431-3063,
MODEL NO. MEP-903C (WIN-T)
NSN 6115-01-458-5329
(EIC: N/A)**

DISTRIBUTION STATEMENT A: Approved for public release; distribution is unlimited.

OPERATING INSTRUCTIONS	PAGE 2-1
OPERATOR MAINTENANCE	PAGE 3-1
OPERATOR TROUBLE-SHOOTING	PAGE 3-1
UNIT MAINTENANCE	PAGE 4-1
UNIT TROUBLESHOOTING	PAGE 4-10
DIRECT SUPPORT MAINTENANCE	PAGE 5-1
DIRECT SUPPORT TROUBLE SHOOTING	PAGE 5-2
GENERAL SUPPORT MAINTENANCE	PAGE 6-1

HEADQUARTERS, DEPARTMENT OF THE ARMY

1 August 2002

(1) Illus No	(2) National Stock Number	(3) Description CAGEC and Part Number	Usable On Code	(4) U/I	(5) Qty Rqr
		TECHNICAL MANUAL TM 9-6115-670-14&P		EA	1

Figure D-2. Operator's, Unit, Direct Support, and General Support Maintenance Manual

APPENDIX E

ADDITIONAL AUTHORIZATION LIST

Section I. INTRODUCTION

E-1. SCOPE.

This appendix lists additional items you are authorized for the support of the Auxiliary Power Unit (APU).

E-2. GENERAL.

This list identifies items that do not have to accompany APU and that do not have to be turned in with it. These items are all authorized to you by CTA, MTOE, TDA, or JTA.

E-3. EXPLANATION OF LISTING.

The following provides an explanation of columns found in the tabular listings.

- a. Column (1), National Stock Number. Indicates the national stock number assigned to the item and will be used for requisitioning purposes.
- b. Column (2), Description CAGEC and Part Number. Indicates the national item name and, if required, a minimum description to identify and locate the item. The last line for each item indicates the Commercial and Government Entity (CAGE) Code (in parenthesis) followed by the part number. If items needed differ for different models of this equipment, the model is shown under the Usable On heading in this column.

<u>CODE</u>	<u>USABLE ON</u>
FPA	Model MEP-903B
FPB	Model MEP-903A
LTG	Model MEP-903C

- c. Column (3), Unit of Measure. Indicates the unit of measure (U/M) used in performing the actual operational/maintenance function. This measure is expressed by a two-character alphabetical abbreviation (e.g., EA, IN, PR).
- d. Column (4), Quantity Authorized. Indicates the quantity authorized (Qty. Auth.) of the item authorized to be used with/on the equipment.

Section II. ADDITIONAL AUTHORIZATION LIST

Table E-1. Additional Authorization List

(1) National Stock Number	(2) Description CAGEC and Part Number	Usable On Code	(3) U/M	(4) Qty. Auth.
	NOT APPLICABLE			

APPENDIX F**EXPENDABLE AND DURABLE PARTS ITEMS LIST****Section I. INTRODUCTION****F-1. SCOPE.**

This appendix lists the expendable and durable items that you will need to operate and maintain the Auxiliary Power Unit. This listing is for information only and is not authorization to requisition the listed items. These items are authorized to you by CTA 50-790, Expendable/Durable Items (Except Medical, Class V, Repair Parts and Heraldic Items), or CTA 8-100, Army Medical Department Expendable/Durable Items.

F-2. EXPLANATION OF COLUMNS.

- a. Column (1), Item Number. This number is assigned to the entry in the listing and is referenced in the set-up instructions to identify the item (e.g., "Sealing Compound, Item 17, Appendix F").
- b. Column (2), Level. This column identifies the lowest level of maintenance that requires the item.
- c. Column (3), National Stock Number. This is the national stock number assigned to the item which you can use to requisition it.
- d. Column (4), Item Name, Description, Commercial and Government Entity Code (CAGEC) and Part Number. This provides the other information you need to identify the item.
- e. Column (5), Unit of Measure (U/M). This code shows the physical measurement or count of an item, such as gallon, dozen, gross, etc.

Section II. EXPENDABLE/DURABLE SUPPLIES AND MATERIALS LIST

(1) Item Number	(2) Level	(3) National Stock Number	(4) Item Name, Description, CAGEC, Part Number	(5) U/M
1	O	8040-00-221-3811	ADHESIVE, RUBBER BASED, GENERAL PURPOSE, (97403) 13230E6684; (0HZU1) MA-212	GL
2	C	6850-00-181-7929	ANTIFREEZE (81349) MIL-A-46153	GL
3	H	5350-01-028-5203	COMPOUND, LAPPING (91104) YELLOW LABEL-80	LB
4	O	9140-00-286-5288	DIESEL FUEL (81348) VVF800GRADED1WI	GL
5	O	9140-00-221-2233	DIESEL FUEL (81348) VVF800	GL
6	O	9140-00-286-5282	DIESEL FUEL (81348) VVF800GRADEFAAR	GL
7			EPOXY INK, (30554) 71-4445	OZ
8	H	5210-00-640-6176	GAGE, BEARING CLEARANCE (77220) PLASTIGAGEPB1	EA
9	H	5210-00-640-6177	GAGE, BEARING CLEARANCE (77220) PLASTIGAGEPG1	EA
10	H	5210-00-640-6178	GAGE, BEARING CLEARANCE (77220) PLASTIGAGEPR1	EA
11	H	9150-00-076-1575	GREASE, BEARING (70201) 62	LB
12	H	6850-00-145-0255	INSPECTION PENETRANT KIT (81349) MIL-I-25135	EA
13	F		INSULATION SLEEVING, ELECTRICAL (30554) 88-20541-3; (28105) ST-301-1/16 BLACK; (1JX75) B2 1/16 BLACK	FT
14	F		INSULATION TAPE, THERMAL (97403) 13230E6325; (03HP3) 11002	FT
15	O	9140-00-242-4750	KEROSENE (81348) VV-K-211	GL
16	F		LOOM, CONVOLUTED, PLASTIC (97403) 13230E6820-3; (51705) 13159	IN
17	F		LOOM, CONVOLUTED, PLASTIC (97403) 13230E6820-4; (51705) 13160	IN
18	C	9150-00-247-0481	LUBRICATING OIL (81349) MIL-L-2104B	GL
19	C	9150-01-395-8983	LUBRICATING OIL (81349) MIL-L-2104F	GL
20	C	9510-00-111-3199	LUBRICATING OIL (81349) MIL-L-21260	GL
21	H	8010-00-239-5724	RED LEAD (81348) TTR191TYPE1GRADE97	LB
22	H	5320-00-754-0992	RIVET, SOLID (96906) MS-20470AD6-7	LB

Section II. EXPENDABLE/DURABLE SUPPLIES AND MATERIALS LIST

(1) Item Number	(2) Level	(3) National Stock Number	(4) Item Name, Description, CAGEC, Part Number	(5) U/M
23	F	9505-00-931-7272	SAFETY WIRE (81343) AMS5685	IN
24	F	8030-00-849-0071	SEALING COMPOUND (81349) MIL-S-45180	CC
25	O	8030-00-728-9665	SEALING COMPOUND (62377) 80017	CC
26	F	8030-01-270-3627	SEALING COMPOUND (70842) 765-1533	OZ
27	F	8030-00-118-0012	SEALING COMPOUND (30554) 88-20593; LM012 (61078)	CC
28	F	8030-00-252-3391	SEALING COMPOUND, FORM-A-GASKET, #2 SEALANT (62377) 80011; (30554) 88-20595-2	OZ
29	H	3439-00-912-8698	SOLDER, LEAD ALLOY (09823) 251-514	LB
30	F	9330-01-466-2457	SPIRAL WRAP TUBE (92194) SW-41; (97403) 13226E0099-2	IN
31	F	5975-00-111-3208	STRAP, TIEDOWN, ELECT (82152) APS20-119	LB
32	F	5975-01-206-2558	STRAP, TIEDOWN (30554) 88-20018-1; (06383) PLT 2S	LB
33	F	5975-01-034-1623	STRAP, TIEDOWN (30554) 88-20018-3; (06383) PLT 1.5I	LB
34	F	9330-01-207-8185	TUBING, PLASTIC, SPIRAL WRAP (97403) 13230E6313-1; (92194) SW-21	IN
35	F	9330-01-252-9648	TUBING, PLASTIC, SPIRAL WRAP (97403) 13230E6313-2; (92194) SW-22	IN

THIS PAGE INTENTIONALLY LEFT BLANK

APPENDIX G

OPERATOR'S LUBRICATION INSTRUCTIONS

G-1. SCOPE.

This appendix provides lubrication instructions for the Auxiliary Power Unit 10 kW, 120/240 VAC, 60 Hz (APU).

G-2. OPERATOR'S LUBRICATION INSTRUCTIONS.

The APU's engine oil level shall be checked on a daily basis (para 3.1.). Engine oil shall be replenished as needed. Engine oil shall be changed every 100 hours of operation (para 4.14.).

G-2.1. Oil Filter Replacement. The oil filter shall be replaced at the following intervals:

- a. With every oil change (each 100 hours of operation) (para 4.15.).
- b. When it is known to be contaminated or clogged.

G-2.2. Army Oil Analysis Program. The APU is not enrolled in the Army Oil Analysis Program. HARDTIME INTERVALS APPLY.

G-2.3. Warranty Hardtime Statement. For equipment under manufacturer's warranty, hardtime oil service intervals shall be followed. Intervals shall be shortened if lubricants are known to be contaminated or if operation is under adverse conditions (such as longer than usual operating hours, extended idling periods, and extreme dust).

G-2.4. Corrosion Prevention Control (CPC). Refer to Chapter 1 of this technical manual (TM) for CPC instructions.

G-3. LUBRICANT TABLE.

Table G-1 identifies lubricants and the ambient temperatures they should be used in.

G-4. EXPLANATION OF COLUMNS.

The following provides an explanation of columns found in the tabular listings:

- a. Column 1, Temperature Range. Identifies temperature range that lubricant should be used in.
- b. Column 2, Lubricant Mil Symbol Specification. Identifies the military specification for each lubricant.
- c. Column 3, Capacity. Specifies the amount of lubricant in quarts (qt.) and liters (l) to be used with each oil change.

ARMY TM 9-6115-670-14&P

- d. Column 4, Interval (H). Specifies in hours of operation (H) how often the lubricant should be changed.
- e. Column 5, Man-Hour. Specifies the number of man-hours needed to change the lubricant.

Table G-1. Lubricant Table for the APU

(1) Temperature Range	(2) Lubricant Mil Symbol Specification	(3) Capacity	(4) Interval (H)	(5) Man-Hour
Above 77°F (25°C)	MIL-L-21260D (SAE 30W OR 10W-30)	4 qt. (3.8 l)	100	0.5
32°F to 77°F (0°C to 25°C)	MIL-L-2104F (SAE 20W OR 10W-30)	4 qt. (3.8 l)	100	0.5
Below 32°F (0°C)	MIL-L-21260 (SAE 10W OR 10W-30)	4 qt. (3.8 l)	100	0.5
Below 32°F (0°C) to above 77°F (25°C)	MIL-L-2104B	4 qt. (3.8 l)	100	0.5

APPENDIX H

ILLUSTRATED LIST OF MANUFACTURED ITEMS

Section I. INTRODUCTION

H-1. INTRODUCTION.

This appendix includes complete instructions for making items authorized to be manufactured or fabricated.

A part number index in alphanumeric order is provided for cross-referencing the part number of the item to be manufactured to the figure which covers fabrication criteria.

All bulk materials needed for manufacture of an item are listed by part number or specification number in a tabular list on the illustration.

H-2. MANUFACTURED ITEMS PART NUMBER INDEX.

Part Number	Figure Number
APUMT1	Figure H-1. Valve Guide Replacing Tool
APUMT2	Figure H-2. Crankshaft Bearing 1 Replacing Tool
APUMT3	Figure H-3. Connecting Rod Small End Bushing Replacing Tool
APUMT4	Figure H-4. Idle Gear Bushing Replacing Tool
APUMT5	Figure H-5. Injection Pump Pressure Tester

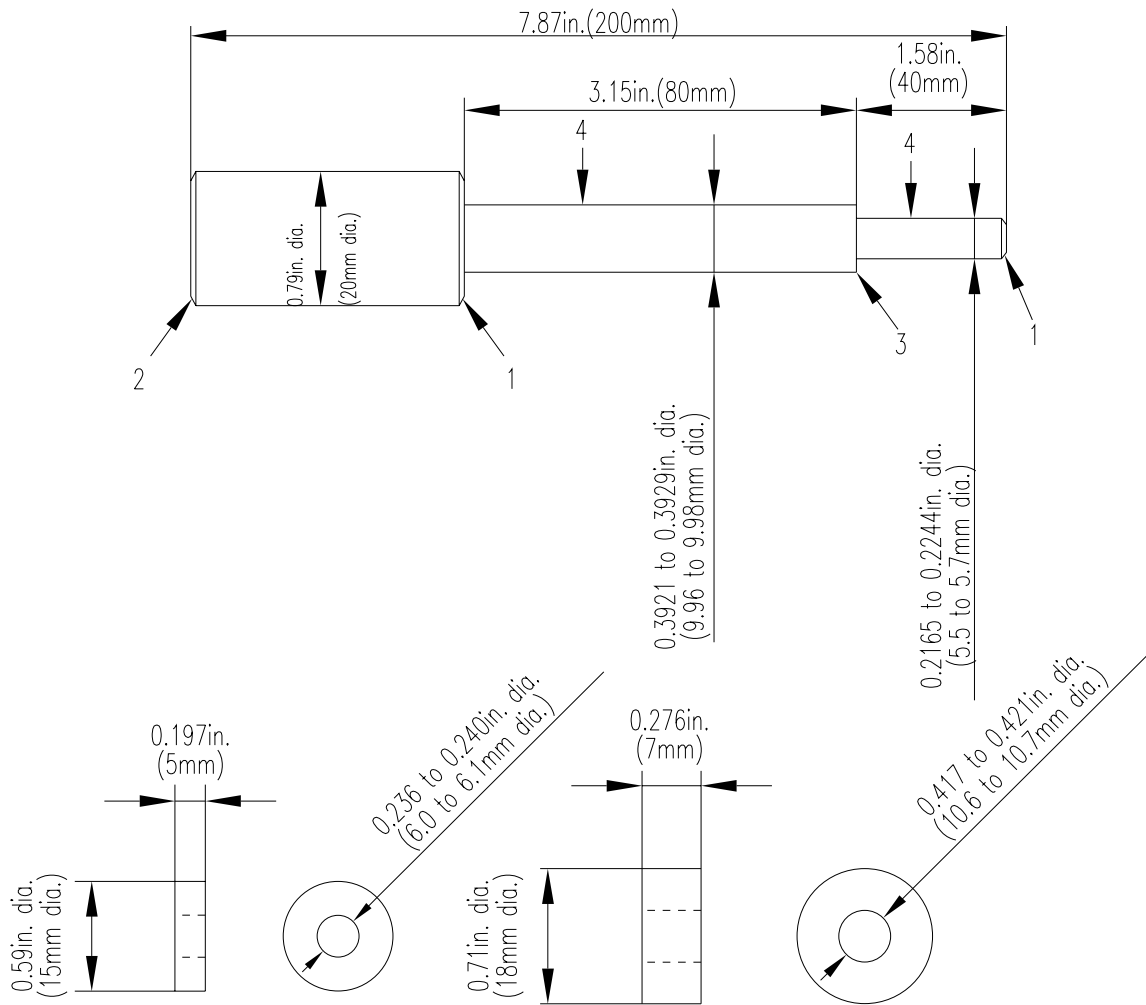

NOTES

- Dimensions are shown in inches (in.) and millimeters (mm) (in parenthesis).
- Materials and treatment are indicated in Table H-1.
- Tolerances are indicated in Figure H-1.
- Chamfer and fine finish are indicated in Table H-2.

Figure H-1. Valve Guide Replacing Tool

Table H-1. Materials and Specifications

Description	Specifications		Hardness	Hardness Penetration	Frequency of Use
	ISO	AISI SAE			
Chromium Molybdenm Steel	34CrMo4, 34CrMoS4	4137,	Induction Hardening HRC 52 to 59	0.039 to 0.079 in. (1 to 2 mm)	Frequent use
Carbon Steel for Machine Structural Use	—	1042, 1043	Induction Hardening HRC 48 TO 56	0.039 to 0.079 in. (1 to 2 mm)	Rare use
	C45, C45E4 C45M2	1045, 1046			

Table H-2. Chamfer and Fine Finish Requirements

No	Chamfer	Fine Finish
1	0.039 in. (1.0 mm)	—
2	0.079 in. (2.0 mm)	—
3	0.0102 in. (0.3 mm)	—
4	—	500 μin. (12.5 μmm)

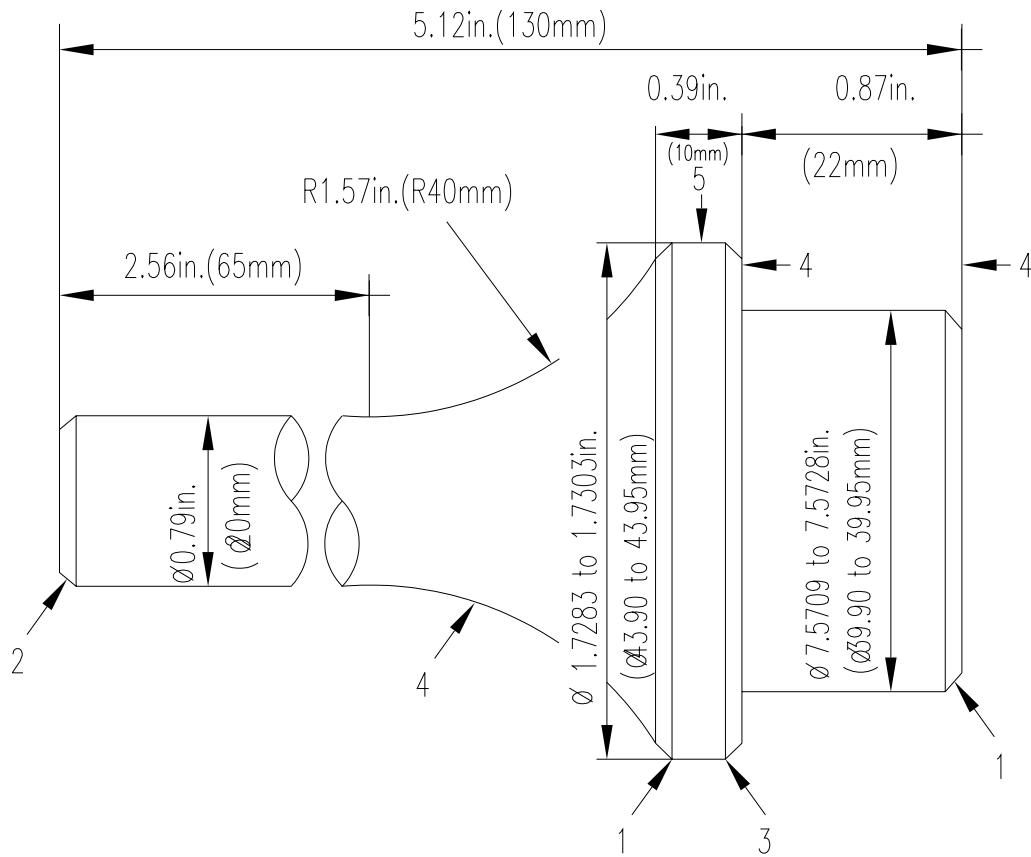

NOTES

- Dimensions are shown in inches (in.) and millimeters (mm) (in parenthesis).
- Tolerances are indicated in Figure H-2.
- Materials and treatment are indicated in Table H-3.
- Chamfer and fine finish are indicated in Table H-4.

Figure H-2. Crankshaft Bearing 1 Replacing Tool

Table H-3. Materials and Specifications

Description	Specifications		Hardness	Hardness Penetration	Frequency of Use
	ISO	AISI SAE			
Chromium Molybdenm Steel	34CrMo4, 34CrMoS4	4137	Induction Hardening HRC 52 to 59	0.039 to 0.079 in. (1 to 2 mm)	Frequent use
Carbon Steel for Machine Structural Use	—	1042, 1043	Induction Hardening HRC 48 TO 56	0.039 to 0.079 in. (1 to 2 mm)	Rare use
	C45, C45E4, C45M2	1045, 1046			

Table H-4. Chamfer and Fine Finish Requirements

No	Chamfer	Fine Finish
1	0.039 in. (1.0 mm)	—
2	0.079 in. (2.0 mm)	—
3	0.0102 in. (0.3 mm)	—
4	—	500 μ in. (12.5 μ mm)
5	—	250 μ in. (6.3 μ mm)

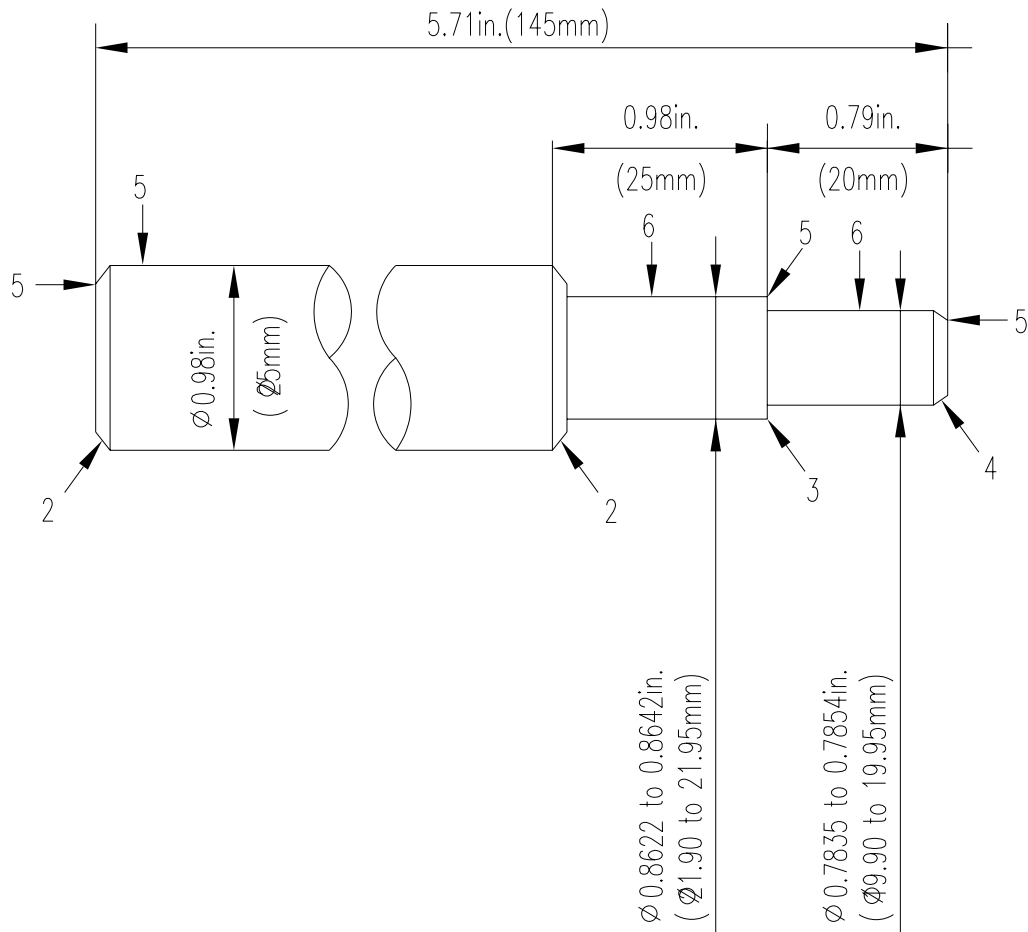

NOTES

- Dimensions are shown in inches (in.) and millimeters (mm) (in parenthesis).
- Tolerances are indicated in Figure H-3.
- Materials and treatment are indicated in Table H-5.
- Chamfer and fine finish are indicated in Table H-6.

Figure H-3. Connecting Rod Small End Bushing Replacing Tool

Table H-5. Materials and Specifications

Description	Specifications		Hardness	Hardness Penetration	Frequency of Use
	ISO	AISI SAE			
Chromium Molybdenum Steel	34CrMo4, 34CrMoS4	4137	Induction Hardening HRC 52 to 59	0.039 to 0.079 in. (1 to 2 mm)	Frequent use
Carbon Steel for Machine Structural Use	—	1042/1043	Induction Hardening HRC 48 TO 56	0.039 to 0.079 in. (1 to 2 mm)	Rare use
	C45, C45E4, C45M2	1045, 1046			

Table H-6. Chamfer and Fine Finish Requirements

No	Chamfer	Fine Finish
1	0.039 in. (1.0 mm)	—
2	0.079 in. (2.0 mm)	—
3	0.0102 in. (0.3 mm)	—
4	0.157 in. (4.0 mm)	—
5	—	500 μin. (12.5 μmm)
6	—	250 μin. (6.3 μmm)

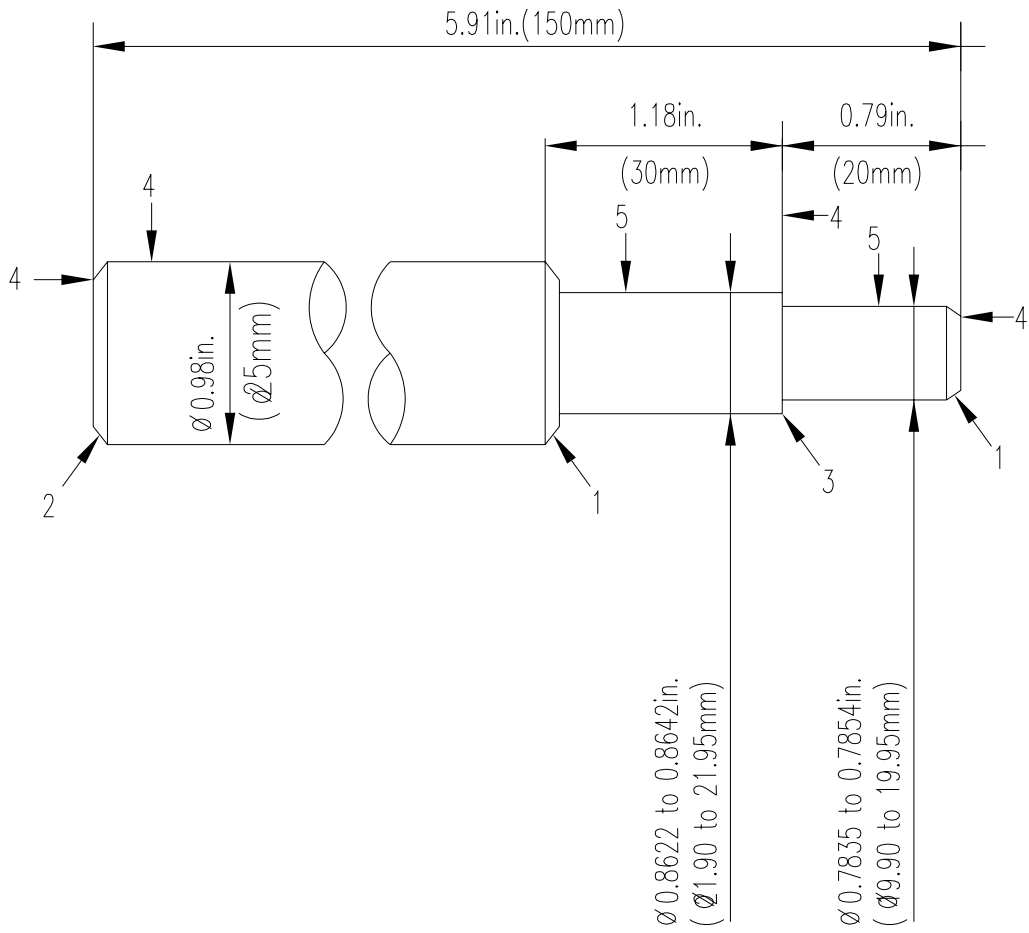

NOTES

- Dimensions are shown in inches (in.) and millimeters (mm) (in parenthesis).
- Tolerances are indicated in Figure H-3.
- Materials and treatment are indicated in Table H-7.
- Chamfer and fine finish are indicated in Table H-8.

Figure H-4. Idle Gear Bushing Replacing Tool

Table H-7. Materials and Specifications

Description	Specifications		Hardness	Hardness Penetration	Frequency of Use
	ISO	AISI SAE			
Chromium Molybdenum Steel	34CrMo4, 34CrMoS4	4137	Induction Hardening HRC 52 to 59	0.039 to 0.079 in. (1 to 2 mm)	Frequent use
Carbon Steel for Machine Structural Use	—	1042/ 1043	Induction Hardening HRC 48 TO 56	0.039 to 0.079 in. (1 to 2 mm)	Rare use
	C45, C45E4, C45M2	1045 1046			

Table H-8. Chamfer and Fine Finish Requirements

No	Chamfer	Fine Finish
1	0.039 in. (1.0 mm)	—
2	0.079 in. (2.0 mm)	—
3	0.0102 in. (0.3 mm)	—
4	—	500 μ in. (12.5 μ mm)
5	—	250 μ in. (6.3 μ mm)

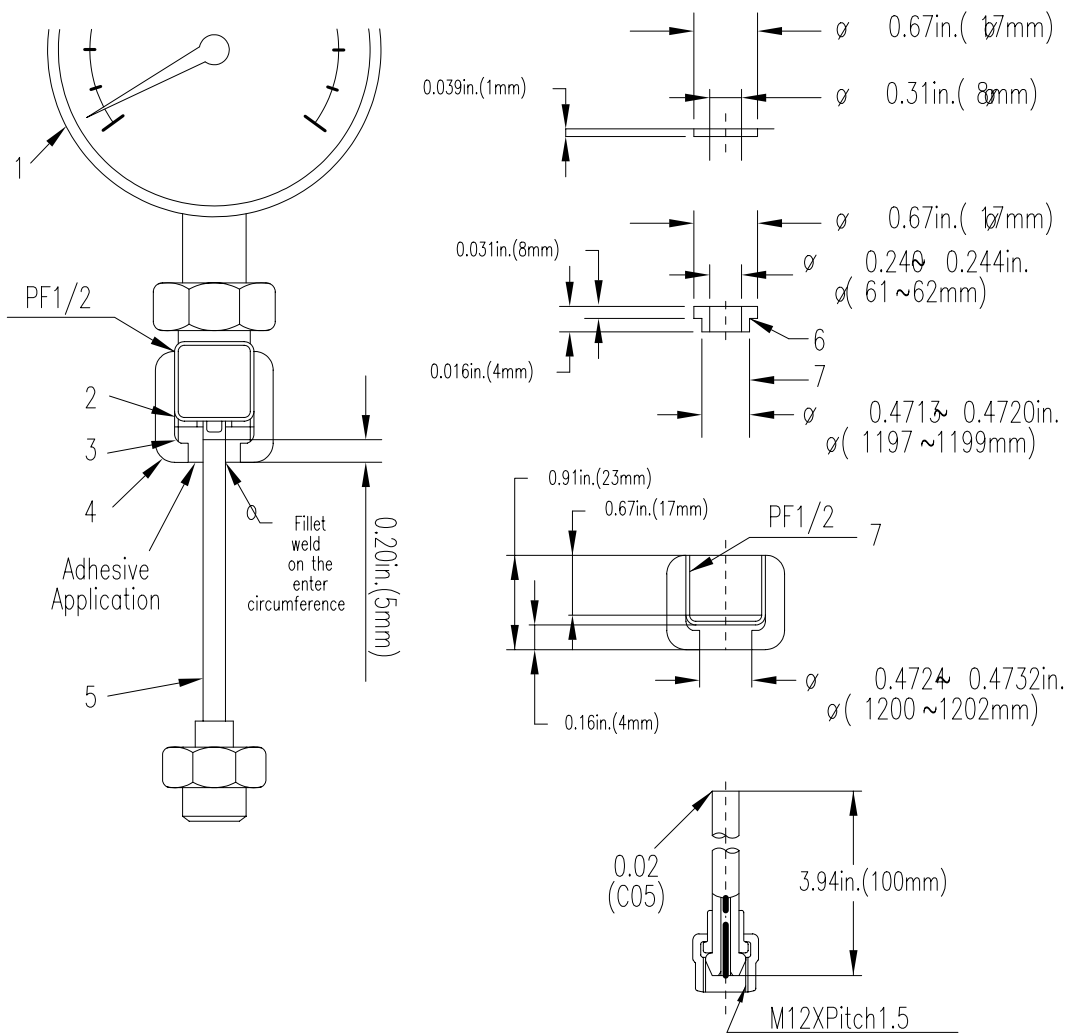

NOTES

- Dimensions are shown in in. and mm (in parenthesis).
- Tolerances are indicated in illustration.
- Weld all joints shown. All welding shall be in accordance with MIL-W-45205, Class B.
- Refer to Table H-9 for parts, materials, and specifications.
- Refer to Table H-10 for chamfer and fine finish requirements.

Figure H-5. Injection Pump Pressure Tester

Table H-9. Parts, Materials, and Specifications

No	Part	Material	Specifications	NSN
1	Pressure Gauge, Full Scale	—	Full scale More than 4267 psi (26.9 MPa)	
2	Gasket	Copper		
3	Flange	Carbon Steel for Machine Use	ISO	
			C45, C45EF4, or, C45M2	
4	Hex Nut	Carbon Steel for Machine Use	ISO	
			C45, C45EF4, or C45M2	
5	Injection Pipe	Chromium Steel Pipe for High Pressure Service	ISO	
			2604 (C)-75, 9329(1)-89	

Table H-10. Chamfer and Fine Finish Requirements

No	Chamfer	Fine Finish
6	0.02 in. (0.05 mm)	—
7	—	250 μ in. (6.3 μ mm)

THIS PAGE INTENTIONALLY LEFT BLANK

APPENDIX I
TORQUE LIMITS

I-1. SCOPE.

This appendix describes how to determine the torque limits for screws, bolts, and nuts used on the Auxiliary Power Unit (APU) to help you properly tighten fastener hardware for safe and efficient operation of the equipment.

I-2. TORQUE VALUES.

Screws, bolts and nuts must be tightened to the specified torque value using a torque wrench. Several fasteners, such as the screws, bolts, and nuts used on the APU engine cylinder head, must also be tightened in a set proper sequence. Tables I-1 and I-2 provide torque values for various kinds of general and special use hardware.

I-2.1. Torque Values for Special Use Screws, Nuts, and Bolts. Table I-1 provides torque values for special use screws, nuts, and bolts. Identify the special use fastener under ITEM and read the torque from the columns to the right.

Table I-1. Torque Values for Special Use Screws, Bolts and Nuts

Item	Size x Pitch	Nm	Ft-Lbs
* Head cover cap nuts	M6 x 1.0	3.9 to 5.9	2.9 to 4.3
* Head bolts	M8 x 1.25	39.2 to 44.1	28.9 to 32.5
* Bearing case bolts 1	M6 x 1.0	12.7 to 15.7	9.4 to 11.6
* Bearing case bolts 2	M7 x 1.0	26.5 to 30.4	19.5 to 22.4
* Flywheel bolts	M10 x 1.25	53.9 to 58.8	39.8 to 43.4
* Connecting rod bolts	M7 x 0.75	26.5 to 30.4	19.5 to 22.4
* Rocker arm bracket nuts	M6 x 1.0	9.81 to 11.28	7.23 to 8.32
* Idle gear shaft bolts	M6 x 1.0	9.81 to 11.28	7.23 to 8.32
Glow plugs	M8 x 1.0	7.8 to 14.7	5.8 to 10.8
Nozzle holder assembly	M20 x 1.5	49.0 to 68.6	36.2 to 50.6
Oil switch taper screw	PT 1/8	14.7 to 19.6	10.8 to 14.5
Injection pipe retaining nuts	M12 x 1.5	24.5 to 34.3	18.1 to 25.3

For "*" marked screws, bolts, and nuts, apply engine oil to threads and seats before tightening.

I-2.2. Torque Values for General Use Screws, Bolts, and Nuts. When torque values are not provided for a specific fastener or application, tighten the screw, bolt, or nut according to the values in Table I-2. General and special use material grades are shown by numbers punched on screw and bolt heads. Prior to tightening, verify the fastener material using the numbers shown in Table I-2.

Table I-2. Torque Values for General Use Screws, Bolts, and Nuts

Nominal Diameter	Grade	Standard Screw and Bolt (Identify by plain head or punched number 4 on head. Material grade SS41 or S20C.)		Special Screw and Bolt (Identify by punched number 7 on head. Material grade S43C or S48C (Refined).)	
		Nm	Ft-Lbs	Nm	Ft-lbs
M6		7.9 to 9.3	5.8 to 6.9	9.8 to 11.3	7.23 to 8.32
M8		17.7 to 20.6	13.0 to 15.2	23.5 to 27.5	17.4 to 20.3
M10		39.2 to 45.1	28.9 to 33.3	48.1 to 55.9	35.4 to 41.2
M12		62.8 to 72.6	46.3 to 53.5	77.5 to 90.2	57.1 to 66.5

I-3. TIGHTENING METAL FASTENERS.

When torquing a fastener, select a wrench with a range which fits the required torque value. A torque wrench is most accurate from 25 percent to 75 percent of its stated range. A wrench with a stated range of 0 to 100 ft-lbs will be most accurate from 25 to 75 ft-lbs. The accuracy of readings will decrease as you approach 0 ft-lbs or 100 ft-lbs. The ranges in Table I-3 are based on this principle.

Table I-3. Torque Ranges - Typical

Stated Range	Most Effective Range
0 - 200 in.-lbs 0 - 225.8 Nm	50 - 150 in.-lbs 56.4 - 169.3
0 - 600 ft-lbs 0 - 813.6 Nm	150 - 450 ft-lbs 203.4 - 610.2 Nm
0 - 170 ft-lbs 0 - 230.5 Nm	43 - 127 ft-lbs 58.3 - 172.2 Nm

APPENDIX J

MANDATORY REPLACEMENT PARTS

Section I. INTRODUCTION

J-1. SCOPE.

This Appendix lists items that are required to be replaced every time an old item is removed.

J-2. EXPLANATION OF COLUMNS.

The following provides an explanation of columns found in the tabular listings.

- a. Column (1), Item Number. This number is assigned to each entry in the listing.
- b. Column (2), Description and Part Number. Indicates the national item name followed by the part number.
- c. Column (3), National Stock Number. Indicates the national stock number assigned to the item and will be used for requisitioning purposes.
- d. Column (4), Quantity Required. Indicates the quantity required (Qty Reqd) of the item to be replaced.

Section II. MANDATORY REPLACEMENT PARTS LIST

(1) Item No.	(2) Description/Part No.	(3) National Stock Number	(4) Qty Reqd
1	GASKET, BEARING CASE COVER (OXWR1) 15841-0482-2	5330-01-478-5159	1
2	GASKET, CYLINDER HEAD (OXWR1) 16881-0331-0 (WIN-T) (OXWR1) 16871-0331-0 (JTACS)	5330-01-478-4843	1
3	GASKET, EXHAUST MANIFOLD (OXWR1) 15862-1235-0	5330-01-478-5169	1
4	GASKET, FEEDER FUEL PUMP (OXWR1) 16264-5214-0	5330-01-478-6366	1
5	GASKET, GEAR CASE (OXWR1) 15862-0413-2	5330-01-478-5153	1
6	GASKET, INTAKE MANIFOLD (OXWR1) 15861-1182-0	5330-01-478-5164	1
7	GASKET, MUFFLER (OXWR1) 15263-1237-0	5330-01-446-2136	1
8	GASKET, OIL COOLER (OXWR1) 16299-3367-0	5330-01-478-5144	1
9	GASKET, OIL PUMP (OXWR1) 16851-3515-2	5330-01-478-6354	1
10	GASKET, THERMOSTAT HOUSING (OXWR1) 16851-7327-0	5330-01-437-1059	1
11	GASKET, WATER FLANGE (OXWR1) 15841-7292-2	5330-01-478-5146	1
12	GASKET, WATER PUMP (OXWR1) 15881-7343-2		1
13	O-RING, GEAR CASE (OXWR1) 04811-06130	5331-01-478-4867	3
14	O-RING, OIL COOLER (OXWR1) 04814-50600	5331-01-478-4871	1
15	SEAL, OIL (OXWR1) 15877-0414-0	5330-01-478-4887	1
16	OIL GASKET, TURBO CHARGER (OXWR1) 16299-1711-0		1
17	GASKET, TURBOCHARGER (OXWR1) 16299-1710-0		1

Section II. MANDATORY REPLACEMENT PARTS LIST

(1) Item No.	(2) Description/Part No.	(3) National Stock Number	(4) Qty Reqd
18	GASKET, FLANGE (OXWR1) 19483-3312-0 (WIN-T) (OXWR1) 19461-8813-2 (JTACS)		1
19	GASKET, BEARING CASE (OXWR1) 15852-0436-0	5330-01-478-5156	1
20	PACKING, PREFORMED, OIL PAN STRAINER (OXWR1) 04811-00160	2815-01-439-4961	1
21	GASKET, WASHER, INJECTION NOZZLE (OXWR1) 15841-5362-2		3
22	GASKET, OIL PAN (OXWR1) 15451-9667-0	2990-01-438-8808	1

ALPHABETICAL INDEX

Subject	Para	Fig.	Table	Subject	Para	Fig.	Table
A				Current Shunt	4.55.	F4-43	
Abbreviations, List of	1.9.			Cylinder	6.30.	F6-27	
AC Voltage Adjust Potentiometer	4.59.	F4-47		Cylinder Head	6.5.	F6-2	
Actuator Linkage	4.50.	F4-38		Cylinder Head Cover	4.64.	F4-52	
Actuator Solenoid	4.49.	F4-37		D			
Administrative Storage	1.3.			DC Box Subassembly	5.19.	F5-13	
Administrative Storage, Special Instructions for	4.13.			Decontamination Procedures, Nuclear, Biological, & Chemical	2.11.		
Air Filter, Engine	4.45.	F4-33		Desert Climate, Operation In	2.8.		
Air Intake Pipe	4.47.	F4-35		Destruction of Army Material to Prevent Enemy Use	1.4.		
Alternator, Battery Charging	4.36.	F4-24		Diesel Engine	5.33.	F5-25	
APU Control Unit (Controls and Indicators)	2.1.	F2-1	T2-1	Differences Between Models	1.12.		T1-1
APU Control Unit (Description)	1.13.7.			Direct Support Troubleshooting Procedures	5.5.		
APU Control Unit Start-Up Switch Positions			T2-3	E			
APU DC Box Wiring Harness J3	5.26.	F5-19.	T5-1	Electrical System (Operation)	1.16.6.	F1-8	
APU Painting	3.4.			Electrical Meters	4.57.	F4-45	
APU Wiring Diagram		FO-1		Electrical Output Terminal Board	4.51.	F4-39	
Arctic Climate, Operation In	2.7.			Emergency Shut-Down Switch	4.60.	F4-48	
Automatic Voltage Regulator	5.22.	F5-16		Engine Air Filter	4.45.	F4-33	
Auxiliary Power Unit (Data)	1.14.1.			Engine Coolant Drain Valve	4.21.	F4-8	
Auxiliary Power Unit (DS)	5.6.			Engine (Data)	1.14.2.		
AVR and Diesel Engine Interface	1.17.3.			Engine (Description)	1.13.1.		
B				Engine Electrical System (Data)	1.14.8.		
Battery Charging Alternator	4.36.	F4-24		Engine Generator Mule	5.33.		
Bearing Case Cover	6.25	F6-22		Engine Oil	3.6., 4.14.	F3-2, F4-1	
Bleeding Fuel System (Service)	4.29.	F4-16		Engine Operation	1.16.		
Breather	4.27.	F4-14		Combustion System	1.16.1.	F1-3	
C				Cooling System	1.16.3.	F1-5	
Camshaft	6.16.	F6-13		Electrical System	1.16.6.	F1-8	
Camshaft Gear	6.17.	F6-14		Fuel System	1.16.4	F1-6	
Combustion System	1.16.1.	F1-3		Intake/Exhaust System	1.16.5.	F1-7	
Common Tools and Equipment	4.2.			Lubrication System	1.16.2.	F1-4	
Common Tools and Equipment (Direct Support)	5.2.			Engine Speed Control System	1.18.1.	F1-10	
Common Tools and Equipment (GS)	6.2.			Engine Turbocharger	4.44.	F4-32	
Connecting Rod	6.23.	F6-20		Equipment Characteristics, Capabilities and Features	1.11.		
Connecting Rod Bearing	6.27.	F6-24		Characteristics (Equipment)	1.11.1.		
Contacting Mounting Plate	4.52.	F4-40		Capabilities (Equipment)	1.11.2.		
Contacting Plate	5.17.	F5-11		Features (Equipment)	1.11.3.		
Control Operation	1.18.			Equipment Data	1.14.		
Current Control	1.18.2	F1-11		Exciter Stator	6.34.	F6-31	
Engine Speed Control System	1.18.1	F1-10		Exhaust Pipe (JTACS & WIN-T)	4.42.	F4-30	
Controls and Indicators, Description And Use, APU Control Unit	2.1.			Exhaust Pipe (SICPS)	4.43.	F4-31	
Coolant Drain Valve, Engine	4.21.	F4-8		Exhaust Manifold	5.34.	F5-26	
Coolant Drain Valve, Radiator	4.20.	F4-7		F			
Cooling System	1.16.3., 4.6.2.	F1-5		Fan Belt (Unit Maintenance)	4.23.	F4-10	
Cooling System (Data)	1.14.7.			Fan Guard, Fan Shroud, and Shroud Housing	4.18.	F4-5	
Cooling System (Description)	1.13.6			Faring, Radiator Seal	6.32.	F6-29	
Corrosion Prevention and Control	1.8.			Flywheel	5.38.	F5-30	
Crankshaft	6.26.	F6-23		Frame Assembly (Models MEP- 903A, MEP-903B & MEP-903C) And Vibration Isolator Mount			
Crankshaft Bearing 1	6.28.	F6-25		Assembly (MEP-903B & MEP- 903A)	5.32.	F5-24	
Crankshaft Bearings 2 and 3	6.29.	F6-26					
Crankshaft Gear	6.20.	F6-17					
Current Control	1.18.2	F1-11					
Current Transformer	5.15.	F5-9					

ALPHABETICAL INDEX (Continued)

Subject	Para	Fig.	Table	Subject	Para	Fig.	Table
Freezing Points, Composition, And Specific Gravities of Military Antifreeze Materials			T4-1	Lines and Fittings, Fuel	4.35.	F4-22	
Fuel Camshaft	6.18.	F6-15		List of Abbreviations	1.9.	F4-23	
Fuel Feeder Pump	4.34.	F4-21		Location and Description Of Major Components	1.13.	F1-1	
Fuel Filter Assembly	4.30.	F4-17		Low Oil Pressure Switch	4.17.	F4-4	
Fuel Lines and Fittings (SICPS, JTACS, and WIN-T)	4.35.	F4-22, F4-23		Lubrication System	1.16.2.		
Fuel Pump Assembly	4.31.	F4-18		Lubrication System (Data)	1.14.5.		
Fuel System	1.16.4., 4.29.	F1-6, F4-16		Lubrication System (Description)	1.13.4.		
Fuel System (Data)	1.14.6.			Lubrication Instructions	3.1.	G-1	
Fuel System (Description)	1.13.5.				4.1.		
Fuel Day Tank Assembly (JTACS And WIN-T)	4.32.	F4-19			4.9.		
Fuel Day Tank Assembly (SICPS)	4.33.	F4-20					
	G			M			
Gear Case	6.12.	F6-9		Major Components, Location and Description of	1.13.	F1-1	
Generator, 10kW, 60 Hz	5.24.	F5-18		Main AC Contactor	4.53.	F4-41	
Generator Bearing	6.36.	F6-33		Main Rectifier Assembly	6.35.	F6-32	
Generator Circuit	1.17.1.			Maintenance Forms, Records And Reports	1.2		
Generator (Data)	1.14.3.			Main Stator and Automatic Voltage Regulator (AVR)			
Generator (Description)	1.13.2.			Interface	1.17.2.	F1-9	
Generator Operation	1.17.			Muffler (JTACS and WIN-T)	4.40.	F4-28	
AVR and Diesel Engine Interface	1.17.3	F1-9		Muffler (SICPS)	4.41.	F4-29	
Generator Circuit	1.17.1.			Muffler Wrap	4.39.	F4-27	
Main Stator and Automatic Voltage Regulator (AVR) Interface	1.17.2.	F1-9					
Glossary	1.10.			N			
Glow Plug (Unit Maintenance)	4.38.	F4-26		Nomenclature Cross-Reference List	1.5.		
Governor Control Assembly	4.48.	F4-36		Nuclear, Biological, and Chemical (NBC)			
Governing System (Data)	1.14.4.			Decontamination Procedure	2.11.		
Governing System (Description)	1.13.3.						
Ground Strap	4.54.	F4-42		O			
Guard, Fan	4.18.	F4-5		Oil Cooler	4.16.	F4-3	
	H			Oil Dipstick	3.5.	F3-1	
Hoses, Radiator	4.24.	F4-11		Oil Filter	4.15.	F4-2	
Hour Meter	4.58.	F4-46		Oil Pan	5.8.	F5-2	
	I			Oil Pan Cover	5.7.	F5-1	
Idle Gear	6.13.	F6-10		Oil Pan Strainer	5.9.	F5-3	
Idle Gear Bushing	6.14.	F6-11		Oil Pump Assembly	6.31.	F6-28	
Idle Gear Shaft	6.15.	F6-12		Oil Pump Gear	6.21.	F6-18	
Indicator Lamps	4.63.	F4-51		Operation Under Usual Conditions			
Injection Pump	5.14.	F5-8		Assembly & Preparation for Use	2.3.		
Injection Pump Gear	6.19.	F6-16		Operating Procedures	2.5.		
Injection Nozzle Assembly	5.13.	F5-7		Preoperational Checks	2.4.		
Inspection (Service Upon Receipt)	4.5.			Shut-Down	2.6.		
Instructions and Warning Plates	1.15.	F1-2		Operation Under Unusual Conditions			
Intake/Exhaust System	1.16.5	F1-7		Nuclear, Biological, and Chemical (NBC) Decontamination			
Intake Manifold	5.35.	F5-27		Procedures	2.11.		
	L			Operation in Artic Climate	2.7.		
Leakage Definitions	2.2.5.			Operation in Desert Climate	2.8.		
	4.7.4.			Operation In Salt Air or Sea Spray	2.10.		
Leaks, Minor, Operation of Generator Set With	2.2.6.			Operation in Tropical Climate	2.9.		
	4.7.5.			Operator Troubleshooting Procedures	3.3		
				Operator PMCS Routing Diagram		F2-2	
				Operator PMCS Table, Introduction To Operator PMCS	2.2.		
				Overflow Tank, Radiator	4.28.	F4-15	
				Overload Relay	5.16.	F5-10	
							T2-2

ALPHABETICAL INDEX (Continued)

Subject	Para	Fig.	Table	Subject	Para	Fig.	Table
	P			Toggle Switches	4.61.	F4-49	
Painting, APU	3.4.			Tropical Climate, Operation In,	2.9.		
Piston Rings	6.24.	F6-21		Troubleshooting Procedures,	5.5.		
Pistons	6.22.	F6-19		Direct Support			
PMCS Table, Operator			T2-2	Troubleshooting Procedures,	3.3.		
PMCS Table, Unit			T4-2	Operator			
PMCS, Introduction to Operator	2.2.			Troubleshooting Procedures, Unit	4.11.		
PMCS, Introduction to Unit	4.7.			Turbocharger, Engine	4.44	F4-32	
Preoperational Checks	2.4.						
Preparation for Storage of Shipment	4.12.						
Push Rods	6.4.	F6-1					
	R			U			
Radiator	3.8.,	F3-4	T3-2	Unit Troubleshooting Procedures	4.11.		
	4.19.			Unit Preventive Maintenance Checks			T4-2
Radiator Cap	3.7.,	F3-3		And Services (PMCS)			
	5.11.	F5-5		APU Lubrication Instructions	4.9.		
Radiator Coolant Drain Valve	4.20.	F4-7		Introductions to Unit PMCS Table	4.7.		
Radiator Overflow tank	4.28.	F4-15		Warnings, Cautions, and Notes	4.8.		
Radiator Hoses	4.24.	F4-11		Unusual Conditions, Operation Under			
Radiator Seal Fairing	6.32.	F6-29		Nuclear, Biological, and Chemical			
Regulator Box	5.23.	F5-17		(NBC) Decontamination Procedures	2.11.		
Relay Board	5.18.	F5-12		Operation in Artic Climate	2.7.		
Relay Sockets	5.21.	F5-15		Operation in Desert Climate	2.8.		
Relief Valve	5.10.	F5-4		Operation in Salt Air or Sea Spray	2.10.		
Repair Parts	4.4.			Operation in Tropical Climate	2.9.		
Repair Parts (DS)	5.3.			Usual Conditions, Operation Under,			
Repair Parts (GS)	6.3.			Assembly and Preparation for Use	2.3.		
Repair, Wiring Harness	5.25.			Preoperational Checks	2.4.		
Reporting Equipment Improvement				Operating Procedures	2.5.		
Recommendations	1.6.			Shut-Down	2.6.		
Rocker Arm Assembly	5.36.	F5-28					
Rotor	6.37.	F6-34		V			
Routing Diagram, Operator PMCS		F2-2		Valve Spring	6.9.	F6-6	
				Valve Seat	6.10.	F6-7	
				Valve Guide	6.8.	F6-5	
				Valve Clearance	6.10.	F6-7	
				Valves	6.7.	F6-4	
	S			Vibration Isolator Mount Assembly			
Safety Relays, Electromagnetic	5.20.	F5-14		(MEP-903B and MEP-903C), Frame			
Salt Air or Sea Spray, Operation in	2.10.			Assembly (Models MEP-903A,			
Service Upon Receipt				MEP-903B, and MEP-903C) and	5.32.	F5-24	
Inspection	4.5.						
Service	4.6.			W			
Shroud Housing, Fan Guard,	4.18.	F4-5		Warranty Information	1.7.		
Fan Shroud				Water Flange	6.33.	F6-30	
Shut-Down (Oper Under Usual Cond)	2.6.			Water Temperature Gauge	5.30.	F5-22	
Special Instructions				Water Pump	5.12.	F5-6	
For Administrative Storage	4.13.			Wiring Diagram, APU		FO-1	
Special Tools, TMDE, and Support				Wire Harness,			
Equipment (Unit Maintenance)	4.3.			APU DC Box, J3	5.26.	F5-19	T5-1
Special Tools, TMDE, and Support						FO-3	
Equipment (DS)	5.2.			Wiring Harness Control Cable	5.29		T5-4
Special Tools, TMDE, and Support				Description	1.13.8.		
Equipment (CoS)	6.2.			Wiring Harness,			
Speed Sensor	4.56.	F4-44		Engine P1	5.27.	F5-20,	T5-2
Speed Control Plate	6.11.	F6-8				FO-2	
Starter	4.37.	F4-25		Wiring Harness J1	5.28.	F5-21,	T5-3
START-PREHEAT Toggle Switch	4.62.	F4-50				FO-4	
Start-Up (Operation Under Usual				Wiring Harness J2	5.31.	F5-23,	T5-5
Conditions)	2.5.					FO-5	
Storage or Shipment, Preparation for	4.12.			Wiring Harness Repair	5.25.		
	T						
Tappets	6.6.	F6-3					
Temperature Sender	4.25.	F4-12					
Temperature Switch	4.26.	F4-13					
Thermostat	4.22.	F4-9					

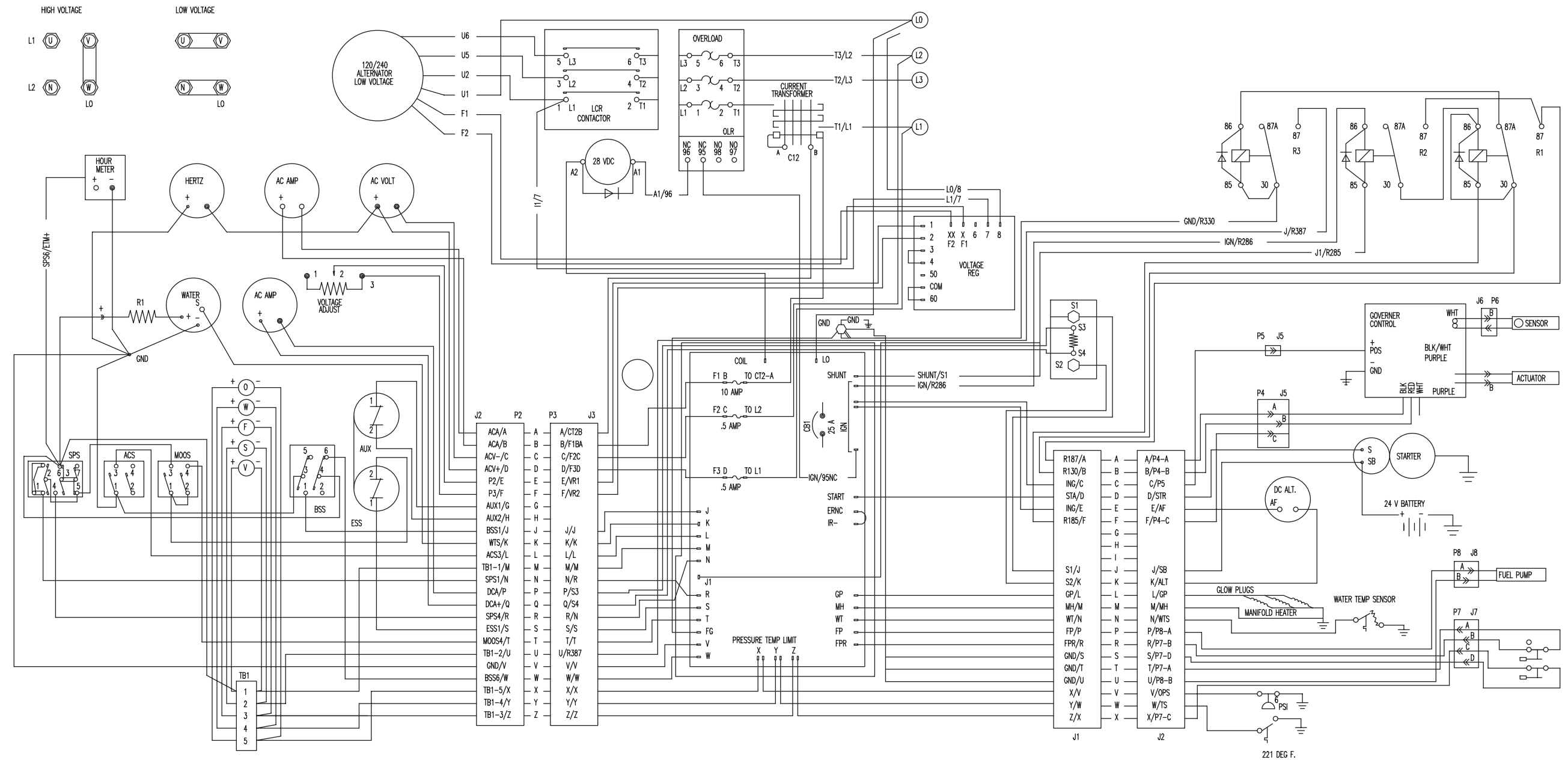

Figure FO-1. APU Wiring Diagram (SICPS and WIN-T)

WIRE REF. NO.	TERMINATION		WIRE FIND NO.
	FROM	TO	
1	P1-A	P4-A	16
2	P1-B	P4-B	16
3	P1-C	P5	16
4	P1-D	STR	16
5	P1-E	AF	16
6	P1-F	P4-C	16
7	P1-J	SB	17
8	P1-K	ALT	17
9	P1-L	GP	17
10	P1-M	MH	17
11	P1-N	WTS	16
12	P1-P	P8-A	16
13	P1-R	P7-B	16
14	P1-S	P7-D	16
15	P1-T	P7-A	16
16	P1-U	P8-B	16
17	P1-V	OPS	16
18	P1-W	TS	16
19	P1-X	P7-C	16

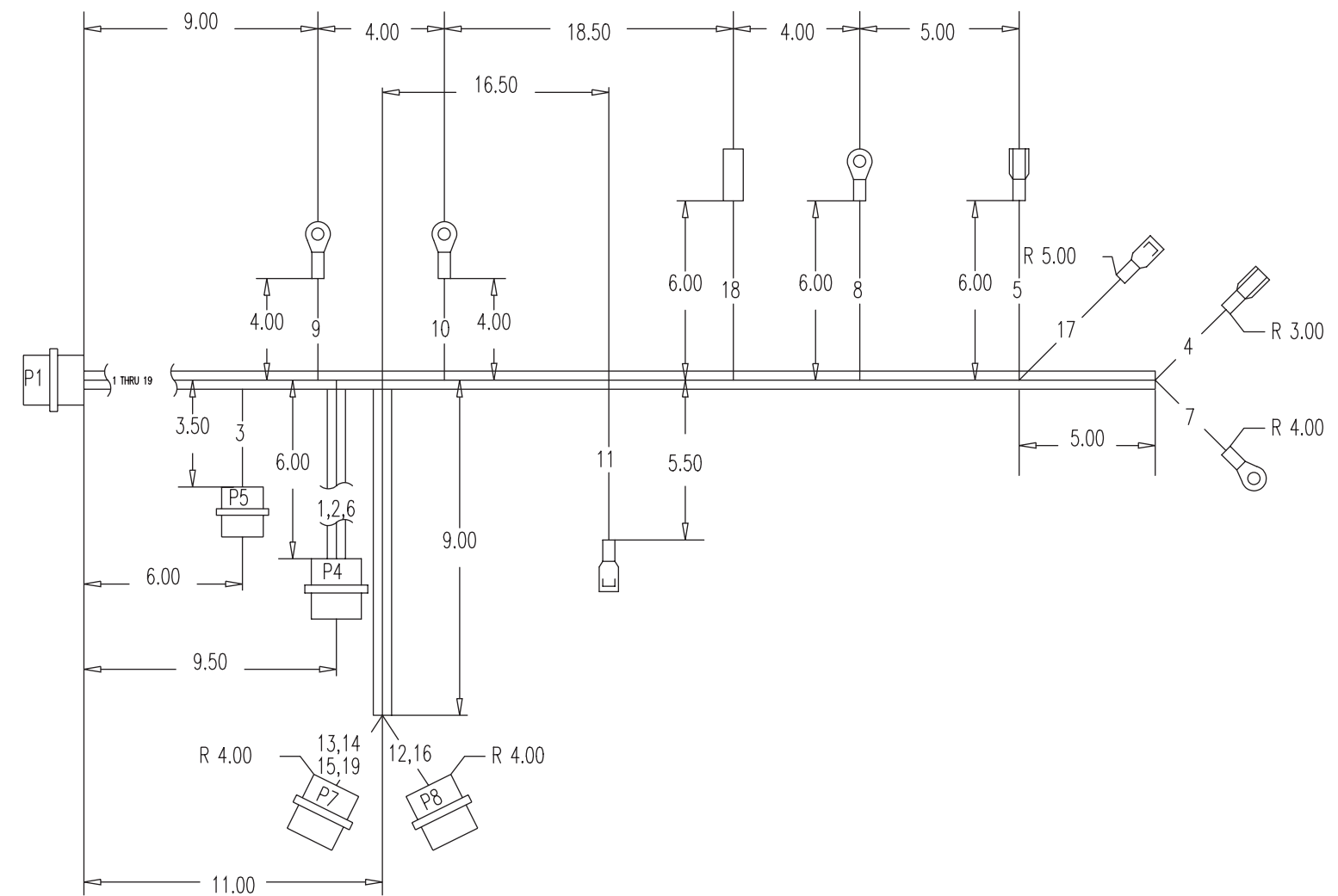

Figure FO-2. Wiring Harness, Engine P1
Wiring Diagram

WIRE REF. NO.	TERMINATION	
	FROM	TO
1	J3-A	CT2B
2	J3-B	F1BA
3	J3-C	F2C
4	J3-D	F3D
5	J3-E	VR1
6	J3-F	VR2
7	J3-J	J
8	J3-K	K
9	J3-L	L
10	J3-M	M
11	J3-N	R
12	J3-P	S3
13	J3-Q	S4
14	J3-R	N
15	J3-S	S
16	J3-T	T
17	J3-U	R387
18	J3-V	V
19	J3-W	W
20	J3-X	X
21	J3-Y	Y
22	J3-Z	Z

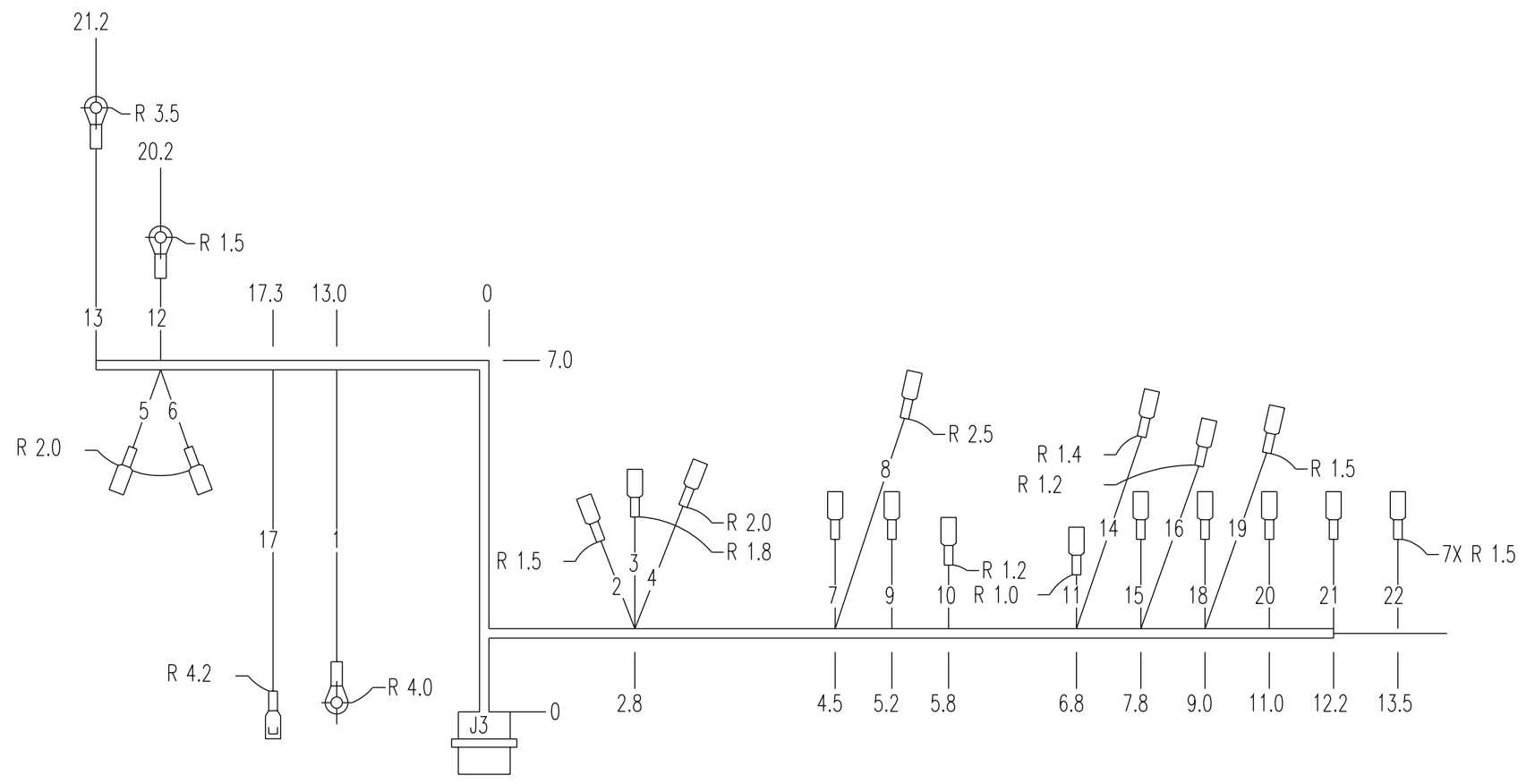

Figure FO-3. Wiring Harness, APU DC Box J3
Wiring Diagram

WIRE REF. NO.	TERMINATION	TERMINATION	WIRE FIND NO.
	FROM	TO	
1	J1-A	R187	9
2	R287	R187	11
3	J1-B	R130	9
4	R186	R130	11
5	R186	R230	11
6	J1-C	IGN	9
7	J1-D	STA	9
8	J1-E	IGN	9
9	J1-F	R185	9
10	J1-J	S1	10
11	J1-K	S2	10
12	J1-L	GP	10
13	J1-M	MH	10
14	J1-N	WT	9
15	J1-P	FP	9
16	J1-R	FPR	9
17	J1-S	GND	9
18	J1-T	GND	9
19	J1-U	GND	9
20	J1-V	X	9
21	J1-W	Y	9
22	J1-X	Z	9

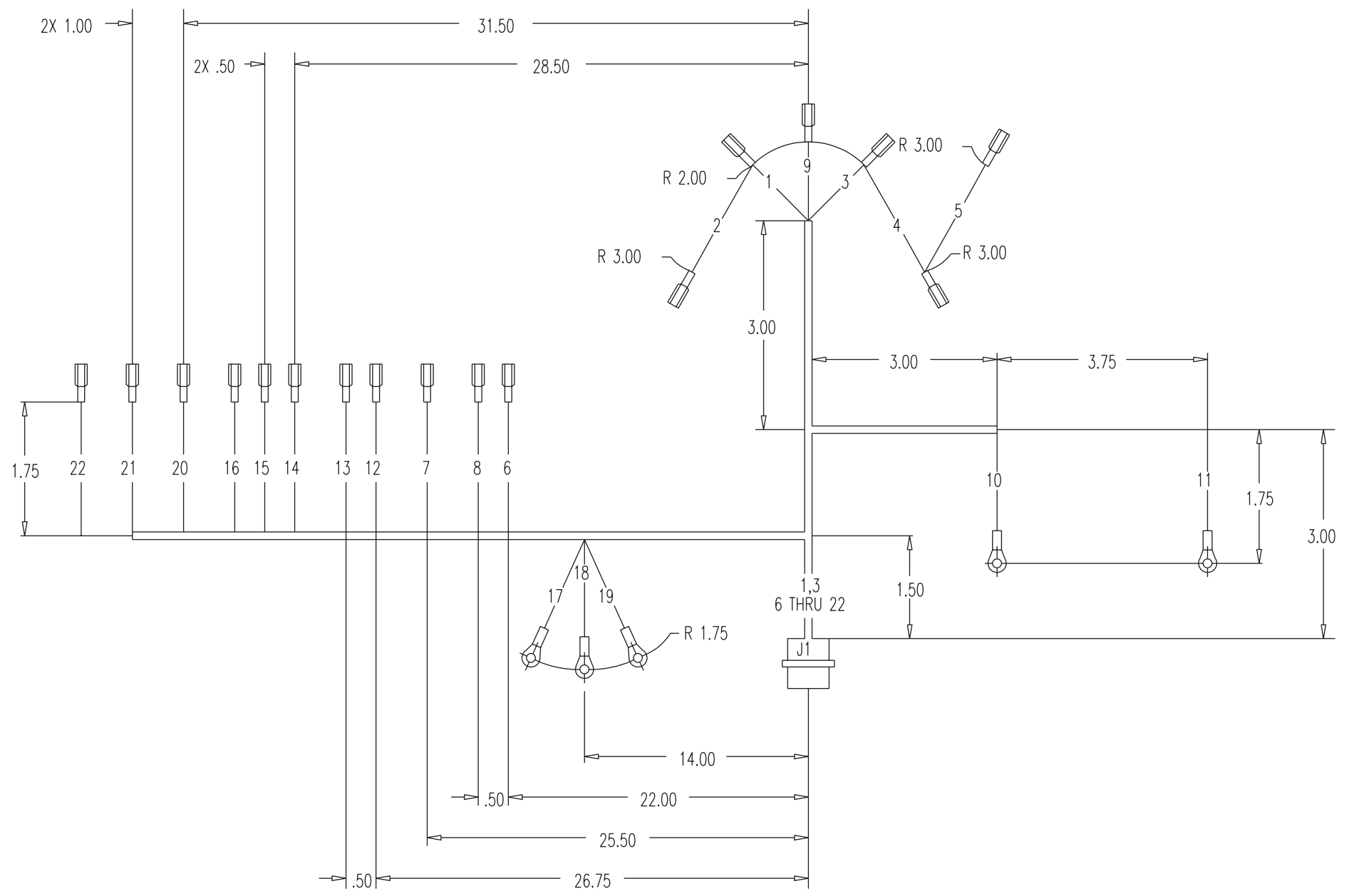

Figure FO-4. Wiring Harness, J1 Wiring Diagram

WIRE REF. NO.	TERMINATION	TERMINATION	WIRE FIND NO.
	FROM	TO	
1	J2-A	ACA	6
2	J2-B	ACA+	6
3	J2-C	ACV	6
4	J2-D	ACV+	6
5	J2-E	P2	6
6	J2-F	P3	6
7	J2-G	AUX1	6
8	J2-H	AUX2	6
9	J2-J	BSS1	6
10	J2-K	WTRS	6
11	J2-L	ACS3	6
12	J2-M	TB1-1	6
13	J2-N	SPS1	6
14	J2-P	DCA	6
15	J2-Q	DCA+	6
16	J2-R	SPS4	6
17	J2-S	ESS1	6
18	J2-T	MOOS4	6
19	J2-U	TB1-2	6
20	J2-V	GND	6
21	J2-W	BSS6	6
22	J2-X	TB1-5	6
23	J2-Y	TB1-4	6
24	J2-Z	TB1-3	6

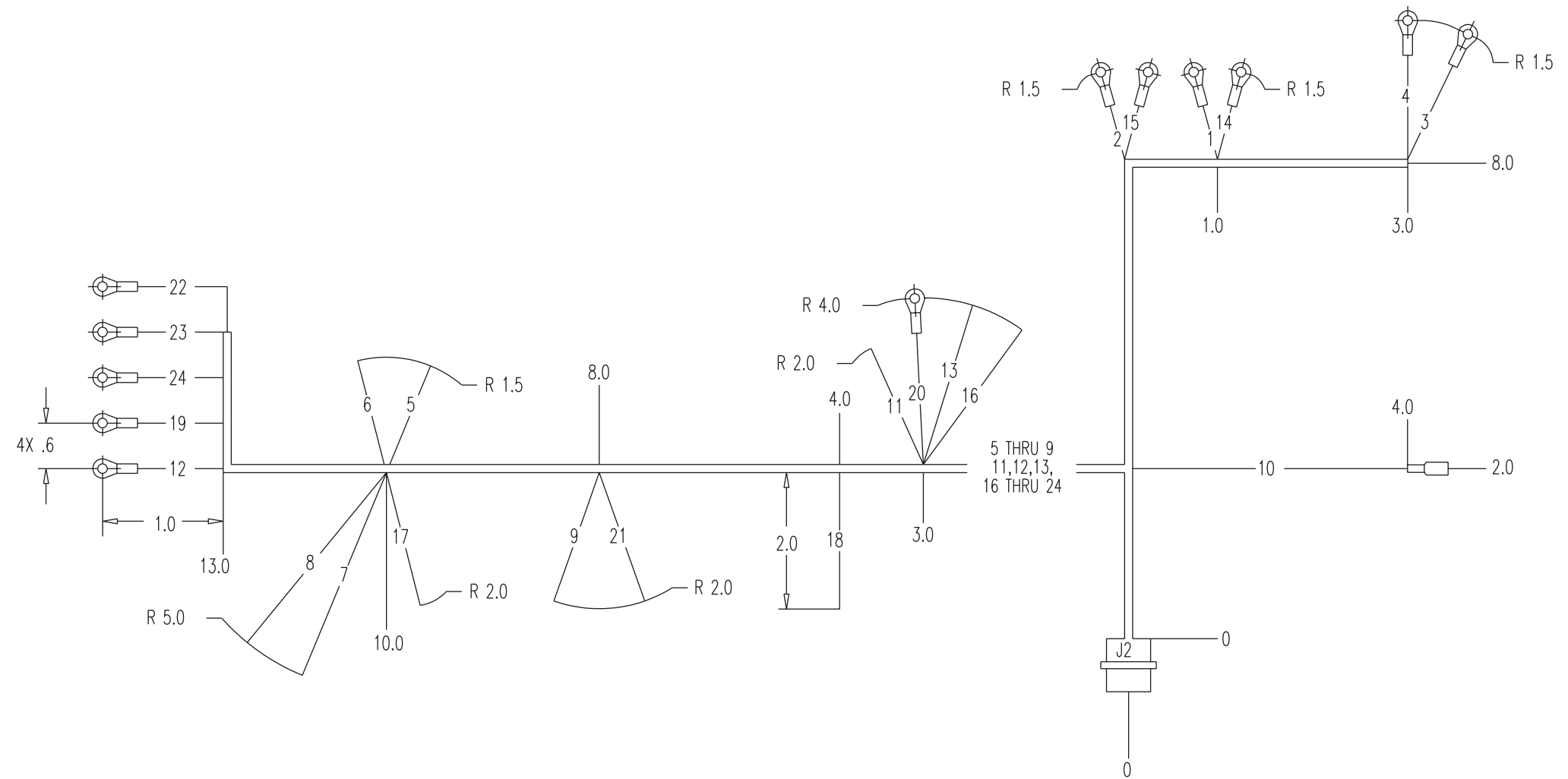

Figure FO-5. Wiring Harness, J2, APU Control Box, Wiring Diagram

WIRE REF. NO.	WIRE COLOR CODE	TERMINATION	
		FROM	TO
1	BLACK	P2-A	P3-A
2	WHITE	P2-B	P3-B
3	RED	P2-C	P3-C
4	GREEN	P2-D	P3-D
5	ORANGE	P2-E	P3-E
6	BLUE	P2-F	P3-F
7	WHITE/BLACK	P2-G	P3-G
8	RED/BLACK	P2-H	P3-H
9	GREEN/BLACK	P2-J	P3-J
10	ORANGE/BLACK	P2-K	P3-K
11	BLUE/BLACK	P2-L	P3-L
12	BLACK/WHITE	P2-M	P3-M
13	RED/WHITE	P2-N	P3-N
14	GREEN/WHITE	P2-P	P3-P
15	BLUE/WHITE	P2-Q	P3-Q
16	BLACK/RED	P2-R	P3-R
17	WHITE/RED	P2-S	P3-S
18	ORANGE/RED	P2-T	P3-T
19	BLUE/RED	P2-U	P3-U
20	RED/GREEN	P2-V	P3-V
21	ORANGE/GREEN	P2-W	P3-W
22	BLACK/WHITE/RED	P2-X	P3-X
23	WHITE/BLACK/RED	P2-Y	P3-Y
24	RED/BLACK/WHITE	P2-Z	P3-Z
25	GREEN/BLACK/WHITE	-	-

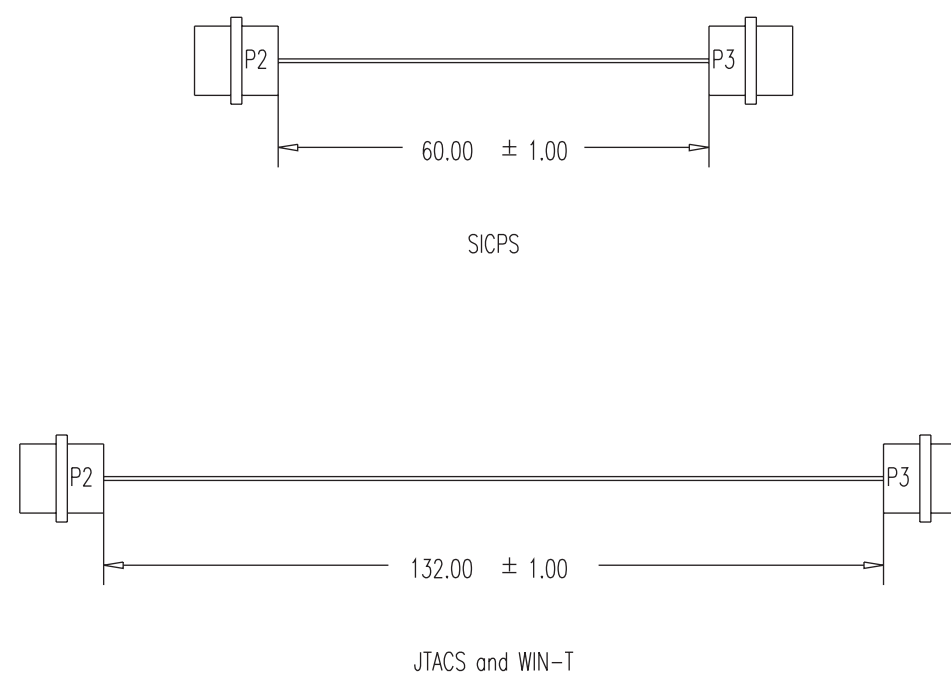

Figure FO-6. Wiring Harness, Control Cable Wiring Diagram

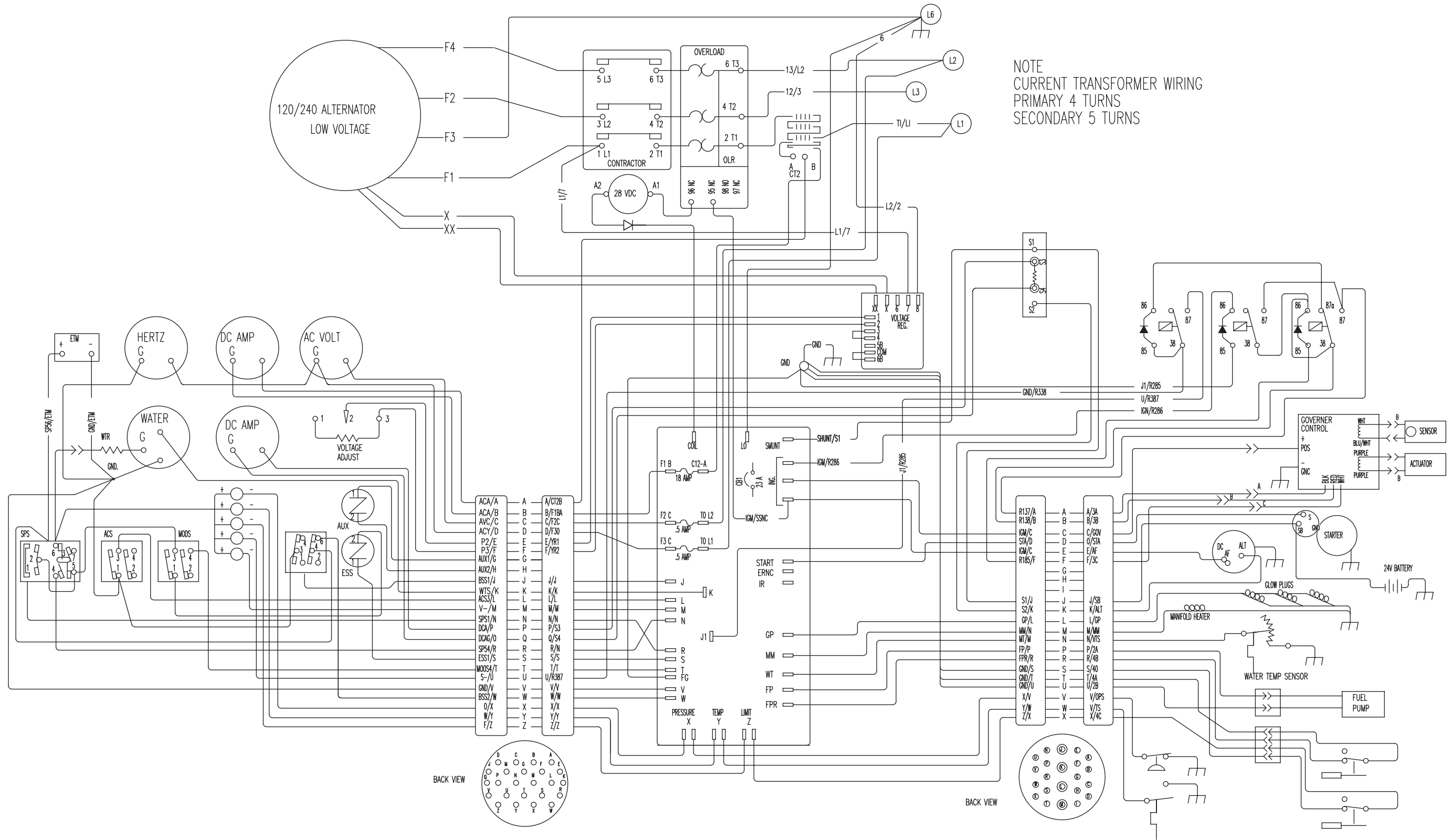

Figure FO-7. APU Wiring Diagram (JTACS)



THEN ... JOT DOWN THE INFO ABOUT IT ON THIS FORM. CAREFULLY TEAR IT OUT. FOLD IT AND DROP IT IN THE MAIL.

SOMETHING WRONG WITH THIS PUBLICATION

FROM: (PRINT YOUR UNIT'S COMPLETE ADDRESS)
 Commander
 Stateside Army Depot
 ATTN: AMSTA-US
 Stateside, N.J. 07703-5007

DATE SENT
 10 July 1975

PUBLICATION NUMBER TM 11-5840-340-20P	PUBLICATION DATE 23 Jan 74	PUBLICATION TITLE Radar Set AN/PRC-76
--	-------------------------------	--

BE EXACT PIN-POINT WHERE IT IS				IN THIS SPACE TELL WHAT IS WRONG AND WHAT SHOULD BE DONE ABOUT IT:
PAGE NO	PARA GRAPH	FIGURE NO	TABLE NO	
2-25	2-28			<p>Recommend that the installation antenna alignment procedure be changed throughout to specify a 20 IFF antenna lag rather than 10.</p> <p>REASON: Experience has shown that with only a 10 lag, the antenna servo system is too sensitive to wind gusting in excess of 25 knots, and has a tendency to rapidly accelerate and decelerate as it hunts, causing strain to the drive train. Hunting is minimized by adjusting the lag to 20 without degradation of operation.</p>
3-10	3-3		3-1	<p>Item 5, Functional column. Change • 2 dB" to • 3 dB".</p> <p>REASON: The adjustment procedure for the TRANS POWER FAULT indicator calls for a 3 dB (500 watts) adjustment to light the TRANS POWER FAULT indicator.</p>
5-6	5-8			<p>Add new step f.1 to read, • Replace cover plate removed in step f.1, above."</p> <p>REASON: To replace the cover plate.</p>
		FO-3		<p>Zone C 3. On J1-2, change • +24 VDC" to • +5 VDC".</p> <p>REASON: This is the output line of the 5 VDC power supply. +24 VDC is the input voltage.</p>

TEAR ALONG DOTTED LINE

PRINTED NAME, GRADE OR TITLE AND TELEPHONE NUMBER SSG I. M. DeSpirito 999-1776	SIGN HERE
---	---------------

FILL IN YOUR
UNIT'S ADDRESS

FOLD BACK

DEPARTMENT OF THE ARMY

OFFICIAL BUSINESS

PLEASE
AFFIX
STAMP
POSTAGE
REQUIRED

SAMPLE

Commander
U.S. Army Communications-Electronics Command
and Fort Monmouth
ATTN: AMSEL-LC-LEO-D-CS-CFO
Fort Monmouth, New Jersey 07703-5006

TEAR ALONG DOTTED LINE

SOMETHING WRONG WITH THIS PUBLICATION



THEN ... JOT DOWN THE INFO ABOUT IT ON THIS FORM. CAREFULLY TEAR IT OUT. FOLD IT AND DROP IT IN THE MAIL.

FROM: (PRINT YOUR UNIT'S COMPLETE ADDRESS)

DATE SENT

PUBLICATION NUMBER

PUBLICATION DATE

PUBLICATION TITLE

BE EXACT PIN-POINT WHERE IT IS

IN THIS SPACE TELL WHAT IS WRONG AND WHAT SHOULD BE DONE ABOUT IT:

PAGE NO

PARA GRAPH

FIGURE NO

TABLE NO

TEAR ALONG DOTTED LINE

PRINTED NAME, GRADE OR TITLE AND TELEPHONE NUMBER

SIGN HERE

FILL IN YOUR
UNIT'S ADDRESS

FOLD BACK

DEPARTMENT OF THE ARMY

OFFICIAL BUSINESS

PLEASE
AFFIX
STAMP
POSTAGE
REQUIRED

TEAR ALONG DOTTED LINE

Commander
U.S. Army Communications-Electronics Command
and Fort Monmouth
ATTN: AMSEL-LC-LEO-D-CS-CFO
Fort Monmouth, New Jersey 07703-5006

SOMETHING WRONG WITH THIS PUBLICATION



THEN ... JOT DOWN THE INFO ABOUT IT ON THIS FORM. CAREFULLY TEAR IT OUT. FOLD IT AND DROP IT IN THE MAIL.

FROM: (PRINT YOUR UNIT'S COMPLETE ADDRESS)

DATE SENT

PUBLICATION NUMBER

PUBLICATION DATE

PUBLICATION TITLE

BE EXACT PIN-POINT WHERE IT IS

IN THIS SPACE TELL WHAT IS WRONG AND WHAT SHOULD BE DONE ABOUT IT:

PAGE NO

PARA GRAPH

FIGURE NO

TABLE NO

TEAR ALONG DOTTED LINE

PRINTED NAME, GRADE OR TITLE AND TELEPHONE NUMBER

SIGN HERE

FILL IN YOUR
UNIT'S ADDRESS

FOLD BACK

DEPARTMENT OF THE ARMY



OFFICIAL BUSINESS

PLEASE
AFFIX
STAMP
POSTAGE
REQUIRED

Commander
U.S. Army Communications-Electronics Command
and Fort Monmouth
ATTN: AMSEL-LC-LEO-D-CS-CFO
Fort Monmouth, New Jersey 07703-5006

TEAR ALONG DOTTED LINE

SOMETHING WRONG WITH THIS PUBLICATION

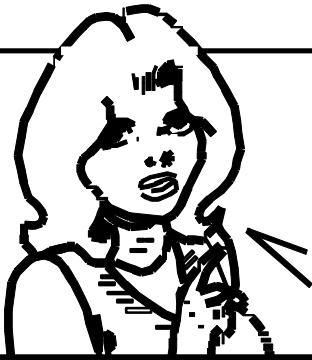

THEN ... JOT DOWN THE INFO ABOUT IT ON THIS FORM. CAREFULLY TEAR IT OUT. FOLD IT AND DROP IT IN THE MAIL.

FROM: (PRINT YOUR UNIT'S COMPLETE ADDRESS)

DATE SENT

PUBLICATION NUMBER

PUBLICATION DATE

PUBLICATION TITLE

BE EXACT PIN-POINT WHERE IT IS

IN THIS SPACE TELL WHAT IS WRONG AND WHAT SHOULD BE DONE ABOUT IT:

PAGE NO

PARA GRAPH

FIGURE NO

TABLE NO

TEAR ALONG DOTTED LINE

PRINTED NAME, GRADE OR TITLE AND TELEPHONE NUMBER

SIGN HERE

FILL IN YOUR
UNIT'S ADDRESS

FOLD BACK

DEPARTMENT OF THE ARMY



OFFICIAL BUSINESS

PLEASE
AFFIX
STAMP
POSTAGE
REQUIRED

Commander
U.S. Army Communications-Electronics Command
and Fort Monmouth
ATTN: AMSEL-LC-LEO-D-CS-CFO
Fort Monmouth, New Jersey 07703-5006

TEAR ALONG DOTTED LINE

By Order of the Secretary of the Army:

Official:

JOEL B. HUDSON
*Administrative Assistant to the
Secretary of the Army*
0224010

ERIC K. SHINSEKI
*General, United States Army
Chief of Staff*

DISTRIBUTION:

To be distributed in accordance with the initial distribution number (IDN) 256751 requirements for TM 9-6115-670-14&P.

The Metric System And Equivalent

Linear Measure

1 centimeter = 10 millimeters = .39 inch
 1 decimeter = 10 centimeters = 3.94 inches
 1 meter = 10 decimeters = 39.37 inches
 1 decameter = 10 meters = 32.8 feet
 1 hectometer = 10 decameters = 328.08 feet
 1 kilometer = 10 hectometers = 3,208.8 feet

Weights

1 centigram = 10 milligrams = .15 grain
 1 decigram = 10 centigrams = 1.54 grains
 1 gram = 10 decigrams = .035 ounce
 1 decagram = 10 grams = .35 ounce
 1 hectogram = 10 decagrams = 3.52 ounces
 1 kilogram = 10 hectograms = 2.2 pounds
 1 quintal = 100 kilograms = 220.46 pounds
 1 metric ton = 10 quintals = 1.1 short tons

Liquid Measure

1 centiliter = 10 milliliters = .34 fl. ounce
 1 deciliter = 10 centiliters = 3.38 fl. ounces
 1 liter = 10 deciliters = 33.8 fl. ounces
 1 decaliter = 10 liters = 2.64 gallons
 1 hectoliter = 10 decaliters = 26.42 gallons
 1 kiloliter = 10 hectoliters = 264.18 gallons

Square Measure

1 sq. centimeter = 100 sq. millimeters = .155 sq. inches
 1 sq. decimeter = 100 sq. centimeters = 15.5 sq. inches
 1 sq. meter (centare) = 100 sq. decimeters = 10.76 sq. feet
 1 sq. decameter (are) = 100 sq. meters = 1,076.4 sq. feet
 1 sq. hectometer (hectare) = 100 sq. decameters = 2.47 acres
 1 sq. kilometer = 100 sq. hectometers = .386 sq. mile

Cubic Measure

1 cu. centimeter = 1000 cu. millimeters = .06 cu. inch
 1 cu. decimeter = 1000 cu. centimeters = 61.02 cu. inches
 1 cu. meter = 1000 cu. decimeters = 35.31 cu. feet

Approximate Conversion Factors

To Change	To	Multiply by	To Change	To	Multiply by
inches	centimeters	2.540	ounce-inches	newton-meters	.007062
feet	meters	.305	centimeters	inches	.394
yards	meters	.914	meters	feet	3.280
miles	kilometers	1.609	meters	yards	1.094
square inches	square centimeters	6.451	kilometers	miles	.621
square feet	square meters	.093	square centimeters	square inches	.155
square yards	square meters	.836	square meters	square feet	10.764
square miles	square kilometers	2.590	square meters	square yards	1.196
acres	square hectometers	.405	square kilometers	square miles	.386
cubic feet	cubic meters	.028	square hectometers	acres	2.471
cubic yards	cubic meters	.765	cubic meters	cubic feet	35.315
fluid ounces	milliliters	29.573	cubic meters	cubic yards	1.308
pints	liters	.473	millimeters	fluid ounces	.034
quarts	liters	.946	liters	pints	2.113
gallons	liters	3.785	liters	quarts	1.057
ounces	grams	28.349	liters	gallons	.264
pounds	kilograms	.454	grams	ounces	.035
short tons	metric tons	.907	kilograms	pounds	2.205
pound-feet	newton-meters	1.356	metric tons	short tons	1.102
pound-inches	newton-meters	.11296			

Temperature (Exact)

°F	Fahrenheit temperature	5/9 (after subtracting 32)	Celsius temperature	°C
----	---------------------------	-------------------------------	------------------------	----

